



HAL
open science

Global molecular analysis and APOE mutations in a cohort of autosomal dominant hypercholesterolemia patients in France

René Wintjens, Dominique Bozon, Khaldia Belabbas, Félicien Mbou, Jean-Philippe Girardet, Patrick Tounian, Mathilde Jolly, Franck Boccard, Ariel Cohen, Alexandra Karsenty, et al.

► To cite this version:

René Wintjens, Dominique Bozon, Khaldia Belabbas, Félicien Mbou, Jean-Philippe Girardet, et al. Global molecular analysis and APOE mutations in a cohort of autosomal dominant hypercholesterolemia patients in France. *Journal of Lipid Research*, 2016, 57 (3), pp.482-491. 10.1194/jlr.P055699 . hal-01662494

HAL Id: hal-01662494

<https://hal.univ-lorraine.fr/hal-01662494v1>

Submitted on 13 Dec 2017

HAL is a multi-disciplinary open access archive for the deposit and dissemination of scientific research documents, whether they are published or not. The documents may come from teaching and research institutions in France or abroad, or from public or private research centers.

L'archive ouverte pluridisciplinaire **HAL**, est destinée au dépôt et à la diffusion de documents scientifiques de niveau recherche, publiés ou non, émanant des établissements d'enseignement et de recherche français ou étrangers, des laboratoires publics ou privés.



Distributed under a Creative Commons Attribution 4.0 International License

Global molecular analysis and APOE mutations in a cohort of autosomal dominant hypercholesterolemia patients in France^S

René Wintjens,* Dominique Bozon,[†] Khaldia Belabbas,[§] Félicien MBou,[†] Jean-Philippe Girardet,[†] Patrick Tounian,[†] Mathilde Jolly,[#] Franck Boccara,[§] Ariel Cohen,[§] Alexandra Karsenty,[†] Béatrice Dubern,[†] Jean-Claude Carel,^{***††} Ahlam Azar-Kolakez,^{***††} François Feillet,^{§§,††} François Labarthe,^{||} Anne-Marie Colin Gorsky,^{##} Alice Horovitz,^{§§} Catherine Tamarindi,^{***} Pierre Kieffer,^{†††} Anne Lienhardt,^{§§§} Olivier Lascols,[§] Mathilde Di Filippo,^{†,†††} and Fabienne Dufernez^{1,§}

Faculty of Pharmacy (CP206/04), * Université Libre de Bruxelles, B-1050 Brussels, Belgium; Centre de Biologie et de Pathologie Est,[†] CHU Lyon, France; Laboratoire Commun de Biologie et Génétiques Moléculaires (LCBGM),[§] AP-HP (Assistance Publique-Hopitaux de Paris), Hôpital Saint-Antoine, F-75012, Paris, France; Service d'Endocrinologie,[†] CHU du Lamentin, F-97232 Le Lamentin, Martinique, France; Service de Gastroentérologie et Nutrition Pédiatrique,[†] AP-HP, Hôpital Trousseau, F-75012, Paris, France; Service d'Endocrinologie, Diabétologie et Nutrition,[#] CH Angers, F-49933, Angers, France; Service de Cardiologie,[§] AP-HP, Hôpital Saint-Antoine, F-75012, Paris, France; Université Paris Diderot, ** Sorbonne Paris Cité, F-75019, Paris, France; Service d'Endocrinologie Diabétologie Pédiatrique et Centre de Référence des Maladies Endocriniennes Rares de la Croissance,^{††} AP-HP, Hôpital Robert Debré, F-75019, Paris, France; Service de Médecine Infantile et de génétique clinique,^{§§} CHU Nancy-Brabois, F-54511 Vandoeuvre les Nancy, France; INSERM NGERE UMR 954,^{††} F-54500, Vandoeuvre les Nancy, France; Service de médecine pédiatrique,^{||} Hopital Clocheville, CHU Tours, F-37044, Tours, France; Service de pédiatrie générale,^{##} Centre Hospitalier d'Argenteuil, F-95107, Argenteuil, France; Service de Cardiologie,^{§§} CHU Bordeaux-Haut Lévêque, F-33604, Pessac, France; Service de Maternité,^{***} CH Hagueneau, F-67504 Hagueneau, France; Service de Médecine Interne,^{†††} CH Mulhouse, Hôpital E. Muller, F-68070 Mulhouse, France; Service de Pédiatrie Médicale,^{§§§} CH Limoges, Hôpital mère/enfants, F-87042 Limoges, France; and Université de Lyon,^{†††} INSERM U1060, INSA de Lyon, INRA U1235, Université Lyon-1, Oullins F-69600, France

Abstract Autosomal dominant hypercholesterolemia (ADH) is a human disorder characterized phenotypically by isolated high-cholesterol levels. Mutations in the low density lipoprotein receptor (*LDLR*), *APOB*, and proprotein convertase subtilisin/kexin type 9 (*PCSK9*) genes are well known to be associated with the disease. To characterize the genetic background associated with ADH in France, the three ADH-associated genes were sequenced in a cohort of 120 children and 109 adult patients. Fifty-one percent of the cohort had a possible deleterious variant in *LDLR*, 3.1% in *APOB*, and 1.7% in *PCSK9*. We identified 18 new variants in *LDLR* and 2 in *PCSK9*. Three *LDLR* variants, including two newly identified, were studied by minigene reporter assay confirming the predicted effects on splicing. Additionally, as recently an in-frame deletion in the *APOE* gene was found to be linked to ADH, the sequencing of this latter gene was performed in patients without a deleterious variant in the three former genes. An *APOE* variant was identified in three patients with isolated severe hypercholesterolemia giving a

frequency of 1.3% in the cohort. Therefore, even though *LDLR* mutations are the major cause of ADH with a large mutation spectrum, *APOE* variants were found to be significantly associated with the disease.^{§§} Furthermore, using structural analysis and modeling, the identified *APOE* sequence changes were predicted to impact protein function.—Wintjens, R., D. Bozon, K. Belabbas, F. MBou, J.-P. Girardet, P. Tounian, M. Jolly, F. Boccara, A. Cohen, A. Karsenty, B. Dubern, J.-C. Carel, A. Azar-Kolakez, F. Feillet, F. Labarthe, A.-M. C. Gorsky, A. Horovitz, C. Tamarindi, P. Kieffer, A. Lienhardt, O. Lascols, M. Di Filippo, and F. Dufernez. **Global molecular analysis and APOE mutations in a cohort of autosomal dominant hypercholesterolemia patients in France.** *J. Lipid Res.* 2016. 57: 482–491.

Abbreviations: ADH, autosomal dominant hypercholesterolemia; FD, dominant familial dysbetalipoproteinemia; FH, familial hypercholesterolemia; HSF, Human Splicing Finder; LDL-C, low density lipoprotein-cholesterol; *LDLR*, low density lipoprotein receptor; LOVD, Leiden Open Variation Database; MES, MaxEntScan; MLPA, multiplex ligation-dependent probe amplification; NNSP, Neural Network Splice Prediction; *PCSK9*, proprotein convertase subtilisin/kexin type 9; SSFL, Splice Site Finder Like; TC, total cholesterol; VUS, variant of unknown clinical significance.

¹To whom correspondence should be addressed.

e-mail: fabienne.dufernez@sat.aphp.fr

^SThe online version of this article (available at <http://www.jlr.org>) contains a supplement.

This work was supported by the Biology-Imaging District of East-Hospitals Group of AP-HP (Assistance Publique-Hôpitaux de Paris). R. Wintjens is Research Associate at the National Fund for Scientific Research FNRS-FRS (Belgium).

Manuscript received 21 October 2014 and in revised form 15 January 2016.

Published, JLR Papers in Press, January 22, 2016

DOI 10.1194/jlr.P055699

Supplementary key words familial hypercholesterolemia • apolipoproteins • apolipoprotein E • cholesterol • low density lipoprotein • phenotype/genotype correlation

The clinical phenotype of autosomal dominant hypercholesterolemia (ADH) is characterized by an increase of plasma low density lipoprotein-cholesterol (LDL-C) levels, enhanced tendon xanthomas, and a premature risk of CVD. ADH is a frequent, inherited human disorder with a heterozygous prevalence of 1 in 500, albeit for a few European populations this prevalence has been reported to be 1 in 200 (1). This disease usually results from mutations in genes of the low density lipoprotein receptor (*LDLR*), apoB-100 (*APOB*), and proprotein convertase subtilisin/kexin type 9 (*PCSK9*) (2, 3). An in-frame deletion in apoE gene (*APOE*) has been described in two unrelated European families affected with ADH (4, 5), thereby adding a fourth gene associated with the disease. Mutations in *APOE* have been found previously in dominant familial dysbetalipoproteinemia (FD) and familial combined hyperlipidemia (FCHL), both diseases being characterized by a high risk of CVD and by markedly elevated cholesterol and TG levels (6, 7).

The severity of the phenotype in ADH varies genetically with the type of mutation and the gene affected (8, 9). *LDLR* is the gene most frequently associated with ADH and is also the best characterized. It is responsible for the disease called familial hypercholesterolemia (FH) (9–11). With the exception of a few founder populations, the spectrum of *LDLR* causing FH mutations is large. To date, more than 1,600 variants have been identified [Leiden Open Variation Database (LOVD) of ADH, <http://www.ucl.ac.uk/ldlr/>; and Human Gene Mutation Database, <http://www.hgmd.cf.ac.uk/ac/>]. France is among the most heterogeneous in the world: recent studies have identified almost 400 mutations in more than 1,000 affected subjects (9, 12).

In contrast, only a few mutations implicated in ADH were identified in the *APOB* gene, causing the familial defective apoB-100 (13, 14). Eight pathogenic *APOB* variants were localized within or adjacent to the *LDLR* binding domain, with the p.Arg3527Gln being the most common variant in Europe (15–17). Very recently, three novel probable disease-causing alterations found outside the LDL binding domain were reported (18, 19). It is interesting to note that the apoB-defective patients are usually less affected with hypercholesterolemia, having plasma cholesterol levels lower than those encountered in FH patients (9, 13).

The *PCSK9* gene, the third gene known to be associated with ADH, encodes a protein that has been shown to degrade the *LDLR*. ADH due to “gain of function” *PCSK9* mutations is uncommon, occurring in less than 1% of cases (9–11). Note that *PCSK9* inhibitors are a promising new class of drugs for LDL-C reduction (20, 21).

In the lipid-free state, the apoE protein exhibits two distinct structural domains: an N-terminal domain (residues 1–191), which includes the *LDLR* binding region, and a C-terminal domain (residues 216–299), which contains the major lipid binding region (22). The apoE is polymorphic

with three major isoforms that differ in cysteine and arginine content at positions 130 and 176 (note that without the peptide signal, these positions are 112 and 158, respectively). The E3 isoform, with Cys130 and Arg176, is the most common form and hence is identified as the wild type. The E4 isoform (Arg130/Arg176) is present in almost 15% of the population and has been associated with hypercholesterolemia and with an increased CVD risk (23, 24). The E2 isoform (Cys130/Cys176) affects almost 6% of the population and is associated with low cholesterol and hypertriglyceridemia in heterozygotes and type III hyperlipoproteinemia in homozygotes (23, 24).

As FH responds well to drug treatment, early diagnosis is beneficial for the reduction of atherosclerosis and CVD risks. Diagnostic tools have been developed using different criteria (25–28). Here, a cohort of 229 ADH French patients, from an unpublished population and from unrelated families, was analyzed with global genetic testing, including *LDLR*, a fragment of exon 26 of *APOB*, *PCSK9*, and *APOE* analysis. This study explores the genetic background of ADH in France and, for the first time, the frequency of *APOE* variants in patients with a clinical diagnosis of ADH and the specific phenotypes according to the altered genes.

MATERIALS AND METHODS

Patients

Patients with an ADH phenotype were selected, without any genetic testing, from unrelated families (n = 229) residing in France and attending clinics in various parts of the country from September 2010 to April 2014. Informed consent was obtained from all patients regarding genetic testing analysis and participation in the study. It should be noted that diabetes mellitus, hypothyroidism, and increased body mass index were not exclusion criteria in the study; at this stage, patients were solely selected on the basis of an ADH phenotype.

The Dutch Lipid Clinic Network criteria were used to score all the ADH patients of more than 17 years old (n = 109), as recommended by the New French Society of Atherosclerosis. The criteria introduce a point system. In summary, a level of LDL-C from 1.55 to 1.99 g/l (4.0–4.9 mM) gives 1 point, 3 points from 2.00 to 2.49 g/l (5.0–6.4 mM), 5 points from 2.50 to 3.30 g/l (6.5–8.4 mM), and 8 points with a level more than 3.30 g/l (8.5 mM). Concerning the familial history: one parent of first degree with hypercholesterolemia (LDL-C >2g/l or 5.0 mM) gives 2 points and 1 point for first-degree familial antecedent of CVD (i.e., in the case of premature CVD, before the age of 55 and 65 years for the father and the mother of the proband, respectively). We added 2 points to the patient's score in the case of personal CVD and 6 points in presence of xanthomas. ADH is diagnosed as “definite” (patient's score >8 points), “probable” (6–8 points), and “possible” (3–5 points). The patients with score <3 points were ruled out of the study.

The child cohort (n = 120, ADH patients <17 years) was scored with a specific scoring developed by clinicians (29). A comparison between the LDL-C levels before and after a 3-month dietary period was used to score the child. The diet consisted in reducing saturated fat and cholesterol-rich foods. For example, as indicated in Benlian et al. (29), to a child with one parent with statin treatment, a definite score was attributed, if the LDL-C was greater than 2.10 g/l and remained above 1.40 g/l after the diet,

and a probable score if the LDL-C remained at a level between 1.70 and 2.09 g/l, without any decreasing after the diet.

Study design

All 229 patients were analyzed by sequencing of the entire *LDLR* gene, a fragment of exon 26 of *APOB*, and a fragment of exon 4 of *APOE* for isoform identification. The negative patients were analyzed by the multiplex ligation-dependent probe amplification (MLPA) technique to detect large rearrangements within *LDLR*. The *PCSK9* gene was further studied for patients with no identified genetic variation in loci *LDLR* and *APOB*. The entire *PCSK9* gene was sequenced in negative patients with a severe phenotype (“probable” or “definite” score), and, in the case of moderate phenotypes, only the presence of functional polymorphisms p.Arg46Leu (rs11591147), p.Ala443Thr (rs28362263), and p.Glu670Gly (rs505151) was analyzed. All the negative patients after *LDLR*, *APOB*, and *PCSK9* screening were analyzed by sequencing the entire *APOE* gene. Where a new variant or a variant of uncertain clinical significance (VUS) was found during the *LDLR* and *APOB* screening, the analysis was completed by *PCSK9* and *APOE* sequencing and MLPA analysis in the *LDLR* locus. The entire *LDLR*, *PCSK9*, and *APOE* sequencing included the promoter region and intronic boundaries (50 to 100 flanking base pairs in both sides). The 3′ untranslated regions were not entirely analyzed as the sequencing stopped around 100 base pairs after the termination codon.

Molecular analysis

Genomic DNA was extracted from peripheral blood leukocytes by using a phenol/chloroform extraction. Genotyping for the *LDLR*, a fragment of exon 26 of *APOB*, *PCSK9*, and *APOE* was carried out using primers and conditions as described in the supplementary data (supplementary Table 1). Sequencing analysis of PCR products was performed by the Sanger method using ABI 3500xL DX sequencer and the Big Dye Terminator v.3.1 cycle sequencing kit (Applied Biosystems). The MLPA was carried out to detect rearrangements within the *LDLR* in accordance with the manufacturer’s protocol (kit P062; MRC-Holland, The Netherlands). In all cases, the presence of a mutation was confirmed by an independent PCR amplification followed by sequencing or by a second MLPA analysis. The sequence variants of this study were designated according to the Human Genome Variation Society guidelines (<http://www.hgvs.org>).

Bioinformatic tools and molecular modeling

The programs SIFT (30) and PolyPhen2 (31) were used to predict possible impact of genetic variations on the structure and function of altered proteins. For splicing predictions, we used four algorithms to computationally score 5′ and 3′ splice sites. The four algorithms were based on different concepts [Neural Network Splice Prediction (NNSP), MaxEntScan (MES), Splice Site Finder Like (SSFL), and Human Splicing Finder (HSF)] included in the ALAMUT (Interactive Biosoftware v2.4.0), and the default parameter settings were used.

The prediction of changes in thermal protein stability for each observed *APOE* variant was obtained from the CUPSAT web server (32). The functional/structural consequences of the *APOE* amino acid changes were estimated using the NMR structure of the full-length isoform E3 [pdb id 2L7B (33)].

Splicing reporter minigene assay

The genomic variations identified as having a possible effect on splicing in the bioinformatics predictions (10–20% minimum score change) were analyzed by performing a splicing reporter minigene assay. Amplicons were designed that included the ex-

ons in question with a variable length of flanking 5′ and 3′ intronic bases (see primers in supplementary Table 1) and were amplified from DNA of the heterozygous patients. Wild-type and mutated PCR products were inserted in the *NdeI* restriction site of the pTB minigene vector (34) using In-Fusion HD Cloning Plus CE (Clontech Laboratories). The pTB minigene is composed of 4 exons and 3 introns, and the PCR products were inserted in the *NdeI* restriction site of the third intron. The sequence of the constructs was verified with vector-specific sequence primers surrounding the inserted amplicon. Transfection in HeLa cells using the FuGENE HD transfection reagent (Promega, The Netherlands), RT-PCR procedures, and analysis have been previously described (35, 36). RT-PCR products were analyzed by agarose gel electrophoresis and direct Sanger sequencing using pTB exonic primers, in exons 2–3 and exon 4 of the pTB vector (supplementary Figure 2).

RESULTS

Global molecular analysis of ADH in France

In this cohort of 229 patients, 105 (46%), 77 (34%), and 47 (20%) were diagnosed with definite, probable, and possible ADH, respectively. A likely pathogenic variant or a VUS was found in the four studied genes in 85 patients (81%) with a definite score, in 36 (47%) with a probable score, and in 9 (19%) with a possible score. LDL-C levels, first-degree antecedent of hypercholesterolemia, and personal or familial history of CVD for all 229 patients are given in the supplementary data (supplementary Table 2).

The relative contribution of the four examined genes to ADH in the cohort is shown in supplementary Figure 1. All the identified variants with in silico analysis results, frequency data, and references are presented in the supplementary data (supplementary Table 3).

We identified, in 116 patients of the cohort (50.6%), 91 different probable damaging variants or VUSs in *LDLR*, spanning the entire length of the gene: 13 patients with a major rearrangement (11%), 15 patients with a small deletion/insertion (13%), and 88 patients with a single sequence variant including 59 with a missense (51%), 17 with a nonsense substitution (15%), and 12 patients with a variant that could modify the natural splice site (10%).

A variant in *APOB* was identified in eight different ADH patients. The most frequent variant was the p.(Arg3527Gln) (5/8) and two patients carried another likely pathogenic variant, p.(Glu3527Trp) and p.(Arg3558Cys), all already described in ADH. The last *APOB* variant, the p.(Gln3432Glu), was identified in a patient with a pathogenic variant in *LDLR* and was described as a benign polymorphism (supplementary Table 3).

With regard to *PCSK9*, the p.Ser127Arg was present in two unrelated patients with “definite” ADH score (2/4). It is the most frequent *PCSK9* mutation causing ADH in France (9). The two other identified variants, p.(Leu41Gln) and p.(Gly516Val), have not been described before (Table 1).

The complete *APOE* was analyzed in the 106 patients for whom no change was predicted to be functionally damaging in *LDLR*, *APOB*, and *PCSK9*. We found that four patients exhibited a change in *APOE* (1.7%) (Table 2).

TABLE 1. List of new variants, possibly disease causing, identified in *LDLR* and *PCSK9*

Gene	Exon	DNA Change	Protein	Type	Predicted Effect	PolyPhen2 Prediction	SIFT Prediction	Species Conservation	Patient Score	Variant Group
<i>LDLR</i> OM IM#606945	2	c.178C>T	p.(Gln60*)	NS	Truncated				Definite	A
	4	c.680_682delinsCA	p.(Asp227Alafs*38)	Indel	Truncated				Definite	A
	4	c.686A>T	p.(?)	Splice	Crypt splice				Definite	A
	5-8	c.695-?_1186+?del	p.(?)	LR	Truncated				Definite	A
	6	c.905G>T	p.(Cys302Phe)	MS		Damaging	NT	High	Definite	B
	7	c.974G>T	p.(Cys325Phe)	MS		Damaging	NT	High	Probable	B
	8	c.1118del	p.(Gly373Valfs*40)	Indel	Truncated				Definite	A
	9	c.1201C>T	p.(Leu401Phe)	MS		Damaging	NT	High	Definite	B
	10	c.1438G>A	p.(Ala480Thr)	MS		Damaging	NT	High	Probable	B
	12	c.1730G>A	p.(Trp577*)	NS	Truncated				Definite	A
	14	c.2106G>A	p.(Met702Ile)	MS		Benign	Tolerated	Low	Possible	VUS
	15	c.2167G>T	p.(Glu723*)	NS	Truncated				Definite	A
	15	c.2211G>T	p.(Arg737Ser)	MS		Benign	Tolerated	Low	Probable	VUS
	15	c.2229_2234dup	p.(Arg744_Pro745dup)	Indel	Elongated				Possible	B
	15	c.2295_2302del	p.(Thr766Serfs*13)	Indel	Truncated				Definite	A
	15	c.2311G>A	p.(?)	Splice	Crypt splice				Definite	A
	16-18	c.2312-?_2583+?dup	p.(?)	LR	Elongated				Definite	A
17	c.2482T>A	p.(Tyr828Asn)	MS		Damaging	NT	High	Definite	B	
<i>PCSK9</i> O MIM#607786	1	c.122T>A	p.(Leu41Gln)	MS		Damaging	Tolerated	Medium	Probable	VUS
	10	c.1547G>T	p.(Gly516Val)	MS		Damaging	NT	High	Probable	B

Missense variants (MS), nonsense mutations (NS), small deletion/insertion (indel), and large rearrangements (LR) identified in *LDLR* and *PCSK9*. The effect of the variants at the protein level was predicted by SIFT (30) and PolyPhen2 (31). The term "Truncated" means truncated peptide; "Crypt splice," cryptic splice site creation; and "Elongated," elongated peptide. NT in SIFT prediction is for "not tolerated." The level of conservation between species was indicated using SIFT data: highly conserved (High) = none or 1 other amino acid found at this position, medium conserved (Medium) = 2 to 3 amino acids, and lowly conserved (Low) stands for >3 amino acids. Patient score was defined according to the Dutch score: definite >8 points, probable = 6-8 points, and possible = 3-5 points. Variant group A = null allele; group B = defective allele. The nucleotide and protein sequence variants were designated according to the Human Genome Variation Society guidelines (<http://www.hgvs.org>).

Considering that one *APOE* mutation was detected for a patient suffering from mixed dyslipidemia and not from isolated hypercholesterolemia, the frequency of *APOE* variant in our ADH cohort was recalculated to be 1.3% (3/228).

Variants functionality and new mutations identified in ADH patients

The variants found in *LDLR*, *APOB*, *PCSK9*, or *APOE* genes could be separated into four functional groups according to the ADH identification in LOVD, the in silico and in vitro analysis, and/or familial segregation studies. Group A pathogenic variants (n = 41) included major rearrangements, nonsense substitutions, frame-shift insertion/deletion and variants causing splice site abolition, positions ±1 or 2 within the consensus splice site, and other positions tested in vitro. Fifty-five patients carried one group A variant, all found in the *LDLR* gene, and certainly explained by the observed phenotype. Among group A, 10 variants in *LDLR* have never been reported before (see Table 1).

The deleterious effect predicted on splicing of three *LDLR* variants was confirmed by the splicing reporter minigene assay (Table 3). These three variants were therefore assigned to group A. The first variant, c.313+5G>T, was previously described in Moroccan FH patients (<http://www.ucl.ac.uk/ldlr/>) and predicted as deleterious via the in silico study. The minigene assay showed de facto the complete abolition of the splice site (Fig. 1A). This variant was found here in a North African patient with a "probable" ADH score. The second variant, a new substitution

c.686A>T in exon 4 of *LDLR*, was prognosticated in silico to be benign by PolyPhen2 and SIFT but foreseen to modify the natural splice site (Table 3). The minigene assay confirmed the creation of a cryptic site in position 684, the natural splice site in 694 being completely abolished (Fig. 1B). The last variant, another new *LDLR* variant c.2311G>A changing the last nucleotide of the exon 15, was forecasted to cause probable alternative splicing. Indeed, the complete abolition of the natural splice site and the creation of two cryptic sites in the positions 2311+90 and 2190 were revealed by the minigene assay (Fig. 1C).

Group B likely pathogenic variants included missense substitutions with a probable functional effect (n = 49) and in-frame insertion/deletion (n = 3). Sixty-nine ADH patients presented one variant of group B in *LDLR*, *APOB*, *PCSK9*, or *APOE*.

PolyPhen2 and SIFT programs were used to predict the pathogenicity of the missense changes. Forty-one missense substitutions, prognosticated to be deleterious by the two programs and identified in LOVD of ADH mutations in *LDLR*, *APOB*, and *PCSK9*, belong to group B. Two of variants identified in *APOE*, namely the p.(Gly145Asp) and the p.(Arg163Cys), were reported in FD or FCHL patients (6, 7), so these variants were classified in group B too. Six newly identified changes, predicted as deleterious, were also classified in group B because they occurred in a highly conserved position among species: five in *LDLR* and one in *PCSK9* (Table 1). The new in-frame duplication p.(Arg744_Pro745dup) in *LDLR* was identified in two French families: in a mother and her daughter both with a definite score and in a second family, in which just one

TABLE 2. Genotype/phenotype correlations in patients with a variant in *APOE* gene

Patient #ID	Gender	Age (years)	Genotype	Variant Group	LDL-C(g/l)	HDL (g/l)	TGs (g/l)	Predicted Protein Effect	Familial Segregation	Statin Treatment	<i>APOE</i> Isoform
#1	M	9	p.[(Arg163Cys)]; [(Arg163Cys)]	B	4.15	0.56	0.77	Probably damaging	Yes	Yes	E3E3
#1b	F	29	p.[(Arg163Cys)]; [(=)]	B	2.70	0.43	1.00	Probably damaging	Mother of patient #1	No	E3E3
#2	F	19	p.[(Leu167del)]; [(=)]	B	2.87	ND	<2.00	Truncated peptide	ND	Yes	E3E3
#3	F	6	p.[Leu46Pro]; [(=)]	VUS	1.97	0.70	0.85	Structure destabilizing	Mother carrying mutation with isolated hypercholesterolemia	No	E3E4
#4	M	43	p.[(Gly145Asp)]; [(=)]	B	>2.00	ND	>2.00	Discordance between predictions	Three children carrying no mutation (without mixed dyslipidemia)	Yes	E2E2

F, female; M, male; ND, not determined. Serum lipids levels: LDL-C, HDL, and TGs were measured without any medication or treatment. No familial or personal CVD antecedents were known for all the patients. The effect on protein of the *APOE* variants was predicted by SIFT (30) and PolyPhen2 (31) and completed by structural consequence estimation via the CUPSAT web server (32). Variant group B = defective allele. Additional information can be found in supplementary Tables 1 and 3.

Supplemental Material can be found at:
<http://www.jlr.org/content/suppl/2016/01/22/jlr.P055699.DC1.html>

child with a possible ADH was analyzed and carried this variant.

Group C included all variants that may not cause the disease (n = 8), such as the benign polymorphisms p.(Glu277Lys), p.(Asp342Asn) in *LDLR*, p.(Gln3432Glu) in *APOB*, and p.(Glu670Gly) in *PCSK9*. The benign silent or intronic variants with no consequence for splice site were also categorized in group C. We also classified two intronic and three silent mutations found in *LDLR* as benign variants, according to the in silico analysis as it did not suggest that the splicing reporter minigene assay was necessary. These variants were the c.1706-10G>A, c.941-4G>A, c.1167G>A, c.1920C>T, and c.1977C>A (see supplementary Table 4). Note that the c.1167G>A had never been described before in LOVD.

The group of VUSs included missense substitutions with possible functional effects or other intronic or exonic changes with possible effects on transcription or causing alternative splicing (n = 5). Nine ADH patients carried at least one VUS; of these, patients five had the p.(Thr726Ile) in *LDLR*. The pathogenicity of this variant is controversial (37). This variant was found in two patients with a pathogenic variant in *LDLR* and in three other patients with a probable or possible score of ADH.

Among the likely pathogenic VUSs, the p.Leu46Pro in *APOE* and the newly identified p.(Leu41Gln) in *PCSK9* were predicted to be tolerated by SIFT and possibly or probably damaging by PolyPhen2. The p.Leu46Pro in *APOE* could affect the protein structure as explained below. The p.(Leu41Gln) was carried by a 61-year-old woman with 2.5 g/l of LDL-C level and premature CVD. This patient also had the variant p.(Asp342Asn) in *LDLR* (rs139361635), which is considered to have no effect on the protein (supplementary Table 3). Unfortunately, as she did not know her family, we were unable to investigate further. Another new variant in *LDLR*, the p.(Arg737Ser), was predicted to be benign by PolyPhen2 and SIFT. However, this substitution was found in a 1-year-old baby with an LDL-C level of 7.01 g/l that could be a compound heterozygous form of FH. He inherited the p.(Arg737Ser) and a deletion causing a heterozygous frame shift from his mother and his father, respectively (Fig. 2). Antecedents of hypercholesterolemia were known in the mother's and the father's families. No deleterious effect on splicing was predicted by in silico analysis for this variant (supplementary Table 4). Further genetic studies on the complete family or in vitro analysis are required to confirm the pathogenicity of these variants.

APOE variants and structural analysis

The four variants present in *APOE* were as follows: the p.(Arg163Cys) previously described in type III dyslipidemia (38) (patients #1 and #1b); the p.(Leu167del), a 3 bp in-frame deletion described in ADH disease (4, 5) (patient #2); the rare polymorphism p.Leu46Pro (rs769452) (patient #3); and the p.(Gly145Asp) described in FD patients (6) (patient #4) (Table 2). Three of these patients (#1 to #3) are suffering from a severe form of hypercholesterolemia, and the last patient (#4) has a severe form of

TABLE 3. *LDLR* splicing mutations: in silico analysis and splicing reporter minigene assay

Mutation	In Silico Analysis				Minigene Assay
	SSFL [0–100] WT→ Mutant	MES [0–12] WT→ Mutant	NNSP [0–1] WT→ Mutant	HSF [0–100] WT→ Mutant	Observed Consequence
Donor					
313+5G>T	75 → – (Abolition)	9.9 → 1.8 (–81.5%)	0.95 → – (Abolition)	82 → 70 (–14.9%)	Complete abolition of the physiological splice site and use of the cryptic splice site at c.263
c.686A>T	– → 79 (Physiological splice site at c.694: 73)	– → 7.2 (Physiological splice site at c.694: 7.6)	– → 0.9 (Physiological splice site at c.694: 0.9)	– → 84 (Physiological splice site at c.694: 82)	Exclusive use of the cryptic splice site at c.684
c.2311G>A	82.5 → 70 (–14.7%)	9 → 1.6 (–82%)	1 → – (Abolition)	85 → 74 (–12.5%)	Complete abolition of the physiological splice site and exclusive use of two cryptic splice sites at c.2311+90 and at c.2190

Four algorithms for computational scoring of 5' (donor) and 3' (acceptor) splice sites based on different concepts: NNSP, MES, SSFL, and HSF, all included in the ALAMUT (Interactive Biosoftware v2.4.0). “–” indicates a value below the threshold. Modifications occurred only on donor splice site in all the studied variants. Value variations of natural splice site are indicated for c.313+5G>T and c.2311G>A variants and force decreasing in brackets. Value variations of the cryptic splice site at c.684 are indicated for the variant c.686A>T and values of the natural splice site in brackets.

mixed dyslipidemia. The latter was included in the cohort as suffering with severe hypercholesterolemia treated by statins, and his daughter presented a possible score for hypercholesterolemia. Biological and clinical information and familial antecedents on the four patients with a variant in *APOE* are summarized in Table 2. The mother of patient #1 was also added (identified as patient #1b), in order to examine the homozygous and heterozygous status of the p.(Arg163Cys). More precisely, patient #1, a 9-year-old boy, carried the homozygous p.(Arg163Cys) and had an LDL-C level of 4.15 g/l; his mother (patient #1b) is suffering from hypercholesterolemia with a “definite”

score (LDL-C = 2.7 g/l). Patient #2, a 19-year-old patient with a “probable” ADH score, carried the p.(Leu167del) and a silent variant c.1920C>T in *LDLR* predicted to not affect the protein or the splicing (supplementary Table 4). Patient #3 was a 6-year-old girl with a blood LDL-C level of 1.97 g/l and a clear history of FH from her mother, who carried this heterozygous variant too. Patient #4 was suffering with a severe form of mixed dyslipidemia and carried the E2E2 genotype that is known to increase TG levels.

Modeling analysis based on the NMR structure of the full-length apoE isoform E3 (33) was used for interpreting

A variant c.313+5G>T

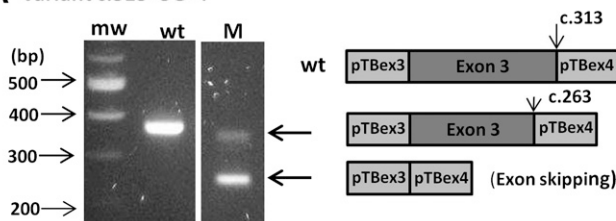

B variant c.686A>T

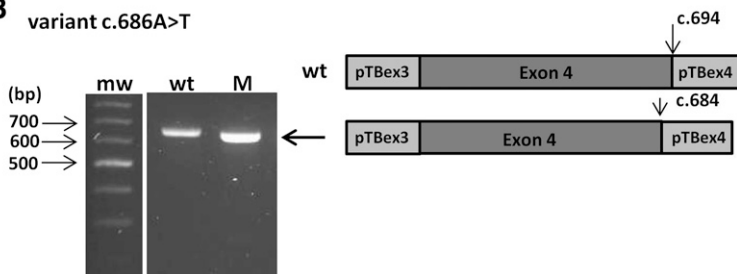

C variant c.2311G>A

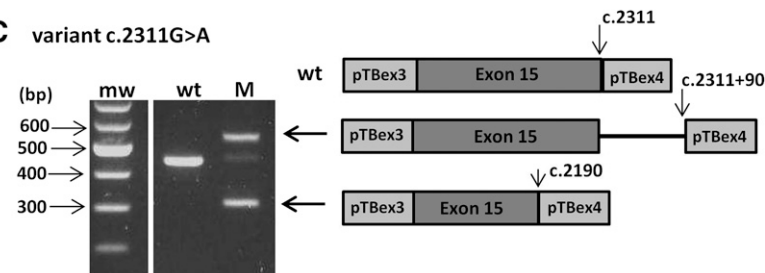

Fig. 1. Differences in RT-PCR transcripts produced by splicing reporter minigene assays with the constructions containing the three *LDLR* variants c.313+5G>T (A), c.686A>T (B), and c.2311G>A (C). RT-PCR fragments produced in the minigene assay and separated by agarose gel electrophoresis are shown at the left, and schematic representation of fragments corresponding with agarose bands are shown at the right, with flanking exons 3 and 4 of pTB vector in light gray, denoted pTBex3 and pTBex4, respectively, and the inserted *LDLR* exon in dark gray. The natural splicing sites in wild-type constructs are indicated by an arrow on the schematic representation, as well as the revealed cryptic splice sites in variant constructs, that is, c.263 in c.313+5G>T (A), c.684 in variant c.686A>T (B), and both c.2311+90 and c.2190 in c.2311G>A (C). When the exon was skipped, the RT-PCR product gave only the 248 bp transcript corresponding to the flanking exons 3 and 4 of the pTB vector. M, variant construct; mw, molecular weight marker; wt, wild-type construct.

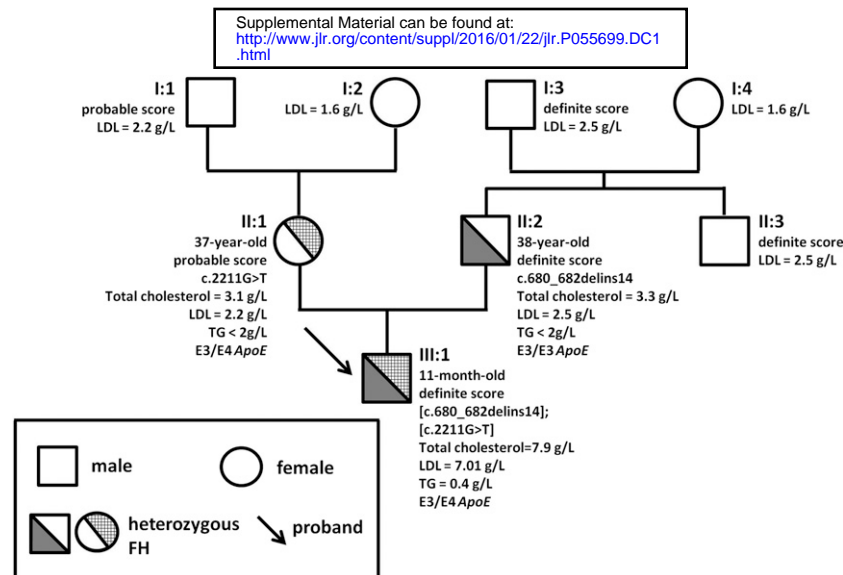

Fig. 2. Pedigree and genetic analysis in a family with a new identified variant in *LDLR*. The arrow indicates the proband: a compound heterozygous baby carrying a mutation (c.680_682delins14) and a VUS [c.2211G>T; p.(Arg737Ser)] in *LDLR*. Circles represent females and squares males. Filled symbols indicate heterozygous subjects with FH. When available, score and clinical and genetic data are indicated next to symbol. LDL, serum LDL cholesterol level; TG, serum triglycerides level. The age of the tested patients at the time of study is also given.

the effect of the four identified mutations. The mutations are all situated in the N-terminal domain (**Fig. 3**). Leu46 is located in the first α -helix H1 of N-terminal core domain, and hence the p.Leu46Pro variant inserts a proline residue into an α -helix, a situation that is generally known to be a destabilizing structural feature (39). Accordingly, the p.Leu46Pro mutation was predicted to be destabilizing by the CUPSAT program, with a large change in free folding energy of 1.4 kcal/mol. Indeed, very recently the variant Leu46Pro of apoE isoform E4 was experimentally found to be thermodynamically destabilized, more prone to proteolysis, and affected in its lipid binding properties (40). Gly145 is located within a loop region connecting helices H3 and H4; this residue being solvent-accessible, the CUPSAT program predicts a stabilizing mutation for the variant p.(Gly145Asp). Contrariwise, Arg163 and Leu167 are in the middle of the α -helix H4, precisely in the putative LDLR binding site (region 158–168). Therefore, p.(Arg163Cys) and p.(Leu167del) mutants are thought to impair LDLR binding properties of the apoE protein.

DISCUSSION

A probable damaging variant or a VUS was identified in 56.8% of our ADH French cohort. Changes in *LDLR* remained the main cause of ADH and represented 89% of the detected variants. Eighteen new possibly damaging variants were added to the last study of Marduel et al. (9), in which 175 novel mutational events had been reported from a large French cohort of ADH patients. We identified 88 different variants in *LDLR*, in addition to the 391 from the previous French study (9) and confirm that France has among the most heterogeneous *LDLR* variant spectrum in the world. Furthermore, the large number of new variants,

especially in the *LDLR* gene, which appears particularly permissive to mutational events, has to be considered for the molecular diagnosis strategy.

Among the new changes identified in *LDLR* and *PCSK9*, group A and B variants could be classified as null or defective alleles and so likely linked to the disease. We further experimentally established by splicing reporter minigene assays the splice site alteration induced by three *LDLR* variants, namely c.2311G>A, c.313+5G>T, and c.686A>T. The p.(Arg737Ser) in *LDLR* and the p.(Leu41Gln) in *PCSK9* could be classified as likely pathogenic VUSs and required further familial genetic studies or in vitro analysis to confirm the pathogenicity. Finally, one new exonic substitution, p.(Met702Ile), and one silent variant, c.1167G>A, in *LDLR* could be considered to have no effect on the protein according to the in silico analysis.

The relatively high percentage of ADH patients with no changes in the four considered genes (43.2% of the cohort) suggests the existence of other causative genes and/or polygenic causes. Recently, sequence variants in *STAP1*, encoding signal transducing adaptor family member 1, has been found in ADH patients, with a frequency of 1.2% (41). Another locus, called *HCHOLA4*, mapped at 16q22.1 region, was linked to ADH, but the causative gene has not been identified yet (42). Thus, other ADH disease-causative genes probably remain to be discovered even if the main causative genes are known (3). However, the distribution of the three common apoE isoforms could explain the cases with moderate hypercholesterolemia. Indeed, 32% of the cohort exhibited the E4 isoform, and this proportion was even greater in patients without any pathogenic variant detected (42%), while the E4 frequency in the European population is about 15% (24).

Interestingly, four unrelated patients bear a change in *APOE* (Table 2). Patient #4, suffering from a mixed dyslipidemia,

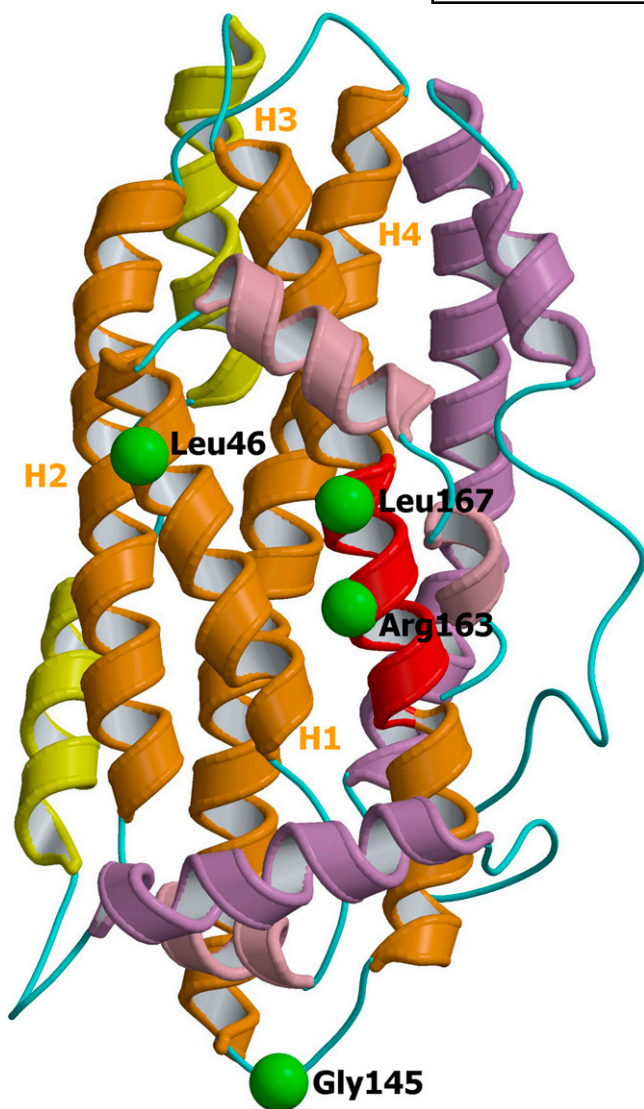

Fig. 3. Ribbon representation of apoE (pdb id 2L7B). Mutated residues encountered in the present study are represented and labeled for their localization on the 3D protein structure. The additional N-terminal helices are colored in salmon, the N-terminal domain in orange, the hinge domain (i.e., the region between the two functionally distinct domains) in yellow, and the C-terminal domain in purple. The putative LDLR binding region (residues 158–168) is shown in red. The four α -helices of the N-terminal domain are labeled as H1 to H4. The image was obtained using consecutively MolScript (47) and Raster3D (48) programs.

carried the p.(Gly145Asp) in association with the E2E2 genotype. This genotype is known to increase TG levels due to a defect in the IDL catabolism. It is established that the function of apoE protein is intimately linked to its conformational properties, so that structural perturbations brought by a single-site mutation may be accompanied by a dysfunction associated with pathogenesis (22, 43). It was difficult to evaluate the structural impact of the p.(Gly145Asp) change, but, taking into account the key role played by the charge-charge interactions in LDLR binding (44), this variant, by modifying the net charge of the apoE protein toward acidic, could reduce the affinity for LDLR. Furthermore, the homozygous E2 isoform was demonstrated

to be severely defective in in vitro LDLR binding activity compared with the E3 isoform (45). The severe mixed dyslipidemia observed in patient #4 could be explained by a quite complete apoE deficiency of the mutated allele.

Concerning the other apoE variants, the p.Leu46Pro was described as a VUS (rs769452) without clinical information. This *APOE* variant was predicted to have a destabilizing effect on the protein structure here, and this has been confirmed experimentally recently for the E4 isoform (40); our patient carried precisely the E4 isoform (patient #3). The p.(Leu167del) found in patient #2 was previously described in ADH patients (4, 5), and our in silico structural analyses suggest that this apoE variant will have impaired LDLR binding properties. The binding defect of p.(Leu167del) was, however, not demonstrated (4).

The p.(Arg163Cys) variant has previously been described in a patient with FD, who in addition bore a deleterious mutation also in *APOE* (38). Contrariwise, in our study, patient #1 carried only the homozygous C163 change in *APOE* and no other mutation. This boy and his mother are suffering an isolated severe hypercholesterolemia. Unfortunately, we cannot obtain any information about the father. As both patients came from the island of Martinique, the homozygous status could be explained by a founder effect or unknown consanguinity. The in silico structural analysis suggests that the p.(Arg163Cys) will have impaired LDLR binding properties as well.

Even if experimental investigations are needed to confirm the effects of mutations, the variants p.(Leu167del), p.(Arg163Cys), and possibly the VUS p.Leu46Pro are thought to be responsible for the observed ADH phenotype. As the TG levels were found unaffected (Table 2), the observed phenotype of patients #1, #2, and #3 could be explained by a partial apoE deficiency, contrary to patient #4. Even the homozygous form Cys163 appears to retain usual properties toward the VLDL and IDL remnants in plasma, considering the normal TG level observed in patient #1.

From our data, it appears that the homozygous form C163 in *APOE* is less severe than a homozygous FH form and looks like the *APOB* homozygous form, at least with respect to the LDL-C levels (46). Interestingly, the statin treatment was associated with good outcome in patient #1, reducing the LDL-C level from 4.15 to 2.70 g/l. Interestingly, we did not notice any notable CVD history for the four families with *APOE* changes. This observation has to be confirmed by a precise outcome as our data suggest that the *APOE* modifications in ADH could lead to less atherosclerosis than *LDLR* or *PCSK9* changes.

In conclusion, changes in *LDLR* remain the main cause of ADH accounting for 89% of the mutated ADH patients in this study. We identified 18 new possible damaging variants in *LDLR* and 2 in *PCSK9*. This study shows further that the variants in *APOE* are not an insignificant cause of ADH with a frequency of 1.3% of altered patients in our cohort. Finally, two of the three variants found in patients with isolated hypercholesterolemia were located in the LDLR binding domain of the apoE protein. **■**

The authors would like to thank the Laboratoire Commun de Biologie et Génétiques Moléculaires (LCBGM) at St. Antoine Hospital, Paris, for performing the molecular tests. The authors are indebted to all patients and clinicians for participating in this study. The authors thank Drs. N. Nunan and A. Wohlkönig for critical reading of the manuscript.

REFERENCES

- Nordestgaard, B. G., M. J. Chapman, S. E. Humphries, H. N. Ginsberg, L. Masana, O. S. Descamps, O. Wiklund, R. A. Hegele, F. J. Raal, J. C. Defesche, et al.; European Atherosclerosis Society Consensus Panel. 2013. Familial hypercholesterolaemia is underdiagnosed and undertreated in the general population: guidance for clinicians to prevent coronary heart disease: consensus statement of the European Atherosclerosis Society. *Eur. Heart J.* **34**: 3478–3490.
- Varret, M., M. Abifadel, J. P. Rabès, and C. Boileau. 2008. Genetic heterogeneity of autosomal dominant hypercholesterolemia. *Clin. Genet.* **73**: 1–13.
- Futema, M., V. Plagnol, K. Li, R. A. Whittall, H. A. W. Neil, M. Seed, S. Bertolini, S. Calandra, O. S. Descamps, C. A. Graham, et al.; Simon Broome Consortium; UK10K Consortium. 2014. Whole exome sequencing of familial hypercholesterolaemia patients negative for LDLR/APOB/PCSK9 mutations. *J. Med. Genet.* **51**: 537–544.
- Marduel, M., K. Ouguerram, V. Serre, D. Bonnefont-Rousselot, A. Marques-Pinheiro, K. E. Berge, M. Devillers, G. Luc, J.-M. Lecerf, L. Tosolini, et al. 2013. Description of a large family with autosomal dominant hypercholesterolemia associated with the APOE p.Leu167del mutation. *Hum. Mutat.* **34**: 83–87.
- Awan, Z., H. Y. Choi, N. Stitzel, I. Ruel, M. A. Bamimore, R. Husa, M. H. Gagnon, R. H. Wang, G. M. Peloso, R. A. Hegele, et al. 2013. APOE p.Leu167del mutation in familial hypercholesterolemia. *Atherosclerosis*. **231**: 218–222.
- Miller, D. B., R. A. Hegele, B. M. Wolfe, and M. W. Huff. 1995. Identification, molecular characterization, and cellular studies of an apolipoprotein E mutant (E1) in three unrelated families with hyperlipidemia. *J. Clin. Endocrinol. Metab.* **80**: 807–813.
- Solanas-Barca, M., I. de Castro-Orós, R. Mateo-Gallego, M. Cofán, N. Plana, J. Puzo, E. Burillo, P. Martín-Fuentes, E. Ros, L. Masana, et al. 2012. Apolipoprotein E gene mutations in subjects with mixed hyperlipidemia and a clinical diagnosis of familial combined hyperlipidemia. *Atherosclerosis*. **222**: 449–455.
- Guardamagna, O., G. Restagno, E. Rolfo, C. Pederiva, S. Martini, F. Abello, V. Baracco, L. Pisciotta, E. Pino, S. Calandra, et al. 2009. The type of LDLR gene mutation predicts cardiovascular risk in children with familial hypercholesterolemia. *J. Pediatr.* **155**: 199–204.
- Marduel, M., A. Carrié, A. Sassolas, M. Devillers, V. Carreau, M. Di Filippo, D. Erlich, M. Abifadel, A. Marques-Pinheiro, A. Munnich, et al.; French ADH Research Network. 2010. Molecular spectrum of autosomal dominant hypercholesterolemia in France. *Hum. Mutat.* **31**: E1811–E1824.
- van der Graaf, A., H. J. Avis, D. M. Kusters, M. N. Vissers, B. A. Hutten, J. C. Defesche, R. Huijgen, S. W. Fouchier, F. A. Wijburg, J. J. Kastelein, et al. 2011. Molecular basis of autosomal dominant hypercholesterolemia: assessment in a large cohort of hypercholesterolemic children. *Circulation*. **123**: 1167–1173.
- Medeiros, A. M., A. C. Alves, and M. Bourbon. 2015. Mutational analysis of a cohort with clinical diagnosis of familial hypercholesterolemia: considerations for genetic diagnosis improvement. *Genet. Med.* Epub ahead of print. May 28, 2015; doi:10.1038/gim.2015.71.
- Amsellem, S., D. Briffaut, A. Carrié, J. P. Rabès, J. P. Girardet, A. Fredenrich, P. Moulin, M. Krempf, Y. Reznik, B. Vialettes, et al. 2002. Intronic mutations outside of Alu-repeat-rich domains of the LDL receptor gene are a cause of familial hypercholesterolemia. *Hum. Genet.* **111**: 501–510.
- Whitfield, A. J., P. H. Barrett, F. M. van Bockxmeer, and J. R. Burnett. 2004. Lipid disorders and mutations in the APOB gene. *Clin. Chem.* **50**: 1725–1732.
- Borén, J., U. Ekström, B. Agren, P. Nilsson-Ehle, and T. L. Innerarity. 2001. The molecular mechanism for the genetic disorder familial defective apolipoprotein B100. *J. Biol. Chem.* **276**: 9214–9218.
- Gaffney, D., J. M. Reid, I. M. Cameron, K. Vass, M. J. Caslake, J. Shepherd, and C. J. Packard. 1995. Independent mutations at codon 3500 of the apolipoprotein B gene are associated with hyperlipidemia. *Arterioscler. Thromb. Vasc. Biol.* **15**: 1025–1029.
- Pullinger, C. R., D. Gaffney, M. M. Gutiérrez, M. J. Malloy, V. N. Schumaker, C. J. Packard, and J. P. Kane. 1999. The apolipoprotein B R3531C mutation. Characteristics of 24 subjects from 9 kindreds. *J. Lipid Res.* **40**: 318–327.
- Motazacker, M. M., J. Pirruccello, R. Huijgen, R. Do, S. Gabriel, J. Peter, J. A. Kuivenhoven, J. C. Defesche, J. J. Kastelein, G. K. Hovingh, et al. 2012. Advances in genetics show the need for extending screening strategies for autosomal dominant hypercholesterolaemia. *Eur. Heart J.* **33**: 1360–1366.
- Thomas, E. R., S. S. Atanur, P. J. Norsworthy, V. Encheva, A. P. Snijders, L. Game, J. Vandrovova, A. Siddiq, M. Seed, A. K. Soutar, et al. 2013. Identification and biochemical analysis of a novel APOB mutation that causes autosomal dominant hypercholesterolemia. *Mol. Genet. Genomic Med.* **1**: 155–161.
- Alves, A. C., A. Etchebarria, A. K. Soutar, C. Martin, and M. Bourbon. 2014. Novel functional APOB mutations outside LDL-binding region causing familial hypercholesterolaemia. *Hum. Mol. Genet.* **23**: 1817–1828.
- Farnier, M. 2014. PCSK9: from discovery to therapeutic applications. *Arch. Cardiovasc. Dis.* **107**: 58–66.
- Shimada, Y. J., and C. P. Cannon. 2015. PCSK9 (proprotein convertase subtilisin/kexin type 9) inhibitors: past, present, and the future. *Eur. Heart J.* **36**: 2415–2424.
- Hatters, D. M., C. A. Peters-Libeu, and K. H. Weisgraber. 2006. Apolipoprotein E structure: insights into function. *Trends Biochem. Sci.* **31**: 445–454.
- Eichner, J. E., S. T. Dunn, G. Perveau, D. M. Thompson, K. E. Stewart, and B. C. Stroehla. 2002. Apolipoprotein E polymorphism and cardiovascular disease: a HuGE review. *Am. J. Epidemiol.* **155**: 487–495.
- Khan, T. A., T. Shah, D. Prieto, W. Zhang, J. Price, G. R. Fowkes, J. Cooper, P. J. Talmud, S. E. Humphries, J. Sundstrom, et al. 2013. Apolipoprotein E genotype, cardiovascular biomarkers and risk of stroke: systematic review and meta-analysis of 14,015 stroke cases and pooled analysis of primary biomarker data from up to 60,883 individuals. *Int. J. Epidemiol.* **42**: 475–492.
- Williams, R. R., S. C. Hunt, M. C. Schumacher, R. A. Hegele, M. F. Leppert, E. H. Ludwig, and P. N. Hopkins. 1993. Diagnosing heterozygous familial hypercholesterolemia using new practical criteria validated by molecular genetics. *Am. J. Cardiol.* **72**: 171–176.
- Scientific Steering Committee on behalf of the Simon Broome Register Group. 1991. Risk of fatal coronary heart disease in familial hypercholesterolaemia. *BMJ.* **303**: 893–896.
- Scientific Steering Committee on behalf of the Simon Broome Register Group. 1999. Mortality in treated heterozygous familial hypercholesterolaemia: implications for clinical management. *Atherosclerosis*. **142**: 105–112.
- Defesche, J. C. 2000. Familial hypercholesterolemia. In *Lipids and Vascular Disease*. D. J. Betteridge, editor. Dunitz, London. 65–76.
- Benlian, P., A. Turquet, F. Carrat, S. Amsellem, L. Sanchez, D. Briffaut, and J. P. Girardet. 2009. Diagnosis scoring for clinical identification of children with heterozygous familial hypercholesterolemia. *J. Pediatr. Gastroenterol. Nutr.* **48**: 456–463.
- Kumar, P., S. Hinokoff, and P. C. Ng. 2009. Predicting the effects of coding non-synonymous variants on protein function using the SIFT algorithm. *Nat. Protoc.* **4**: 1073–1081.
- Adzhubei, I. A., S. Schmidt, L. Peshkin, V. E. Ramensky, A. Gerasimova, P. Bork, A. S. Kondrashov, and S. R. Sunyaev. 2010. A method and server for predicting damaging missense mutations. *Nat. Methods.* **7**: 248–249.
- Parthiban, V., M. M. Gromiha, and D. Schomburg. 2006. CUPSAT: prediction of protein stability upon point mutations. *Nucleic Acids Res.* **34**: W239–W242.
- Chen, J., Q. Li, and J. Wang. 2011. Topology of human apolipoprotein E3 uniquely regulates its diverse biological functions. *Proc. Natl. Acad. Sci. USA.* **108**: 14813–14818.
- Baralle, D., and M. Baralle. 2005. Splicing in action: assessing disease causing sequence changes. *J. Med. Genet.* **42**: 737–748.
- Crehate, H., P. Latour, V. Bonnet, S. Attarian, P. Labauge, N. Bonello, R. Bernard, G. Millat, R. Rousson, and D. Bozon. 2010. U1 snRNA mis-binding: a new cause of CMT1B. *Neurogenetics.* **11**: 13–19.
- Millat, G., E. Lafont, S. Nony, I. Rouvet, and D. Bozon. 2015. Functional characterization of putative novel splicing mutations in the cardiomyopathy-causing genes. *DNA Cell Biol.* **34**: 489–496.

37. Graham, C. A., B. P. McIlhatton, C. W. Kirk, E. D. Beattie, K. Lyttle, P. Hart, R. D. Neely, I. S. Young, and D. P. Nicholls. 2005. Genetic screening protocol for familial hypercholesterolemia which includes splicing defects gives an improved mutation detection rate. *Atherosclerosis*. **182**: 331–340.
38. Lohse, P., W. A. Mann, E. A. Stein, and H. B. Jr. Brewer. 1991. Apolipoprotein E-4Philadelphia (Glu13→Lys, Arg145→Cys). Homozygosity for two rare point mutations in the apolipoprotein E gene combined with severe type III hyperlipoproteinemia. *J. Biol. Chem.* **266**: 10479–10484.
39. Barlow, D. J., and J. M. Thornton. 1988. Helix geometry in proteins. *J. Mol. Biol.* **201**: 601–619.
40. Argyri, L., I. Dafnis, T. A. Theodossiou, D. Gantz, E. Stratikos, and A. Chroni. 2014. Molecular basis for increased risk for late-onset Alzheimer disease due to the naturally occurring L28P mutation in apolipoprotein E4. *J. Biol. Chem.* **289**: 12931–12945.
41. Fouchier, S. W., G. M. Dallinga-Thie, J. C. Meijers, N. Zelcer, J. J. Kastelein, J. C. Defesche, and G. K. Hovingh. 2014. Mutations in STAP1 are associated with autosomal dominant hypercholesterolemia. *Circ. Res.* **115**: 552–555.
42. Marques-Pinheiro, A., M. Marduel, J. P. Rabès, M. Devillers, L. Villéger, D. Allard, J. Weissenbach, M. Guerin, Y. Zair, D. Erlich, et al.; French Research Network on ADH. 2010. A fourth locus for autosomal dominant hypercholesterolemia maps at 16q22.1. *Eur. J. Hum. Genet.* **18**: 1236–1242.
43. Mahley, R. W., K. H. Weisgraber, and Y. Huang. 2009. Apolipoprotein E: structure determines function, from atherosclerosis to Alzheimer's disease to AIDS. *J. Lipid Res.* **50**: S183–S188.
44. Sjouke, B., D. M. Kusters, I. Kindt, J. Besseling, J. C. Defesche, E. J. Sijbrands, J. E. Roeters van Lennep, A. F. Stalenhoef, A. Wiegman, J. de Graaf, et al. 2014. Homozygous autosomal dominant hypercholesterolaemia in the Netherlands: prevalence, genotype-phenotype relationship, and clinical outcome. *Eur. Heart J.* **36**: 560–565.
45. Zaiou, M., K. S. Arnold, Y. M. Newhouse, T. L. Innerarity, K. H. Weisgraber, M. L. Segall, M. C. Phillips, and S. Lund-Katz. 2000. Apolipoprotein E-low density lipoprotein receptor interaction: influences of basic residue and amphipathic alpha-helix organization in the ligand. *J. Lipid Res.* **41**: 1087–1095.
46. Weisgraber, K. H., T. L. Innerarity, and R. W. Mahley. 1982. Abnormal lipoprotein receptor-binding activity of the human E apoprotein due to cysteine-arginine interchange at a single site. *J. Biol. Chem.* **257**: 2518–2521.
47. Kraulis, P. J. 1991. MOLSCRIPT: a program to produce both detailed and schematic plots of protein structures. *J. Appl. Crystallogr.* **24**: 946–950.
48. Merritt, E. A., and D. J. Bacon. 1997. Raster3D: photorealistic molecular graphics. *Methods Enzymol.* **277**: 505–524.