



HAL
open science

Recent Advances in Hydrometallurgy for the Development of a Sustainable Production of Lithium-Ion Batteries

Alexandre Chagnes

► **To cite this version:**

Alexandre Chagnes. Recent Advances in Hydrometallurgy for the Development of a Sustainable Production of Lithium-Ion Batteries. ALTA 2019 - Lithium processing conference, May 2019, Perth, Australia. hal-02270375

HAL Id: hal-02270375

<https://hal.univ-lorraine.fr/hal-02270375>

Submitted on 26 Aug 2019

HAL is a multi-disciplinary open access archive for the deposit and dissemination of scientific research documents, whether they are published or not. The documents may come from teaching and research institutions in France or abroad, or from public or private research centers.

L'archive ouverte pluridisciplinaire **HAL**, est destinée au dépôt et à la diffusion de documents scientifiques de niveau recherche, publiés ou non, émanant des établissements d'enseignement et de recherche français ou étrangers, des laboratoires publics ou privés.

RECENT ADVANCES IN HYDROMETALLURGY FOR THE DEVELOPMENT OF A SUSTAINABLE PRODUCTION OF LITHIUM-ION BATTERIES

By

Alexandre Chagnes

Université de Lorraine, CNRS, GeoRessources, France

Presenter and Corresponding Author

Alexandre Chagnes

alexandre.chagnes@univ-lorraine.fr

ABSTRACT

It is expected that the small world of lithium will boom due to the emergence of electric vehicles. Likewise, it is expected that the demand in cobalt and nickel will be increased by 31% and 69% between 2017 and 2030, respectively. The development of sustainable and economic processes to recover lithium, cobalt, nickel and manganese from primary and secondary resources is therefore of great importance, especially because of a huge demand of these metals to produce lithium-ion batteries. This paper gives recent advances in the development of hydrometallurgical processes for the sustainability of battery raw materials.

Keywords: copper recovery, ammonia leach, solvent extraction, electrowinning, process development, pilot plant

INTRODUCTION

In 2013, the global sales of Li batteries reached nearly 12 billion US\$ and this market is anticipated to reach about 24 billion US\$ by 2020, driven by the growing use of Li-ion batteries in hybrid electrical vehicles (HEV) and fully electrical vehicles (EV) as well in many other applications. Lithium is used in many applications including glass and ceramics, lithium batteries, lithium greases, air treatment, steel and aluminium industry and pharmaceutical industry and polymers⁽¹⁾⁽²⁾. Figure 1 shows an overview of the linkages between the natural lithium sources (brines and minerals), the main derived primary products (lithium carbonate, hydroxide, chloride, metallic lithium), the secondary derived, products and their respective main uses and applications. The main market for lithium in the next decades is lithium-ion batteries due to the emergence of electric vehicles and the development of energetic transition. In particular, many researches focus on the search for high energy density batteries for electric mobility. However, this race of high-energy density storage technologies must not be achieved at the detriment of safety and sustainability of lithium-ion batteries. Reducing the environmental footprint of lithium-ion batteries remains a priority. Sustainability of batteries can only be achieved providing that each stage of the value chain is optimized in terms of efficiency, energy and resources consumption, gas and effluent emission, material production process, *etc.* Further, the vision of the circular economy encourages the closing of loops by means of recycling, which challenges today's value chains and its various actors⁽³⁾. For these changes in the value chain to take place, not only technological achievements are necessary but innovations in the supply chain system and in business models for both energy storage devices and its applications are most likely required.

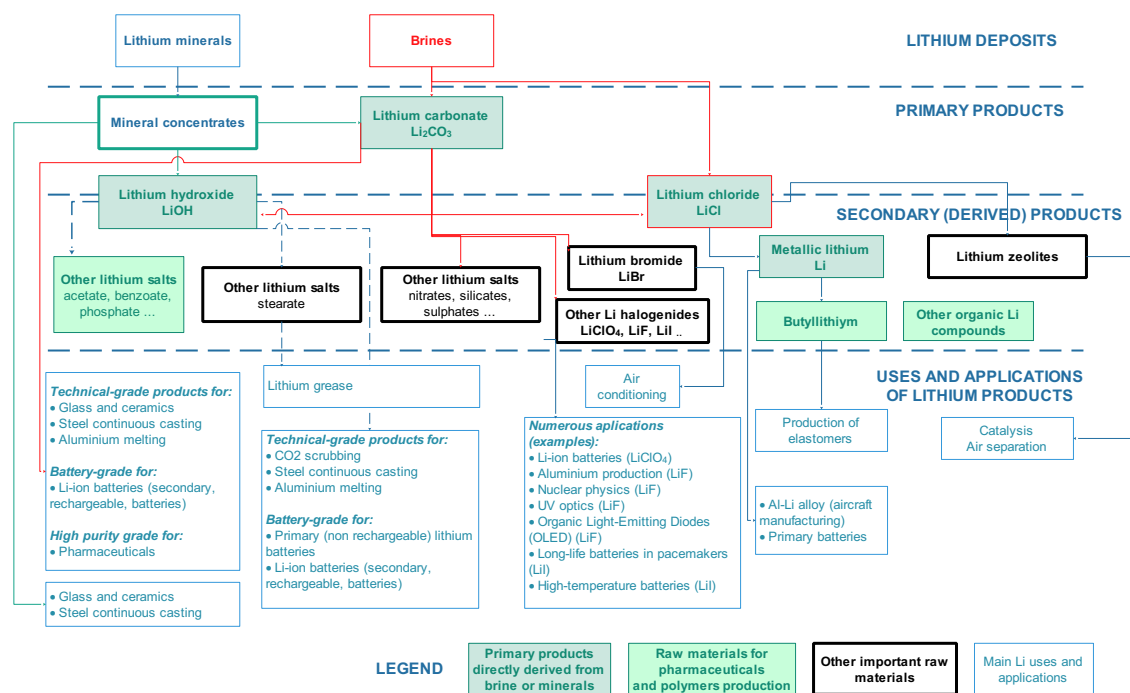

Figure 1. Supply chains linking lithium deposits to lithium applications and uses⁽²⁾.

The huge market of electric vehicle will be responsible for an important rise of cobalt, nickel, manganese and lithium demand since current batteries use these raw materials. For this reason, the future demand of cobalt, nickel and lithium will likely increase by 31%, 69% and 46% between 2017 and 2030, respectively⁽⁴⁾. While 130 million electric vehicles could circulate around the world by 2030, Europe estimates the need for cobalt for the automotive sector between 1.6 and 2.1 million tonnes by 2030, an annual demand that would rise from 6650 tons in 2017 to 300,000-400,000 tons. In Europe and according to the scenarios, demand is estimated between 40,000 and 120,000 tons per year by 2030. Therefore, tightness in metal market will be strong in the next decade and supply risks have to be anticipated, especially in European countries where there is no or few cobalt, nickel, manganese and lithium deposits. In Europe, 239 deposits containing cobalt have been identified. Some countries like Finland and Sweden are already mining the ore. Today, the annual production of cobalt in the European Union is about 2,300 tons per year, and it will be insufficient to cover a demand nine times higher. Combined with the establishment of an efficient recycling sector, the accelerated exploitation of cobalt deposits in Europe could cover about 15% of the demand of the old

continent by 2030. Europe will, however, remain heavily dependent on imports. In this context, it appears strategic to consolidate trade agreements with countries such as Australia or Canada. The same scenario is expected for lithium since European lithium importation reaches 86% to face up its needs. However, a large lithium reserve exists in Europe, and more particular in Portugal where two large mines could start operating in 2020. For this goal, it appears of great importance to develop breakthrough processes in order to reduce operation costs since the production of lithium extracted from Portuguese granite rock is about 2.5 times more expensive than that produced from Chilean brine deposits.

More generally, there is a need to develop efficient, selective and sustainable hydrometallurgical processes for the recovery of these metals from primary and secondary resources. This paper highlights a few recent advances, which contribute to improve the current processes by optimizing them or that pave the way for breakthrough processes.

COBALT, NICKEL AND MANGANESE SEPARATION

Nickel is mainly extracted from laterite and sulphide ores while cobalt is mainly extracted from linneaita and cobaltine, and manganese is found in the rocks of pyrolusite, haussmannite and braunite⁽⁵⁾. Pyrometallurgy is still the preferred technology to recover these metals in addition to their recovery as a by-product from copper ores. Nevertheless, laterite ores containing both nickel, cobalt and other metals of economic interest are increasingly being treated by hydrometallurgical methods or methods combining both pyrometallurgy and hydrometallurgy⁽⁶⁾. However, the trend is changing in favor of hydrometallurgy because of the negative environmental impact of pyrometallurgy and its high energy consumption, and because pyrometallurgy is not adaptable to extract metals from the new and leaner polymetallic resources.

The development of new hydrometallurgical processes for the recovery of cobalt, nickel and manganese from new polymetallic ores while keeping as low as possible the environmental footprint and the cost of the process is therefore a central concern. While cobalt and nickel separation in acidic chloride and sulfate media is easily performed by liquid-liquid extraction by using the well-established Cyanex® 272 extractant (bis-(2,4,4-trimethylpentyl) phosphinic acid), the separation of manganese from cobalt-nickel by solvent extraction is more difficult. Such a separation is presently performed using precipitation unit operations, which may increase the complexity of the process and its cost. The development of new extracting agents and the corresponding flowsheets incorporating them is particularly important to achieve the desired selectivity. Chagnes et al.⁽⁷⁻⁹⁾ recently published papers on the use of the new extracting agents reported in Figure 2 for the extraction of Ni(II), Co(II) and Mn(II) from acidic chloride media by two new extractants.

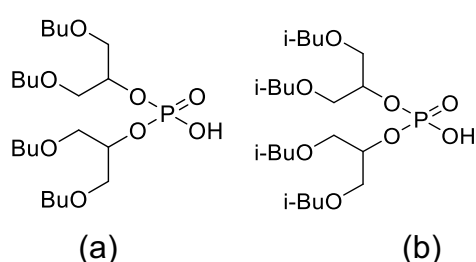

Figure 2. Chemical structure of (a) bis(1,3-dibutoxypropan-2-yl) phosphoric acid (BiDiBOPP) and (b) bis(1,3-diisobutoxypropan-2-yl) phosphoric acid (IPA).

Figure 3 shows the extraction isotherms of Co(II), Ni(II) and Mn(II) from acidic chloride solution by Cyanex® 272 and the two extractants synthesized in the present work, i.e. BiDiBOPP and IPA. The presence of oxygen atoms in the chemical structure of BiDiBOPP and IPA shifts the extraction curves of Co(II), Ni(II) and Mn(II) towards the low pH values since pH of half extraction $pH_{1/2}$ =3.8, 4.2 and 6.5 for Co(II), Mn(II) and Ni(II), respectively, when Cyanex® 272 is used whereas $pH_{1/2}$ =2.3, 1.5 and 2.5 and $pH_{1/2}$ =2.3, 1.5 and 3 for the same metals with BiDiBOPP and IPA respectively. Such an observation can be explained by a decrease of the pKa values due to the presence of oxygen atoms in the alkyl chains of the extractant⁽¹⁰⁾. Extraction properties of BiDiBOPP and IPA are very close as they have similar chemical structure. Therefore, no significant influence of the branching of the alkyl chains of the organophosphorus compounds on the extraction properties of Co(II), Ni(II) and Mn(II) is observed. The decrease of the pH of extraction when Cyanex® 272 is

replaced by BiDiBOPP and IPA is interesting potentially for reducing the extraction process operating cost.

Indeed, solvent extraction is used to recover metals from leaching solutions which are usually acidic. Therefore, it is necessary to add an alkaline reagent to increase the pH of the leaching solution in order to perform the extraction. For instance, the use of Cyanex® 272 to extract Co(II) and Ni(II) requires an increase of the pH of the leach solution from around 1-2 to 4.2 and 6.5 respectively. By replacing Cyanex® 272 with BiDiBOPP or IPA, less neutralizing alkaline reagent should be needed as it will only be necessary to raise the pH from 1-2 to 2.3 and 3, respectively.

Furthermore, it is interesting to point out that the use of BiDiBOPP or IPA allows the separation of Mn(II) from Co(II) and Ni(II) to be envisaged, since $pH_{1/2}$ for Mn(II) extraction is 1.5 and $pH_{1/2}$ values for Co(II) and Ni(II) are 2.3 and 2.5-3. Conversely, Mn(II)-Co(II) separation using Cyanex® 272 is not possible since the extraction curves of Co(II) and Mn(II) are too similar in terms of percent extraction versus pH.

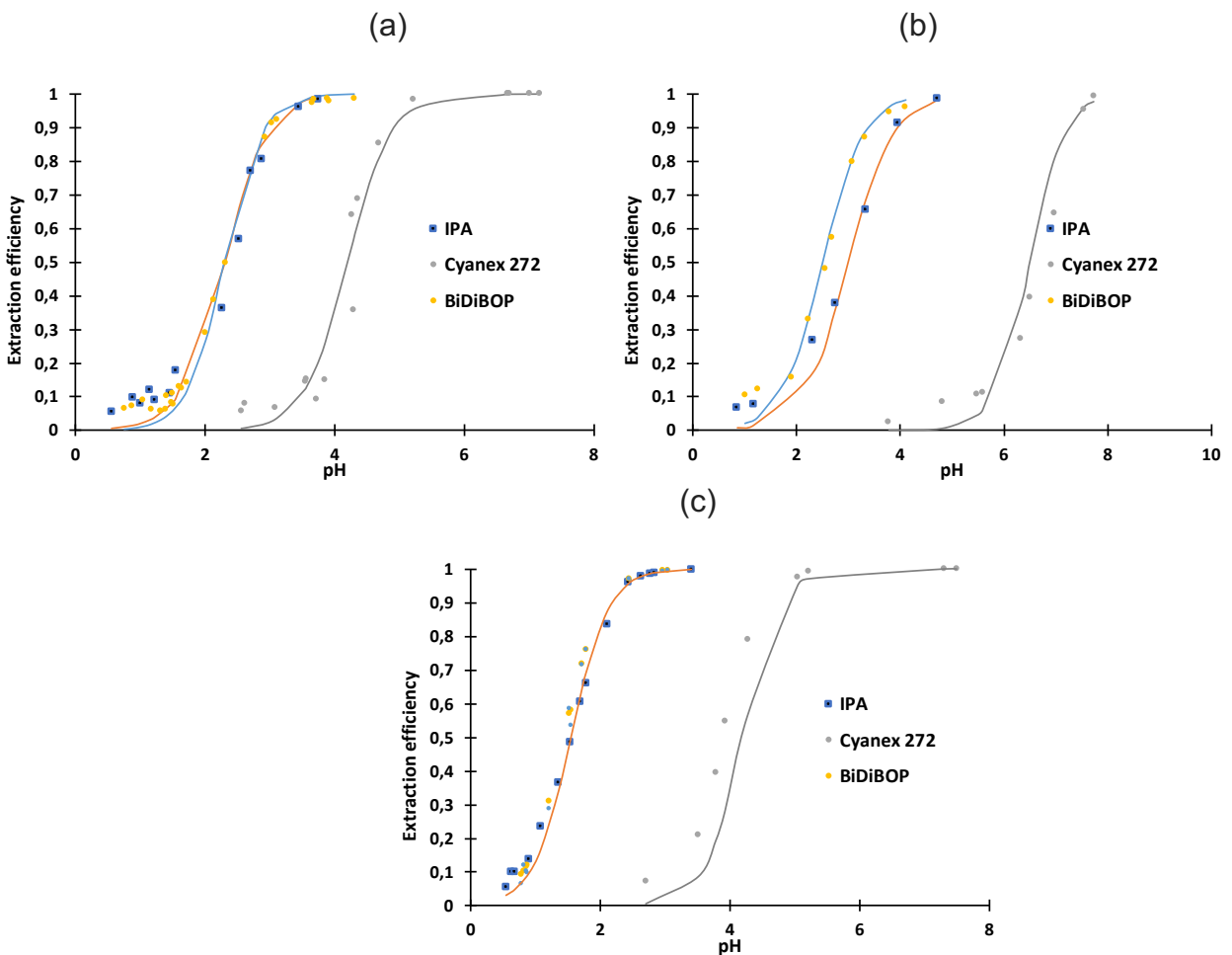

Figure 3. Extraction efficiency of (a) Co(II), (b) Ni(II) and (c) Mn(II) by Cyanex® 272, BiDiBOPP and IPA diluted in kerosene as a function of equilibrium pH. Temperature=25 °C; phase volume ratio $V_{org}/V_{aq}=1$; chloride concentration=1 M.

Based on the above results, it is therefore possible to envisage the flowsheet proposed in Figure 4 to separate Co(II)-Ni(II)-Mn(II) mixtures in acidic chloride media without performing any precipitation operation. For example, in recycling cathode material from lithium-ion batteries, there are no elements present other than Co, Ni and Mn. For ores, additional treatment might be needed because of the presence of other impurities such as iron that must be removed.

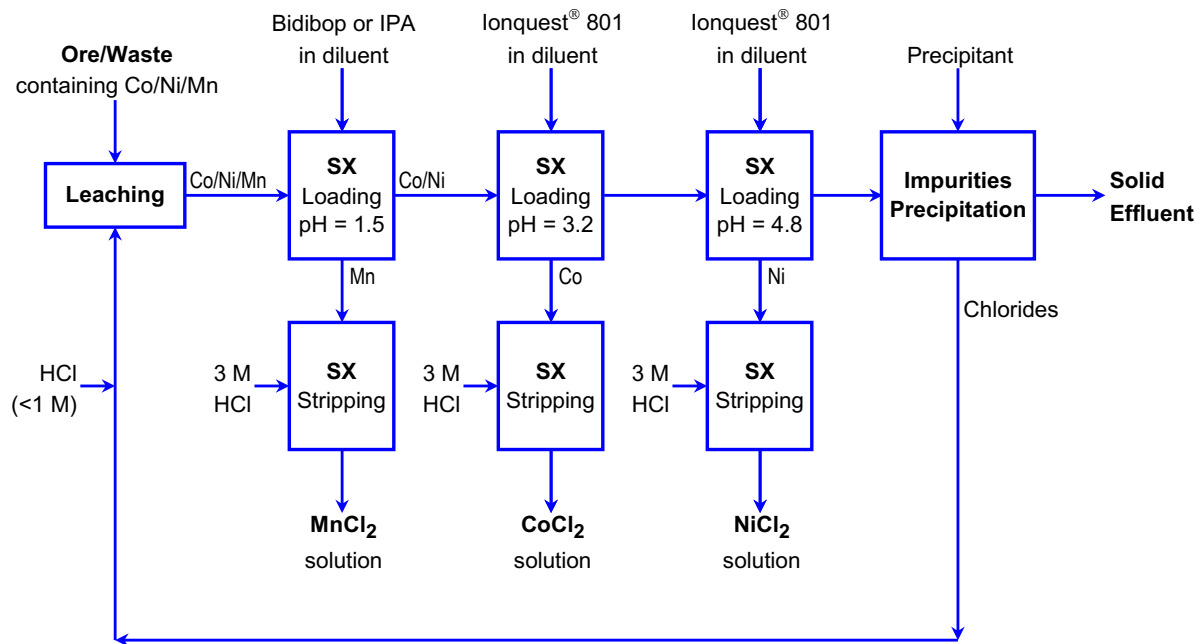

Figure 4. Proposed flowsheet for separation of Co, Mn and Ni

LITHIUM EXTRACTION

With regard to primary extraction, lithium is produced commercially from two main sources, i.e. mineral ore such as spodumene ($\text{LiAlSi}_2\text{O}_6$) and petalite ($\text{LiAlSi}_4\text{O}_{10}$), and nature mixed alkali/alkaline earth brines. New minerals are also being considered such as Jadarite which is a lithium sodium borosilicate. The other source of lithium are brines; subsurface brines have become the dominant raw material for lithium carbonate production worldwide because of lower production costs compared with the mining and processing costs associated with hard-rock ores. Nevertheless, by considering the increasing demand for lithium and lithium salts, the current production levels of this metal should be further improved. Thus, lithium ores need to be considered as mainstream resources. Among the different lithium ores, the mineral spodumene is one of the most interesting sources of lithium readily available in Australia.

Two patented processes are used for recovery of the lithium from spodumene⁽¹¹⁻¹³⁾:

- In the first process, limestone and spodumene concentrates are mixed and calcined. The alpha-spodumene is thus transformed into the beta form while decrepitation occurs and the CaCO_3 is decomposed into CaO. Ideally, part of the resulting CaO reacts with the SiO_2 in the spodumene to form 2CaO-SiO_2 or 3CaO-SiO_2 and the Al_2O_3 reacts with the Li_2O to form LiAlO_2 . The calcined material is leached with water, LiOH coming off in solution.
- In the second process, an acid-leach route is implemented after roasting the spodumene concentrate for conversion of the naturally occurring alpha-spodumene to the beta-spodumene since alpha-spodumene is a refractory material in acidic leaching. Beneficiation of spodumene ores (2.8-4.2% Li_2O) are performed by using gravity, heavy media, flotation, and magnetic separation processes to produce technical-grade lithium concentrates or chemical-grade lithium concentrates depending on market demand. In the acid leach process, the concentrate is roasted at 1070-1090 °C to convert the spodumene to the beta form. The inversion is accompanied by severe decrepitation, which leaves the spodumene very finely pulverized and thus facilitates the extraction of the lithium. The calcined ore is heated with H_2SO_4 to approximately 250 °C, and then water is added at 90 °C to dissolve lithium sulphate, which is highly soluble in water¹. Impurities such as Fe, Al, Mg, Ca, etc., are removed as hydroxides at pH 12 by adding NaOH or precipitated using limestone due to low cost and solid-liquid separation challenges. The purified leach liquor is afterward treated using ion exchange to concentrate lithium. Carbonation of the lithium-rich

¹ A. Chagnes, J. Swiatowska (Editeurs), "Lithium Process Chemistry: Resources, Extractions, Batteries and Recycling", Elsevier, 2015, 313 pages (ISBN: 978-0-12-801417-2).

solution is thereafter applied to precipitate lithium carbonate. Both battery-grade (99.5%) Li_2CO_3 and Na_2SO_4 as a by-product are produced from this process. In certain cases, an electro dialysis module can be included to produce a LiOH solution from purified Li_2SO_4 solution obtained after impurities are removed by precipitation and ion exchange. The LiOH solution generated is then heated to concentrate Li values and a crystallization stage is finally conducted to yield $\text{LiOH}\cdot\text{H}_2\text{O}$. High purity Li_2CO_3 and $\text{LiOH}\cdot\text{H}_2\text{O}$ of >99.9% grade can be produced from this process.

Lithium recovery from brines relies on solar evaporation before a refining stage consisting of the implementation of solvent and/or resin extraction steps in order to produce battery-grade lithium salts. Solar evaporation is very cheap, but it requires more than one year between starting the operation and the first grams of lithium salt produced. In order to reduce the production time, two innovative processes have been recently developed by Eramet⁽¹⁴⁾⁽¹⁵⁾ and Solvay-Tenova⁽¹⁶⁾⁽¹⁷⁾:

Eramet Process

ERAMET started developing a lithium production project in 2016 in order to extract lithium from brines located in the Andean cordillera area (Salta, north-western Argentina). The resources of the Centenario-Ratones deposit are very significant and justify a large industrial production of 20,000 tonnes of lithium carbonate for several decades. The innovation of this process is based on the use of very selective sorption material towards lithium implemented in a solid-liquid extraction stage, solvent extraction and membrane processes. In 2016, the ERAMET Lithium project enters the final stages of its development.

In this process, the brine is pumped from a depth of 200 m and is fed into the lithium extraction unit which consist in a solid/liquid extraction by means of an appropriate sorbent ($\text{LiCl}\cdot 2\text{Al}(\text{OH})_3\cdot n\text{H}_2\text{O}$) patented by Eramet⁽¹⁸⁾. During this step, lithium is selectively extracted towards calcium, magnesium, boron and sulphates. The brine after lithium extraction is reinjected in the brine field aquifer via infiltration so that the water balance of the brine field is not affected (unlike with conventional solar evaporation). After elution of the sorbent loaded with lithium, the solution is concentrated by means of reverse osmosis and the resulted concentrated solution is afterwards purified by using solvent extraction to remove boron and ion exchange extraction in order to remove traces of calcium and magnesium before adding sodium carbonate in order to produce lithium carbonate salts for glass, ceramic and greases industry as well as lithium-ion battery industry.

Solvay-Tenova Process

Solvay and Tenova have recently developed a new technology for the recovery of lithium from brine based on the use of Cyanex® 936 as extraction solvent, which exhibits a good extraction efficiency for lithium (80% at pH 9) and high selectivity towards potassium, sodium and bore. This solvent extraction stage is combined with membrane technologies and electrolysis. Calcium and magnesium are first removed from the brine by a membrane process. The brine without magnesium and calcium is afterwards sent into an electrolysis cell in order to generate chlorine which is used to produce hydrochloric acid used for stripping in the solvent extraction process. The PLS containing lithium (without calcium and magnesium) is sent to the solvent extraction stage that relies on the use of Cyanex® 936. After scrubbing and stripping with hydrochloric acid, lithium chloride is directly produced, or the stream can be sent to the precipitation stage with soda ash in order to produce lithium carbonate or to the electrolysis stage in order to produce hydrochloric acid and lithium hydroxide. This process is also interesting because it allows extracting lithium without affecting the brine field like with the Eramet process, it avoids any production delay due to solar evaporation, and because it is very versatile since it permits to produce different products without significantly changing the process.

REFERENCES

1. Pillot C., 2014. Battery Market Development for Consumer Electronics, Automotive, and Industrial: Materials Requirements and Trends - Presentation given at the Advanced Automotive Battery Conference 2014 - AVICENNE Energy (Paris, France).
2. Chagnes, A., Swiatowska, J. (Ed.), 2015. Lithium Process Chemistry:Resources, Extractions, Batteries and Recycling, Elsevier, 313 pages (ISBN: 978-0-12-801417-2).

3. Chagnes, A., Pospiech, B., 2013. A brief review on hydrometallurgical technologies for recycling spent lithium-ion batteries. *Journal of Chemical Technology and Biotechnology* 88, 1191-1199.
4. Pillot, C., 2018. R&D Stream Lithium-Ion Development & Commercialization Delivering Higher Performance at Lower Cost (Fort Lauderdale, Florida, USA), 28-29 March 2018, "The rechargeable battery market and main trends 2017-2015".
5. Lateef Ibrahim, B. A., Adekola, F. A., Bale, R. B., Ghosh, M. K., Sheik, Olushola, A. R. S. R. Pradhan, Ayanda, S. and Folorunsho, I. O. (2014). Hydrometallurgical Processing of Manganese Ores: A Review. *Journal of Minerals and Materials Characterization and Engineering* 2 (3):230-247.
6. Chagnes, A., 2015. Fundamentals in electrochemistry and hydrometallurgy. In: A. Chagnes, J. Swiatowska, éditeurs, *Lithium Process Chemistry: Resources, Extractions, Batteries and Recycling*. 1st ed. Amsterdam: Elsevier, 2015 (ISBN: 978-0-12-801417-2). p. 41-80.
7. Omelchuk, K., Szczepański, P., Shrotre, A., Haddad, M., Chagnes, A., 2017. Effects of structural changes of new organophosphorus cationic exchangers on solvent extraction of cobalt, nickel and manganese from acidic chloride media. *RSC Advances* 7, 5660-5668.
8. Omelchuk, K., Stambouli, M., Chagnes, A., 2018. Investigation of aggregation and acid dissociation of new cationic exchangers for liquid-liquid extraction. *Journal of Molecular Liquids* 262, 111-118.
9. Omelchuk, K., Chagnes, A., 2018. New cationic exchangers for the recovery of cobalt(II), nickel(II) and manganese(II) from acidic chloride solutions: Modelling of extraction curves. *Hydrometallurgy* 180, 96-103.
10. Beltrami, D., Chagnes, A., Haddad, M., Laureano, H., Mokhtari, H., Courtaud, Jugé, S. and Cote, G. (2013). Development of New Cationic Exchangers for the Recovery of Uranium (VI) from Concentrated Phosphoric Acid". *Sep. Sci. Technol.* 48(3) 480-486.
11. Davidson, C.F., 1981. Recovery of lithium from low-grade ores. Application No. 116697, Publication No. US4285914, International Classifications: C01D 3/08
12. Medina, L., El-Naggar, M., 1984. *Metallurgical and Materials Transactions B* 15B, 725– 726.
13. Dunn, W.E., Van Jahnke, J., 2005. Cyclical vacuum chlorination processes, including lithium extraction. WO 2005/094289 A2.
14. <http://www.eramet.com/lithium> (Feb 2018).
15. http://www.eramet.com/sites/default/files/infog-lithium-en_0.pdf (Fev 2018); S. Lebouil, 2018, <http://www.pole-avenia.com/wp-content/uploads/2018/07/7-ERAMET.pdf>
16. Lipp, J., 2014. LISX™ A new SX Technology for Lithium Recovery, Proceeding of the 7th International Symposium Hydrometallurgy 2014, Canadian Institute of Mining, 395-402.
17. Cohen, L., T. McCallum, T., O. Tinkler O., Szolga, W., 2018. Technological Advances, Challenges and Opportunities in Solvent Extraction from Energy Storage Applications", *Extraction 2018*, Davis B. et al. (eds), The Minerals, Metals & Materials Series. Springer, Cham, p. 2033-2045.
18. Boualleg, M., Lafon, O., Burdet, F., Soulairol, R., 2015. Procédé de préparation d'un matériau absorbant mis en forme en l'absence de liant et procédé d'extraction de lithium à partir de solutions salines utilisant ledit matériau. Patent W02015097202.