



**HAL**  
open science

## Sensitivity of pipelines with steel API X52 to hydrogen embrittlement

Julien Capelle, J Gilgert, I Dmytrakh, G Pluvinage

► **To cite this version:**

Julien Capelle, J Gilgert, I Dmytrakh, G Pluvinage. Sensitivity of pipelines with steel API X52 to hydrogen embrittlement. *International Journal of Hydrogen Energy*, 2008, 33 (24), pp.7630-7641. 10.1016/j.ijhydene.2008.09.020 . hal-02970925

**HAL Id: hal-02970925**

**<https://hal.univ-lorraine.fr/hal-02970925v1>**

Submitted on 19 Oct 2020

**HAL** is a multi-disciplinary open access archive for the deposit and dissemination of scientific research documents, whether they are published or not. The documents may come from teaching and research institutions in France or abroad, or from public or private research centers.

L'archive ouverte pluridisciplinaire **HAL**, est destinée au dépôt et à la diffusion de documents scientifiques de niveau recherche, publiés ou non, émanant des établissements d'enseignement et de recherche français ou étrangers, des laboratoires publics ou privés.

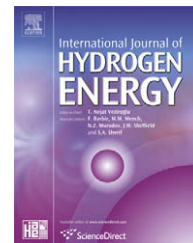
Available at [www.sciencedirect.com](http://www.sciencedirect.com)journal homepage: [www.elsevier.com/locate/he](http://www.elsevier.com/locate/he)

# Sensitivity of pipelines with steel API X52 to hydrogen embrittlement

J. Capelle<sup>a</sup>, J. Gilgert<sup>a</sup>, I. Dmytrakh<sup>b</sup>, G. Pluvinage<sup>a,\*</sup>

<sup>a</sup>Laboratoire de Fiabilité Mécanique - Université Paul Verlaine Metz et Ecole Nationale d'Ingenieurs de Metz, Ile du Saulcy, 57045 Metz, France

<sup>b</sup>Karpenko Physico-Mechanical Institute of National Academy of Sciences of Ukraine, 5 Naukova Street, 79601 Lviv, Ukraine

## ARTICLE INFO

### Article history:

Received 22 May 2008

Received in revised form

1 September 2008

Accepted 1 September 2008

Published online ■

### Keywords:

Notched pipe

Gaseous hydrogen

Burst pressure

Cathodic hydrogenating of metal

Hydrogen concentration

Current density

Acoustic emission

Static load

Critical stress

Work of local fracture

NATURALHY

## ABSTRACT

The following cases of hydrogen influence on pipeline metal were considered: gaseous hydrogen under internal pressure in notched pipes and electrochemically generated hydrogen on external pipe surface from soil aqueous environment. The burst tests of externally notched pipes under pressure of hydrogen and natural gas (methane) were carried out after the pipe has been exposed to a constant “holding” pressure. It has been shown that even for relatively “soft” test conditions (holding pressure  $p = 20$  bar and ambient temperature) the gaseous hydrogen is able to penetrate into near surface layers of metal and to change the mechanism of local fracture at notch. The sensitivity to hydrogenating of given steel in deoxygenated, near-neutral pH NS4 solution under soft cathodic polarisation was studied and the assessment local strength at notches in pipeline has been made for this conditions. Here, the relationship between hydrogen concentration and failure loading has been found. The existence of some critical hydrogen concentration, which causes the significant loss of local fracture resistance of material, was also shown.

© 2008 International Association for Hydrogen Energy. Published by Elsevier Ltd. All rights reserved.

## 1. Introduction

The European gas pipelines network plays very important role for national economies as well as global. This importance will permanently increase with prospective plans of introducing of European hydrogen energy infrastructure [1,2] and the possible use of existing pipeline networks for transportation of natural gas and hydrogen mixtures.

Within the European project NATURALHY, 39 European partners have combined their efforts to assess the effects of the presence of hydrogen on the existing gas network. Key

issues are durability of pipeline material, integrity management, safety aspects, life cycle and socio-economic assessment and end-use. The work described in this paper was performed within the NATURALHY work package on ‘Durability of pipeline material’ [3].

The number of aspects related to the technical feasibility and economics of developing a hydrogen energy infrastructure are presented and discussed in literature [4,5].

From this reason, the safety, durability and integrity issues related to hydrogen/natural gas mixtures in the existing natural gas system become actual and important. First of all,

\* Corresponding author. Tel.: +33387315277; fax: +33387315303.

E-mail address: [pluvina@univ-metz.fr](mailto:pluvina@univ-metz.fr) (G. Pluvinage).

0360-3199/\$ – see front matter © 2008 International Association for Hydrogen Energy. Published by Elsevier Ltd. All rights reserved.  
doi:10.1016/j.ijhydene.2008.09.020

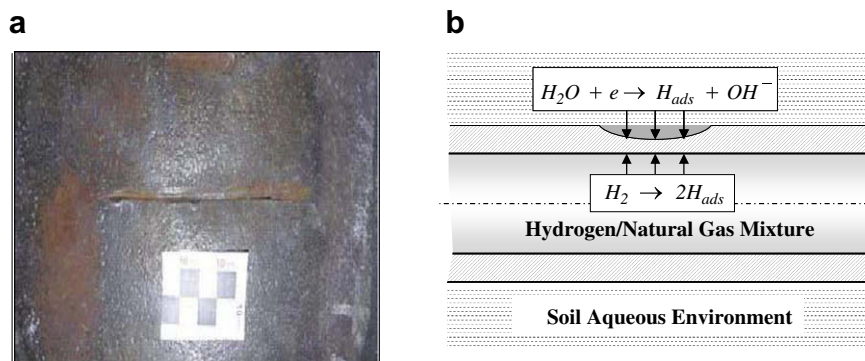

**Fig. 1 – Sample of defected pipe with gauge (a) and schematic presentation of possible ways of hydrogen influence on local strength of pipeline (b).**

there is a potential problem of so-called “hydrogen embrittlement” of pipeline material - the effects of transported hydrogen on material mechanical properties [6].

Moreover, the specific long-term exploitation of pipelines promotes the hydrogenating of steel. The external environmental conditions cause free corroding processes, where hydrogen can evaluate on metal surface as result of cathodic counterpart of the anodic dissolution reaction. This fact has been proved by several studies [7–9]. Also under in-service condition when a cathodic protection system is in place, hydrogen charging of pipeline steels is possible too [9,10]. As result there is the problem of structural integrity of aging buried pipelines having cathodic protection [10].

The state of reliability and integrity problems can be characterised by the recent data of European Gas pipeline Incident data Group (EGIG) [11]. The EGIG has maintained and expanded the European Gas pipeline incident database, which related to steel pipelines with design pressure >15 bar, excluding associated equipment (e.g. valves, compressors). The statistics of incidents collected in the database (more than 122,000 km of pipelines every year) gives reliable failure frequencies. It has been found that the failure frequencies were decreasing over the past 5 years, although they recently tend to stabilise on value about 0.17–0.19 incidents per 1000 km per year. The major cause of incidents remains external interference (50% of all incidents), followed by construction defects/material failures (17%) and corrosion (15%).

External interference incidents are characterised by potentially severe consequences: leaks and ruptures. In majority, these types of incidents are caused by initial damaging of the pipe external surface as result of third party interference e.g. by scratches and gouges and also pitting corrosion. Such defects can be considered as typical stress concentrators and consequently the privileged sites where the further damaging and failure processes occur. Here, it should

be noted that environmental effects on localised stressed volumes of material are principally different from the effects on the bulk of material [12]. Therefore, the knowledge about hydrogenating ability of bulk of metal as well as localised volumes is needed for reliable assessment of pipeline for transportation of hydrogen/natural gas mixture.

In this paper the steel API X52 was studied, as it is the most used in existing European gas pipelines network [11]. The two possible cases of hydrogen influence on pipeline metal were considered (Fig. 1), namely: gaseous hydrogen at an internal pressure in the pipe and electrochemically generated hydrogen on the external pipe surface from soil aqueous environment.

The burst tests of externally notched pipes under pressure of hydrogen and natural gas (methane) were carried out after the pipe has been exposed to an assigned constant “holding” pressure. The fracture surfaces were examined and comparative assessment of local fracture mechanism at notch bottom under the presence of hydrogen and methane has been done.

The sensitivity to hydrogenating of given steel in deoxygenated, near-neutral pH NS4 solution under soft cathodic polarisation was studied and the assessment of local strength at notches in pipeline has been performed for this conditions. Here, the relationship between hydrogen concentration and failure loading has been found. The existence of a critical hydrogen concentration level, which causes the significant loss of local fracture resistance of material, was also shown.

## 2. Object of study

The object of study was specimens of steel API X52, which were machined from real pipes. The chemical composition of steel and its mechanical properties in air are correspondingly given in Tables 1 and 2.

**Table 1 – Chemical composition of steel (wt%)**

C	Mn	Si	P	S	Al	Nb	Cu	Cr	Ni	V	Ti
0.08	1.06	0.26	0.019	0.003	0.039	0.041	0.018	0.02	0.019	0.054	0.003

**Table 2 – Mechanical properties of steel in air**

$\sigma_U$ , MPa	$\sigma_Y$ , MPa	Elongation, %
528	410	30.2

### 3. Effect of gaseous hydrogen: burst test of notched pipes under internal pressure

#### 3.1. Specimen and sequence of burst test

The longitudinally notched pipes with steel API X52 by diameter  $D = 219$  mm and wall thickness  $t = 6.1$  mm were the object of study (Fig. 2a). They were tested for burst under internal pressure of the hydrogen/natural gas mixture according to the test sequence, which is presented in Fig. 2b. Environmental test conditions: 100% of dry referenced natural gas (methane) and 100% of pure dry hydrogen and free oxygen (less than 1 ppm vol. residual oxygen).

#### 3.2. Testing equipment

For realisation of the given test programme a dedicated cell was designed and manufactured and also the automatic system for pressure control and test operating according to the assigned sequence was developed [13].

Generally, a test cell consists of three cylindrical shells: tube-specimen, external cylinder and internal cylinder. Two lids put down the tube-specimen and external cylinder. The special ring seals provide the compression. The external cylinder ( $d = 375$  mm) is needed as a protective housing. The function of the axially aligned internal cylinder ( $d = 165$  mm) is to reduce the hydrogen (or hydrogen/natural gas mixture) bulk volume within testing tube. This is necessary because the safety requirements during test procedure. The main objective of the designed cell is creating an additional space, which is filled by inert gas (argon) for avoiding an emergency situation if leakage of hydrogen/natural gas mixture at the pipe burst occurs. The general view of the designed test cell is given in Fig. 3. Here, for pictorial presentation the protective housing is removed. The automatic system for pressure control and test operating according to the assigned sequence is presented in Fig. 4.



**Fig. 3 – General view of designed testing equipment (protective housing is removed).**

Tests were carried out in special equipped laboratory with two separate spaces. First room is used for personnel and operating/controlling means. Second room is intrinsically safe space, where the testing stand is located. Gas-cylinders with hydrogen, natural gas, hydrogen/natural gas mixture and argon are boxed outside of the building. Stainless steel gas pipelines are used (internal diameter  $d = 6$  mm, wall thickness  $t = 2$  mm). Before test, all pipelines and cavities of testing cell, cut-off valve and pressure transmitters are purged with argon. The laboratory satisfies the safety requirements for working in hazardous gaseous environments. The automatic testing system provides the following capabilities:

- Gas pressure transmission in the cavity of testing pipe under assigned rate  $dp/dT$ .
- Keeping an assigned internal pressure in testing pipe constant during given time  $T$ .

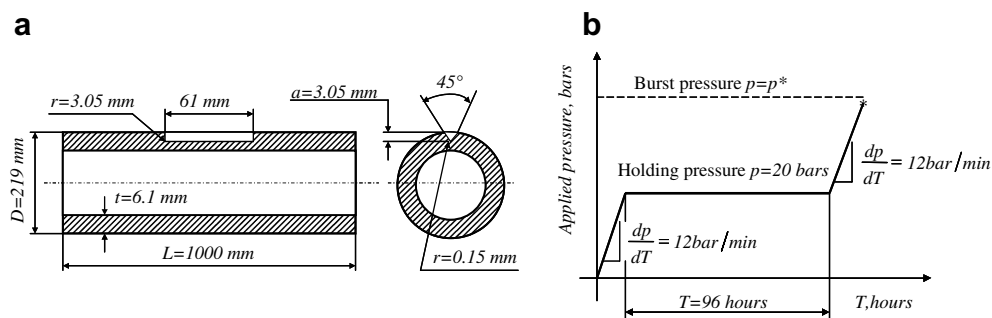

**Fig. 2 – Specimen geometry (a) and sequence of burst test procedure (b).**

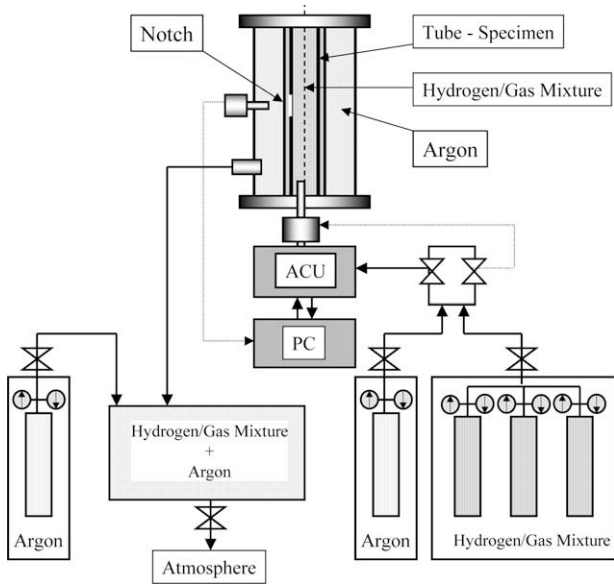

**Fig. 4 – General scheme of automatic testing system.**

- Loading of the test pipe by internal pressure under given rate  $dp/dt_{up}$  to tube burst  $p = p^*$ .
- Permanent registration of internal pressure  $p = \phi(T)$  in the tube-specimen during whole period of test.
- Visualisation of function  $p = \phi(T)$  in real time on the PC monitor for each stage of test.
- Registration and determining of the burst pressure  $p = p^*$ .
- Permanent registration of pressure on the external tube-specimen surface (space in testing cell that filled by argon) during whole period of test.
- Venting of the test cell (hydrogen/gas mixture + argon) after the tests is finished.
- Safety valve and outlet of the gaseous mixture to atmosphere.

### 3.3. Burst tests results and discussion

Burst tests of the given pipes with outer notch of assigned form and size and under pressure of hydrogen and methane were carried out (Fig. 5). Test results showed that burst pressure for test in methane is equal  $p_{max} = 118$  bar and burst pressure for test in hydrogen is equal  $p_{max} = 122$  bar. Therefore, there is no gaseous hydrogen effect on the strength of notched pipes for considered testing conditions.

However, the observation of pipes after burst tests showed differences of the pipe's residual distortion at notch area (see Fig. 6) between the two tests. For test in hydrogen the residual deformation of tube and notch opening is bigger than for the test in methane. This fact indicates a possible difference in fracture mechanisms.

Therefore the fracture surfaces were subjected to scanning electron microscopy (SEM) for determination of the initial points of fracture and also for checking of eventual fracture surface modification under influence of hydrogen. The SEM was concentrated on the following [13]:

- Examination of the inner surface at the edge of fractured notch
- Examination of the notch bottom with the aim to determine the fracture initiation sites
- Examination of the fracture surfaces with the aim of assessment their modification under hydrogen action

It has been found for both tests (in hydrogen and in methane) that the inner surface at the edge of fractured notch is characterised by a mesh of surface cracks (see Fig. 7). The comparison shows that for the case of hydrogen surface cracks the density is higher and their length is smaller (Fig. 7a) then for test in methane (Fig. 7b). Examination of the notch bottom showed that for both cases, the fracture is actually originated at the centre of the notch ( $\pm 1...2$  mm). The

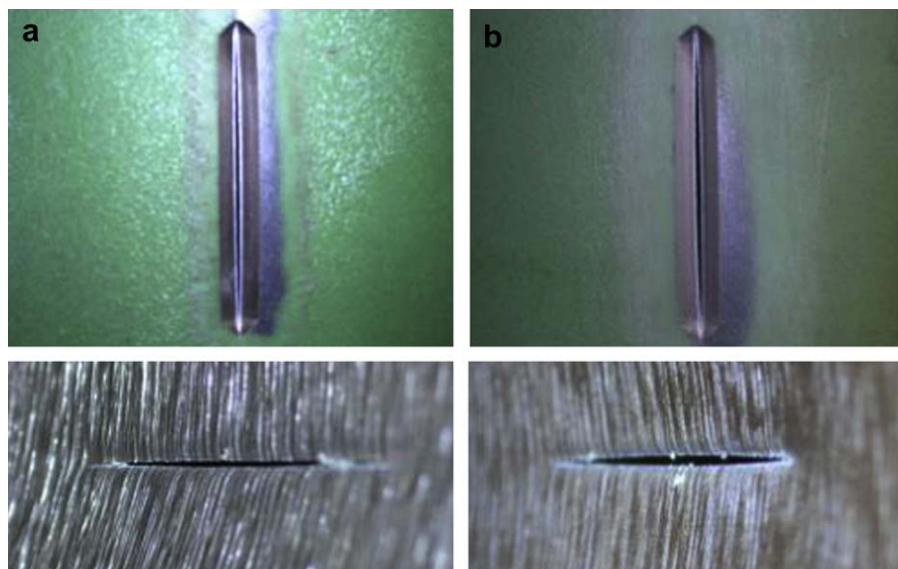

**Fig. 5 – View of outer and rear surfaces of tubes at notch area after burst test: (a) test in pure methane: burst pressure  $p_{max} = 118$  bar; (b) test in pure hydrogen: burst pressure  $p_{max} = 122$  bar.**

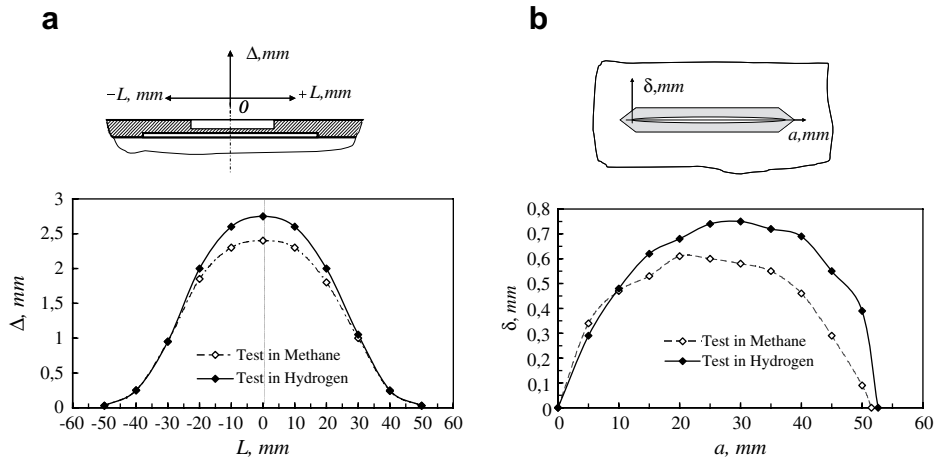

Fig. 6 – Comparison of the residual deformation (a) and the notch opening; (b) of tubes after burst test in methane and hydrogen.

mechanism of fracture initiation is developing from microcracks at the notch bottom (Fig. 8).

In general, it can be concluded that the fracture surface consists of two parts. First part is a surface created by microcracks growing from notch bottom and second part is the final failure, which is effected by shear mechanisms. This second part prevails at the inner surface of the tube along the notch and it may be considered as the final tough fracture (Fig. 9). There is the difference between fracture initiation from notch bottom for methane and hydrogen conditions. For tests in methane the tough low bulge forming was observed along the whole notch. It resulted from a sequence of increments (Fig. 10).

For the test in hydrogen the following picture was observed. There is alternation of the brittle and tough sites of fracture character (Fig. 11). The depth of this behaviour does not exceed a distance of about 50  $\mu\text{m}$  from the notch bottom. After that, the fracture is affected by dimple tough mechanisms as for test in methane.

Thus finally it may be concluded that fracture in methane is affected by a dimpled shear mechanism. Presence of hydrogen gives the mix-mode mechanism where the sites of dimple tough fracture and like terrace sites of brittle fracture exist simultaneously.

#### 4. Sensitivity of steel to electrochemical hydrogenating and hydrogen effect on local strength at notches

##### 4.1. Specimens

For the fracture tests the special “Roman tile” [14] specimens were used (Fig. 12), which were machined from a pipe with diameter  $D = 610$  mm and wall thickness  $t = 11$  mm. The specimens were notched for modelling of the longitudinal external defects under operating internal pressure (Fig. 13).

##### 4.2. Test conditions and electrochemical background

The study was conducted in special soil solution NS4 with  $\text{pH} = 6.7$  [15]. The chemical composition of this environment is given in Table 3.

In these conditions i.e., in deoxygenated, near-neutral pH solution, hydrogen atoms are generated on the steel surface by the electrochemical reduction of water molecules [7,8]:

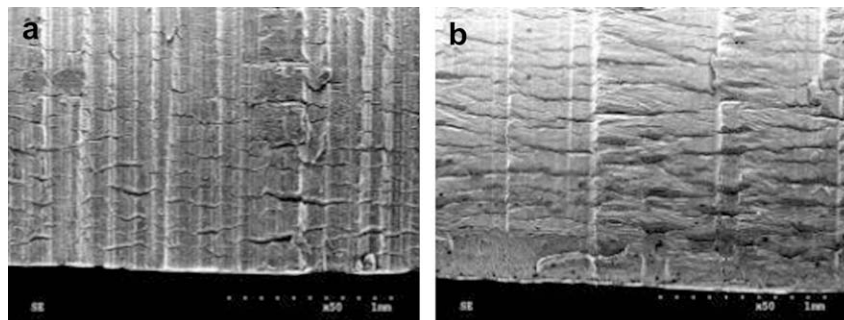

Fig. 7 – The surface cracks mesh at the edge of fractured notch: (a) test in hydrogen; (b) test in methane.

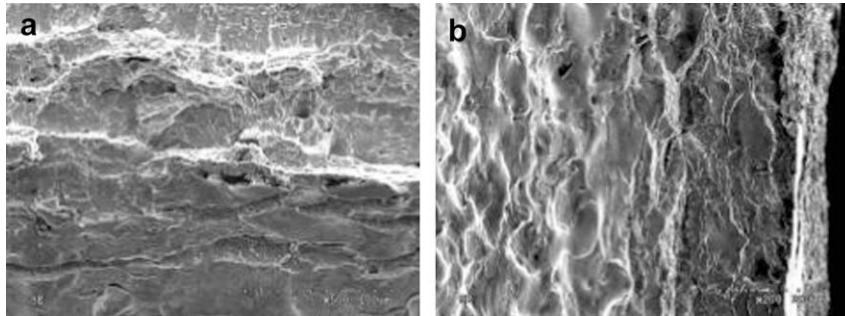

Fig. 8 – Microcracks at the notch bottom as source of fracture initiation: (a) test in hydrogen; (b) test in methane.

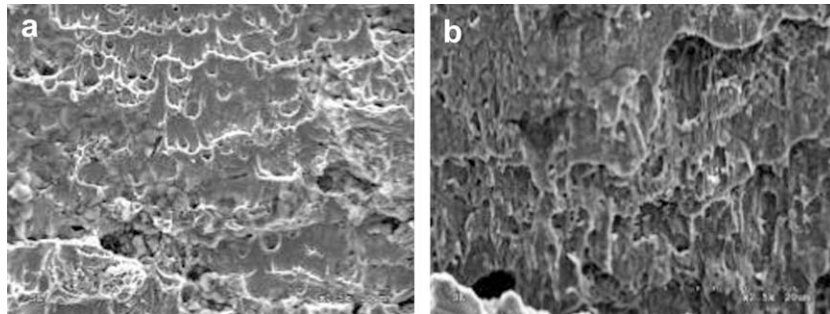

Fig. 9 – Fracture character at the inner surface of tube: (a) test in hydrogen; (b) test in methane.

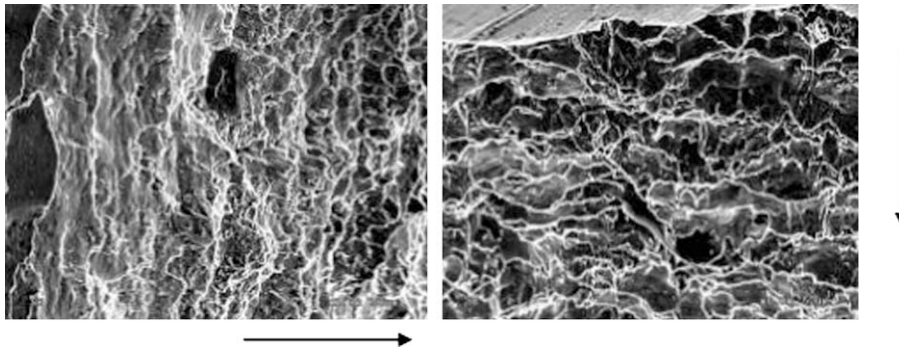

Fig. 10 – Fracture character from notch bottom for test in methane. Arrows indicate the fracture direction.

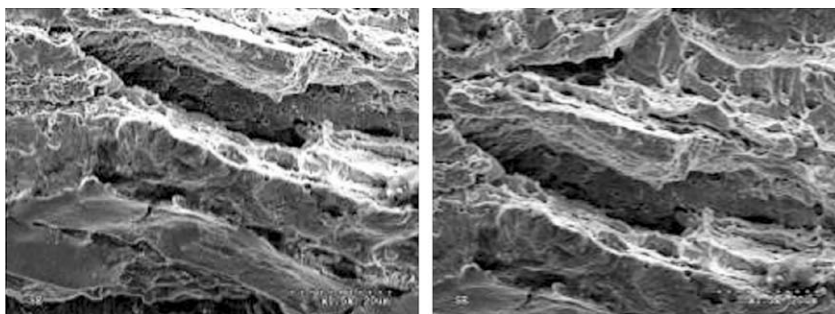

Fig. 11 – Fracture character from notch bottom for test in hydrogen.

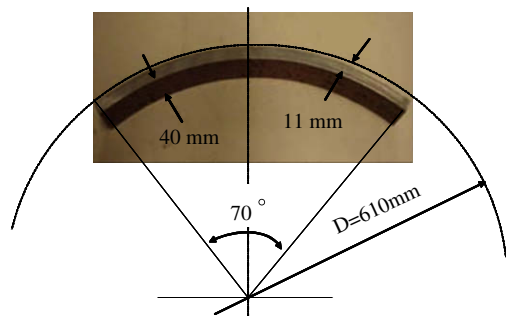

Fig. 12 – “Roman tile” specimen.

The adsorbed hydrogen atoms can subsequently combined to  $H_2$  molecules by the chemical reaction:



or the electrochemical reaction:



or can be absorbed by the steel:



Here it should be noted that [7,8] the absorbed hydrogen atom concentration under the cathodic polarisation depends on the hydrogen atom recombination mechanisms. When the chemical reaction (2) dominates the hydrogen atom recombination, the applied cathodic polarisation enhances the generation of hydrogen atoms and thus the amount of hydrogen atoms penetrating into the steel. The absorbed hydrogen atom concentration will increase continuously with the cathodic polarisation potential. In the case of electrochemical reaction (3) dominating the hydrogen atom recombination, the cathodic polarisation promotes the generation of hydrogen atoms through reaction (1), and simultaneously, enhances the hydrogen atom recombination through reaction (3). Thus, the role of cathodic polarisation is to generate hydrogen atoms and also to recombine hydrogen atoms.

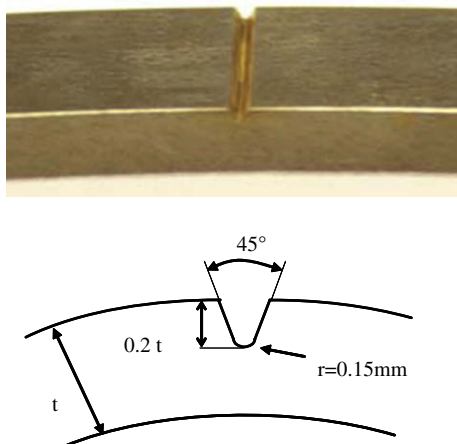

Fig. 13 – Notch geometry.

Table 3 – Chemical composition of NS4 solution (gram/litre) [10]

NaHCO <sub>3</sub>	KCl	CaCl <sub>2</sub>	MgCl <sub>2</sub> ·H <sub>2</sub> O
0.483	0.120	0.137	0.131

#### 4.3. Procedure of specimens hydrogen charging

The prevailing number of reported studies [16–19] was conducted while using cathodic charging of hydrogen under high density of polarisation current. Such charging is not truly representative of the hydrogen entry conditions in real operating pipelines, where there is the situation of freely corroding system [20]. This fact was pointed out in work [9].

To account for the fact that a steady state condition of hydrogen charging cannot be imposed nor obtained in a freely corroding situation, the following procedure has been applied in the presented study. The specimens were hydrogen charged at some constant potential of polarisation  $E_p = \text{const}$ , which is slightly more negative than the free corrosion potential for given steel:  $E_{cath} = -1000 \text{ mV(SCE)}$  and  $E_{corr} = -800 \text{ mV(SCE)}$ . For this experimental procedure the Potentiostat VMP [21] has been used.

Before testing, the specimens were coated by special dielectric isolation, excepting the small area at the notch (Fig. 14). The size of auxiliary (counter) electrode was  $20 \times 40 \text{ mm}$ . In this case its square is significantly larger than the working electrode area, which to be polarised. The specimens were immersed into the cell with special NS4 solution and exposed to a constant potential of polarisation  $E_{cath} = \text{const}$ . The surface of the auxiliary electrode was parallel to the notch plane at a constant distance  $h$ . The mutual location of working (specimen) and auxiliary (counter) electrodes is given in Fig. 14. During the hydrogen-charging process, the specimens were loaded. The level of load was defined as the gross hoop stress  $\sigma_{gross}$ , which corresponds of the internal pressure in pipe under exploitation  $p_{exp} = 70 \text{ bar}$ .

The hydrogen-charging process was controlled by registration of the cathodic polarisation current  $I_{cath}(\tau)$ . The total quantity of evaluated hydrogen on metal surface during time of exposition  $\tau_{exp}$  can be assessed as:

$$Q_H^{ev} = \int_0^{\tau_{exp}} I_{cath}(\tau) d\tau \text{ under } E_{cath} = \text{const}. \quad (5)$$

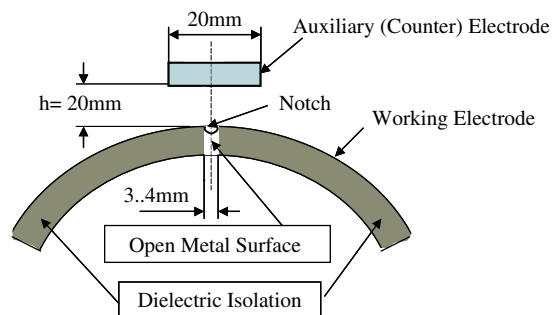
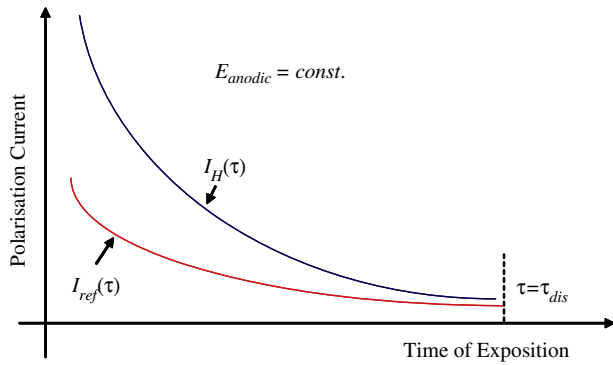

Fig. 14 – Mutual location of working electrode (specimen) and auxiliary (counter) electrode.





**Fig. 15 – Schematic view of hydrogen discharging process under anodic polarisation.**

#### 4.4. Determination of hydrogen concentration in metal

Hydrogen concentration in metal has been determined using a hydrogen discharging process under anodic polarisation with using of hydrogen electrochemical oxidation method proposed in work [22]. Here the standard three-electrode electrochemical cell has been used.

The hydrogen discharging of the specimen was carried out in 0.2 M NaOH (pH = 12.4) solution under anodic polarisation  $E_{anodic} = +168$  mV(SCE) during some defined time  $\tau_{dis}$  (see Fig. 15). The total quantity of absorbed hydrogen by metal can be defined as:

$$Q_H^{abs} = \int_0^{\tau_{dis}} [I_H(\tau) - I_{ref}(\tau)] d\tau \text{ under } E_{anodic} = \text{const.} \quad (6)$$

where  $I_H(\tau)$  is the anodic polarisation current for the hydrogen charged specimen and  $I_{ref}(\tau)$  is the anodic polarisation current for the specimen without hydrogen (reference curve). Calculation of the hydrogen concentration was performed according to formula:

$$C_H = \frac{Q_H^{abs}}{zFv} \quad (7)$$

Here  $z$  is the number of electrons used in the reaction;  $F$  is the Faraday constant;  $v$  is the effective volume of the specimen.

#### 4.5. Procedure of fracture toughness tests

After assigned exposure to hydrogenating conditions, all specimens were tested to failure under an increasing static loading, according to a 3-point bending scheme. An INSTRON test machine was used with a constant rate of displacement of grips  $d\Delta/d\tau = 0.02$  mm/s.

The “load – displacement” diagram and acoustic emission (AE) signals were simultaneously registered by PC during the tests. The start of fracture process at notch has been defined by an acoustic emission method [23]. The general scheme of tests is given in Fig. 16.

#### 4.6. Results and discussion

Process of hydrogen charging of pipeline steels at the given conditions of cathodic polarisation was characterised by

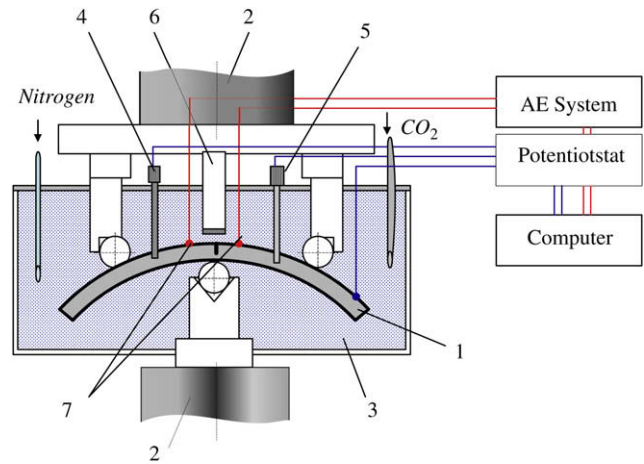

**Fig. 16 – Schematic view of testing equipment for fracture toughness measurement of hydrogen charged specimen: 1 – “Roman tile” specimen; 2 – loading device of testing machine; 3 – corrosion cell with NS4 solution; 4 – pH electrode; 5 – reference calomel electrode; 6 – auxiliary electrode; 7 – acoustic emission sensors.**

following parameters: hydrogen concentration in metal  $C_H$ ; total quantity of evaluated  $Q_{ev}$  and absorbed  $Q_{abs}$  hydrogen; averaged meaning of cathodic current density  $i_c$  and coefficient of efficiency of hydrogen permeation in metal  $k = Q_{abs}/Q_{ev}$ . The numerical values of these parameters are given in Table 4, respectively for unloaded and stressed metal.

Comparative assessment of hydrogen generation process on the metal surface and hydrogen permeation in metal for unloaded and stressed specimens showed an intensifying of both processes by applied stress. However, it can be concluded that the efficiency of hydrogen absorption in metal is quite low and depends on the time of exposition. Under  $\tau \geq 20$  h there is a monotonic decreasing trend for parameter  $k = Q_{abs}/Q_{ev}$  up to level  $k = 0.0013-0.0031$  (Fig. 17a). Generally, applied stress increases the hydrogen concentration in metal

**Table 4 – Data for determining of hydrogen concentration in pipeline steel API X52**

$\tau$ , h	$Q_H^{ev}$ , mA s	$i_c$ , mA/cm <sup>2</sup>	$\tau_{dis} = 1$ h		$k = Q_H^{abs}/Q_H^{ev}$
			$Q_H^{abs}$ , mA s	$C_H$ , 10 <sup>6</sup> mol/cm <sup>3</sup>	
Unloaded metal					
1	297.59	0.129	4.18	0.169	0.0140
3	636.23	0.092	9.85	0.399	0.0155
15	989.55	0.029	18.43	0.746	0.0186
66	5148.3	0.038	22.11	0.895	0.0043
148	5371.3	0.0157	15.51	0.628	0.0029
168	12443.3	0.0364	16.75	0.678	0.0013
Stressed metal					
46	57360	0.226	362.4	2.224	0.0063
101	168798	0.240	1216.5	5.924	0.0072
118	147522	0.524	458.6	2.814	0.0031
167.3	178564	0.463	–	–	–

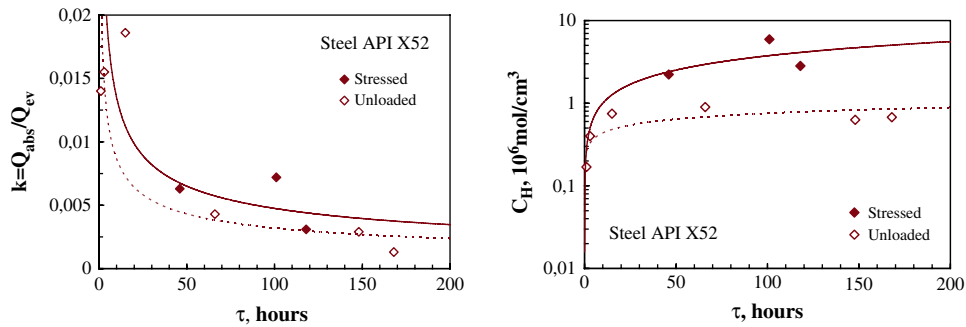

**Fig. 17 – Influence of applied stress on efficiency of hydrogen permeation in metal (a) and hydrogen concentration (b) in steel API X52.**

(Fig. 17b). After  $\tau \geq 100$  h the hydrogen concentration in stressed metal can be more than five times higher than the concentration in unloaded metal.

Based on experimental results, the increasing of hydrogen concentration in metal versus time of exposition of specimens in the hydrogenating conditions can be described by power relation:

$$C_H = A10^{-6}\tau^m [\text{mol}/\text{cm}^3]. \quad (8)$$

where  $A$  and  $m$  are constants (Table 5).

The study of local strength of notched specimens in presence of hydrogen resulted in the dependencies of total work of the local fracture  $U_t$  emanating from the notch:

$$U_t = U_e + U_p. \quad (9)$$

where  $U_e$  and  $U_p$  are elastic and plastic components. The scheme of determination of parameters  $U_t$ ,  $U_e$  and  $U_p$  is presented in Fig. 18.

The data for different time of exposition of specimens in hydrogenating conditions are given in Table 6. Here the hydrogen concentration  $C_H$  in metal was calculated by use of the analytical relation (8).

The main observation based on these results (Figs. 19 and 20) is the existence of some critical time of exposition and as a consequence – some critical hydrogen concentration  $C_H$ , when the essential decreasing of fracture toughness value is observed. For assessment of contribution of elastic and plastic components in total work of local fracture  $U_t$ , the following parameters were used:

$$r_e = \frac{U_e}{U_t} \quad \text{and} \quad r_p = \frac{U_p}{U_t}. \quad (10)$$

The dependencies of ratio  $U_e/U_t$  and  $U_p/U_t$  versus hydrogen concentration in metal show (Fig. 21) that the critical concentration exists in a region where the plastic component of fracture energy is decreasing with simultaneous increasing

of elastic component. Under given testing conditions for steel X52 the value of critical hydrogen concentration is about  $C_H \geq 4.3 \times 10^{-6} \text{ mol}/\text{cm}^3$  (Fig. 21). Here it should be noted that, in general, the diagram “work of local fracture - hydrogen concentration” could be a function of many factors, especially a radius of the notch tip. Therefore, the critical hydrogen concentration may be variable and depends on specificity of hydrogen interaction with local elasoplastic zone at the notch tip. The received curve  $U_t = F(C_H)$  can be used for assessment to hydrogen embrittlement of pipelines with steel API X52 under assigned testing conditions, i.e.: size of pipe and as result - geometry of specimen; notch radius, rate of loading and mode of hydrogen charging.

It should be stated that definition “critical concentration” is often used in studies of problems of hydrogen in metals and alloys [6,24–26]. Although in different works this term has different physical sense. For example, according to work [24], hydrogen treatment below the “critical” content was found to cause the substantial rearrangement of dislocations and decohesion of grain boundaries and in overcritical condition, the formation of micro crevices at the grain and phase boundaries has occurred. Others authors use this definition under developing of local fracture criteria [6,25]. In this study the term “critical concentration” defines the concentration level at the

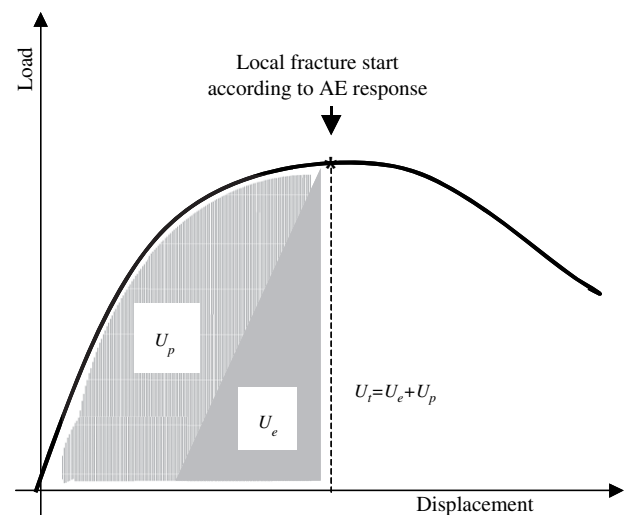

**Fig. 18 – Scheme of local fracture work determining.**

**Table 5 – Meanings of constants in formula (8)**

Test conditions	$A$	$m$
Unloaded metal	0.253	0.24
Stressed metal	0.300	0.57

**Table 6 – Data of fracture toughness tests of notched Roman tile specimens in presence of hydrogen**

$\tau$ , h	$U_t$ , N m	$U_e$ , N m	$U_p$ , N m	$U_e/U_t$	$U_p/U_t$	$C_H$ , $10^6$ mol/cm <sup>3</sup> formula (8)
46	32.12	12.91	19.21	0.402	0.598	2.660
101	26.57	11.12	15.43	0.418	0.581	4.165
118	15.53	10.85	4.68	0.699	0.301	4.551
167.3	10.47	6.57	3.90	0.627	0.372	5.553

time of critical loss of local strength of the material at the notch in the presence of hydrogen. The received data can be considered as a basis for further calculation with the aim of fracture risk assessment of defected pipelines. It may be performed according to the modified SINTAP procedure for the case of a notch, proposed in work [27], where a notch-based failure assessment diagram (NFAD) is developed.

At the end, it may be noted that the presented study is limited by a case of fracture toughness of notched specimen that are used as models of the mechanical defects like scratches or dents. It is evident that for deeper understanding of hydrogen contribution in durability of pipelines under real operating conditions, the corrosion and corrosion fatigue studies are required. The hydrogen may also affect the early stages of fatigue damage accumulation on the surface [28], especially when there is a gradient of hydrogen concentration at near-surface layer and bulk of material [29]. The problem of fatigue crack propagation accelerated by hydrogen is also important, because sometimes the pipeline leak occurs as result of subcritical crack growth [30].

## 5. Conclusions

The two possible cases of hydrogen influence on pipeline with steel API X52 were studied: gaseous hydrogen under internal

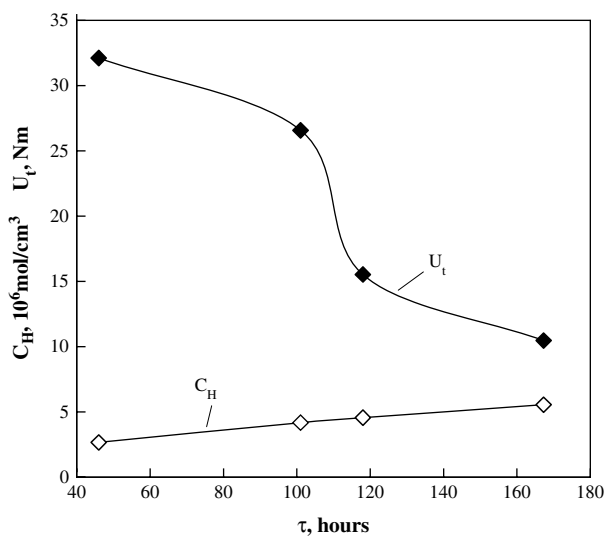

**Fig. 19 – Total work of local fracture  $U_t$  emanating from notch and hydrogen concentration in metal as function of time of exposition of specimens in hydrogenating conditions.**

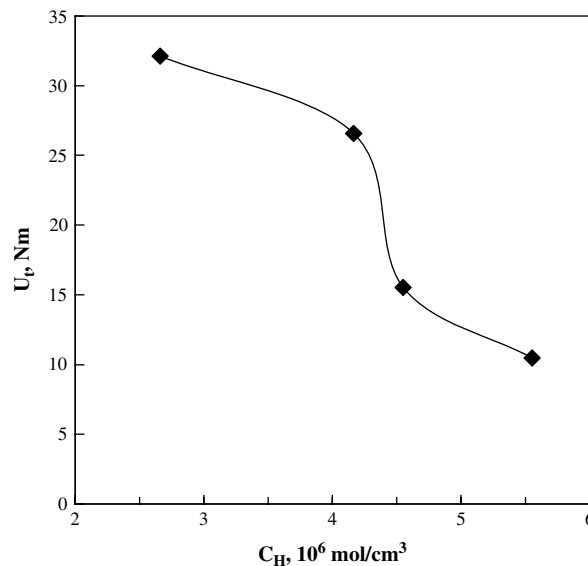
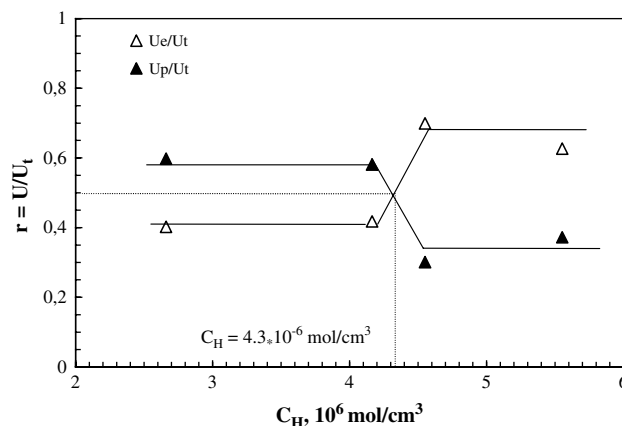

**Fig. 20 – Dependence of parameter  $U_t$  on hydrogen concentration  $C_H$ .**

pressure in the pipe and electrochemically generated hydrogen on external pipe surface from soil aqueous environment.

The burst tests of externally notched pipes under pressure of hydrogen and natural gas (methane) showed that there is no gaseous hydrogen effect on the strength of notched pipes for considered testing conditions. However, it has been found that even assigned condition (relatively low holding pressure of 20 bar and ambient temperature) the hydrogen is able to penetrate into near surface layers of metal and to change the mechanism of local fracture at the notch. Further continuation of work is required to assess the possible critical situations under different combinations of hydrogen holding pressure and time of exposition.

The studies of sensitivity of steel to electrochemical hydrogenating and hydrogen effect on local strength at notches have led to the following conclusions.



**Fig. 21 – Ratio  $U_e/U_t$  and  $U_p/U_t$  versus hydrogen concentration in metal.**

The steel API X52 demonstrates the sensitivity to hydrogenating in deoxygenated, near-neutral pH NS4 solution under “soft” cathodic polarisation. The efficiency of hydrogen permeation in metal is quite low and depends on time of exposition. It can be stated that under  $\tau \geq 20$  h there is the tendency of monotonic decreasing of parameter  $k = Q_{\text{abs}}/Q_{\text{ev}}$  up to level  $k = 0.0013\text{--}0.0031$ .

Applied stress, which equivalent to gross hoop stress in pipe wall under operating internal pressure 70 bars, significantly accelerates the hydrogen charging of steel. The difference between hydrogen concentrations in stressed metal can exceed more than five times the hydrogen concentration in unloaded metal.

For steel X52 a critical hydrogen concentration level exists, which causes the significant loss of local fracture resistance of material. This value might be considered as an important parameter for reliability assessment of exploited pipelines.

For assessment of local strength at notches in presence of hydrogen the diagram “work of local fracture - hydrogen concentration” is effective and it can be used for assessment to hydrogen embrittlement of pipelines with steel API X52 under assigned testing conditions.

## Acknowledgements

Presented study was partly performed within the frame of the European project NATYRALHY (EC Contract No. SES6/2004/502661). I. Dmytrakh would like to thank to Ecole Nationale d'Ingenieurs de Metz (ENIM) and Universite Paul Verlaine Metz for the opportunity to conduct this research.

## REFERENCES

- [1] Fernandes TRC, Chen F, and Da Graça Carvalho M, “HySociety” in support of European hydrogen projects and EC policy. *International Journal of Hydrogen Energy* 2005;30: 239–45.
- [2] Mulder G, Hetland J, Lenaers G. Towards a sustainable hydrogen economy: hydrogen pathways and infrastructure. *International Journal of Hydrogen Energy* 2007;32(10–11): 1324–31.
- [3] NaturalHy Project. Available from: <<http://www.naturalhy.net>>.
- [4] Wietschel M, Hasenauer U, de Groot A. Development of European hydrogen infrastructure scenarios - CO<sub>2</sub> reduction potential and infrastructure investment. *Energy Policy* 2006; 34(11):1284–98.
- [5] Yurum, editor. *Hydrogen energy systems: production and utilisation of hydrogen and future aspects*. The Netherlands: Kluwer Academic Publisher; 1995. p. 352.
- [6] Hanneken JW. *Hydrogen in metals and other materials: a comprehensive reference to books, bibliographies, workshops and conferences*. *International Journal of Hydrogen Energy* 1999;24(10):1005–26.
- [7] Cheng YF, Niu L. Mechanism for hydrogen evolution reaction on pipeline steel in near-neutral pH solution. *Electrochemistry Communications* 2007;9:558–62.
- [8] Cheng YF. Fundamentals of hydrogen evolution reaction and its implications on near-neutral pH stress corrosion cracking of pipelines. *Electrochimica Acta* 2007;52:2661–7.
- [9] Dey S, Mandhyan AK, Sondhi SK, Chattoraj I. Hydrogen entry into pipeline steel under freely corroding conditions in two corroding media. *Corrosion Science* 2006;48:2676–88.
- [10] Shipilov SA, May IL. Structural integrity of aging buried pipelines having cathodic protection. *Engineering Failure Analysis* 2006;13:1159–76.
- [11] European Gas pipeline Incident data Group (EGIG). Available from: <<http://www.egig.nl>>.
- [12] Dmytrakh IM. On corrosion fatigue initiation from notches and the local corrosion fracture approaches. In: Pluvinaige G, Gjonaj M, editors. *NATO science series: II. mathematics, physics and chemistry “Notch Effects in Fatigue and Fracture”*. Dordrecht/Boston/London: Kluwer Academic Publishers; 2001. p. 331–46.
- [13] Burst tests on pipes under pressure of mixture of hydrogen and natural gas. Final report on subcontract no 1401-2005 of NATURALHY-project (contract no SES6/2004/502661). Karpenko Physico-Mechanical Institute of National Academy of Sciences of Ukraine, Lviv, Ukraine; 2006.
- [14] Adib-Ramezani H, Jeong J, Pluvinaige G. Structural integrity evaluation of X52 gas pipes subjected to external corrosion defects using the SINTAP procedure. *International Journal of Pressure Vessels and Piping* 2006;83:420–32.
- [15] Mao SX, Li M. Mechanics and thermodynamics on the stress and hydrogen interaction in crack tip stress corrosion: experiment and theory. *Journal of the Mechanics and Physics of Solids* 1998;46(6):1125–37.
- [16] Hardie D, Charles EA, Lopez AH. Hydrogen embrittlement of high strength pipeline steels. *Corrosion Science* 2006;48: 4378–85.
- [17] Torres-Islas A, Salinas-Bravo VM, Albarran JL, Gonzalez-Rodriguez JG. Effect of hydrogen on the mechanical properties of X-70 pipeline steel in diluted NaHCO<sub>3</sub> solutions at different heat treatments. *International Journal of Hydrogen Energy* 2005;30:1317–22.
- [18] Zhang T, Chu WY, Gao KW, Qiao LJ. Study of correlation between hydrogen-induced stress and hydrogen embrittlement. *Materials Science and Engineering A* 2003; 347:291–9.
- [19] Cheng YF. Analysis of electrochemical hydrogen permeation through X-65 pipeline steel and its implications on pipeline stress corrosion cracking. *International Journal of Hydrogen Energy* 2007;32:1269–76.
- [20] Li MC, Cheng YF. Mechanistic investigation of hydrogen-enhanced anodic dissolution of X-70 pipe steel and its implication on near-neutral pH SCC of pipelines. *Electrochimica Acta* 2007;52:8111–7.
- [21] Potentiostat VMP. Manual. Princeton Applied Research; 2004.
- [22] Yan M, Weng Y. Study on hydrogen absorption of pipeline steel under cathodic charging. *Corrosion Science* 2006;48: 432–44.
- [23] Vallen-Systeme acoustic emission. Manual. Germany: Vallen-Systeme GmbH; 2006.
- [24] Lunarska E, Ososkov Y, Jagodzinsky Y. Correlation between critical hydrogen concentration and hydrogen damage of pipeline steel. *International Journal of Hydrogen Energy* 1997;22(2/3):279–84.
- [25] Lufrano J, Sofronis P. Enhanced hydrogen concentrations ahead of rounded notches and cracks – competition between plastic strain and hydrostatic stress. *Acta Metalurgica* 1998; 46(5):1519–26.
- [26] Venegas V, Caley F, Gonzalez JL, Baudin T, Hallen JM, Penelle R. EBSD study of hydrogen-induced cracking in API-5L-X46 pipeline steel. *Scripta Materialia* 2005;52: 147–52.

- [27] Pluvinage G. General approaches of pipeline defect assessment. In: Pluvinage G, Elwany MH, editors. NATO science for peace and security series "Safety, Reliability and Risks Assessments with Water, Oil and Gas Pipelines". Springer; 2008. p. 1-22.
- [28] Akid R, Dmytrakh IM, Gonzalez-Sanchez J. Fatigue damage accumulation: the role of corrosion on the early stages of crack growth. *Corrosion Engineering, Science and Technology* 2006;41(4):328-35.
- [29] Olden V, Thaulow C, Johnsen R, Ostby E. Cohesive zone modelling of hydrogen-induced stress cracking in 25% Cr duplex stainless steel. *Scripta Materialia* 2007;57: 615-8.
- [30] Dmytrakh I. Corrosion fatigue cracking and failure risk assessment of pipelines. In: Pluvinage G, Elwany MH, editors. NATO science for peace and security series "Safety, Reliability and Risks Assessments with Water, Oil and Gas Pipelines". Springer; 2008. p. 99-113.