



**HAL**  
open science

# Aspects fonctionnels et structuraux des systèmes thiorédoxine et glutarédoxine de peuplier et de leurs enzymes cibles, les peroxyrédoxines et les méthionine sulfoxyde réductases de type A

Nicolas Rouhier

► **To cite this version:**

Nicolas Rouhier. Aspects fonctionnels et structuraux des systèmes thiorédoxine et glutarédoxine de peuplier et de leurs enzymes cibles, les peroxyrédoxines et les méthionine sulfoxyde réductases de type A. Biologie végétale. Université Henri Poincaré - Nancy 1, 2003. Français. NNT : 2003NAN10104 . tel-01748118

**HAL Id: tel-01748118**

**<https://hal.univ-lorraine.fr/tel-01748118v1>**

Submitted on 29 Mar 2018

**HAL** is a multi-disciplinary open access archive for the deposit and dissemination of scientific research documents, whether they are published or not. The documents may come from teaching and research institutions in France or abroad, or from public or private research centers.

L'archive ouverte pluridisciplinaire **HAL**, est destinée au dépôt et à la diffusion de documents scientifiques de niveau recherche, publiés ou non, émanant des établissements d'enseignement et de recherche français ou étrangers, des laboratoires publics ou privés.



## AVERTISSEMENT

Ce document est le fruit d'un long travail approuvé par le jury de soutenance et mis à disposition de l'ensemble de la communauté universitaire élargie.

Il est soumis à la propriété intellectuelle de l'auteur. Ceci implique une obligation de citation et de référencement lors de l'utilisation de ce document.

D'autre part, toute contrefaçon, plagiat, reproduction illicite encourt une poursuite pénale.

Contact : [ddoc-theses-contact@univ-lorraine.fr](mailto:ddoc-theses-contact@univ-lorraine.fr)

## LIENS

Code de la Propriété Intellectuelle. articles L 122. 4

Code de la Propriété Intellectuelle. articles L 335.2- L 335.10

[http://www.cfcopies.com/V2/leg/leg\\_droi.php](http://www.cfcopies.com/V2/leg/leg_droi.php)

<http://www.culture.gouv.fr/culture/infos-pratiques/droits/protection.htm>

UFR Sciences et Techniques Biologiques  
E.D. Ressources, Procédés, Produits et Environnement  
UMR 1136 UHP-INRA Interaction Arbres Microorganismes



# Thèse

*présentée pour l'obtention du grade de*

Docteur de l'Université Henri Poincaré, Nancy I  
en Biologie Forestière

*par* **Nicolas Rouhier**

**Aspects fonctionnels et structuraux des systèmes  
thiorédoxine et glutarédoxine de peuplier  
et de leurs enzymes cibles,  
les peroxyrédoxines et les méthionine sulfoxyde  
réductases de type A**

Soutenu le 4 juillet 2003

Composition du jury :

Président du jury : **Bob Buchanan**

Rapporteurs : **Pierre Gadal**  
**Pascal Rey**

Examineurs : **Yves Meyer**  
**Guy Branlant**

Directeur de thèse : **Jean-Pierre Jacquot**

Professeur, Université de Berkeley, USA

Professeur, Université Paris -Sud, Orsay

Ingénieur/Chercheur CEA, Cadarache

Directeur de Recherche CNRS, Perpignan

Professeur, Université Henri Poincaré, Nancy

I

Professeur, Université Henri Poincaré, Nancy

I

<b>Abréviations</b> .....	<b>1</b>
<b>Introduction</b> .....	<b>3</b>
1. Les molécules réductrices non enzymatiques.....	7
1.1 Le glutathion.....	8
1.2 L'ascorbate.....	9
2. Les différents systèmes réducteurs, thiorédoxine et glutarédoxine.....	10
<b>Article 1</b> : Redox control by dithiol-disulfide exchange in plants: I. The chloroplastic systems. ....	15
<b>Article 2</b> : Redox control by dithiol-disulfide exchange in plants: II. The cytosolic and mitochondrial systems. ....	28
<b>Article 3</b> : Thioredoxins and related proteins in photosynthetic organisms: molecular basis for thiol dependent regulation. ....	38
3. Les protéines cibles et enzymes utilisant les glutarédoxines et thiorédoxines comme donneur de pouvoir réducteur.....	44
3.1 Les peroxyrédoxines.....	47
<b>Article 4</b> : Plant peroxiredoxins : alternative hydroperoxide scavenging enzymes.....	47
3.2 Les méthionine sulfoxyde réductases.....	61
3.2.1 Les MsrA.....	61
3.2.1.1 Les différentes familles.....	61
3.2.1.2 La structure .....	65
3.2.1.3 Le mécanisme catalytique.....	66
3.2.2 Les MsrB.....	67
3.2.2.1 Les différentes familles.....	67
3.2.2.2 La structure.....	70
3.2.2.3 Le mécanisme catalytique.....	70
3.3 La réduction des MetSO libres.....	72
3.4 Expression et fonctions des méthionine sulfoxyde réductases.....	72
3.5 Les protéines de fusion.....	74
3.6 Les méthionine sulfoxyde réductases végétales.....	75
4. Mon travail de thèse .....	79
<b>Résultats</b> .....	<b>81</b>
<i>Chapitre I : Les systèmes réducteurs</i> .....	81
<b>Article 5</b> : Isolation and characterization of an extended thioredoxin h from poplar. ....	82
<b>Article 6</b> : Identification and characterization of a third thioredoxin h in poplar.....	90

<b>Article 7</b> : Enhancement of poplar glutaredoxin expression by optimization of the cDNA sequence. ....	98
<b>Article 8</b> : Exploring the active site of plant glutaredoxin by site-directed mutagenesis. ....	107
<b>Article 9</b> : Characterization of the redox properties of poplar glutaredoxin. ....	113
<b>Article 10</b> : Crystallization and preliminary X ray data of poplar glutaredoxin. ....	122
<i>Chapitre II : Les protéines cibles</i> .....	127
<b>Article 11</b> : Isolation and characterization of a new peroxiredoxin from poplar sieve tubes that uses either glutaredoxin or thioredoxin as a proton donor.....	128
<b>Article 12</b> : Glutaredoxin-dependent peroxiredoxin from poplar: protein-protein interaction and catalytic mechanism. ....	140
<b>Article 13</b> : Crystallization and preliminary X-ray data of a bifunctional peroxiredoxin from poplar. ....	148
<b>Article 14</b> : Active site mutagenesis and phospholipid hydroperoxide reductase activity of type II poplar peroxiredoxin.....	151
<b>Article 15</b> : Further characterization of plant peroxiredoxins : molecular characterization of chloroplastic poplar peroxiredoxin Q and its involvement in the pathogenic response. ....	175
<b>Article 16</b> : Functional and structural aspects of poplar type A methionine sulfoxide reductase. ....	208
<b>Discussion</b> .....	<b>245</b>
1. <i>Le rôle des espèces réactives chez les plantes</i> .....	245
2. <i>Intervention des Trx, Grx, Prx et MsrA dans la lutte antioxydante</i> .....	247
2.1 <i>Spécificité ou redondance des systèmes réducteurs ?</i> ....	247
2.2 <i>Les connexions entre les systèmes Trx et Grx</i> .....	250
2.3 <i>Les mécanismes de réduction catalytiques des Prx et des MsrA</i> .....	251
3. <i>Expression et localisation de ces protéines</i> .....	254
4. <i>Les structures tridimensionnelles</i> .....	256
<b>Perspectives</b> .....	<b>259</b>
<b>Références</b> .....	<b>261</b>

ADN : acide désoxyribonucléique  
ADNc : ADN complémentaire  
Ahp : alkyl hydroperoxyde réductase  
Apx : ascorbate peroxydase  
ARNt : acide ribonucléique de transfert  
Asc : ascorbate  
BCP : bacterioferritin comigratory protein  
CDSP : chloroplastic drought-induced protein  
CUOOH : cumene hydroperoxide  
DHA : déhydroascorbate  
DHAR : déhydroascorbate réductase  
DTT : dithiothreitol  
EDTA : ethylene diamine tetra acetic acid  
EST : expressed sequence tag  
FBPase : fructose 1, 6 bisphosphatase  
GFP : green fluorescent protein  
Gpx : glutathion peroxydase  
GR : glutathion réductase  
Grx : glutarédoxine  
GSH : glutathion réduit  
GSSG : glutathion oxydé  
HED : hydroxyéthyl disulfide  
H<sub>2</sub>O<sub>2</sub> : peroxyde d'hydrogène  
kDa : kilodalton  
mBBr : monobromobimane  
MDH à NADP : malate déshydrogénase à NADP  
MDHA : monodéhydroascorbate  
MDHAR : monodéhydroascorbate réductase  
Met : méthionine  
MetSO : méthionine sulfoxyde  
Msr : méthionine sulfoxyde réductase  
MsrA : méthionine sulfoxyde réductase de type A  
MsrB : méthionine sulfoxyde réductase de type B  
NAD(P)H : nicotinamide adénine dinucléotide (phosphate) réduit

NTR : NADPH thiorédoxine réductase

PAGE : polyacrylamide gel electrophoresis

PAPS : 3'-phosphoadénosine 5'-phosphosulfate

PCOOH : phosphatidylcholine hydroperoxide

PCR : polymerase chain reaction

PDI : protéine disulfide isomérase

PHGpx : phospholipide hydroperoxyde glutathion peroxydase

PICOT-HD : Protein Kinase C Interacting Cousin of Thioredoxin Homology Domain

Prx : peroxyrédoxine

QTL : quantitative trait loci

RMN : résonance magnétique nucléaire

RNR : ribonucléotide réductase

RNS : reactive nitrogen species

ROS : reactive oxygen species

SDS : sodium dodecyl sulfate

SOD : superoxyde dismutase

SOH : acide sulfénique

t-BOOH : tertiary butyl hydroperoxide

TR : thiorédoxine réductase

Tris : Tris [hydroxyméthyl] aminoéthane

Trx : thiorédoxine

UV : ultra violet

WT : wild type

# *Introduction*



Dans un métabolisme cellulaire basal, le fonctionnement des chaînes de transfert d'électrons et de certaines oxydases génère la formation d'espèces réactives oxygénées (ROS) ou nitrées (RNS) (Figure 1).

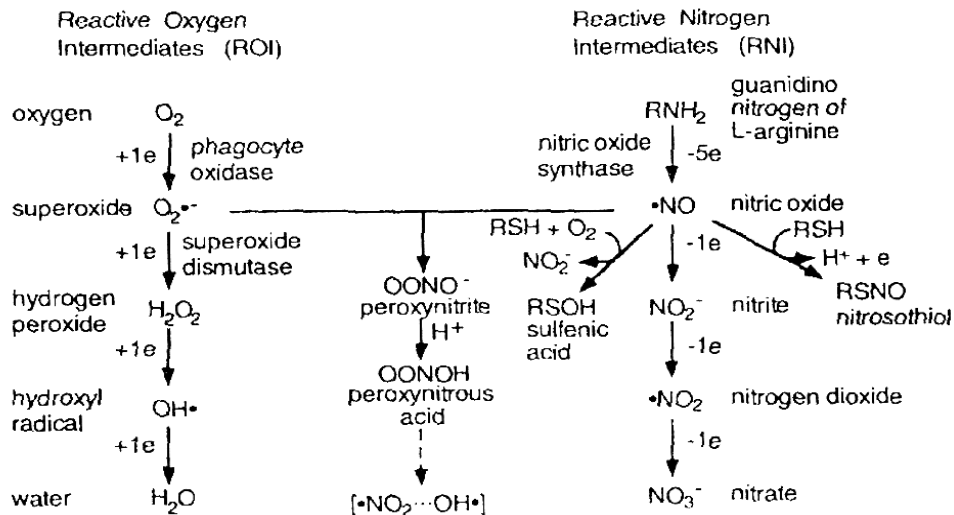

Figure 1 : Voies de production des espèces oxygénées et nitrées réactives (d'après Nathan & Shiloh, 2000).

Les concentrations de ces produits sont plus élevées lors de stress biotiques ou abiotiques. A faible concentration, ces espèces radicalaires semblent être impliquées dans les mécanismes de signalisation cellulaire, alors que de fortes concentrations induisent un stress oxydatif qui va engendrer notamment des dommages au niveau des macromolécules telles que les lipides, les acides nucléiques et les protéines (Figures 2, 3 et 4) (Halliwell & Gutteridge, 1990 ; Beckman *et al.*, 1997 ; Berlett *et al.*, 1997 ; Neill *et al.*, 2002 ; Kohler *et al.*, 2003).

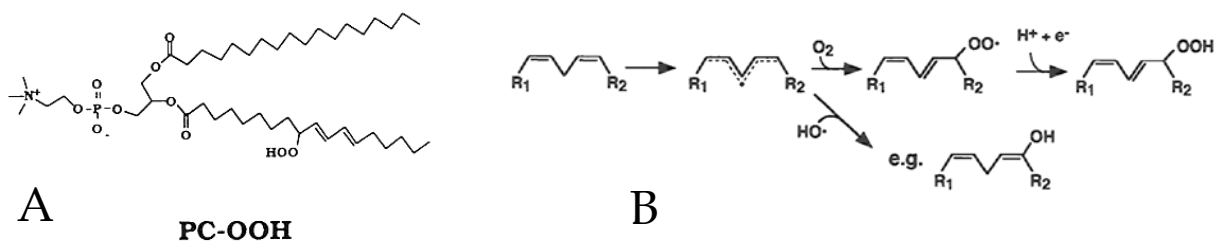

Figure 2 : Phosphatidylcholine hydroperoxyde (PCOOH) (A) et oxydation des acides gras en acides gras hydroperoxydes (B) (d'après Baier & Dietz, 1999c ; Yamamoto, 2000).

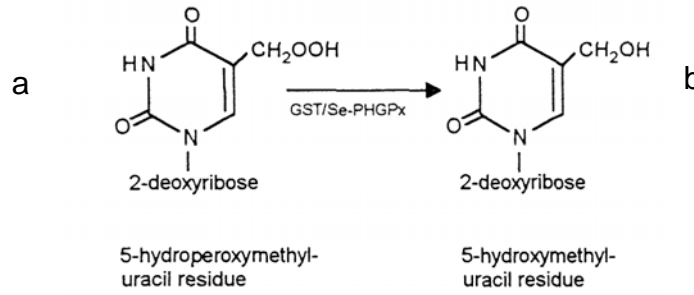

Figure 3 : **Réduction de la thymine hydroperoxyde en thymine** (d'après Bao *et al.*, 1997). Les thymines sont les nucléotides les plus touchés par les radicaux libres et sont transformées en thymine hydroperoxydes (a), qui pourront être réduites ensuite en thymines (b) par des phospholipide hydroperoxyde glutathion peroxydases (PHGpx) ou des glutathion S-transférases (GST).

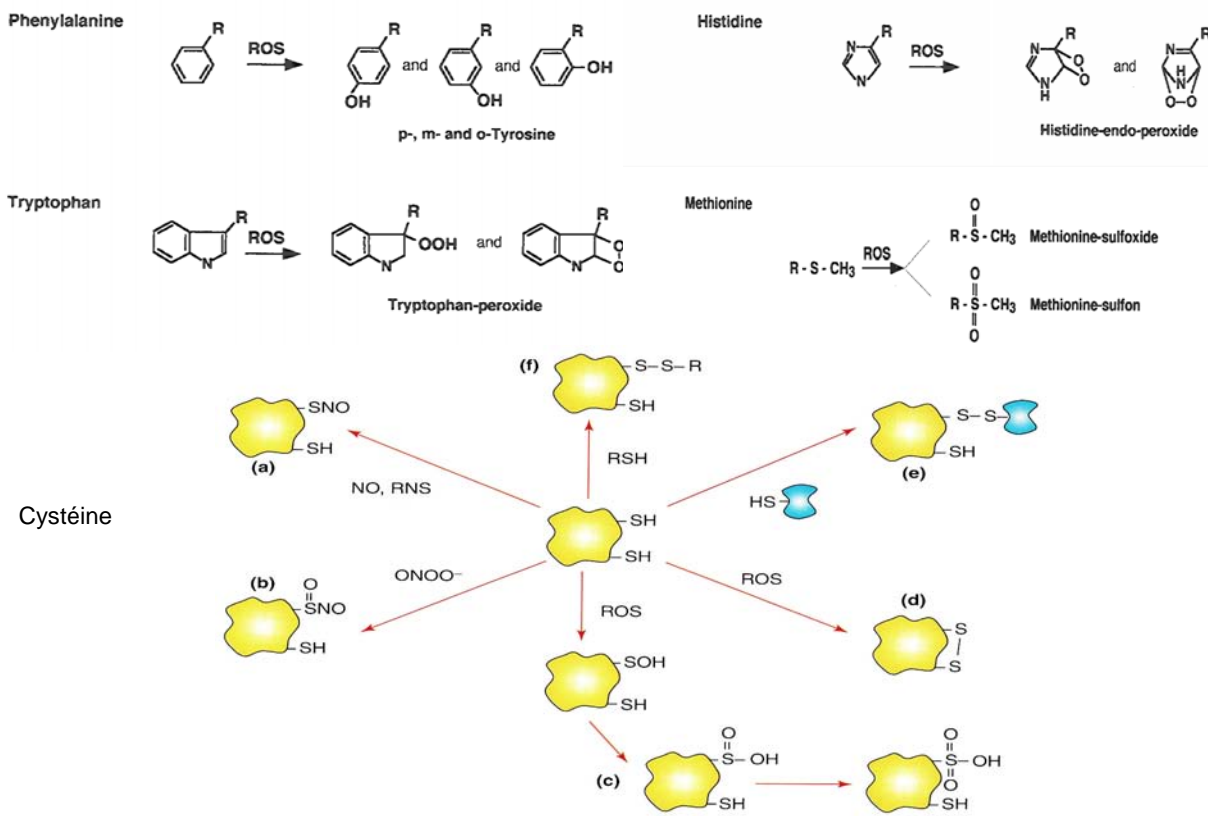

Figure 4 : **Etats d'oxydation de la phénylalanine, du tryptophane, de l'histidine, de la méthionine et de la cystéine** (d'après Baier & Dietz, 1999c ; Cooper *et al.*, 2002).

Tous les acides aminés sont sujets aux phénomènes d'oxydation par les ROS mais certains le sont plus particulièrement. Il s'agit des histidines, des tryptophanes, des phénylalanines, des cystéines et des méthionines (Figure 4). Les deux acides aminés soufrés, cystéine et méthionine, sont les plus sensibles et les systèmes permettant de restaurer leur structure initiale sont très documentés. L'atome de soufre que renferment ces deux acides aminés peut présenter différents états d'oxydation. Le soufre de la méthionine peut ainsi se retrouver sous forme sulfoxyde ou sulfone et l'atome de soufre des cystéines peut être oxydé en des formes encore plus nombreuses (Figure 4) (Cooper *et al.*, 2002). Ainsi, outre la formation de ponts disulfures intramoléculaires (4d), les thiols des cystéines peuvent former des ponts disulfures intermoléculaires pour créer des homodimères ou des hétérodimères avec d'autres protéines (4f) mais aussi avec des petites molécules telles que le glutathion (4e). Les ROS vont également provoquer l'apparition d'acides sulféniques (SOH) (4c) qui pourront être réduits et d'acides sulfiniques (SO<sub>2</sub>H) (4c) et sulfoniques (SO<sub>3</sub>H) (4c) qui sont des modifications irréversibles. Par ailleurs, les espèces nitrées vont engendrer également des modifications. L'action du peroxy-nitrite va former des groupements nitrothiols (OSNO) (4b) par S-nitration, alors que l'oxyde nitrique va provoquer des phénomènes de S-nitrosylation et l'apparition de nitrosothiols (SNO) (4a).

Dans la plupart des protéines, les cystéines et les méthionines sont généralement présentes en faible quantité relativement aux autres acides aminés mais leur présence et leur intégrité sont néanmoins essentielles pour la structure et le fonctionnement de ces protéines. Les cystéines ont notamment la capacité de lier des métaux et de participer au centre actif de nombreuses enzymes et transporteurs d'électrons. Lors de la biosynthèse des protéines, les cystéines sont intégrées à l'état réduit et la formation des ponts disulfures n'est possible que lorsque les thiols présents dans la chaîne latérale sont suffisamment proches dans l'espace, généralement à des distances avoisinant 2Å. Les ponts disulfures ainsi constitués sont des éléments essentiels non seulement pour le maintien de la structure de certaines protéines, mais aussi quelquefois pour leur activité. Lorsqu'une association défavorable se produit, conduisant à un polypeptide incorrectement assemblé, les ponts disulfures doivent être isomérisés. Cette fonction est assurée au niveau du réticulum endoplasmique principalement par les protéines disulfide isomérases (PDI) chez les eucaryotes et par la protéine DsbC chez les procaryotes (Debarbieux &

Beckwith, 1999 ; Frand *et al.*, 2000 ; Collet *et al.*, 2002). Ces deux protéines de la famille des oxydoréductases réalisent ces isomérisations de ponts disulfures du fait de leur potentiel rédox élevé et de la nature de leur site actif (Figure 5). De manière générale, plus le potentiel rédox du site actif d'une protéine est bas, plus elle a des aptitudes réductrices (Chivers *et al.*, 1997 ; Mossner *et al.*, 1999).



Figure 5 : **Potentiel rédox des protéines de la famille des oxydoréductases** (d'après Aslund *et al.*, 1997).

Un autre phénomène essentiel pour le fonctionnement cellulaire est la réduction de ces ponts disulfures. En effet, leur formation dans le cytosol n'est qu'un état transitoire puisqu'un certain nombre de molécules enzymatiques et non enzymatiques ont pour fonction de maintenir l'environnement intracellulaire réduit. Ainsi, certaines protéines oscillent en permanence entre un état réduit et un état oxydé. Il est généralement admis que les protéines intracellulaires ne possèdent pas ou peu de ponts disulfures contrairement aux protéines extracellulaires.

Face aux diverses espèces oxydantes, la cellule dispose d'au moins deux stratégies de défense, soit détruire ces différentes entités oxydantes, soit réparer les dommages ou changements engendrés par ces molécules. De nombreuses enzymes, elles-même soumises à ces modifications, sont capables d'effectuer ces réactions de défense. Parmi celles-ci, certaines doivent être réduites pour agir. Il existe ainsi deux systèmes enzymatiques principaux à l'origine de la réduction des ponts disulfures dans les protéines, les systèmes thiorédoxine (Trx) et glutarédoxine (Grx). Ces protéines, qui appartiennent à la famille des oxydoréductases, fonctionnent principalement par des échanges dithiols-disulfures avec leurs partenaires. Outre ces deux systèmes enzymatiques, un certain nombre d'autres molécules ont un rôle crucial à jouer. Il s'agit essentiellement du glutathion (GSH) et

de l'ascorbate, mais aussi de l' $\alpha$ -tocophérol par exemple. La synthèse bibliographique qui suit, articulée autour de quatre articles de revue résumant l'essentiel des données acquises chez les végétaux, a pour but de décrire non seulement le fonctionnement de ces systèmes réducteurs (Trx et Grx) mais aussi leur capacité à régénérer deux types d'enzymes cibles impliquées dans la lutte anti-oxydante. Ce sont des peroxydases Trx ou Grx dépendantes appelées peroxyrédoxines (Prx), qui réduisent le peroxyde d'hydrogène et différents alkyles ou lipides hydroperoxydes, et des méthionine sulfoxyde réductases (Msr) qui ont pour fonction essentielle de réduire des méthionine sulfoxydes (MetSO) en méthionine (Met).

Ce manuscrit décrira en priorité les informations fournies par les études sur les plantes, en incluant, lorsque les articles de synthèse sont devenus incomplets, les avancées récentes dans le domaine végétal. Mettant à profit le séquençage complet du génome d'*Arabidopsis thaliana*, les séquences végétales présentées pour décrire les différentes familles de protéines seront celles d'*A. thaliana*, trouvées dans la base de donnée MATDB (MIPS (Munich information center for protein sequences) *A*rabidopsis *t*haliana database), à l'adresse suivante : <http://mips.gsf.de/proj/thal/db/index.html>. Par ailleurs, les Msr végétales étant très peu caractérisées, les informations obtenues chez divers autres organismes seront principalement décrites.

### 1. Les molécules réductrices non enzymatiques

Ces molécules, à fort pouvoir anti-oxydant, telles que le GSH, l'acide ascorbique (vitamine C) ou l' $\alpha$ -tocophérol (vitamine E) agissent soit directement sur les espèces oxydantes, soit indirectement en activant un certain nombre d'enzymes aux propriétés anti-oxydantes (Noctor & Foyer, 1998). De plus, l'équilibre entre les états de réduction ou d'oxydation de ces molécules est gouverné par le cycle de régénération ascorbate-glutathion (Figure 6) (Asada, 1999).

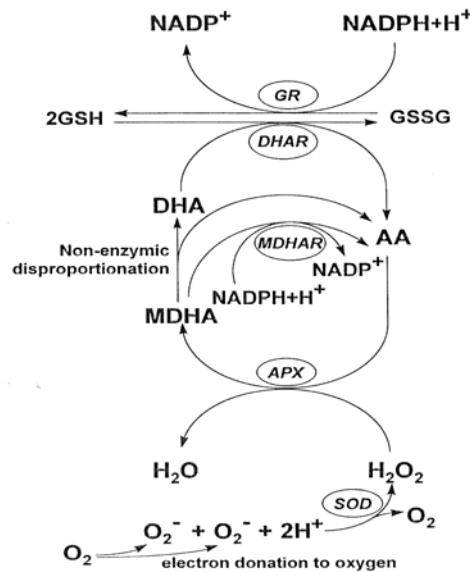

Figure 6 : **Cycle ascorbate glutathion** (Noctor & Foyer, 1998).

Les abréviations utilisées sont :

AA : ascorbate, APX : ascorbate peroxydase, DHA : déhydroascorbate, DHAR : déhydroascorbate réductase, GR : glutathion reductase, GSH : glutathion réduit, GSSG : glutathion oxydé, MDHA : monodéhydroascorbate, MDHAR : monodéhydroascorbate réductase, SOD : superoxyde dismutase.

### 1.1 Le glutathion

Le glutathion sous forme réduite (GSH) est un tripeptide, formé d'un résidu - glutamyl, couplé à un résidu cystéinyl, lui-même lié à un résidu glyciny (Figure 7). C'est la source majeure de thiols non protéique dans les cellules. Il est maintenu réduit par l'action d'une GR NADPH dépendante. La forme oxydée consiste en la liaison de deux molécules par un pont disulfure au niveau des cystéines. La concentration du GSH dans les chloroplastes est de l'ordre de 5 mM et il est très majoritairement sous forme réduite (90% en général) (Noctor & Foyer, 1998). Son action anti-oxydante se déroule à différents niveaux. Il peut réduire directement certaines espèces oxygénées réactives. De plus, il intervient dans la réduction enzymatique du déhydroascorbate (DHA) en ascorbate par la déhydroascorbate



peut également participer à la régénération du radical tocophérol en  $\alpha$ -tocophérol (Padh, 1990). En effet, l' $\alpha$ -tocophérol peut agir soit sur les anions superoxydes ou radicaux hydroxyles, soit sur les lipides hydroperoxydes, se retrouvant ensuite transformé en un cation radicalaire (Liebler *et al.*, 1986). A la suite de son action, l'ascorbate est oxydé en un radical monodéhydroascorbate (MDHA) (Figure 8). La réaction entre deux radicaux MDHA aboutit à la formation d'un ascorbate et d'un DHA. Une enzyme NADPH dépendante, la MDHA réductase peut également effectuer cette réaction (Noctor & Foyer, 1998). Par ailleurs, une enzyme NADPH et GSH dépendante, la DHAR catalyse la réduction du DHA en ascorbate (Foyer & Mullineaux, 1998).

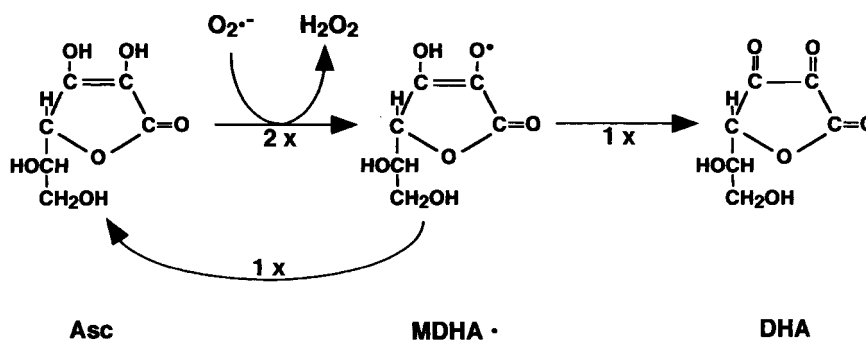

Figure 8 : **Etats d'oxydation de l'acide ascorbique.**

Sous l'action d'espèces oxygénées réactives, l'ascorbate (Asc) peut être oxydé en un radical monodéhydroascorbate (MDHA $\cdot$ ), lui-même pouvant être oxydé en DHA (Baier & Dietz, 1999).

## 2. Les différents systèmes réducteurs, thiorédoxine et glutarédoxine

De nombreuses isoformes des Trx et des Grx existent dans différents compartiments cellulaires. Le séquençage complet du génome d'*A. thaliana* indique qu'il existe au moins 26 gènes codant pour des Trx et 29 pour des Grx. Parmi les Trx, au moins 9 sont cytosoliques, 9 chloroplastiques, 2 mitochondriales et 2 monocystéiniques de localisation indéterminée (Tableau I) (pour revue sur la classification des Trx voir Meyer *et al.*, 2002). Parmi les Grx, 14 sont bicystéiniques et 15 monocystéiniques (Tableau I, Figure 9). Cette répartition partagée entre les 2 types d'isoformes s'explique par le fait que les Grx peuvent fonctionner en présence



de GSH selon un mode dithiol, de manière analogue aux Trx, ou selon un mode monothiol (Gravina & Mieyal, 1993). Par contre, très peu d'isoformes de Trx sont monocystéiniques car ces enzymes ne fonctionnent a priori qu'avec les deux cystéines du site actif. On peut s'interroger d'une part sur la fonction de ces Trx monocystéiniques et d'autre part sur l'intérêt d'une telle redondance entre les Trx et Grx pour les organismes. Un début de réponse sur la redondance entre les isoformes de Trx consiste à dire que les localisations de certaines isoformes sont différentes et que des spécificités de reconnaissance *in vivo* existent entre ces différents réducteurs et leurs cibles même si cette spécificité n'est pas toujours observable *in vitro* (Mouaheb *et al.*, 1998 ; Brehelin *et al.*, 2000 ; Santandrea *et al.*, 2002).

	<b>Numéros d'accension</b>	<b>Longueur</b>	<b>Localisation</b>	<b>Site actif</b>
Thiorédoxines h				
h1	At3g51030	114	cytosolique	WCGPC
h2	At5g39950	133	cytosolique	WCGPC
h3	At5g42980	118	cytosolique	WCPPC
h4	At1g19730	125	cytosolique	WCPPC
h5	At1g45145	118	cytosolique	WCPPC
h7	At1g59730	129	cytosolique	WCGPC
h8	At1g69880	148	cytosolique	WCGPC
h9	At3g08710	140	cytosolique	WCGPC
TDX	At3g17880	163	cytosolique	WCGPC
Thiorédoxines m				
m1	At1g03680	179	chloroplastique	WCGPC
m2	At4g03520	186	chloroplastique	WCGPC
m3	At2g15570	173	chloroplastique	WCGPC
m4	At3g15360	193	chloroplastique	WCGPC
Thiorédoxines f				
f1	At3g02730	178	chloroplastique	WCGPC
f2	At5g16400	185	chloroplastique	WCGPC
Thiorédoxines y				
y1	At1g76760	151	chloroplastique	WCGPC
y2	At1g43560	162	chloroplastique	WCGPC
Thiorédoxines o				
o1	At2g35010	194	mitochondriale	WCGPC
o2	At1g31020	159	mitochondriale	WCGPC
Thiorédoxine x	At1g50320	171	chloroplastique	WCGPC
Thiorédoxines type Liliium				
Liliium 1	At1g08570	245	cytosolique	GCGGC
Liliium 2	At4g26160	220	?	WCGSC
Liliium 3	At5g61440	234	?	GCGGC
Liliium 4	At2g33270	242	?	SCGGC

Thiorédoxines monocystéiniques					
CxxS1	At2g40790	178	cytosolique	WCLPS	
CxxS2	At1g11530	118	cytosolique	WCIPS	
Glutarédoxines bicystéiniques					
CxxC1	At5g63030	125	cytosolique	YCGYC	
CxxC2	At5g40370	111	cytosolique	YCPYC	
CxxC3	At1g77370	130	cytosolique	YCPYC	
CxxC4	At5g20500	135	cytosolique	YCPYC	
CxxC5	At4g28730	174	chloroplastique	WCSYC	
CxxC6	At4g33040	144	cytosolique	SCCMC	
CxxC7	At3g02000	136	cytosolique	TCCMC	
CxxC8	At5g14070	140	cytosolique	TCCMC	
CxxC9	At1g28480	137	cytosolique	GCCMC	
CxxC10	At5g11930	145	chloroplastique	SCCMC	
CxxC11	At3g62950	103	cytosolique	SCCMC	
CxxC12	At2g47870	103	cytosolique	SCCMC	
CxxC13	At2g47880	102	cytosolique	SCCLC	
CxxC14	At3g62960	102	cytosolique	SCCLC	
Glutarédoxines monocystéiniques					
CxxS1	At1g03020	102	cytosolique	SCCMS	
CxxS2	At5g18600	102	cytosolique	SCCMS	
CxxS3	At4g15700	102	cytosolique	SCCMS	
CxxS4	At4g15680	102	cytosolique	SCCMS	
CxxS5	At4g15690	102	cytosolique	SCCMS	
CxxS6	At3g62930	102	cytosolique	SCCMS	
CxxS7	At4g15670	102	cytosolique	SCCMS	
CxxS8	At4g15660	102	cytosolique	SCCMS	
CxxS9	At2g30540	102	cytosolique	SCCMS	
CxxS10	At3g21460	102	mitochondriale	TCCMS	
CxxS11	At1g06830	99	cytosolique	SCCLS	
CxxS12	At2g20270	179	chloroplastique	WCSYS	
CxxS13	At3g54900	173	chloroplastique	MCGFS	
CxxS14	At1g03850	150	chloroplastique	GCCLG	
CxxS15	At3g15660	169	mitochondriale	QCGFS	

Tableau I : **Les différentes isoformes de Trx et de Grx d'*A. thaliana*.**

Pour chaque séquence sont précisés le numéro d'accèsion, la longueur de la protéine en acides aminés, la localisation certaine ou présumée et enfin la séquence du site actif. Les données sur les Trx sont essentiellement issues de Meyer *et al.*, 2002 et Lemaire *et al.*, 2003. Les Trx y1 et y2 ont été appelées également Trx ch2-1 et ch2-2. Les localisations des Grx sont toutes prédites essentiellement à partir des programmes de prédiction suivants:

Target P (<http://www.cbs.dtu.dk/services/TargetP>)

Predotar (<http://www.inra.fr/predotar>)

Mitop (<http://www.mips.biochem.mpg.de/cgi-bin/proj/medgen/mitofilter>).

```

CxxC1 -----MGSMFSGNRMSKEEMEVVVKAKEIVS-AYPVVVFSK-----T
CxxC2 -----MAMQKAKEIVN-SESVVFSK-----T
CxxC3 -----MVDQSPRRVVVAALLLFVVLCDLSNSAGAANS-VSAFVQNAIL-SNKIVIFS-----S
CxxC4 -----MTMFRSISMVLLVALVTFISMVSSAASSPEADFVKKTI-SHKIVIFS-----S
CxxC5 MAVTAFNTLKLVSSSLDPISVSCSSYSFSLIYVGSPIKRLKQSCSVRAMTS---SSS-AASSSSSFGSRMEESIRKTVT-ENTVVIYSK-----T
CxxC6 -----MMQELGLQRFNSNDVVRDLT--P--P-----SQTSTSLSIDEEESTEAIRRLIS-EHPVIFSR-----S
CxxC7 -----MQYQTESWG--SYKMSSLGF-----GGLGMVADTG-LLRIEASLAS-ESAVVIFS-----S
CxxC8 -----MQYKTETRGSLSYNNNSKVM-----NNMNVFPSET-LAKIESMAA-ENAVVIFS-----S
CxxC9 -----MQGTISCARNYNTMTTGVGSLRPLSLKTQNGERVRMVE-ENAVIVIGR-----R
CxxC10 -----MRGLRNCSDAVTLDLTVHPPPPPLPPAPSTVSSSTASTSLSFDEEETSEKIGRLIS-EHPVIFTRF-----S
CxxC11 -----MERIRDLS--KKAAVIFTK-----S
CxxC12 -----MERVRDLAS-EKAAVIFTK-----S
CxxC13 -----MDKVMRMS--EKGVIIFTK-----S
CxxC14 -----MDKVMRMS--EKGVIIFTK-----S
CxxS1 -----MEKISNLE-DKPVVIFS-----T
CxxS2 -----MDMITKVM-ERPVIYSK-----S
CxxS3 -----MENLQKMIS-EKSVVIFS-----N
CxxS4 -----MDKLQKMIS-EKSVVIFS-----N
CxxS5 -----MENLQKMIS-EKSVVIFS-----N
CxxS6 -----MESVRLVE-DKPVVIFS-----S
CxxS7 -----MEKLQKMTS-EKSLVIFS-----N
CxxS8 -----MAASLSSRLIKGIANLKAVERSSRLTSASVYQNGMMRFSSSTVPSDSDTHDDFKPTQKVPDSDTSLKDIVENDVK-DNPVMIYMKGVPEP-----S
CxxS9 -----MDKVMRMS--EKGVIIFTK-----S
CxxS10 -----MDVVARLAS-QRAVVIFS-----S
CxxS11 -----MDKVMRMS--EKGVIIFTK-----S
CxxS12 MVAATVNLANMTWTSLSNPAISFMSLSGIRNLGMLPFRRLKPTVIGIASWPLRCSSVKAMSSSSSSSGSTLEETVKTTVA-ENPVVYSK-----T
CxxS13 ---MALRSVKTPTLITSVAVVSSVTKPHSIRFSLKPTSAIVVHNHQLSFYGSNLKLPKTKFRCSASALTPQLKDTLEKLVN-SEKVLVFMKTRDFP-----S
CxxS14 -----MQKAIRPYESPWTKTPVGNISIFLLKNEDKPSSSSSLSWLTSGSPKPTISINKRSSNLVVMENAVVVFAR-----R
CxxS15 -----MEKIQKMIS-EKSVVIFS-----N

CxxC1 YCGYQQRVKQLLTLQGLATFKVLELDEM-SDGGEIQSALSSEWTGQT-----TVPNVFIKGNHIGGCDRVMETNKQKLVPLLLEAGAIDANSSQL--
CxxC2 YCPYCVRVKELLQQLGAKFAVELDTE-SDGSQIQSGLAETGQR-----TVPNVFIGGNHIGGCDATSNLHKDGKLVPLLLEAGAIAGKTATTSA
CxxC3 YCPYCLRSKRIFSQLKEEFPVVELDQR-EDGDQIQYELLELVGRR-----TVPVFVNGKHIIGGSDDLGAALSEGQLQKLLAAS-----
CxxC4 YCPYCKKAKSVFRELQVYVVELDER-EDGWSIQTALGEIVGRR-----TVPVFINGKHLGGSDTVDAYESGELAKLLGVSNGKEAEL-----
CxxC5 WGSYCTEVKTLFKRLGVQPLVVELDQLGPGQPLQKVLERLTGQH-----TVPNVFCVKHIGGCTDTVKLNKRGDLEMLLAEANGKNGQS-----
CxxC6 SCCMCHVMKRLLATIGVIPTVIELD-D-HEVSSLPTALQDEYSGG-----VSVVGPPPAVFIGRECVGLESVALHLHSGQLVPLKVVQVWALW--
CxxC7 TCCMCHAVKGLFRGMGVSFAVHELDLH-PYGGDIQRALIRLLGCS--GSSSPGSLPVVFIGGKLVGAMDRVMASHINGSVPLLKDAGALWL-----
CxxC8 TCCMCHAIKRLFRGMGVSFAVHELDLL-PYGVIEHRALLRLLGCSGGATSPGALPVVFIGGKLVGAMDRVMASHINGSVPLLKDAGALWL-----
CxxC9 GCCMCHVVRLLLDLGLVNPVLEIDEE--REDEVLESELENIGVQG---GGGTVKLPAVYVGGRLFGGLDRVMATHISGELVPLIKVEVWALWL-----
CxxC10 SCCMCHVMKLLSTVGVHPTVIEID-D-GEIAYL-----AVEAAPVLFIGGTCVGGFESLVALHLSGQLIPRLEVEGALWA-----
CxxC11 SCCMCHSIKTLFYELGASPAIHELDKD-PEGREMERALRALGSSN---P---AVPAVFGGRYIGSAKDIISFHVDGSLKQMLKDAKAIWL-----
CxxC12 SCCMCHSIKTLFYELGASPAIHELDKD-PQGPDMERALFRVFGSN---P---AVPAVFGGRYVGSADKDIISFHVDGSLKQMLKASNAIWL-----
CxxC13 SCCLCYAVQILFRDLRVQPTIHEIDND-PDCREIEKALRLGCST-----AVPAVFGGKLVGSTNEVMSLHLSGSLVPLIKPYQSTILY-----
CxxC14 SCCLCYAVQILFRDLRVQPTIHEIDND-PDCREIEKALVRLGCAN-----AVPAVFGGKLVGSTNEVMSLHLSGSLVPLIKPYQSFHN-----
CxxS1 SCCMCHSIKSLISGYGANSTVYELDEM-SNGPEIERALVELGCKP-----TVPAVFIGQELVGGANQLMSLQVRNQLASLRRRAGAIWI-----
CxxS2 SCCMCHSIKTLFLDFGVPNTIYELDEI-SRGREIEQALRLGCSP-----AVPGVFIGGELVGGANQVMSLHLSGSLVPLIKPYQSFHN-----
CxxS3 SCCMCHSIKTLFLDFGVPNTIYELDEI-SRGKEIEHALAQLGCSP-----TVPVVFIGGQLVGGANQVMSLHLSGSLVPLIKPYQSFHN-----
CxxS4 SCCMCHSIKTLFLDFGVPNTIYELDEI-NRGKIEQALQALGCSP-----TVPVVFIGGQLVGGANQVMSLHLSGSLVPLIKPYQSFHN-----
CxxS5 SCCMCHSIKTLFLDFGVPNTIYELDEI-NIGREIEQALQALGCSP-----TVPVVFIGGQLVGGANQVMSLHLSGSLVPLIKPYQSFHN-----
CxxS6 SCCMCHSIKTLFLDFGVPNTIYELDEI-SNGQIEKALVQMGCKP-----SVPVAVFIGQFVGGANQVMTLQVKNQLAAMLRRRAGAIWV-----
CxxS7 SCCMCHSIKTLFLDFGVPNTIYELDEI-NRGKIEQALQALGCSP-----TVPVVFIGGQLVGGANQVMSLHLSGSLVPLIKPYQSFHN-----
CxxS8 QCGFSSLAVRVLQYVNPVNISSRNILED---QELKNAVKSFSHPW-----TFPQIFIKGEFIGGSDIILNMHKEGELEQKLDKDVSGNQD-----
CxxS9 SCCMCHSIKTLFLDFGVPNTIYELDEI-PECREIEKALMRLGCST-----PVPVAVFIGGKLVGSTNEVMSLHLSGSLVPLIKPYQSFHN-----
CxxS10 TCCMCHAIKRLFYEQGVSPAIVEIDQD-MYGDIEWALARLGCSP-----TVPAVFGGKLVGTANTVMTLHLNLSKILLKEAGALWL-----
CxxS11 SCCLCYAVQILFQDLGVPNPKIHEIDKD-PECREIEKALMRLGCST-----PVPVAVFIGGKLVGSTNEVMSLHLSGSLVPLIKPYQSFHN-----
CxxS12 WGSYSSQVKSFLKSLQVEPLVVELDQLGSEGSQVLEKITGQY-----TVPNVFIGGKHIGGCDTLQLHNKGELEAIIAEANGKNGQT-----
CxxS13 MCGFNTVQILKLNVPFEDVNILEN---EMLRQGLKEYSNWP-----TFPQYIIGGEFFGGCDITLFAFTGELQEEVEKAMCS-----
CxxS14 GCCLGHVAKRLLLTHGVNPVVEIGEE--DNNDYDNIIVSD--KE-----KLPMMYIGGKLVGGLENLMAAHINGDLVPTLRQAGALWL-----
CxxS15 SCCMCHSIKTLFLDFGVPNTIYELDEI-NRGKIEYALQALGCSP-----TVPVVFIGGQLVGGANQVMSLHLSGSLVPLIKPYQSFHN-----

```

**Figure 9 : Alignement de séquence des Grx d'*A. thaliana*.**

En gris clair, les acides aminés strictement conservés et notamment la première cystéine catalytique. En gris foncé, la deuxième cystéine du site actif des Grx bicystéiniques ou la sérine du site actif des Grx monocystéiniques. La séquence CxxS14 possède une glycine à la place de la sérine, mais possède par ailleurs toutes les caractéristiques d'une Grx.

Les trois articles de revue suivants traitent de façon non exhaustive des différents modes de réduction des Trx et Grx de plantes, de leurs structures et de leurs fonctions. Ces systèmes sont très bien caractérisés chez les organismes bactériens et animaux mais les connaissances acquises chez ces organismes ne seront pas détaillées dans ce manuscrit.

Article numéro 1 :**Jacquot JP, Rouhier N, Gelhaye E. (2002)***Redox control by dithiol-disulfide exchange in plants: I. The chloroplastic systems.***Ann. N. Y. Acad. Sci. 973:508-19.**

Cet article présente les voies de régulation rédox par échange dithiol-disulfure dans les chloroplastes. Il décrit la composition et le fonctionnement d'une chaîne de régulation appelée le système ferrédoxine-thiorédoxine qui comprend le transport photosynthétique d'électrons, et trois protéines solubles, la ferrédoxine, la ferrédoxine-thiorédoxine réductase, et les Trx. La structure de ces protéines et leur mode d'interaction sont détaillés. Le mécanisme enzymatique qui est impliqué dans ces régulations est basé sur des cascades d'échanges dithiol-disulfure dans lesquelles une protéine se trouve oxydée alors que le partenaire est réduit. Dans la deuxième partie de cet article sont détaillées les cibles moléculaires de ces systèmes de régulation chloroplastique. Une attention particulière est accordée aux enzymes pour lesquelles il existe à la fois des données biochimiques et structurales (NADP-MDH et FBPase). Il apparaît que la régulation rédox est apparue au cours de l'évolution et de l'avènement de la photosynthèse oxygénique. Les biocatalyseurs régulés ont été modifiés par addition ou insertion de séquences régulatrices de petite taille ou par intégration sélective de cystéines adaptées à créer des ponts disulfures. Après réduction, les enzymes cibles des Trx doivent subir une étape de changement conformationnel pour aboutir à une configuration active.

Par contre, aucune Grx chloroplastique n'a été caractérisée chez les végétaux jusqu'à présent, mais la GR et le GSH sont présents en grande quantité dans ce compartiment cellulaire et certaines séquences d'*A. thaliana* possèdent une extension N-terminale susceptible de diriger la protéine vers le chloroplaste (Tableau I).

# Redox Control by Dithiol–Disulfide Exchange in Plants

## I. The Chloroplastic Systems

JEAN-PIERRE JACQUOT,<sup>a</sup> NICOLAS ROUHIER, AND ERIC GELHAYE

*Interaction Arbres Microorganismes UA 1136 INRA UHP, Université Henri Poincaré, BP 230, 54505 Vandoeuvre Cedex, France*

**ABSTRACT:** In plants, the photons of light are absorbed at the level of the photosystems in the chloroplasts. The functioning of the photosynthetic electron transfer chain linked to this process is required to generate NADPH and ATP. In addition, the light signal promotes a regulatory cascade, situated in the stroma, that involves ferredoxin, ferredoxin-thioredoxin reductase, and thioredoxins. This redox-based signal transduction chain allows fine regulation of stromal enzymes and tight control of the photosynthetic process. The molecular properties and the functioning of this redox regulatory chain will be described in this review.

**KEYWORDS:** dithiol–disulfide exchange; ferredoxin; redox regulation; thioredoxin

### DISCOVERY OF REDOX CONTROL BY DISULFIDE REDUCTION

Based on the observations that di-chloro-methyl-urea (DCMU) inhibits and dithiothreitol mimicks the light-dependent regulation of chloroplast enzymes, a regulatory process dependent on dithiol–disulfide exchange reactions has been discovered in higher plants. A biochemical dissection of the regulatory system led to the identification of three soluble protein components required for the functioning of the signal transduction chain: an iron-sulfur protein (ferredoxin); an iron-sulfur- and disulfide-containing protein (ferredoxin-thioredoxin reductase); and a disulfide-containing protein (thioredoxin). A detailed account of how these findings occurred is given in a very recent paper.<sup>1</sup> We will present here and in a companion paper (Rouhier *et al.*,<sup>2</sup> also published in this volume) a comprehensive overview of the field of dithiol–disulfide exchange in plants, with special emphasis on the results generated in the authors' laboratories.

Address for correspondence: Jean-Pierre Jacquot, Interaction Arbres Microorganismes UMR 1136 INRA UHP, Université Henri Poincaré, BP 230, 54505 Vandoeuvre Cedex, France. Voice: ++33383684225.

j2p@scbiol.uhp-nancy.fr

<sup>a</sup>Former address: Institut de Biotechnologie des Plantes; Université de Paris-Sud, 91405 Orsay Cedex, France.

**ABBREVIATIONS:** FB Pase, fructose,1-6,bisphosphate phosphatase; Fd, ferredoxin; FTR, ferredoxin-thioredoxin reductase; NADP-MDH, NADPH-dependent malate dehydrogenase; Trx, thioredoxin.

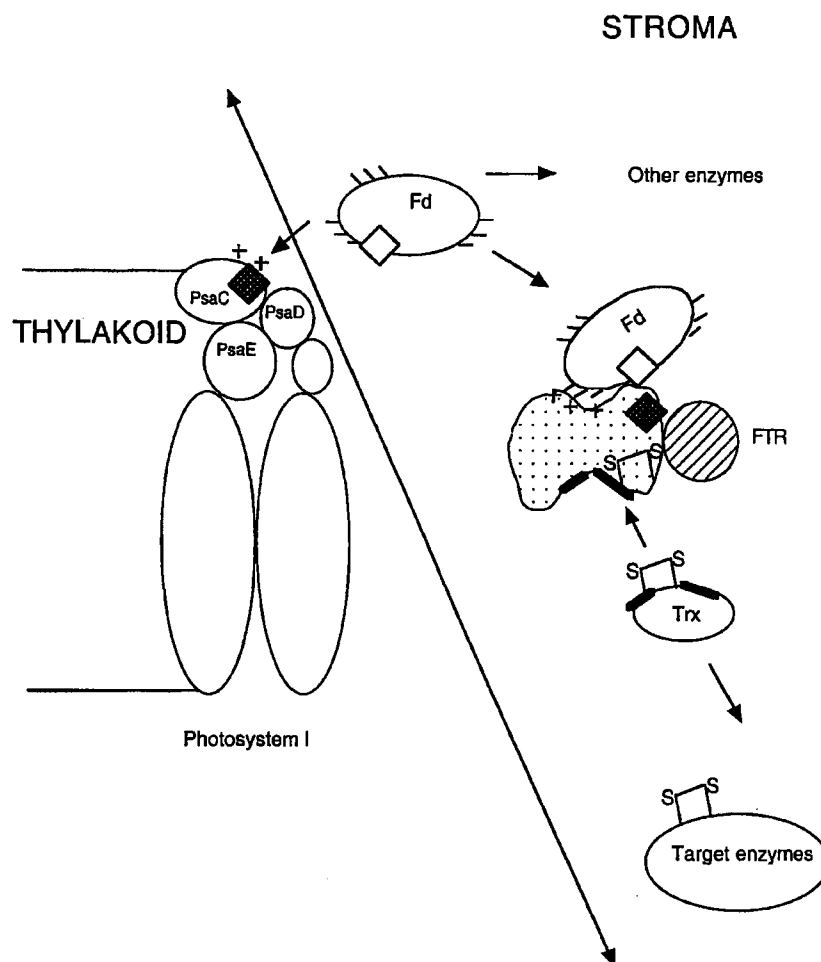

**FIGURE 1.** The chloroplast ferredoxin-thioredoxin system. The  $\text{Fe}_4\text{S}_4$  iron-sulfur centers are symbolized by *dark diamonds*; the  $\text{Fe}_2\text{S}_2$  centers, by *light diamonds*. The hydrophobic surface recognition area of FTR and thioredoxin is symbolized by a *bold line*. The + and - symbols indicate positive and negative charges.

## DESCRIPTION OF THE CHLOROPLASTIC REDUCTION SYSTEMS

FIGURE 1 summarizes the composition and functioning of the chloroplast signal transduction chain uncovered in plants. In the chloroplast system and in the light, ferredoxin (Fd) is photoreduced by photosystem I and gains one electron, going from the  $\text{Fe}^{3+}\text{Fe}^{3+}$  form to a  $\text{Fe}^{2+}\text{Fe}^{3+}$  form. The reducing power is transmitted to the disulfide bridge of ferredoxin thioredoxin reductase (FTR) in a step that requires a stabilization via the iron-sulfur center of FTR. The dithiol of FTR is then able to reduce the disulfide bond of thioredoxin (Trx) with concomitant reoxidation of FTR. The last step of the cascade is the reduction of disulfide bridges on target enzymes with reoxidation of thioredoxin. This chain is functional because light is constantly bringing photons and regenerating the oxidized species generated in the functioning of the system. The cytosolic and mitochondrial thioredoxin systems of plants will be de-

scribed in the companion paper by Rouhier *et al.*<sup>2</sup> Several reviews have been devoted to the subject of redox regulation via dithiol–disulfide exchange in plants.<sup>3,4</sup> This review will detail the molecular mechanisms involved in the transmission of the redox signal in the chloroplastic redox regulatory chain. The description of the structures, functions, and protein–protein interaction properties of each of the individual components will be especially detailed.

### FERREDOXIN: A KEY COMPONENT CONTROLLING THE DISTRIBUTION OF REDUCING POWER

Plant stromatic soluble ferredoxin belongs to a subclass of iron-sulfur proteins. The chloroplastic protein is a very small protein (*ca.* 98 amino acids) encoded by nuclear genes as a higher molecular weight precursor that is processed upon entry in the chloroplast. The sequence of Fd is extremely conserved among species from cyanobacteria to higher plants.<sup>5</sup> This protein contains a  $\text{Fe}_2\text{S}_2$  iron-sulfur center with a very low redox potential (*ca.*  $-420$  mV). In higher plants, it is able to accept one electron from photosystem I, shifting from the oxidized state ( $\text{Fe}^{3+}\text{Fe}^{3+}$ ) to a reduced state ( $\text{Fe}^{2+}\text{Fe}^{3+}$ ). Ferredoxin is composed of a central pleated  $\beta$  sheet surrounded by three  $\alpha$  helices, each of these helices being surface accessible and containing conserved negative charges. The iron-sulfur center is situated close to the C terminal helix  $\alpha 3$ . Ferredoxin is a stromatic soluble protein component that is able to dock to PSI by making molecular contacts with the subunits encoded by the *psaC*, *psaD*, and *psaE* genes.<sup>6</sup> The PsaC subunit is very important because it contains the two terminal electron acceptors of PSI, the iron-sulfur centers FA and FB. A critical Lys residue of PsaC has been shown to be responsible for an adequate binding of ferredoxin to PSI.<sup>7</sup> It is generally assumed that the interaction of ferredoxin with PSI is based on electrostatic interactions, with negative charges of ferredoxin matching positive charges of PSI. When reduced, ferredoxin is able to separate from PSI and bind to its many electron acceptors. Ferredoxin is indeed a key component for the distribution of the reducing power in the chloroplast, since it donates electrons to ferredoxin NADP reductase for NADPH production, to sulfite reductase for the incorporation of sulfur into organic compounds, to nitrite reductase and GOGAT (two enzymes involved in inorganic nitrogen assimilation), and to ferredoxin-thioredoxin reductase, to name just a few. Several of these protein–protein interactions have been described in detail through site-directed mutagenesis or via the elucidation of the three-dimensional structure of the complexes.<sup>5,8–11</sup> All results point out to the major role played by the electrostatic interactions in these contacts. It is believed that once ferredoxin has become close to its protein partners through the strong electrostatic interactions, a “fine tuning” of the fit between the two proteins can occur through additional hydrophobic interactions.<sup>12</sup>

### THE ELECTRONIC SIGNAL IS CONVERTED INTO A DISULFIDE REDUCTION AT THE LEVEL OF FTR

FTR is a heterodimeric enzyme present exclusively in photosynthetic organisms ranging from cyanobacteria to higher plants.<sup>13</sup> Both subunits are encoded by nuclear



genes. One subunit has a constant size (ca. 13 kDa) and bears the catalytic sites; the second subunit varies in size according to the species (from 7 kDa in cyanobacteria to 11 kDa in higher plants).<sup>14</sup> The three-dimensional structure of the *Synechocystis* enzyme has recently been solved.<sup>13</sup> The enzyme has the shape of a biconcave disc with binding sites to ferredoxin on one side and to thioredoxin on the other side. As for other ferredoxin-dependent enzymes, it was shown by cross-linking experiments and site-directed mutagenesis that the Fd/FTR interaction involves specific electrostatic interactions, with positive charges of FTR matching the negative charges of Fd. The presence of a crucial Glu residue necessary for an adequate binding in the C terminal  $\alpha 3$  helix of Fd has been clearly demonstrated.<sup>15</sup> The corresponding positive charges of FTR have not yet been identified. It is speculated that when Fd binds to FTR through these electrostatic interactions, this brings the iron-sulfur center of ferredoxin into close proximity with the redox-active center of FTR (see FIG. 1). This center is composed of a high redox potential (above +420 mV)  $Fe_4S_4$  iron-sulfur center and of a disulfide bridge (with a redox potential of -320 mV). Because of its electropositive value, the iron-sulfur center of FTR cannot participate directly in catalysis. Rather, it helps stabilize the semireduced form of the disulfide bridge of FTR in a redox mechanism unique to this class of enzymes. FTR is a unique enzyme because it converts a monoelectronic signal from Fd (which carries only one electron) into a dielectronic signal needed for the reduction of the disulfide bridge. It is thus postulated that the enzyme will first "stock" one electron from Fd and then use a second Fd molecule to perform the full reduction of the disulfide.<sup>16</sup> The three-dimensional crystallographic structure reveals that the  $Fe_4S_4$  center and the disulfide bridge are situated in close proximity, in agreement with the postulated mechanism. In addition, the disulfide bridge is close to the surface of the Trx interaction site. Overall, the structure of FTR seems to be extremely well adapted to the electron transfer with defined contact sites with the two interacting partner proteins and an optimization of the distances between the catalytic sites.

#### THE DITHIOL-DISULFIDE EXCHANGE REACTIONS START AT THE LEVEL OF THE FTR-THIOREDOXIN INTERACTION

Based on amino acid sequences and target specificity, there are at least two types of thioredoxins in higher plant chloroplasts. One type, called thioredoxin f, is the selective activator of the chloroplastic fructose-1,6-bisphosphatase; the other type, thioredoxin m, is a good activator of NADP-malate dehydrogenase.<sup>17</sup> In addition, new and possibly chloroplastic sequences have emerged that have been called thioredoxin x.<sup>18</sup> Like all thioredoxins, the chloroplastic thioredoxins contain about 110 amino acids and are encoded by nuclear genes in higher plants. These proteins are known to be extremely stable, presumably because of a high degree of secondary structure relative to the overall length of the protein. The chloroplastic thioredoxins have a very conserved active site (WCGPC[R/K]) that shows a very high reactivity in the reduction of disulfide bridges on other proteins.<sup>19</sup> Several crystallographic and NMR structures have been described for thioredoxins in higher plants and green algae.<sup>20,21</sup> All proteins share the same fold, with a central pleated  $\beta$  sheet containing five strands surrounded by  $\alpha$  helices. The active site is situated between the second-

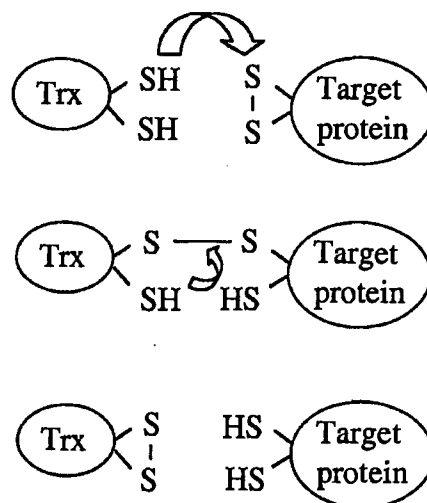
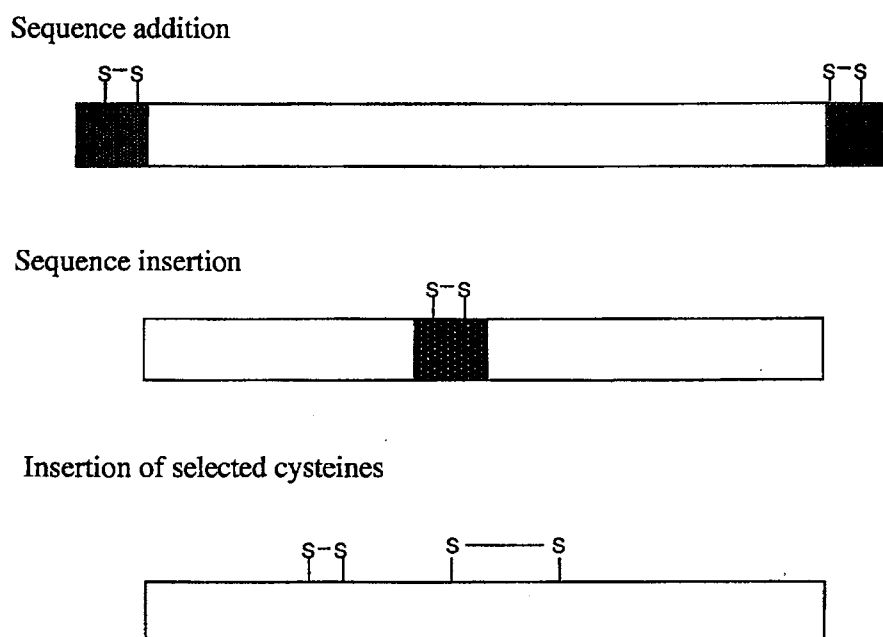

FIGURE 2. Catalytic mechanism of thioredoxin.

ary elements  $\beta 2$  and  $\alpha 3$ . The sulfur group of the catalytic cysteine is situated close to the surface of the enzyme, and the "backup" cysteine is more deeply buried. A key tryptophan residue located on the surface of the protein and an internal conserved Asp residue with an unusually high  $pK_a$  value are likely to be responsible for the very high reducing capacity of those proteins as observed in other nonphotosynthetic thioredoxins. The redox potentials of the chloroplastic thioredoxins have been titrated and found to be close to  $-300$  mV.<sup>22</sup> The sites of interaction of Trx with its partner proteins have been studied. Trx certainly comprises hydrophobic residues that surround the active site (including the conserved Trp) as well as additional positive charges in the case of the very specific thioredoxin *f*/FBPase interaction.<sup>23,24</sup>

### THIOREDOXINS REDUCE THE TARGET ENZYMES BY SIMILAR DITHIOL-DISULFIDE EXCHANGE REACTIONS

After they have been reduced in the light *via* the ferredoxin thioredoxin reductase, the active site of thioredoxin shifts into a dithiol form (see FIG. 1). As explained above, one of the thiols is the attacking cysteine, and the second one is the backup cysteine. The attacking cysteine, which presumably has a much lower  $pK_a$  and is more surface accessible, will attack the disulfide of the target enzymes, forming a transitory disulfide. This disulfide is then broken by the backup thiol of Trx with subsequent release of the reduced target enzyme and oxidation of the Trx molecule (FIG. 2). As a consequence, the preparation of monocysteinic mutants of Trx lacking the backup cysteine (integration of a Ser or Ala residue instead) results in molecular forms that will be able to bind covalently the target proteins via a mixed disulfide. This property has been used successfully to isolate several target enzymes of thioredoxins in plants.<sup>25,26</sup>



**FIGURE 3.** Models showing the alterations in primary structure of redox regulatory enzymes. Model 1 (**top**) shows additions at the N and C terminals of regulatory sequences (NADP-MDH). Model 2 (**middle**) shows insertion of a regulatory sequence (FBPase, CF1 ATPase). Model 3 (**bottom**) shows integration of selected cysteines (G6PDH, SBPase, PRK).

### REDUCTION AND ACTIVATION OF THE TARGET ENZYMES: THE NEED FOR A SLOW CONFORMATIONAL CHANGE

Nearly all of the chloroplastic enzymes that are regulated via disulfide reduction are activated, except for the chloroplastic glucose-6-phosphate dehydrogenase (G6PDH), the activity of which decreases in the light.<sup>27</sup> In higher plants, the redox regulatory enzymes are encoded by nuclear genes, and many of these enzymes have cytosolic counterparts that are constitutively active. Elucidations of the molecular mechanisms of regulation of these proteins are based in part on sequence comparisons versus the unregulated cytosolic forms. It has been observed that the sequences probably evolve from a common ancestor and that redox regulation has been gained through the addition (at the N and C terminals, NADP-malate dehydrogenase) or integration (FBPase, CF1-ATPase) of small redox regulatory modules (FIG. 3). In the above examples, these modules are short amino acid sequences (ca. 10–30 amino acids) that contain critical cysteine residues linked in a disulfide bridge.<sup>28–30</sup> In the other well-documented enzymes (sedoheptulose-1,7-bisphosphate phosphatase, G6PDH, phosphoribulokinase), there is no such addition or integration of regulatory modules; the evolution process has simply replaced selected amino acids with critical cysteine residues that form a disulfide bridge in the oxidized state.<sup>31–33</sup> (A detailed account of the primary structures of the redox-regulated enzymes was given in a previous review.<sup>4</sup>) It has been shown that the regulation of the redox-dependent enzymes is reduction dependent and that at least one disulfide bridge of the target needs to be reduced by thioredoxin. The redox potentials of several of those regula-

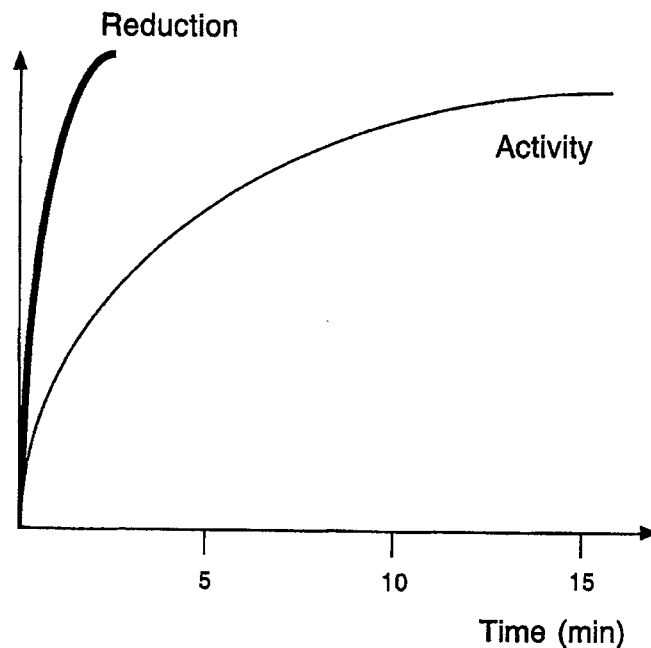
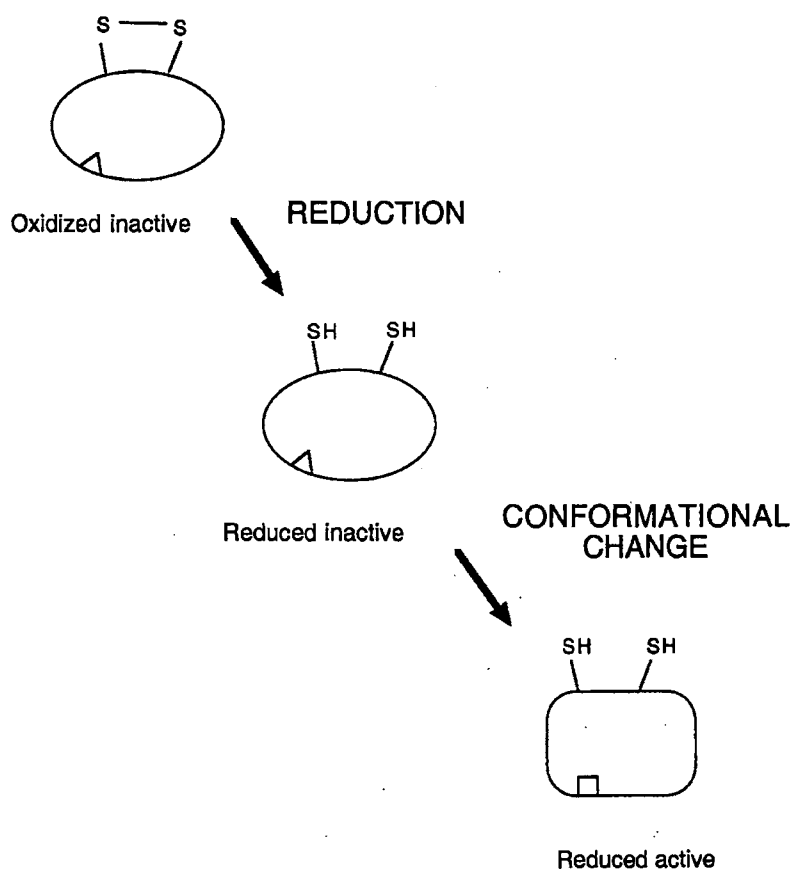

FIGURE 4. Rates of reduction and catalysis of redox regulatory enzymes.

tory disulfide bonds have been titrated especially for FBPase and NADP-malate dehydrogenase. The values range from  $-320$  to  $-280$  mV, indicating that they are nearly in redox equilibrium with thioredoxin. In the case of FBPase, the differential is even unfavorable, and it is quite clear that the reaction occurs simply because there is a constant pressure of the electron flow in the light.<sup>34,35</sup> A very peculiar property of the regulation process is that although the appearance of the catalytic activity is clearly dependent on the reduction of the disulfide bridge, it is temporally completely disconnected from the reduction (FIG. 4).<sup>36</sup> A more detailed explanation for this disconnection concerning NADP-malate dehydrogenase and FBPase is given below.

### NADP-MALATE DEHYDROGENASE

The NADP-malate dehydrogenase (NADP-MDH) is an enzyme that catalyzes the reduction of oxaloacetate into malate in the presence of NADPH. In  $C_4$  type plants, it is involved in the cycle responsible for the primary fixation of carbon; in  $C_3$  type plants, in mechanisms involved in the shuttling of reducing equivalents through the chloroplastic envelope. A fairly good understanding of the molecular mechanisms leading to the activation of NADP-MDH has been obtained through experiments based on site-directed mutagenesis and also by elucidating the three-dimensional structure of the enzyme. It has been shown that the protein contains two regulatory additions, one at the N terminus and the second one at the C terminus (see model 1 in FIG. 3). Each of these insertions contains a regulatory disulfide bridge, and since the functional enzyme is a dimer, it contains four regulatory disulfides.



**FIGURE 5.** Model for the redox regulation of chloroplastic NADP-MDH and FBPase. The active site in the closed conformation is symbolized by a *triangle*; in the open conformation, by a *rectangle*. The conformational change of the enzyme is symbolized by the alteration from the ovoid to the near-rectangular state.

The N terminus disulfide bridge controls the rate of activation of the enzyme, and it was observed that when this bridge is destroyed by replacing the cysteines with serines, the enzyme is much more quickly activated.<sup>37,38</sup> The C terminus of the enzyme also contains a disulfide. In the oxidized form it adopts a conformation similar to the one of the substrate, oxaloacetate, and it is able to occupy the pocket of the active site where the binding occurs.<sup>39,40</sup> The oxidized enzyme is thus locked in an inactive conformation because the binding of oxaloacetate is prevented by the C terminal extension of the protein. It is thus a typical example of an autoinhibiting enzyme. It is believed, but not yet proved, that once the C terminus disulfide is reduced, it displaces from the oxaloacetate binding site and opens the way to the substrate (FIG. 5). The regulatory process has been shown to be quite complex since it involves both a reduction of the N and C terminal disulfide bridges and also a subsequent transitory isomerization of the disulfide bonding involving a cysteine of the N terminus and another one present outside the two amino acid additions.<sup>40</sup> The need for these subsequent movements in the protein, following reduction, explains the phase difference observed in FIGURE 5.

### FRUCTOSE-1,6-BISPHOSPHATE PHOSPHATASE

Fructose-1,6-bisphosphate phosphatase (FBPase) is a protein that is a key regulatory component of the photosynthetic carbon reduction cycle, otherwise known as the Calvin cycle. In the presence of  $Mg^{2+}$ , this enzyme converts fructose-1,6-bisphosphate into fructose-6-phosphate with the concomitant release of inorganic phosphate. FBPase is a rather unusual regulatory enzyme because it is active either in the reduced state or in the oxidized state. When the  $Mg^{2+}$  concentration is low in the reaction medium, only the reduced form is active; but when the  $Mg^{2+}$  concentration is increased to unphysiological levels (above 10 mM), the oxidized enzyme becomes catalytically competent. The physiological activator of FBPase is thioredoxin f. (The interaction sites between the two proteins have been studied in detail.) In addition to the previously mentioned hydrophobic contacts, the selectivity of the Trx f-FBPase interaction relies also on complementary electrostatic charges, positive on thioredoxin f and negative on FBPase.<sup>24,41</sup> Analysis of the primary structure of the regulated enzyme versus the cytosolic, constitutively active form reveals an insertion of ca. 30 amino acids, an insertion that contains three conserved Cys residues. Site-directed mutagenesis combined with the elucidation of the crystallographic structure have indicated that two of these residues, separated by 20 amino acids, are indeed engaged in a disulfide bond.<sup>42,43</sup> The chloroplastic protein is a homotetramer with an overall molecular mass of 160 kDa. Each of the regulatory insertions is situated on a solvent-accessible flexible loop, distant from the active site. A comparison of the structures of the oxidized inactive and reduced active enzymes helps explain the regulation of the enzyme.<sup>43,44</sup> It is postulated that once the enzyme is reduced via thioredoxin f, the regulatory loop changes orientation, and this in turn induces a movement of two  $\beta$  strands ( $\beta 1$  and  $\beta 2$ ) that shift from a parallel to an antiparallel conformation. This is likely to cause a displacement of the side chain of a Val residue that is replaced by a glutamate. As this residue, unlike the Val, possesses a charged carboxyl group on its lateral chain, it is able to bind electrostatically the catalytic ion and bring it into close proximity to the other substrate fructose-1,6-bisphosphate. Following those movements of secondary structures and amino acid side chains, the enzyme becomes catalytically competent. This postulated mechanism of activation explains why the rates of reduction and of appearance of catalytic competence are not in phase for FBPase as well.

### CONCLUDING REMARKS

Several other chloroplastic enzymes are known to be regulated via the reduction of disulfide bridges, but the molecular nature of the modifications that occur on those enzymes is not as well documented as the above examples. A quite detailed account of these findings is reported in a paper by Meyer *et al.*<sup>3</sup> The molecular evolution of the thioredoxin systems in plants is also of great interest. It gives insights on the rationale behind these light-dependent regulation reactions that seem to be strictly linked to oxygenic photosynthesis, presumably for fighting oxidizing species. Another explanation is the need to avoid futile cycles in eukaryotic compartmented organisms. These aspects, which cannot be treated here, are developed in several review papers.<sup>3,4</sup>

## REFERENCES

1. BUCHANAN, B.B., P. SCHÜRMMANN, R.A. WOLOSUK & J.P. JACQUOT. 2002. The ferredoxin-thioredoxin system: from discovery to molecular structures and beyond. *Phot. Res.* **73**: 215–222.
2. ROUHIER, N., E. GELHAYE & J.P. JACQUOT. 2002. Redox control by dithiol–disulfide exchange in plants. II. The cytosolic and mitochondrial systems. *Ann. N.Y. Acad. Sci.* This volume.
3. MEYER, Y., L. VERDOUCQ & F. VIGNOLS. 1999. Plant thioredoxins and glutaredoxins: identity and putative roles. *Trends Plant Sci.* **4**: 387–394.
4. SCHÜRMMANN, P. & J.P. JACQUOT. 2000. Plant thioredoxin systems revisited. *Annu. Rev. Plant Physiol. Plant Mol. Biol.* **51**: 371–400.
5. TSUKIHARA, T., K. FUKUYAMA, M. MIZUSHIMA, *et al.* 1990. Structure of the [2Fe-2S]ferredoxin I from the blue-green alga *Aphanothece sacrum* at 2.2 Å resolution. *J. Mol. Biol.* **216**: 399–410.
6. VASSILIEV, I.R., Y.S. JUNG, F. YANG & J.H. GOLBECK. 1998. PsaC subunit of photosystem I is oriented with iron-sulfur cluster F(B) as the immediate electron donor to ferredoxin and flavodoxin. *Biophys. J.* **74**: 2029–2035.
7. FISCHER, N., M. HIPPLER, P. SETIF, *et al.* 1998. The PsaC subunit of photosystem I provides an essential lysine residue for fast electron transfer to ferredoxin. *EMBO J.* **17**: 849–858.
8. KNAFF, D.B. & M. HIRASAWA. 1991. Ferredoxin-dependent chloroplast enzymes. *Biochim. Biophys. Acta* **1056**: 93–125.
9. BINDA, C., A. CODA, A. ALIVERTI, *et al.* 1998. Structure of the mutant E92K of [2Fe-2S] ferredoxin I from *Spinacia oleracea* at 1.7 Å resolution. *Acta Crystallogr. D Biol. Crystallogr.* **54**: 1353–1358.
10. HURLEY J.K., J.T. HAZZARD, M. MARTINEZ-JULVEZ, *et al.* 1999. Electrostatic forces involved in orienting Anabaena ferredoxin during binding to Anabaena ferredoxin:NADP<sup>+</sup> reductase: site-specific mutagenesis, transient kinetic measurements, and electrostatic surface potentials. *Protein Sci.* **8**: 1614–1622.
11. GARCIA-SANCHEZ, M.I., A. DIAZ-QUINTANA, C. GOTOR, *et al.* 2000. Homology predicted structure and functional interaction of ferredoxin from the eukaryotic alga *Chlamydomonas reinhardtii* with nitrite reductase and glutamate synthase. *J. Biol. Inorg. Chem.* **5**: 713–719.
12. MARTINEZ-JULVEZ, M., I. NOGUES, M. FARO, *et al.* 2001. Role of a cluster of hydrophobic residues near the FAD cofactor in Anabaena PCC 7119 ferredoxin-NADP<sup>+</sup> reductase for optimal complex formation and electron transfer to ferredoxin. *J. Biol. Chem.* **276**: 27498–27510.
13. DAI, S., C. SCHWENDTMAYER, K. JOHANSSON, *et al.* 2000. How does light regulate chloroplast enzymes? Structure-function studies of the ferredoxin/thioredoxin system. *Q. Rev. Biophys.* **33**: 67–108.
14. GAYMARD, E., L. FRANCHINI, W. MANIERI, *et al.* 2000. A dicistronic construct for the expression of functional spinach chloroplast ferredoxin:thioredoxin reductase in *Escherichia coli*. *Plant Sci.* **158**: 107–113.
15. JACQUOT, J.P., M. STEIN, A. SUZUKI, *et al.* 1997. Residue Glu-91 of *Chlamydomonas reinhardtii* ferredoxin is essential for electron transfer to ferredoxin-thioredoxin reductase. *FEBS Lett.* **400**: 293–296.
16. STAPLES, C.R., E. GAYMARD, A.L. STRITT-EYER, *et al.* 1998. Role of the [Fe4S4] cluster in mediating disulfide reduction in spinach ferredoxin:thioredoxin reductase. *Biochemistry* **37**: 4612–4620.
17. STEIN, M., J.P. JACQUOT, E. JEANNETTE, *et al.* 1995. *Chlamydomonas reinhardtii* thioredoxins: structure of the genes coding for the chloroplastic m and cytosolic h isoforms; expression in *Escherichia coli* of the recombinant proteins, purification and biochemical properties. *Plant Mol. Biol.* **28**: 487–503.
18. MESTRES-ORTEGA, D. & Y. MEYER. 1999. The *Arabidopsis thaliana* genome encodes at least four thioredoxins m and a new prokaryotic-like thioredoxin. *Gene* **240**: 307–316.
19. LANCELIN, J.M., M. STEIN & J.P. JACQUOT. 1993. Secondary structure and protein folding of recombinant chloroplastic thioredoxin Ch2 from the green alga *Chlamydomonas reinhardtii* as determined by <sup>1</sup>H NMR. *J. Biochem.* **114**: 421–431.

20. CAPITANI, G., Z. MARKOVIC-HOUSLEY, G. DELVAL, *et al.* 2000. Crystal structures of two functionally different thioredoxins in spinach chloroplasts. *J. Mol. Biol.* **302**: 135–154.
21. LANCELIN, J.M., L. GUILHAUDIS, M. STEIN, *et al.* 2000. NMR structures of thioredoxin *m* from the green alga *Chlamydomonas reinhardtii*. *Prot. Struct. Funct. Genet.* **41**: 334–349.
22. HIRASAWA, M., P. SCHÜRMAN, J.P. JACQUOT, *et al.* 1999. Oxidation-reduction properties of chloroplast thioredoxins, ferredoxin-thioredoxin reductase and fructose bisphosphatase. *Biochemistry* **38**: 5200–5205.
23. KATTI, S.K., D.M. LEMASTER & H. EKLUND. 1990. Crystal structure of thioredoxin from *Escherichia coli* at 1.68 Å resolution. *J. Mol. Biol.* **212**: 167–184.
24. GECK, M.K., F.W. LARIMER & F.C. HARTMAN. 1996. Identification of residues of spinach thioredoxin *f* that influence interactions with target enzymes. *J. Biol. Chem.* **271**: 24736–24740.
25. GOYER, A., C. HALESKÖS, M. MIGINIAC-MASLOW, *et al.* 2002. Isolation and characterization of a thioredoxin-dependent peroxidase from *Chlamydomonas reinhardtii*. *Eur. J. Biochem.* **269**: 1–11.
26. MOTOHASHI, K., A. KONDOH, M.T. STUMPP & T. HISABORI. 2001. Comprehensive survey of proteins targeted by chloroplast thioredoxin. *Proc. Natl. Acad. Sci. USA* **98**: 11224–11229.
27. VON SCHAEWEN, A., G. LANGENKAMPER, K. GRAEVE, *et al.* 1995. Molecular characterization of the plastidic glucose-6-phosphate dehydrogenase from potato in comparison to its cytosolic counterpart. *Plant Physiol.* **109**: 1327–1335.
28. ISSAKIDIS, E., M. LEMAIRE, P. DECOTTIGNIES, *et al.* 1996. Direct evidence for the different roles of the N- and C-terminal regulatory disulfides of sorghum leaf NADP-malate dehydrogenase in its activation by reduced thioredoxin. *FEBS Lett.* **392**: 121–124.
29. RAINES, C.A., J.C. LLOYD, M. LONGSTAFF, *et al.* 1988. Chloroplast fructose-1,6-bisphosphatase: the product of a mosaic gene. *Nucleic Acids Res.* **16**: 7931–7942.
30. MIKI, J., M. MAEDA, Y. MUKOHATA & M. FUTAI. 1988. The gamma-subunit of ATP synthase from spinach chloroplasts. Primary structure deduced from the cloned cDNA sequence. *FEBS Lett.* **232**: 221–226.
31. DUNFORD, R.P., M.A. CATLEY, C.A. RAINES, *et al.* 1998. Purification of active chloroplast sedoheptulose-1,7-bisphosphatase expressed in *Escherichia coli*. *Protein Expr. Purif.* **14**: 139–145.
32. BRANDES, H.K., F.C. HARTMAN, T.Y. LU & F.W. LARIMER. 1996. Efficient expression of the gene for spinach phosphoribulokinase in *Pichia pastoris* and utilization of the recombinant enzyme to explore the role of regulatory cysteinyl residues by site-directed mutagenesis. *J. Biol. Chem.* **271**: 6490–6496.
33. WENDEROTH, I., R. SCHEIBE & A. VON SCHAEWEN. 1997. Identification of the cysteine residues involved in redox modification of plant plastidic glucose-6-phosphate dehydrogenase. *J. Biol. Chem.* **272**: 26985–26990.
34. HIRASAWA, M., E. RUELLAND, I. SCHEPENS, *et al.* 2000. Oxidation-reduction properties of the regulatory disulfides of sorghum chloroplast nicotinamide adenine dinucleotide phosphate-malate dehydrogenase. *Biochemistry* **39**: 3344–3350.
35. BALMER, Y., A.L. STRITT-EYER, M. HIRASAWA, *et al.* 2001. Oxidation-reduction and activation properties of chloroplast fructose 1,6-bisphosphatase with mutated regulatory site. *Biochemistry* **40**: 15444–15450.
36. MIGINIAC-MASLOW, M., P. DECOTTIGNIES, J.P. JACQUOT & P. GADAL. 1990. Regulation of corn leaf NADP-malate dehydrogenase light-activation by the photosynthetic electron flow. Effect of photoinhibition studied in a reconstituted system. *Biochim. Biophys. Acta* **1017**: 273–279.
37. MIGINIAC-MASLOW, M., K. JOHANSSON, E. RUELLAND, *et al.* 2000. Light activation of NADP-malate dehydrogenase: a highly controlled process for an optimized function. *Physiol. Plant* **110**: 322–329.
38. JOHANSSON, K., S. RAMASWAMY, M. LEMAIRE-CHAMLEY, *et al.* 1999. Structural basis for light activation of a chloroplast enzyme. The structure of sorghum NADP-malate dehydrogenase in its oxidized form. *Biochemistry* **38**: 4319–4326.



39. RUELLAND, E., K. JOHANSSON, P. DECOTTIGNIES, *et al.* 1998. The autoinhibition of sorghum NADP malate dehydrogenase is mediated by a C-terminal negative charge. *J. Biol. Chem.* **273**: 33482–33488.
40. RUELLAND, E. & M. MIGINIAC-MASLOW. 1999. Regulation of chloroplast enzyme activities by thioredoxins: activation or relief from inhibition? *Trends Plant Sci.* **4**: 136–141.
41. WANGENSTEEN, O.S., A. CHUECA, M. HIRASAWA, *et al.* 2001. Binding features of chloroplast fructose-1,6-bisphosphatase-thioredoxin interaction. *Biochim. Biophys. Acta* **1547**: 156–166.
42. JACQUOT, J.P., J. LOPEZ-JARAMILLO, M. MIGINIAC-MASLOW, *et al.* 1997. Cysteine 153 is required for redox regulation of pea chloroplast fructose-1,6-bisphosphatase. *FEBS Lett.* **401**: 143–147.
43. CHIADMI, M., A. NAVAZA, M. MIGINIAC-MASLOW, *et al.* 1999. Redox signalling in the chloroplast: structure of oxidized pea fructose-1,6-bisphosphatase. *EMBO J.* **18**: 6809–6815.
44. VILLERET, V., S. HUANG, Y. ZHANG, *et al.* 1995. Crystal structure of spinach chloroplast fructose-1,6-bisphosphatase at 2.8 Å resolution. *Biochemistry* **34**: 4299–4306.

Article numéro 2 :**Rouhier N, Gelhaye E, Jacquot JP. (2002)***Redox control by dithiol-disulfide exchange in plants: II. The cytosolic and mitochondrial systems.***Ann. N. Y. Acad. Sci. 973:520-8.**

Cet article de revue fait le point sur les systèmes de réduction cytosoliques Grx et Trx dépendant, et le système mitochondrial Trx dépendant chez les plantes. Dans le cytosol, des Trx particulières appelées h parce que présentes aussi dans les tissus hétérotrophes non photosynthétiques sont réduites en présence de NADPH et d'une flavoprotéine dimérique, la NADPH thiorédoxine réductase (NTR). Comme les autres Trx, les Trx h ont un site actif conservé du type WC[G/P]PC. Conformément à l'absence observée de sélénoenzymes chez les plantes, La NTR est du type bactérien et non animal. Il existe un système parallèle et similaire dans la mitochondrie qui utilise aussi le NADPH comme donneur et des variantes de la NTR et de la Trx h. Un système réducteur alternatif est le système composé du NADPH, de la GR et de la Grx, protéine structurellement proche des Trx mais qui possède un site actif conservé du type YCP[Y/F]C. Dans cet article, les connaissances récentes concernant les Trx h et les Grx sont rassemblées et discutées. Il est noté que peu de cibles moléculaires ont été caractérisées pour ces deux systèmes. La Prx isolée et caractérisée dans ce travail de thèse est l'une des premières cibles bien décrites.

De la même manière que pour le chloroplaste, aucune Grx n'a été localisée jusqu'à présent dans les mitochondries de plantes. Toutefois, des Grx mitochondriales ont été caractérisées chez les levures et les mammifères (Gladyshev *et al.*, 2001 ; Lundberg *et al.*, 2001 ; Rodriguez Manzaneque *et al.*, 2002) et certaines séquences d'*A. thaliana* pourraient coder des Grx mitochondriales (Tableau I). De plus, les fonctions des Grx liées à la réponse au stress oxydatif de divers organismes sont détaillées ainsi que leurs implications dans les mécanismes de glutathionylation.

# Redox Control by Dithiol–Disulfide Exchange in Plants

## II. The Cytosolic and Mitochondrial Systems

NICOLAS ROUHIER, ERIC GELHAYE, AND JEAN-PIERRE JACQUOT

*Unité Mixte de Recherches 1136 INRA UHP (Interaction Arbres Microorganismes),  
Université Henri Poincaré BP 239, 54506 Vandoeuvre Cedex, France*

**ABSTRACT:** This paper describes the existence of two pathways efficient in the reduction of disulfide bridges on selected proteins and mitochondria of photosynthetic organisms. The first is constituted by NADPH, the flavoenzyme NADPH thioredoxin reductase, and thioredoxin; and the second by NADPH, glutathione reductase, glutathione, and glutaredoxin. Molecular details concerning the proteins participating in these redox regulatory cascades are provided, and their molecular targets and functions are described.

**KEYWORDS:** disulfide; glutaredoxin; glutathione; peroxiredoxin; thioredoxin

### INTRODUCTION

Many enzymes are regulated by posttranslational modifications, and one of the most extensively described mechanisms is the phosphorylation–dephosphorylation of hydroxylated residues. Another important biochemical modification is the reversible oxidoreduction of critical cysteine residues via dithiol–disulfide exchange. In addition to the chloroplastic system described by Jacquot *et al.*,<sup>1</sup> two major systems maintain the thiol redox state in the cytosol, the thioredoxin (Trx) system, and the glutathione/glutaredoxin (GSH/Grx) systems. Both systems present many analogies with those of nonphotosynthetic bacteria and animal systems. The two systems were originally discovered in *Escherichia coli* as alternative electron donors to ribonucleotide reductase, one of the key enzymes of DNA biosynthesis.<sup>2,3</sup> In both cases, NADPH is the reductant, and the transmission of the redox signal requires a flavoprotein, either NADPH thioredoxin reductase (NTR) or glutathione reductase (GR). In the following text, we will examine in more detail the structure and function of these two systems. Some of the functions of the two reducing systems are redundant, as demonstrated notably by mutational studies.<sup>4</sup> In addition, the reaction mech-

Address for correspondence: Nicolas Rouhier, Unité Mixte de Recherches 1136 INRA UHP (Interaction Arbres Microorganismes), Université Henri Poincaré BP 239, 54506 Vandoeuvre Cedex, France. Voice: ++33383684225.

nrouhier@sbiol.uhp-nancy.fr

ABBREVIATIONS: Grx: glutaredoxin, GR: glutathione reductase, GSH: reduced glutathione, GSSG: oxidized glutathione, NTR: NADPH thioredoxin reductase, Prx: peroxiredoxins, Trx: thioredoxin.

anisms of Trx and Grx differ, essentially in one aspect. The two proteins are able to reduce disulfide bonds of target proteins with the participation of the two active site cysteines, as is the case for the reduction of the ribonucleotide reductase; but only Grx can function in an alternative pathway called the monothiol pathway. In the latter case, only the most N terminal cysteine of the active site is involved in catalyzing the reduction of GSH-containing mixed disulfides.<sup>5</sup>

## CYTOSOLIC AND MITOCHONDRIAL TRX SYSTEMS

### *The NADPH Thioredoxin Reductase of the Cytosol and Mitochondria*

The NTR is a homodimeric flavoprotein that is present both in the cytosol and the mitochondria.<sup>6,7</sup> Both proteins are encoded by nuclear genes, and the mitochondrial sequence contains a transit peptide that is subsequently cleaved. The subunits have a conserved size of 35 kDa. The crystallographic structure of the *Arabidopsis thaliana* cytosolic enzyme has been determined.<sup>8</sup> Each subunit contains two domains: one that is able to bind the NADPH; the other, the flavine adenine dinucleotide (FAD) molecule. The NADPH binding domain comprises the central part of the sequence; the FAD binding domain, the combination of the N and C termini. The protein exhibits mobility at the level of a hinge consisting of two  $\beta$  strands. Following that rotation, the NADPH binding domain is postulated to be able to get closer to the isoalloxazine ring of the FAD. Right in front of the isoalloxazine ring lies the disulfide bridge of NTR with a very conserved sequence, CAVC, which exhibits the same spacing between the two Cys residues as Trx. One of the sulfurs of the disulfide bridge is actually closer to the FAD reactive center, and this corresponds to the catalytic cysteine of NTR, the most C terminal one being the "backup" cysteine. Unlike the iron-sulfur centers, FAD is able to transfer two electrons at a time, and thus the mechanism for the reduction of the disulfide bridge of NTR is more simple than the one of the chloroplastic homologue, ferredoxin thioredoxin reductase (see Jacquot *et al.*<sup>1</sup>). The redox potential of the disulfide bridge of NTR is unknown at present.

### *The Cytosolic and Mitochondrial Thioredoxins in Plants*

It is now quite clear that multiple isoforms of thioredoxins exist in all organisms from bacteria to mammals. This property has been documented very early in plants, and it is assumed that there are nearly 35 genes coding for thioredoxin-like proteins in the very simple model *Arabidopsis thaliana*. About half of those genes encode for cytosolic Trx (also called Trx h, where h stands for heterotrophic, because cytosolic Trx is found in heterotrophic tissues as well) and two for mitochondrial Trx (they differ essentially by the presence of an N terminus transit peptide). Cytosolic thioredoxins have been described quite extensively, and their three-dimensional structure is fairly well known. The structures of the wild-type *Chlamydomonas reinhardtii* Trx h, as well as those of several mutants, have been solved both by NMR and X-ray crystallography.<sup>9,10</sup> Trx h can be identified not only by analysis of the amino acid sequences and the presence of the conserved active site WC[G/P]PC, but also by unique spectral characteristics due to a Trp residue present in the first  $\alpha$  helix of the protein (in general this residue is absent in the sequences of the other thioredoxin

types).<sup>11</sup> Thioredoxins h have a three-dimensional structure very similar to their chloroplastic counterparts, and the NMR and crystallographic structures match quite well. The  $pK_a$  values of the redox active cysteines as well as the one of a conserved Asp residue essential for catalysis have been titrated by NMR, and the values agree quite well with those published for other thioredoxins.<sup>12</sup> The redox potential of thioredoxin h has also been titrated at  $-290$  mV, and physicochemical parameters of its cold and heat denaturation properties have been measured.<sup>13</sup>

### *Molecular Targets of Cytosolic and Mitochondrial Thioredoxins*

The construction of monocysteinic mutants of Trx h has allowed the identification of one potential molecular target, a peroxiredoxin (Prx). This has been done both by *in vivo* complementation in yeast and by the successful isolation of this type of protein by using columns where a monocysteinic mutant is covalently bound.<sup>14,15</sup> These results should, however, be treated cautiously because one of the targets is a chloroplastic sequence, and the other one is a protein from yeast. Nevertheless, the existence of peroxiredoxins in plants homologous to mammalian cytosolic Prx supports the proposal that Prx could indeed be a physiological target.<sup>16</sup> Other potential targets for cytosolic Trx h could include transcription factors, as in animal and bacterial cells.<sup>17</sup> The mitochondrial Trx could play a role in the redox regulation of the alternative oxidase, an enzyme present in the plant mitochondrial inner membrane that reduces molecular oxygen with no formation of ATP.<sup>18</sup>

## **A SECOND CYTOSOLIC PATHWAY REQUIRES GLUTATHIONE REDUCTASE AND GLUTATHIONE**

In parallel to the NTR/Trx h system, the cytosol of higher plants also contains a so-called GSH/Grx system. The functioning of this system is schematized in FIGURE 1. In this alternate system, NADPH is the donor, and the electrons flow to a flavoprotein, the glutathione reductase. GR is a very well-known enzyme that shows both sequence and structural homology to NTR. As with NTR, it contains a flavin and a disulfide bridge, and the latter is reduced through the isoalloxazine ring of the flavin. When reduced, GR can in turn reduce oxidized glutathione (GSSG) into two GSH molecules by cleavage of the disulfide bridge. The reduced form of glutathione (the tripeptide  $\gamma$ Glu-Cys-Gly) then reduces a disulfide bridge on Grx, and the latter protein can in turn reduce selected target enzymes. Up to now, no plant Grx has been found in the mitochondria, unlike in mammals.<sup>19</sup> In many respects, the properties of the GSH/Grx system differ from those of the Trx system, and this results mostly from the molecular properties of the Grx that will be detailed below.

### *Molecular Properties of Plant Glutaredoxins*

Grx are proteins of low molecular weight (ca. 110 amino acids), and they contain a reactive disulfide bridge. The overwhelmingly conserved sequence of the active site is YCP[Y/F]C. In addition to this redox center, Grx possess a binding site for glutathione.<sup>20</sup> The three-dimensional structure of Grx is known only in bacteria and mammals. The protein is structurally homologous to Trx, and the active site is quite

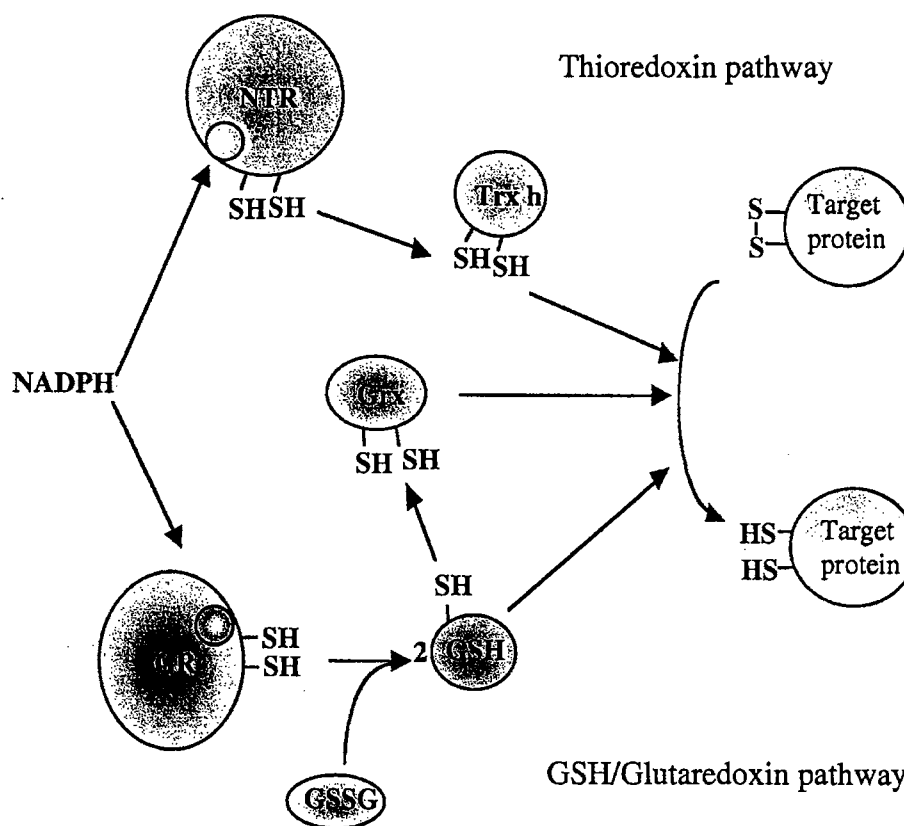

**FIGURE 1.** Two alternative cytosolic reducing pathways. The reducing power is provided by NADPH and transmitted by dithiol–disulfide exchange via the Trx and the GSH/Grx systems to reduce the target proteins.

exposed close to the surface of the protein.<sup>21</sup> One distinguishing feature of Grx is that, unlike Trx, the protein's two cysteines are not required for full activity. Also, in some reactions, monocysteinic mutants are as active as the WT protein.<sup>5</sup> The two cysteines of Grx are not equivalent in this respect, and it was found that only the one closest to the N terminus is the catalytic cysteine. The other one is dispensable. This was also shown to be true for the plant Grx, as recently demonstrated by site-directed mutagenesis with a poplar Grx.<sup>22</sup> Interestingly, plants contain many Grx genes, including several natural monocysteinic mutants that are believed to be catalytically competent. The redox potential of plant Grx is not known, but based on the rather high homology with other known Grx molecules, it can be speculated that this value should be around  $-230$  mV.<sup>23</sup> As this redox potential is not as low as the value for Trx, Grx is a weaker reductant than Trx; but it can nevertheless exhibit better reactivity with selected targets, as explained in the text that follows.

#### *Molecular Targets of Glutaredoxin in Plants*

Only few Grx were characterized in plants, in *Oryza sativa*,<sup>24</sup> *Ricinus communis*,<sup>25</sup> and *Populus trichocarpa*.<sup>26</sup> As a consequence, the identification of target proteins is less advanced. Nevertheless, the sequencing projects of many plant genomes and the development of techniques to isolate target enzymes will permit the identi-

fication of potential Grx targets. Plant glutaredoxins are capable *in vitro* of several oxidoreduction reactions, including the reduction of dehydroascorbate, which may be of significant physiological relevance.<sup>25,26</sup> Another potential target of the GSH/Grx system is a peroxiredoxin from poplar phloem, which accepts both Grx and Trx as electron donors.<sup>16</sup> As the latter protein is more active with Grx *in vitro*, it could be that Grx is the preferred donor *in vivo* as well.<sup>27</sup> Since data concerning plant Grx is scant, we will, in the following text, detail the knowledge acquired in other organisms to evaluate what the potential targets of the plant Grx could be.

### *Molecular Targets of Glutaredoxin in Other Organisms*

#### *Regulation of Protein-Glutathione Mixed Disulfide by the Grx System*

All aerobic organisms generate reactive oxygen species (such as hydrogen peroxide, superoxide ions, or hydroxyl radicals) that can damage macromolecules, especially proteins.<sup>28</sup> Indeed, the thiols of the cysteine residues are exposed to oxidation, resulting in intermolecular cross-linking and the formation of reversible sulfenic acid and/or irreversible sulfonic and sulfinic acid derivatives. One of the mechanisms to prevent an irreversible oxidation of these critical residues is the glutathiolation of the proteins at the level of these cysteines. In most cases, this leads to a reversible protein inactivation. This phenomenon represents a regulatory pathway of protein activity. Indeed, the enzymes can then be reactivated by a deglutathiolation step catalyzed mainly by Grx (FIG. 2).

For example, the catalytic activity of the HIV-1 (human immunodeficiency virus type 1) protease,<sup>29</sup> or of the human glyceraldehyde-3-phosphate dehydrogenase, was abolished after glutathiolation of conserved cysteines and probably reestablished by Grx.<sup>30</sup> In response to growth factor stimulation, mammalian cells produce reactive oxygen species leading to the formation of glutathiolated actin. Deglutathiolation of actin by Grx leads to enhancement of the rate of actin polymerization.<sup>31</sup>

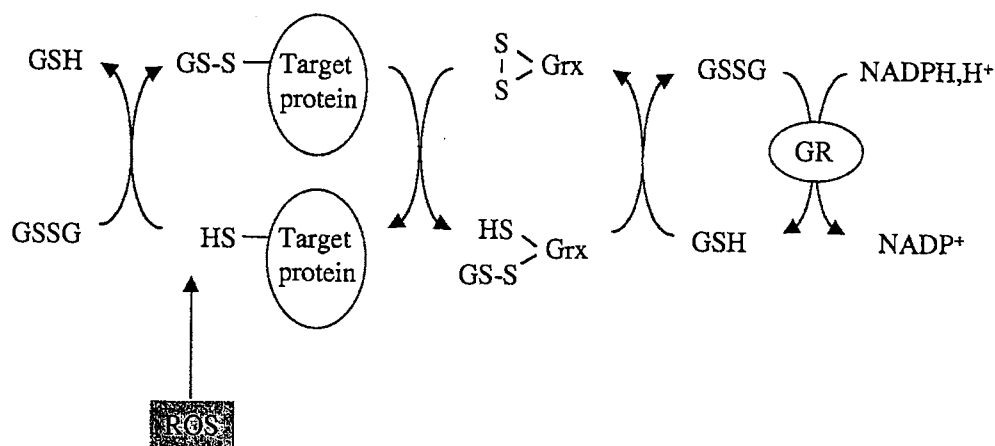

**FIGURE 2.** Glutathiolation–deglutathiolation processes. In oxidative conditions, some proteins are glutathiolated at the level of critical conserved cysteines and are then reduced by the Grx system.

*Involvement of Grx in the Transduction Signal in Response to Oxidative Stress in Other Organisms*

*Regulation of Transcription Factors.* Unlike Trx, which for some time has been well known as a regulator of transcription factors, Grx was only very recently described as contributing to these reactions. It can act as described for the NF1 (nuclear factor 1) transcription factors not only by glutathiolation/deglutathiolation processes,<sup>32</sup> but also by disulfide bond reduction of target transcription factors. The best example is the regulation in bacteria of the DNA binding activity of OxyR, which regulates the transcription of some antioxidant genes, including the Grx encoding element, which was scrutinized for its response to H<sub>2</sub>O<sub>2</sub>.<sup>33</sup> The active form of this transcription factor is a tetramer of oxidized subunits. In *Escherichia coli*, each subunit possesses six cysteines, and two are involved in the formation of an intramolecular disulfide bridge upon H<sub>2</sub>O<sub>2</sub> exposure. Once the intracellular environment is reduced, Grx deactivates OxyR by reduction of these disulfides. It appears that the OxyR response is also autoregulated by Grx through an "on-off switch."

Another example in mammals is the complex regulation of two transcription factors, the nuclear factor kappa B (NFκB) and the activating protein 1 (AP-1), which are involved in responses to stress or apoptosis. Recently, Grx was found to protect cerebellar granule neurons from dopamine-induced apoptosis by activating two different transduction pathways (the Ras/PI3K/Akt/NFκB and JNK/AP-1 cascades) leading to the activation of NFκB.<sup>34,35</sup> It seems that the signal is mediated at least in part by redox factor-1 (Ref-1), but how Grx interacts with Ref-1, Ras, and JNK has been not established. The presence of conserved cysteines in these proteins suggests the possible formation of protein-mixed glutathione disulfide.

*Regulation of the Concentration of H<sub>2</sub>O<sub>2</sub>.* At low levels, H<sub>2</sub>O<sub>2</sub> was demonstrated to serve as a messenger molecule. As a consequence, the enzymes that regulate intracellular levels of H<sub>2</sub>O<sub>2</sub> participate indirectly in the signaling processes. At least two enzymes that detoxify H<sub>2</sub>O<sub>2</sub> are able to use Grx as an electron donor. These enzymes include a human plasma glutathione peroxidase and a poplar phloem peroxidase, as mentioned earlier.<sup>26,36</sup>

*Regulation of Kinases and/or Phosphatases.* Protein kinases or phosphatases are key enzymes implicated in signal transduction. Some kinases, such as the apoptosis signal-regulating kinase 1 and protein kinase C, appear to be negatively redox regulated by Trx.<sup>37,38</sup> The action of Grx on these two types of enzymes is less well characterized. Nevertheless, at least one study, concerning a protein tyrosine phosphatase (PTP), has been published.<sup>39</sup> PTP displays one critical cysteine that is glutathiolated in oxidative conditions to avoid irreversible oxidation. PTP becomes inactive, and this glutathione-mixed disulfide can then be reduced enzymatically by Grx, leading to enzyme reactivation.

## LONG-DISTANCE TRANSMISSION OF THE REDOX SIGNAL IN PLANTS

A very interesting feature that concerns Trx, Grx, and Prx in higher plants is that all these proteins, as well as some of their RNAs, can be found at relatively high concentrations in the phloem sap.<sup>26,40,41</sup> The phloem is a tissue that carries the carbon



fixed by the photosynthetic process, essentially under the form of sucrose, from the photosynthetic parts of the plant to the nonphotosynthetic parts. This extremely specialized tissue is composed of sieve tubes connected to one another via plasmodesmata. The sieve tubes are anucleated cells that function together with a companion cell that retains the genetic information. As the phloem is highly clustered with plasmodesmata, it is also a fragile tissue. It can be attacked by viruses that spread from cell to cell and also by insects. When a plant cell is attacked by a pathogen, it will generally defend itself by generating an oxidative burst with the production of high levels of hydrogen peroxide and superoxide ions. Given the known antioxidative properties of the Trx and Grx systems, it is likely that the presence of these proteins in the phloem sap is required for correct regulation of the level of the oxidants that the plant can tolerate.

#### REFERENCES

1. JACQUOT, J.P., N. ROUHIER & E. GELHAYE. 2002. Redox control by dithiol–disulfide exchange in plants. I. The chloroplastic systems. Ann. N.Y. Acad. Sci. This volume.
2. HOLMGREN, A. 1979. Glutathione-dependent synthesis of deoxyribonucleotides. Characterization of the enzymatic mechanism of *Escherichia coli* glutaredoxin. J. Biol. Chem. **254**: 3672–3678.
3. HOLMGREN, A. 1989. Thioredoxin and glutaredoxin systems. J. Biol. Chem. **264**: 13963–13966.
4. CARMEL-HAREL, O. & G. STORZ. 2000. Roles of the glutathione- and thioredoxin-dependent reduction systems in the *Escherichia coli* and *Saccharomyces cerevisiae* responses to oxidative stress. Annu. Rev. Microbiol. **54**: 439–461.
5. QIN, J., Y. YANG, A. VELYVIS & A. GRONENBORN. 2000. Molecular views of redox regulation: three-dimensional structures of redox regulatory proteins and protein complexes. Antioxid. Redox Signal. **2**: 827–840.
6. JACQUOT, J.P., R. RIVERA-MADRID, P. MARINHO, *et al.* 1994. *Arabidopsis thaliana* NADPH thioredoxin reductase. cDNA characterization and expression of the recombinant protein in *Escherichia coli*. J. Mol. Biol. **235**: 1357–1363.
7. LALOI, C., N. RAYAPURAM, Y. CHARTIER, *et al.* 2001. Identification and characterization of a mitochondrial thioredoxin system in plants. Proc. Natl. Acad. Sci. USA **98**: 14144–14149.
8. DAI, S., M. SAARINEN, S. RAMASWAMY, *et al.* 1996. Crystal structure of *Arabidopsis thaliana* NADPH dependent thioredoxin reductase at 2.5 Å resolution. J. Mol. Biol. **264**: 1044–1057.
9. MITTARD, V., M.J. BLACKLEDGE, M. STEIN, *et al.* 1997. NMR solution structure of an oxidised thioredoxin *h* from the eukaryotic green alga *Chlamydomonas reinhardtii*. Eur. J. Biochem. **243**: 374–383.
10. MENCHISE, V., C. CORBIER, C. DIDIERJEAN, *et al.* 2001. Crystal structure of the wild-type and D30A mutant thioredoxin *h* of *Chlamydomonas reinhardtii* and implications for the catalytic mechanism. Biochem. J. **359**: 65–75.
11. LEMAIRE, S., J. RICHARDSON, A. GOYER, *et al.* 2000. pH and temperature dependent aggregation of thioredoxin. Biochim. Biophys. Acta **1476**: 311–323.
12. KRIMM, I., S. LEMAIRE, E. RUELLAND, *et al.* 1998. The single mutation W35A in the 35–40 redox site of *Chlamydomonas reinhardtii* thioredoxin *h* affects the biochemical activity and the pH dependence of C36–C39 <sup>1</sup>H-NMR but not the redox potential. Eur. J. Biochem. **255**: 185–195.
13. RICHARDSON, J.M., S. LEMAIRE, J.P. JACQUOT & G.I. MAKHATADZE. 2000. Cold and heat dependent unfolding of thioredoxin *h* from *Chlamydomonas reinhardtii* involve different mechanisms: spectroscopic and calorimetric studies. Biochemistry **39**: 11154–11162.
14. VERDOUCQ, L., J.P. JACQUOT, F. VIGNOLS, *et al.* 1999. In vivo characterization of a thioredoxin *h* target protein defines a new peroxiredoxin family. J. Biol. Chem. **274**: 19714–19722.

15. GOYER, A., C. HALESKAS, M. MIGINIAC-MASLOW, *et al.* 2002. Isolation and characterization of a thioredoxin dependent peroxidase from *Chlamydomonas reinhardtii*. *Eur. J. Biochem.* **269**: 1–11.
16. ROUHIER, N., E. GELHAYE, P.E. SAUTIERE, *et al.* 2001. Isolation and characterization of a new peroxiredoxin from poplar sieve tubes that uses either glutaredoxin or thioredoxin as a proton donor. *Plant Physiol.* **127**: 1299–1309.
17. POWIS, G., D. MUSTACICH & A. COON. 2000. The role of the redox protein thioredoxin in cell growth and cancer. *Free Radical Biol. Med.* **29**: 312–322.
18. RHOADS, D.M., A.L. UMBACH, C.R. SWEET, *et al.* 1998. Regulation of the cyanide-resistant alternative oxidase of plant mitochondria. Identification of the cysteine residue involved in alpha-keto acid stimulation and intersubunit disulfide bond formation. *J. Biol. Chem.* **273**: 30750–30756.
19. LUNDBERG, M., C. JOHANSSON, J. CHANDRA, *et al.* 2001. Cloning and expression of a novel human glutaredoxin (Grx2) with mitochondrial and nuclear isoforms. *J Biol. Chem.* **276**: 26269–26275.
20. NIKKOLA, M., F.K. GLEASON, M. SAARINEN, *et al.* 1991. A putative glutathione-binding site in T4 glutaredoxin investigated by site-directed mutagenesis. *J. Biol. Chem.* **266**: 16105–16112.
21. EKLUND, H., C. CAMBILLAU, B.M. SJOBERG, *et al.* 1984. Conformational and functional similarities between glutaredoxin and thioredoxins. *EMBO J.* **3**: 1443–1449.
22. ROUHIER, N., E. GELHAYE & J.P. JACQUOT. 2002. Exploring the active site of plant glutaredoxin by site-directed mutagenesis. *FEBS Lett.* **511**: 145–149.
23. ASLUND, F., K.D. BERNDT & A. HOLMGREN. 1997. Redox potentials of glutaredoxins and other thiol-disulfide oxidoreductases of the thioredoxin superfamily determined by direct protein-protein redox equilibria. *J. Biol. Chem.* **272**: 30780–30786.
24. MINAKUCHI, K., T. YABUSHITA, T. MASUMARA, *et al.* 1994. Cloning and sequence analysis of a cDNA encoding rice glutaredoxin. *FEBS Lett.* **337**: 157–160.
25. SZEDERKENYI, J., E. KOMOR & C. SCHOBERT. 1997. Cloning of the cDNA for glutaredoxin, an abundant sieve-tube exudate protein from *Ricinus communis* L. and characterisation of the glutathione-dependent thiol-reduction system in sieve tubes. *Planta* **202**: 349–356.
26. ROUHIER, N., E. GELHAYE, P.E. SAUTIERE & J.P. JACQUOT. 2002. Enhancement of poplar glutaredoxin expression by optimization of the cDNA sequence. *Prot. Exp. Purif.* **24**: 234–241.
27. ROUHIER, N., E. GELHAYE & J.P. JACQUOT. 2002. Glutaredoxin dependent peroxiredoxin from poplar: protein-protein interaction and catalytic mechanism. *J. Biol. Chem.* **277**: 13609–13614.
28. HALLIWELL, B. & J.M. GUTTERIDGE. 1990. Role of free radicals and catalytic metal ions in human disease: an overview. *Methods Enzymol.* **186**: 1–85.
29. DAVIS, D.A., F.M. NEWCOMB, D.W. STARKE, *et al.* 1997. Thioltransferase (glutaredoxin) is detected within HIV-1 and can regulate the activity of glutathionylated HIV-1 protease in vitro. *J. Biol. Chem.* **272**: 25935–25940.
30. LIND, C., R. GERDES, I. SCHUPPE-KOISTINEN & I.A. COTGREAVE. 1998. Studies on the mechanism of oxidative modification of human glyceraldehyde-3-phosphate dehydrogenase by glutathione: catalysis by glutaredoxin. *Biochem. Biophys. Res. Commun.* **247**: 481–486.
31. WANG, J., E.S. BOJA, W. TAN, *et al.* 2001. Reversible glutathionylation regulates actin polymerization in A431 cells. *J. Biol. Chem.* **276**: 47763–47766.
32. BANDYOPADHYAY, S., D.W. STARKE, J.J. MIEYAL & R.M. GRONOSTAJSKI. 1998. Thioltransferase (glutaredoxin) reactivates the DNA-binding activity of oxidation-inactivated nuclear factor I. *J. Biol. Chem.* **273**: 392–397.
33. ZHENG, M., F. ASLUND & G. STORZ. 1998. Activation of the OxyR transcription factor by reversible disulfide bond formation. *Science* **279**: 1718–1721.
34. DAILY, D., A. VLAMIS-GARDIKAS, D. OFFEN, *et al.* 2001. Glutaredoxin protects cerebellar granule neurons from dopamine-induced apoptosis by activating NF-kappa B via Ref-1. *J. Biol. Chem.* **276**: 1335–1344.
35. DAILY, D., A. VLAMIS-GARDIKAS, D. OFFEN, *et al.* 2001. Glutaredoxin protects cerebellar granule neurons from dopamine-induced apoptosis by dual activation of the ras-

- phosphoinositide 3-kinase and jun n-terminal kinase pathways. *J. Biol. Chem.* **276**: 21618–21626.
36. BJORNSTEDT, M., J. XUE, W. HUANG, *et al.* 1994. The thioredoxin and glutaredoxin systems are efficient electron donors to human plasma glutathione peroxidase. *J. Biol. Chem.* **269**: 29382–29384.
  37. SAITOH, M., H. NISHITOH, M. FUJII, *et al.* 1998. Mammalian thioredoxin is a direct inhibitor of apoptosis signal-regulating kinase (ASK) 1. *EMBO J.* **17**: 2596–2606.
  38. WATSON, J.A., M.G. RUMSBY & R.G. WOLOWACZ. 1999. Phage display identifies thioredoxin and superoxide dismutase as novel protein kinase C-interacting proteins: thioredoxin inhibits protein kinase C-mediated phosphorylation of histone. *Biochem. J.* **343**: 301–305.
  39. BARRETT, W.C., J.P. DEGNORE, Y.F. KENG, *et al.* 1999. Roles of superoxide radical anion in signal transduction mediated by reversible regulation of protein-tyrosine phosphatase 1B. *J. Biol. Chem.* **274**: 34543–34546.
  40. ISHIWATARI, Y., C. HONDA, I. KAWASHIMA, *et al.* 1995. Thioredoxin *h* is one of the major proteins in rice phloem sap. *Planta* **195**: 456–463.
  41. SASAKI, T., M. CHINO, H. HAYASHI & T. FUJIWARA. 1998. Detection of several mRNA species in rice phloem sap. *Plant Cell. Physiol.* **39**: 895–897.

Article numéro 3:

**Jacquot JP, Gelhaye E, Rouhier N, Corbier C, Didierjean C, Aubry A. (2002)**

*Thioredoxins and related proteins in photosynthetic organisms: molecular basis for thiol dependent regulation.*

**Biochem. Pharmacol. 64(5-6):1065-9.**

Le troisième article aborde l'étude des Trx végétales d'un point de vue plus structural et mécanistique. L'organisation du « thioredoxin fold » y est décrite et une comparaison d'une structure tridimensionnelle de Trx h de *Chlamydomonas reinhardtii* obtenue par cristallographie et par résonance magnétique nucléaire (RMN) est présentée. Il présente également un certain nombre de protéines homologues aux Trx, appelées "thioredoxin-like proteins", dont l'architecture est basée soit sur une répétition d'unités Trx soit sur la fusion entre un module Trx et un autre module d'activité différente. La géométrie du site actif, les acides aminés invariants comprenant le tryptophane du site actif et un aspartate enfoui nécessaires pour les reconnaissances protéine-protéine et la catalyse sont discutés dans cet article. Les Prx et les MsrA, deux des cibles caractérisées, sont également des enzymes qui possèdent des analogies structurales avec les Trx (Schröder & Pontig, 1998 ; Gladyshev, 2002).



## Thioredoxins and related proteins in photosynthetic organisms: molecular basis for thiol dependent regulation

Jean-Pierre Jacquot<sup>a,\*</sup>, Eric Gelhaye<sup>a</sup>, Nicolas Rouhier<sup>a</sup>, Catherine Corbier<sup>b</sup>,  
Claude Didierjean<sup>b</sup>, André Aubry<sup>b</sup>

<sup>a</sup>UMR INRA UHP Interaction Arbres Microorganismes, Université Henri Poincaré, 54506 Vandoeuvre Cedex, France

<sup>b</sup>LCM3B Groupe Biocristallographie, 54506 Vandoeuvre Cedex, France

Received 25 February 2002; accepted 22 March 2002

### Abstract

Thioredoxins are small molecular weight disulfide oxidoreductases specialized in the reduction of disulfide bonds on other proteins. Generally, the enzymes which are selectively and reversibly reduced by these proteins oscillate between an oxidized and inactive conformation and a reduced and active conformation. Thioredoxin constitutes the archetype of a family of protein disulfide oxidoreductases which comprises glutaredoxin and protein disulfide isomerase. Thioredoxin and glutaredoxin serve many roles in the cell, including the redox regulation of target enzymes and transcription factors. They can also serve as hydrogen donors to peroxiredoxins, recently discovered heme free peroxidases, the function of which is to get rid of hydroperoxides in the cell. This review describes the molecular basis for the functioning and interaction between these enzymes in photosynthetic organisms.

© 2002 Elsevier Science Inc. All rights reserved.

**Keywords:** Disulfide bridge reduction; Redox regulation; Thioredoxin

### 1. Reactions catalyzed by protein disulfide oxidoreductases

The presence of disulfide bonds is one of the major structural determinants in proteins. It is generally recognized that extracellular proteins possess disulfide bridges that help stabilize their structure, while intracellular enzymes are devoid of such features [1,2]. All polypeptides are however synthesized with free cysteine residues and in the same time that specialized proteins such as chaperones or prolyl isomerases help for the folding process, other enzymes known as protein disulfide isomerases (PDI) are needed for the creation of those disulfide bonds [3]. Conversely, some proteins which contain disulfide bridges need to be reduced to a dithiol form to gain activity and these reactions are catalyzed by thioredoxins (Trx) and other molecular variants of this protein such as glutaredoxins (Grx) [4,5]. PDI, Trx and Grx are thus members of a superfamily whose function is either to create or

reduce disulfide bonds on other proteins according to the equation:

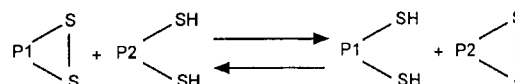

### 2. Molecular and functional characteristics of plant thioredoxins

Plant thioredoxins are small molecular weight (ca. 12 kDa) and generally extremely thermostable proteins. They contain in general around 110 amino acids in their mature form (excluding the transit peptides of the nuclear encoded chloroplastic and mitochondrial isoforms) [6,7]. All thioredoxins have a very conserved active site with the sequence WC[G/P]PC. All available structures demonstrate that the two sulfur atoms of the Cys residues of the active site are indeed linked in a disulfide bridge in the oxidized state. The 3D architecture of the protein is conserved throughout the evolution with a succession of secondary elements as follows:  $\beta$ 1,  $\alpha$ 1,  $\beta$ 2,  $\alpha$ 2,  $\beta$ 3,  $\alpha$ 3,  $\beta$ 4,  $\beta$ 5,  $\alpha$ 4. The active site is exposed and situated in the

\* Corresponding author. Tel.: +33-3-83-91-22-53.

E-mail address: j2p@scbiol.uhp-nancy.fr (J.-P. Jacquot).

Abbreviations: Grx, glutaredoxin; PDI, protein disulfide isomerase; Prx, peroxiredoxin; Trx, thioredoxin.

loop between the structural units  $\beta 2$  and  $\alpha 2$  with the second cysteine integrated in  $\alpha 2$  [8–11]. It has been demonstrated in plants as in other organisms that the active site sequence is one major determinant for the efficiency of thioredoxin as a disulfide reductase, with the conserved Trp residue next to the disulfide bridge playing an important role in the process together with a buried conserved Asp residue which exhibits an unusually high  $pK_a$  for its carboxyl side chain [12,13]. A comparison of a mean NMR structure together with the crystallographic structure obtained for a wild type *Chlamydomonas reinhardtii* cytosolic thioredoxin is shown in Fig. 1. Similar structural results are obtained using the two techniques, but the secondary elements are more defined in the crystal structure (solid

state) than in the NMR one (solution state) due to intermolecular contacts in the crystal state [9]. Interestingly, the helix  $\alpha 1$  and strands  $\beta 4$  and  $\beta 5$  are notably longer in the X-ray structure and strand  $\beta 1$  is poorly defined in the NMR structure. In addition, the disulfide bridge is completely integrated in helix  $\alpha 2$  in the crystallographic structure, but the catalytic Cys (Cys36 here) is part of the flexible loop in the NMR structure.

The redox potential of thioredoxin is also critical in governing its reactivity. Plant thioredoxins display redox potentials around  $-290$  mV, a value very similar to the one recorded for thioredoxins in other living organisms [14,15]. Likewise, the  $pK_a$  of the thiol groups of the Cys residues of the active site is also an important parameter for disulfide reductase efficiency. NMR titration has shown that the two thiol groups of *C. reinhardtii* thioredoxin h have  $pK_a$ 's of 7 and 9.5 for the catalytic and backup cysteines, respectively, values similar to those of the bacterial and mammalian enzymes [12,16–18].

A very interesting feature of thioredoxins in plants is the remarkably high number of genes that code for this protein. It has long been assumed that there was a single gene for thioredoxin in *Escherichia coli* and human cells, but recent data have shown that this was not true and that all organisms contain several thioredoxin variants [19,20]. This property has been recognized early in plants, in part because of the discovery of a specific system located in the chloroplasts. With the subsequent discovery that there are also cytosolic and mitochondrial isoforms for this protein, it is now estimated that there is a large multigenic family in plants. For example, the simple model *Arabidopsis thaliana* is estimated to contain probably more than 20 genes overall [21]. This number is likely to be even higher in species with diversified metabolism as the  $C_4$  plant maize, but no serious estimation is available yet in monocotyledonous species.

The high diversity of thioredoxins in plants is accompanied by a diversification in expression and function. It appears that some isoforms are specifically expressed in the chloroplasts, others in mitochondria and some in the cytosol of plant cells [6,7,21]. The expression of some genes seems to be tissue specific and in addition, a remarkable feature in higher plants is that thioredoxin is one major protein constituent of the phloem sap [22,23]. As this tissue permits communication throughout the plant because it is highly connected *via* specialized plasmodesmata, it is likely that thioredoxin plays a role in the long distance signaling. Other possible roles for cytosolic thioredoxins could be the detoxification of heavy metals, the dissipation of oxidative stress and the regulation of transcription factors as in mammalian or yeast cells [24–26]. The mitochondrial thioredoxin system could be involved in the regulation of 2 oxoacid dehydrogenases and alternative oxidase [27,28].

The function of chloroplastic thioredoxins is quite well documented, they serve as redox regulators of specific target enzymes which are generally inactive in the dark

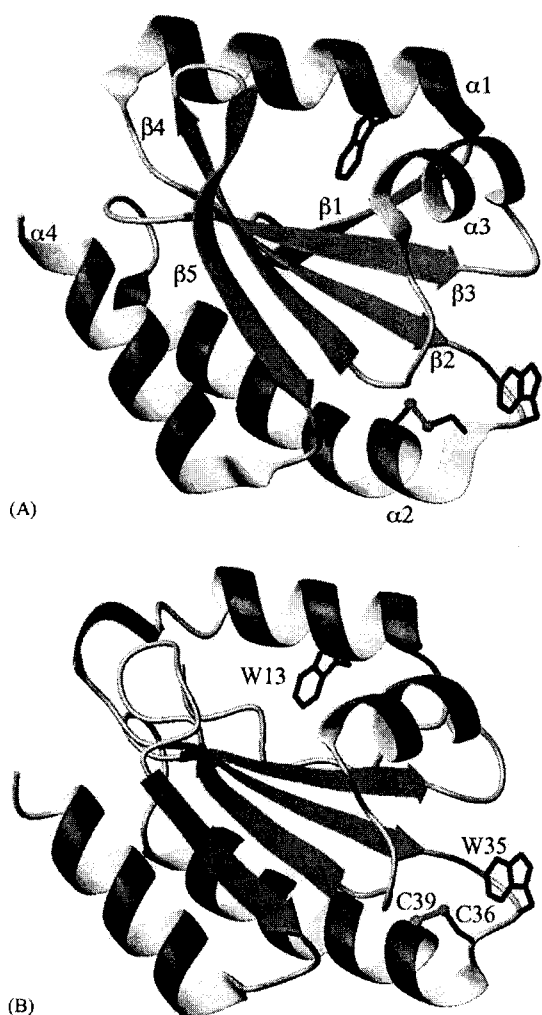

Fig. 1. Comparison of the crystallographic (A) and NMR (B) structures of *Chlamydomonas reinhardtii* thioredoxin h. The protein is shown in the strand and ribbon representation. The disulfide bridge of the active site and the sulfur atoms are in green. The two tryptophane residues (W13 which gives the protein its unique spectral characteristics and W35 adjacent to the active site) are in blue sticks. The figure has been drawn using MolMol (see [9]).

and active in the light, with the notable exception of glucose-6-phosphate dehydrogenase which is oppositely regulated. Through this redox regulation, thioredoxins help control the rate of carbon fixation through the reducing pentose phosphate pathway otherwise known as Calvin cycle [5,29]. Several of the regulatory target enzymes display additional regulatory sequences that contain critical cysteines and these cysteines can be either in a disulfide bond (oxidized form) or as dithiols (reduced state). Generally, the conversion of the oxidized inactive enzymes into reduced active catalysts occurs in two steps, first a fast reduction that produces a reduced inactive enzymes and second a slow conformational change that leads to the active catalyst [30]. The chloroplastic thioredoxin system is unique in at least two ways. First, unlike the mitochondrial and cytosolic systems where the primary reductant is NADPH relayed *via* a flavoprotein NADPH thioredoxin reductase, in chloroplasts the donor is photo-reduced ferredoxin through a specific iron–sulfur containing enzyme called ferredoxin thioredoxin reductase [31]. In addition, there are two molecular variants for thioredoxin, named thioredoxin m and thioredoxin f which display differential selectivity. More specifically, thioredoxin f is strictly required for the reductive activation of fructose-1,6-bisphosphatase and other thioredoxins cannot make the job [32]. This is in marked contrast with other systems where thioredoxins are generally considered as a promiscuous enzymes (i.e. they show no marked specificity). Details about the functioning and composition of the regulatory chloroplastic system can be found in several reviews [5,29,33,34]. In chloroplasts, thioredoxins are also involved in the removal of peroxides *via* specific chloroplastic thiol peroxidases or peroxiredoxins (Prx) [35].

### 3. Glutaredoxins, peroxiredoxins and protein disulfide isomerases share molecular determinants with thioredoxin

The 3D organization of the thioredoxin molecule is well established and referred to as the thioredoxin fold. Based on this architecture, several catalysts have evolved. By keeping basically the same secondary structural units and changing the active site to YCP[Y/F]C, one obtains a glutaredoxin molecule that is still a reductant but with a slightly higher redox potential. Glutaredoxin is reduced *via* a cascade that comprises NADPH, glutathione reductase and the tripeptide glutathione [36,37]. The combination of two thioredoxin modules together with the alteration of the active site sequence to WCGHC leads to protein disulfide isomerase, an oxidizing protein whose function is to create disulfide bonds on other proteins as discussed in the first section [38]. An even more complex version called nucleoredoxin results of the combination of three successive thioredoxin modules, the N- and C-terminus ones bearing each an active site [39]. In addition to these well

documented evolutions of thioredoxin, several sequences in the databases feature natural fusion products between a given enzyme (APS reductase or peroxiredoxin for example) together with a glutaredoxin module [40,41]. In addition, many natural monocysteine variants of thioredoxin and glutaredoxin are present in the protein data banks. These proteins are likely to be catalytically competent as it was demonstrated that engineered monocysteine glutaredoxins are also functional catalysts [42,43]. Finally, another enzyme which has a fold similar to thioredoxin is peroxiredoxin even though that protein contains a single catalytic cysteine which is transformed into a sulfenic acid upon catalysis [44]. Other examples of structurally related proteins in plants can be found in [5].

### 4. Functions of thioredoxin related catalysts in plant cells

The function of protein disulfide isomerase is linked to the folding pathway of the ER, PDI sequences containing consistently a KDEL retention sequence that targets them to this compartment [45]. It has been shown however in *C. reinhardtii* that the related protein RB60 which also contains the KDEL signal is targeted both to the ER and to the chloroplast [46]. It has been proposed to play a role as a regulator of chloroplast translational activation [47]. On the other hand, the function of nucleoredoxin is poorly documented but believed to be related to the redox regulation of transcription factors [39]. In plants, glutaredoxins seem to be restricted to the cytosol. This protein has been shown to possess the capacity to reduce dehydroascorbate which could be of physiological significance [43]. Another role proposed for glutaredoxin is to serve as an electron donor to a subclass of peroxiredoxin [48]. In this respect, both the thioredoxin and glutaredoxin pathways could be implicated in the removal of hydroperoxides and the fight against oxidative stress.

### 5. Future challenges of redox regulation in plants

The high number of genes coding for thioredoxins and related proteins poses the problem of the specificity and possible redundancy of each of these products. This question is starting to be addressed using the double hybrid technique, the yeast and *Synechocystis* complementation approach and the biochemical isolation of targets. Indeed, the use of engineered monocysteine mutants has helped isolate targets for given thioredoxin types, but the specificity of this approach needs to be assessed carefully with other parameters such as the putative subcellular localization of the partner proteins [49]. Using the yeast complementation, some specificity is observed between the various isoforms notably concerning the growth on sulfate or methionine sulfoxide and the resistance to hydrogen

peroxide but it is not clear yet that this is of physiological significance [50–53]. Recent attempts to obtain knockout mutants in *Arabidopsis thaliana* by successive PCR screening of transposon transformed pools, have been successful, but generally no clear phenotype appears under physiological conditions. Clearly, sorting out the physiological function for each of these proteins will be a challenge for the years to come.

## References

- [1] Brumlik MJ, van der Goot FG, Wong KR, Buckley JT. The disulfide bond in the *Aeromonas hydrophila* lipase/acyltransferase stabilizes the structure but is not required for secretion or activity. *J Bacteriol* 1997;179:3116–21.
- [2] Fra AM, Fagioli C, Finazzi D, Sitia R, Alberini C. Quality control of ER synthesized proteins: an exposed thiol group as a three-way switch mediating assembly, retention and degradation. *EMBO J* 1993;12:4755–61.
- [3] Winter J, Klappa P, Freedman RB, Lilie H, Rudolph R. Catalytic activity and chaperone function of human protein-disulfide isomerase are required for the efficient refolding of proinsulin. *J Biol Chem* 2002;277:310–7.
- [4] Holmgren A. Antioxidant function of thioredoxin and glutaredoxin systems. *Antioxid Redox Signal* 2000;2:811–20.
- [5] Schürmann P, Jacquot JP. Plant thioredoxin systems revisited. *Ann Rev Plant Physiol Plant Mol Biol* 2000;51:371–400.
- [6] Laloï C, Rayapuram N, Chartier Y, Grienenberger JM, Bonnard G, Meyer Y. Identification and characterization of a mitochondrial thioredoxin system in plants. *Proc Natl Acad Sci USA* 2001;98:14144–9.
- [7] Stein M, Jacquot JP, Jeannette E, Decottignies P, Hodges M, Lancelin JM, Mittard V, Schmitter JM, Miginiac-Maslow M. *Chlamydomonas reinhardtii* thioredoxins: structure of the genes coding for the chloroplastic m and cytosolic h isoforms; expression in *Escherichia coli* of the recombinant proteins, purification and biochemical properties. *Plant Mol Biol* 1995;28:487–503.
- [8] Capitani G, Markovic-Housley Z, DelVal G, Morris M, Jansonius JN, Schürmann P. Crystal structures of two functionally different thioredoxins in spinach chloroplasts. *J Mol Biol* 2000;302:135–54.
- [9] Menchise V, Corbier C, Didierjean C, Saviano M, Benedetti E, Jacquot JP, Aubry A. Crystal structure of the wild-type and D30A mutant thioredoxin h of *Chlamydomonas reinhardtii* and implications for the catalytic mechanism. *Biochem J* 2001;359:65–75.
- [10] Mittard V, Blackledge MJ, Stein M, Jacquot JP, Marion D, Lancelin JM. NMR solution structure of an oxidised thioredoxin h from the eukaryotic alga *Chlamydomonas reinhardtii*. *Eur J Biochem* 1997;243:674–8.
- [11] Lancelin JM, Guilhaudis L, Krimm I, Blackledge MJ, Marion D, Jacquot JP. NMR structures of thioredoxin m from the green alga *Chlamydomonas reinhardtii*. *Proteins* 2000;41:334–49.
- [12] Krimm I, Lemaire S, Ruelland E, Miginiac-Maslow M, Jacquot JP, Hirasawa M, Knaff DB, Lancelin JM. The single mutation W35A in the 35–40 redox site of *Chlamydomonas reinhardtii* thioredoxin h affects the biochemical activity and the pH dependence of C36–C39 1H-NMR but not the redox potential. *Eur J Biochem* 1998;255:185–95.
- [13] Menchise V, Corbier C, Didierjean C, Jacquot JP, Benedetti E, Aubry A, Saviano M. Crystal structure of the W35A mutant thioredoxin h of *Chlamydomonas reinhardtii*: the substitution of the conserved active site Trp leads to modifications in the environment of the two catalytic cysteines. *Biopolymers* 2000;56:1–7.
- [14] Hirasawa M, Schürmann P, Jacquot JP, Manieri W, Jacquot P, Keryer E, Hartman F, Knaff DB. Oxidation–reduction properties of chloroplast thioredoxins, ferredoxin–thioredoxin reductase and fructose biphosphatase. *Biochemistry* 1999;38:5200–5.
- [15] Balmer Y, Stritt-Etter AL, Hirasawa M, Jacquot JP, Keryer E, Knaff DB, Schürmann P. Oxidation–reduction and activation properties of chloroplast fructose-1,6-biphosphatase with mutated regulatory site. *Biochemistry* 2001;40:15444–50.
- [16] Dyson HJ, Jeng MF, Tennant LL, Slaby I, Lindell M, Cui DS, Kuprin S, Holmgren A. Effects of buried charged groups on cysteine thiol ionization and reactivity in *Escherichia coli* thioredoxin: structural and functional characterization of mutants of Asp 26 and Lys 57. *Biochemistry* 1997;36:2622–36.
- [17] Huber-Wunderlich M, Glockshuber R. A single dipeptide sequence modulates the redox properties of a whole enzyme family. *Fold Des* 1998;3:161–71.
- [18] Kortemme T, Creighton TE. Ionisation of cysteine residues at the termini of model alpha-helical peptides. Relevance to unusual thiol pK<sub>a</sub> values in proteins of the thioredoxin family. *J Mol Biol* 1995;253:799–812.
- [19] Lillig CH, Prior A, Schwenn JD, Aslund F, Ritz D, Vlamis-Gardikas A, Holmgren A. New thioredoxins and glutaredoxins as electron donors of 3'-phosphoadenylylsulfate reductase. *J Biol Chem* 1999;274:7695–8.
- [20] Miranda-Vizuete A, Damdimopoulos AE, Spyrou G. The mitochondrial thioredoxin system. *Antioxid Redox Signal* 2000;2:801–10.
- [21] Mestres-Ortega D, Meyer Y. The *Arabidopsis thaliana* genome encodes at least four thioredoxins m and a new prokaryotic-like thioredoxin. *Gene* 1999;240:307–16.
- [22] Brigidou C, Marty I, Chartier Y, Meyer Y. The *Nicotiana tabacum* genome encodes two cytoplasmic thioredoxin genes which are differently expressed. *Mol Gen Genet* 1993;238:285–93.
- [23] Ishiwatari Y, Honda C, Kawashima I, Nakamura S, Hirano H, Mori S, Fujiwara T, Hayashi H, Chino M. Thioredoxin h is one of the major proteins in rice phloem sap. *Planta* 1995;195:456–63.
- [24] Nishinaka Y, Masutani H, Nakamura H, Yodoi J. Regulatory roles of thioredoxin in oxidative stress-induced cellular responses. *Redox Rep* 2001;6:289–95.
- [25] Lemaire S, Keryer E, Stein M, Schepens I, Issakidis-Bourguet E, Gerard-Hirne C, Miginiac-Maslow M, Jacquot JP. Heavy-metal regulation of thioredoxin gene expression in *Chlamydomonas reinhardtii*. *Plant Physiol* 1999;120:773–8.
- [26] Kuge S, Arita M, Murayama A, Maeta K, Izawa S, Inoue Y, Nomoto A. Regulation of the yeast Yap1p nuclear export signal is mediated by redox signal-induced reversible disulfide bond formation. *Mol Cell Biol* 2001;21:6139–50.
- [27] Bunik V, Raddatz G, Lemaire S, Meyer Y, Jacquot JP, Bisswanger H. Interaction of thioredoxins with target proteins: role of particular structural elements and electrostatic properties of thioredoxins in their interplay with 2-oxoacid dehydrogenase complexes. *Protein Sci* 1999;8:65–74.
- [28] Vanlerberghe GC, McIntosh L, Yip JY. Molecular localization of a redox-modulated process regulating plant mitochondrial electron transport. *Plant Cell* 1998;10:1551–60.
- [29] Buchanan BB, Schürmann P, Jacquot JP. Thioredoxin and metabolic regulation. *Semin Cell Biol* 1994;5:285–93.
- [30] Miginiac-Maslow M, Decottignies P, Jacquot JP, Gadal P. Regulation of corn leaf NADP-Malate dehydrogenase light-activation by the photosynthetic electron flow. Effect of photoinhibition studied in a reconstituted system. *Biochim Biophys Acta* 1990;1017:273–9.
- [31] Dai S, Schwendtmayer C, Schürmann P, Ramaswamy S, Eklund H. Redox signaling in chloroplasts: cleavage of disulfides by an iron-sulfur cluster. *Science* 2000;287:655–8.
- [32] Wangensteen OS, Chueca A, Hirasawa M, Sahravy M, Knaff DB, Lopez Gorge J. Binding features of chloroplast fructose-1,6-bispho-



- sphatase-thioredoxin interaction. *Biochim Biophys Acta* 2001;154:156–66.
- [33] Dai S, Schwendtmayer C, Johansson K, Ramaswamy S, Schurmann P, Eklund H. How does light regulate chloroplast enzymes? Structure–function studies of the ferredoxin/thioredoxin system. *Q Rev Biophys* 2000;33:67–108.
- [34] Miginiac-Maslow M, Johansson K, Ruelland E, Issakidis-Bourguet E, Schepens J, Goyer A, Lemaire-Chamley M, Jacquot JP, Le Maréchal P, Decottignies P. Light activation of NADP-malate dehydrogenase: a highly controlled process for an optimized function. *Physiol Plant* 2000;110:322–9.
- [35] Baier M, Noctor G, Foyer CH, Dietz KJ. Antisense suppression of 2-cysteine peroxiredoxin in *Arabidopsis* specifically enhances the activities and expression of enzymes associated with ascorbate metabolism but not glutathione metabolism. *Plant Physiol* 2000;124:823–32.
- [36] Nordstrand K, Sandstrom A, Aslund F, Holmgren A, Otting G, Berndt KD. NMR structure of oxidized glutaredoxin 3 from *Escherichia coli*. *J Mol Biol* 2000;303:423–32.
- [37] Wells WW, Yang Y, Deits TL, Gan ZR. Thioltransferases. *Adv Enzymol Relat Areas Mol Biol* 1993;66:149–201.
- [38] Kemmink J, Darby NJ, Dijkstra K, Nilges M, Creighton TE. The folding catalyst protein disulfide isomerase is constructed of active and inactive thioredoxin modules. *Curr Biol* 1997;7:239–45.
- [39] Laughner BJ, Sehnke PC, Ferl RJ. A novel nuclear member of the thioredoxin superfamily. *Plant Physiol* 1998;118:987–96.
- [40] Bick JA, Aslund F, Chen Y, Leustek T. Glutaredoxin function for the carboxyl-terminal domain of the plant-type 5'-adenylsulfate reductase. *Proc Natl Acad Sci USA* 1998;95:8404–9.
- [41] Vergauwen B, Pauwels F, Jacquemotte F, Meyer TE, Cusanovich MA, Bartsch RG, Van Beeumen JJ. Characterization of glutathione amide reductase from *Chromatium gracile*. Identification of a novel thiol peroxidase (Prx/Grx) fueled by glutathione amide redox cycling. *J Biol Chem* 2001;276:20890–7.
- [42] Yang Y, Jao S, Nanduri S, Starke DW, Mieyal JJ, Qin J. Reactivity of the human thioltransferase (glutaredoxin) C7S, C25S, C78S, C82S mutant and NMR solution structure of its glutathionyl mixed disulfide intermediate reflect catalytic specificity. *Biochemistry* 1998;37:17145–56.
- [43] Rouhier N, Gelhaye E, Jacquot JP. Exploring the active site of plant glutaredoxin by site-directed mutagenesis. *FEBS Lett* 2002;511:145–9.
- [44] Declercq JP, Evrard C, Clippe A, Stricht DV, Bernard A, Knoops B. Crystal structure of human peroxiredoxin 5, a novel type of mammalian peroxiredoxin at 1.5 Å resolution. *J Mol Biol* 2001;311:751–9.
- [45] Ciaffi M, Paolacci AR, Dominici L, Tanzarella OA, Porceddu E. Molecular characterization of gene sequences coding for protein disulfide isomerase (PDI) in durum wheat (*Triticum turgidum* ssp. *durum*). *Gene* 2001;265:147–56.
- [46] Trebitsh T, Meiri E, Ostersetzer O, Adam Z, Danon A. The protein disulfide isomerase-like RB60 is partitioned between stroma and thylakoids in *Chlamydomonas reinhardtii* chloroplasts. *J Biol Chem* 2001;276:4564–9.
- [47] Yohn CB, Cohen A, Danon A, Mayfield SP. A poly(A) binding protein functions in the chloroplast as a message-specific translation factor. *Proc Natl Acad Sci USA* 1998;95:2238–43.
- [48] Rouhier N, Gelhaye E, Sautiere PE, Brun A, Laurent P, Tagu D, Gerard J, de Fay E, Meyer Y, Jacquot JP. Isolation and characterization of a new peroxiredoxin from poplar sieve tubes that uses either glutaredoxin or thioredoxin as a proton donor. *Plant Physiol* 2001;127:1299–309.
- [49] Goyer A, Haleskös C, Miginiac-Maslow M, Klein U, Le Maréchal P, Jacquot JP, Decottignies P. Isolation and characterization of a thioredoxin dependent peroxidase from *Chlamydomonas reinhardtii*. *Eur J Biochem* 2002;269:1–11.
- [50] Issakidis-Bourguet E, Mouaheb N, Meyer Y, Miginiac-Maslow M. Heterologous complementation of yeast reveals a new putative function for chloroplast m-type thioredoxin. *Plant J* 2001;25:127–35.
- [51] Brehelin C, Mouaheb N, Verdoucq L, Lancelin JM, Meyer Y. Characterization of determinants for the specificity of *Arabidopsis* thioredoxins h in yeast complementation. *J Biol Chem* 2000;275:31641–7.
- [52] Verdoucq L, Vignols F, Jacquot JP, Chartier Y, Meyer Y. *In vivo* characterization of a thioredoxin h target protein defines a new peroxiredoxin family. *J Biol Chem* 1999;274:19714–22.
- [53] Mouaheb N, Thomas D, Verdoucq L, Monfort P, Meyer Y. *In vivo* functional discrimination between plant thioredoxins by heterologous expression in the yeast *Saccharomyces cerevisiae*. *Proc Natl Acad Sci USA* 1998;95:3312–7.

### 3. Les protéines cibles et enzymes utilisant les glutarédoxines et thiorédoxines comme donneur de pouvoir réducteur

Les Trx et les Grx sont des protéines qui servent entre autre de donneurs d'électrons et de protons pour la réduction de ponts disulfures de protéines cibles, de manière à réguler leur activité. Le plus souvent, la forme réduite de la cible se trouve être la forme active, alors que la forme oxydée est inactive. Les protéines cibles peuvent être des facteurs de transcription, des enzymes voire des transporteurs (Tron *et al.*, 2002 ; Decottignies *et al.*, 1988 ; Gleason, 1996). Trois cas de figure sont possibles, soit les protéines cibles ne sont réduites que par les Trx, soit uniquement par les Grx, soit les deux systèmes sont capables de réduire une même protéine, éventuellement avec une efficacité différente.

De nombreuses protéines cibles des différentes isoformes de Trx ou de Grx chez les organismes végétaux sont répertoriées dans les trois articles de synthèse précédents. Ces informations sont reprises dans le Tableau II et complétées par les résultats récemment obtenus et ceux décrits dans ce manuscrit.

<b>Trx h</b>	<b><i>Lutte anti-oxydante</i></b>	
	Prx de type II	Verdoucq <i>et al.</i> , 1999
	MsrA	Ce travail
	PHGpx	Herbette <i>et al.</i> , 2002
	<b><i>Germination des graines</i></b>	
	$\alpha$ -amylase/inhibiteur de trypsine	Kobrehel <i>et al.</i> , 1991
	Albumine (gliadine, gluténine)	Kobrehel <i>et al.</i> , 1992
	Inhibiteur de la trypsine de Kunitz et Bowman	Birk
		Jiao <i>et al.</i> , 1992
	Protéine 2S	Shin <i>et al.</i> , 1993
	$\alpha$ -amylase/inhibiteur de subtilisine	Jiao <i>et al.</i> , 1993
	Inhibiteur de pullulanase	Wong <i>et al.</i> , 1995
	Thiocalsine (protéase à serine)	Besse <i>et al.</i> , 1996
	Protéines allergènes Ara h2, h3, h6*	Yano <i>et al.</i> , 2001
	Protéine de maturation des graines*	Yano <i>et al.</i> , 2001
	Protéine liée à la dessiccation*	Yano <i>et al.</i> , 2001
	Pullulanase	Wu <i>et al.</i> , 2002
	Prx à 1 cystéine*	Marx <i>et al.</i> , 2003
	Globuline 1*	Marx <i>et al.</i> , 2003
	Protéine ribosomale acide P <sup>3*</sup>	Marx <i>et al.</i> , 2003
	<b><i>Photosynthèse</i></b>	
	Phosphoenolpyruvase carboxylase protein kinase	Saze <i>et al.</i> , 2001

	<b>Reproduction</b>	
	Récepteur kinase locus S	Bower <i>et al.</i> , 1996
	<b>Transcription</b>	
	Plant homeodomain	Tron <i>et al.</i> , 2002
	Arp	Babiychuk <i>et al.</i> , 1994
	<b>Synthèse des désoxyribonucléotides</b>	
	Ribonucléotide réductase	Sauge-Merle <i>et al.</i> , 1999
Trx m, f, x	<b>Assimilation du carbone</b>	
	Fructose-1, 6 biphosphatase	Jacquot <i>et al.</i> , 1995
	Phosphoribulokinase	Milanez <i>et al.</i> , 1991
	Glycéraldéhyde-3-P déshydrogénase	Baalmann <i>et al.</i> , 1995
	Sedoheptulose-1, 7-biphosphatase	Li <i>et al.</i> , 1994
	Rubisco activase	Zhang & portis, 1999
	Transcétolase*	Balmer <i>et al.</i> , 2003
	Triose phosphate isomérase*	Balmer <i>et al.</i> , 2003
	Ribulose -phosphate 3 -épimérase*	Balmer <i>et al.</i> , 2003
	Anhydrase carbonique*	Balmer <i>et al.</i> , 2003
	<b>Métabolisme</b>	
	CF <sub>1</sub> ATPase	Schwartz <i>et al.</i> , 1997
	Glucose 6-P déshydrogénase	Gleason, 1996
	Malate déshydrogénase à NADP	Decottignies <i>et al.</i> , 1988
	ADP-glucose pyrophosphorylase	Ballicora <i>et al.</i> , 2000
	Glutamate synthase	Lichter & Häberlein, 1997
	Acétyl-CoA carboxylase	Sasaki <i>et al.</i> , 1997
	Cyclophiline	Motohashi <i>et al.</i> , 2001
	Phosphoglycérate déshydrogénase*	Balmer <i>et al.</i> , 2003
	Cystéine synthase*	Balmer <i>et al.</i> , 2003
	6-phospho-gluconate déshydrogénase*	Balmer <i>et al.</i> , 2003
	Enolase*	Balmer <i>et al.</i> , 2003
	β-amylase*	Anderson <i>et al.</i> , 1998
		Balmer <i>et al.</i> , 2003
	<b>Lutte antioxydante</b>	
	2-Cys Prx	Choi <i>et al.</i> , 1999
	Prx Q	Motohashi <i>et al.</i> , 2001
		Ce travail
	PHGpx	Jung <i>et al.</i> , 2002a
	MsrA	Ce travail
	<b>Appareil photosynthétique</b>	
	LHCII protéine kinase	Rintamäki <i>et al.</i> , 2001
	<b>Photorespiration</b>	
	Glycérate kinase*	Kleczkowski & Randall, 1985
	<b>Traduction</b>	
	RB60	Trebitch <i>et al.</i> , 2000
	Facteur d'élongation Tu*	Balmer <i>et al.</i> , 2003
	Facteur d'élongation g*	Balmer <i>et al.</i> , 2003
	Ribonucléoprotéine de 28 kDa*	Balmer <i>et al.</i> , 2003

	Sous-unité 1 de la protéine ribosomale 30S*	Balmer <i>et al.</i> , 2003
	Protéine ribosomale S6*	Balmer <i>et al.</i> , 2003
	<b>Réplication de l'ADN/ Transcription</b>	
	Hélicase à ADN ATP dépendante*	Balmer <i>et al.</i> , 2003
	<b>Dégradation des protéines</b>	
	Protéase clp ATP dépendante*	Balmer <i>et al.</i> , 2003
	<b>Assemblage des protéines</b>	
	Protéines $\alpha$ et $\beta$ de liaison à la rubisco*	Balmer <i>et al.</i> , 2003
	Protéine de choc thermique de 70 kDa	Balmer <i>et al.</i> , 2003 Vignols <i>et al.</i> , 2003
	<b>Biosynthèse des isoprénoides</b>	
	Protéine GcpE*	Balmer <i>et al.</i> , 2003
	1-déoxy-D-xylulose-5-phosphate reductoisomérase*	Balmer <i>et al.</i> , 2003
	3-deoxy-D-arabino-heptulosonate 7-phosphate synthase	Entus <i>et al.</i> , 2002
	<b>Biosynthèse des tétrapyrroles</b>	
	Glutamate-1-semialdéhyde 2, 1-aminomutase*	Balmer <i>et al.</i> , 2003
	Uroporphyrinogène decarboxylase*	Balmer <i>et al.</i> , 2003
	Magnésium chélatase*	Balmer <i>et al.</i> , 2003
	<b>Biosynthèse des vitamines</b>	
	Protéine de biosynthèse des vitamines*	Balmer <i>et al.</i> , 2003
	Enzyme thiazole biosynthétique*	Balmer <i>et al.</i> , 2003
<b>Trx o</b>	<b>Respiration</b>	
	Alternative oxydase*	Rhoads <i>et al.</i> , 1998
	2 acide oxo déshydrogénase*	Bunik <i>et al.</i> , 1999
<b>Grx</b>	<b>Lutte anti-oxydante</b>	
	Prx de type II	Rouhier <i>et al.</i> , 2001

#### Tableau II : Les différentes protéines cibles des Trx et des Grx.

La plupart des protéines cibles des Trx cytosoliques, chloroplastiques et mitochondriales et des Grx sont répertoriées dans ce tableau. L'astérisque indique que ce sont des cibles potentielles c'est-à-dire que l'interaction avec les Trx ou les Grx n'est pas clairement établie. Les interactions décrites pour les Trx chloroplastiques ne sont pas valables pour chaque isoforme. Ainsi, les Trx x ont jusqu'à présent seulement été démontrées comme étant actives dans la réduction des Prx à 2 cystéines mais pas dans la réduction de la MDH à NADP et de la FBPase. Dans le cas de la 2 acide oxo déshydrogénase, c'est une enzyme porcine qui a été utilisée avec des Trx de plantes.

## 3.1. Les peroxyrédoxines

Article numéro 4 :**Rouhier N & Jacquot JP. (2002)***Plant peroxiredoxins : alternative hydroperoxide scavenging enzymes.****Photosynthesis research* 74:259-268.**

Le quatrième article décrit les caractéristiques et les fonctions des différentes classes de Prx existant chez les végétaux, ainsi que leur mode de catalyse lorsqu'il est connu. Ainsi, une classification en quatre groupes distincts émerge selon le nombre et la position des cystéines conservées et selon l'état de dimérisation des Prx. Les Prx dites à 2 cystéines sont chloroplastiques et dimériques avec un pont disulfure intermoléculaire. Les Prx à 1 cystéine ont une localisation restreinte aux graines. Les Prx Q sont des protéines chloroplastiques et monomériques possédant un pont disulfure intramoléculaire. Les Prx de type II sont des enzymes monomériques sans pont disulfure localisées dans de nombreux compartiments cellulaires. Le Tableau III et la Figure 10 résument les informations fournies par le séquençage complet du génome d'*A. thaliana*.

	<b>Numéros d'accension</b>	<b>Longueur</b>	<b>Localisation</b>	<b>Cystéines conservées</b>
<i>Prx à 2 cys dimériques</i>				
2-Cys Prx A	At3g11630	266	chloroplastique	C <sub>119</sub> C <sub>241</sub>
2-Cys Prx B	At5g06290	273	chloroplastique	C <sub>126</sub> C <sub>248</sub>
<i>Prx à 1 cys</i>	At1g48130	216	noyau	C <sub>46</sub>
<i>Prx Q</i>	At3g26060	216	chloroplastique	C <sub>111</sub> C <sub>116</sub>
<i>Prx de type II</i>				
type IIB	At1g65980	162	cytosolique	C <sub>51</sub> C <sub>76</sub>
type IIC	At1g65970	162	cytosolique	C <sub>51</sub> C <sub>76</sub>
type IIE	At3g52960	234	chloroplastique	C <sub>121</sub> C <sub>146</sub>
type IIF	At3g06050	201	mitochondriale	C <sub>89</sub> C <sub>114</sub>

**Tableau III : Les Prx exprimées chez *A. thaliana*.**

Les 8 Prx sont réparties en 4 groupes. 2 autres séquences de type II (A et D) ont été détectées mais ne semblent pas exprimées (Dietz *et al.*, 2002 ; Horling *et al.*, 2002).

```

Prx IIB -----
Prx IIC -----
Prx IIE --MATSLS--VSRFMSS-SATVISVAKPLLSPTVSFTAPLSFTRSLAPNLSLKFRNRRTNS
Prx IIF -----MAMSILKLRNLSALRSAANSARIGVS---S--
Prx Q --MAASSS--SFTLCNHTTLRTLPLRKTTLVTKTQFSVPTKSSSESNFFGSTLTHSSYISPVS
2-Cys PrxA --MASVAS--STTLISSPSSRVFPKSSLSPPSVSFLRTLSSPSAS-ASLRSGFARRSSLS
2-Cys PrxB MSMASIASSSSTLLSS-SRVLLPSKSSLLSPTVSFPRIIPSSSASSSSSLCSGFSSLGSLT
1-Cys Prx -----

Prx IIB -----MAPIA-VGDVVPD-GTISFFDEND-QLQTASVHSLAAGKKVILFGV
Prx IIC -----MAPIT-VGDVVPD-GTISFFDEND-QLQTVSVHSLAAGKKVILFGV
Prx IIE A--SATTSRFATTPVTASIS-VGDKLPD-STLSYLDPSTGDVKTIVTVSSLTAGKKTILFAV
Prx IIF -----RGFSKLAEGTDITSAAPGVSLQKARSWDEGVSSKFSTTPLSDIFKGGKVVIFGL
Prx Q -----SSSLKGLIFAKVN-KGQAAPD---FTLKDQ---NGKPVSLKKYK-GKPVVLYFY
2-Cys PrxA ---STSRRSFAVKAQADDLPLVGNKAPDFEAEAVFDQ---EFIKVKLSDYIGKKYVILFFY
2-Cys PrxB TNRASARRNFAVKAQADDLPLVGNKAPDFEAEAVFDQ---EFIKVKLSEYIGKKYVILFFY
1-Cys Prx -----MPGIT-LGDTVPNLEVETTHDK-----FKLHDYFANSWTVLFSH

Prx IIB PGAFPTPTCSMKHVPGFIEKAEELKSKGVDEIICFSVNDPFVMKAWGKTYPE-----NKHVK
Prx IIC PGAFPTPTCSMSHVPGFIGKAEELKSKGIDEIICFSVNDPFVMKAWGKTYPE-----NKHVK
Prx IIE PGAFPTPTCSQKHVPGFVSKAGELRSKGDIVIACISVNDAFVMEAWRKDLGI-----NDEVN
Prx IIF PGAYTGVCSSQHVPSYKSHIDKFKAKGIDSVICVSVNDPFAINGWAEKLGAE-----KDAIE
Prx Q PADETPGCTK-QACAFRDSYEKFK-KAGAEVIGISGDDSASHKAFASKYKL-----PYT
2-Cys PrxA PLDFTFVCPT-EITAFSDRHSEFE-KLNTEVLGVSVDVSVFSLHAWVQTDKSGGLGDLNYP
2-Cys PrxB PLDFTFVCPT-EITAFSDRYEEFE-KLNTEVLGVSVDVSVFSLHAWVQTDKSGGLGDLNYP
1-Cys Prx PGDFTPVCTT-ELGAMAKYAHEFD-KRGVKLLGLSCDDVQSHKDWIKDIEAFNHGSKVNYN

Prx IIB FVADGSGEYTHLLGLELDLK-----DK-----GLGVRSRRFALLLD-DL
Prx IIC FVADGSGEYTHLLGLELDLK-----DK-----GLGIRSRRFALLLD-NL
Prx IIE LLSDGNGEFTGKLGVELDLR-----DKP-----VGLGVRSRRYAILAD-DG
Prx IIF FYGDFDGKFKHSLGLDKDLS-----AALLGPRSERWSAYVE-DG
Prx Q LLSDEGNKVRKDWGVPGLDF-----GALPG-RQTYVLDKNG
2-Cys PrxA LISDVTKSISKSGVLIHDQGIALRGLF IIDKEGVIQHSTINNLGIGRSVDETMRTLQ-AL
2-Cys PrxB LVSDITKSISKSGVLIIPDQGIALRGLF IIDKEGVIQHSTINNLGIGRSVDETMRTLQ-AL
1-Cys Prx I IADPNKEIIPQLNMIDPIENGPSRALHIVGPDSKIKLSFLYPSTTGRNMDEVLRALDSL

Prx IIB KVTVAN----VESG-----GEFTVSSADDILKAL-----
Prx IIC KVTVAN----VESG-----GEFTVSSAEDILKAL-----
Prx IIE VVKVLN----LEEG-----GAFTNSSAEDMLKAL-----
Prx IIF KVKAVN----VEEA--P-----SDFKVTGAEVILGQI-----
Prx Q VVQLIYN---NQFQ-----PEKHIDETLKFLLKAA-----
2-Cys PrxA QYIQENPDEVCPAGWKP-----GEKSMKPPDKLSKEYFSAI-----
2-Cys PrxB QYVQENPDEVCPAGWKP-----GEKSMKPPDKLSKEYFSAI-----
1-Cys Prx MASKHNNKIATPVNWKPDQPVVISPAVSDEEAKKMFPPQGFKTADLPSSKKGYL RHTEVS

```

Figure 10 : Comparaison de séquences des Prx d'*A. thaliana*.

Sont représentés en gris clair les acides aminés strictement conservés, en gris intermédiaire les cystéines conservées et éventuellement catalytiques dans chacun des sous-groupes et en gris foncé l'arginine du site actif.



Regular paper

## Plant peroxiredoxins: alternative hydroperoxide scavenging enzymes

Nicolas Rouhier & Jean-Pierre Jacquot\*

Unité Mixte de Recherches 1136 INRA UHP (Interaction Arbres Microorganismes), Université Henri Poincaré BP 239, 54506 Vandoeuvre Cedex, France; \*Author for correspondence (e-mail: j2p@scbiol.uhp-nancy.fr)

Received 15 February 2002; accepted in revised form 17 June 2002

**Key words:** chloroplast, detoxification, oxidative stress, peroxiredoxin, seed

### Abstract

The role of plant peroxiredoxins in the detoxification systems is discussed in relation with the existence of many isoforms of this protein in distinct plant compartments. Phylogenetic analyses indicate that plant peroxiredoxins can be divided into four classes. Two of these classes correspond to chloroplastic enzymes. All isoforms contain at least one conserved catalytic cysteine. The enzymes belonging to the 1-Cys Prx class seem to be seed restricted and to play a role of detoxification during the germination process. At least one putative cytosolic isoform can use both thioredoxin and glutaredoxin as an electron donor, but the chloroplastic isoforms characterized depend on reduced thioredoxin. Mutagenesis and plant transformation studies support the proposal that the chloroplastic peroxiredoxins play an important role in combating the ROS species generated at the level of the chloroplastic electron transfer chain.

**Abbreviations:** GSH – reduced glutathione; Grx – glutaredoxin; Prx – peroxiredoxin; ROS – reactive oxygen species; Trx – thioredoxin; TR – thioredoxin reductase

### Introduction: a new family of non heme peroxidases – the peroxiredoxins

In steady-state functioning, aerobic photosynthetic organisms generate reactive oxygen species (ROS), especially at the level of the mitochondrial and chloroplastic electron transfer chains. The concentration of these oxidizing species is very much increased when these organisms are submitted to unfavorable environmental conditions, resulting in oxidative stress (Noctor and Foyer 1998; Foyer and Noctor 2000). The evolution has created an array of antioxidant systems, composed of enzymes and low molecular weight non-enzymatic compounds, in order to fight the damages created by these ROS to macromolecules such as nucleic acids, lipids and proteins (Halliwell and Gutteridge 1990). Recently, in all kingdoms, new enzymes called peroxiredoxins (Prx) were demonstrated to be capable of participating in the detoxification systems, by reducing various alkyl hydroperoxides into water

and the corresponding alcohol. The increasing number of Prx-related sequences in the databases makes the classification of these enzymes ever more complex.

One of the remarkable features of peroxiredoxins is that they are nonheme-containing peroxidases, which have to rely on an external electron donor to compensate for the lack of prosthetic group. As this electron donor is often reduced thioredoxin, the peroxiredoxins have frequently also been called thioredoxin peroxidases. The reaction that they catalyze conforms to the following equation:

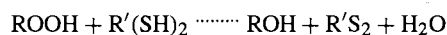

These proteins seem to be ubiquitous from archaeobacteria to mammals and they range in size from 150 to 220 amino acids in their mature form. Depending on their subunit organization and the position of the cysteines in the sequence, two classes have been differentiated, the 1-Cys Prx and 2-Cys Prx (these

sequences containing, respectively, one or two conserved cysteines). All the Prx isoforms contain a conserved cysteine in the N-terminus part which has been demonstrated to be the catalytic one by site-directed mutagenesis (Chae et al. 1994a). In all cases, the catalytic cysteine is transformed into a sulfenic acid after the reduction of the hydroperoxides. The regeneration of a reduced Prx is then quite different between the different classes.

In the 1-Cys Prx, catalysis proceeds only through the catalytic cysteine even though they sometimes display additional cysteines, which are not involved in the catalytic mechanism. The reductant of these enzymes is not clearly identified and could be either reduced glutathione (Kang et al. 1998), the thioredoxin system (Trx/TR) as described in the case of a mitochondrial Prx from *Saccharomyces cerevisiae* (Pedrajas et al. 1999), or cyclophilin as reported for the human isoform Prx VI (Lee et al. 2001) (Figure 1A).

The situation is a bit more complex among the 2-Cys Prx. Three subclasses, widely distributed among the kingdoms, can be differentiated based on the amino acid sequences and the catalytic mechanism. All the 2-Cys Prx can use thioredoxin or equivalent proteins as an electron donor.

The first, that will be called here dimeric 2-Cys Prx, which includes chloroplastic 2-Cys Prx, mammalian Prx I to IV or yeast TSA, consists of dimeric enzymes which form an intermolecular disulfide bridge between two head-to-tail identical subunits (Chae et al. 1994a; Chae et al. 1999; Goyer et al. 2002) (Figure 1, B1). In this class, we can also include the rare enzymes trypanothione peroxidase and AhpC found respectively in trypanosomatids and bacteria, because of the conserved position of the cysteines and the catalytic mechanism. For these enzymes, the reducing power comes from reduced adenine nucleotides such as NADH or NADPH, linked by homologues of thioredoxin reductase and thioredoxin or glutaredoxin (Poole 1996; Montemartini et al. 1998; Reynolds et al. 2002).

The second class, typified by mammalian Prx V, includes monomeric enzymes which form an intramolecular disulfide bridge as a reaction intermediate (Knoops et al. 1999; Seo et al. 2000). Other members of this class are the bacterioferritin co-migratory proteins (BCP) and their plant homologues called Prx Q (Kong et al. 2000; Jeong et al. 2000). In this class, the two cysteines, which are part of the disulfide bridge, are generally only separated by four amino acids, except for mammalian Prx V, where the spacing

spans over 100 amino acids. Nevertheless, the catalytic mechanism of these Prx is similar and shown in Figure 1, B2. This class is named here monomeric type I Prx.

The third class, called monomeric type II Prx, according to Dietz et al (2002), comprises enzymes described in chinese cabbage and poplar (Choi et al. 1999; Rouhier et al. 2001). These enzymes possess two conserved cysteines, only one being required for activity as described in Figure 1, B3. A unique feature of at least one of these enzymes is the possibility to use the GSH/glutaredoxin system as an electron donor (Rouhier et al. 2002).

## Peroxiredoxins in plants

### *Phylogenetic and amino acid sequences analysis*

A complete set of the above characterized isoforms is present in plants and the Figures 2 and 3 summarize the different known types of plant Prx. The construction of an unrooted phylogenetic tree with most of the available sequences of plant Prx clearly separates these sequences into four distinct groups (Figure 2). The alignment of two of these amino acid sequences, chosen randomly in each class, provides more informations and allows to define some characteristics for each group (Figure 3). Within each set, the sequences display between 75 and 90% identity, whereas across the different classes, the identities fall in the range 10–30%. Thus, each class is very well defined by its amino acid sequence.

The main class (set B1 in Figure 2) contains chloroplastic enzymes, which present a N-terminal extension that was experimentally shown as necessary for exporting the mature protein in the chloroplasts (Baier and Dietz 1997). These sequences, listed as B1 in Figure 3, contain between 260 and 275 AA including the transit peptides. The distance separating the two conserved cysteines is approximately 120 AA. The same branch of the phylogenetic tree also contains a sequence from *Chlamydomonas reinhardtii* with a shortened transit peptide and from red algae and cyanobacteria, which do not possess the N-terminal extension because the proteins are plastome encoded, whereas the others are nuclear encoded (Klughammer et al. 1998). As a consequence, these sequences are shorter by 60 to 75 AA, corresponding to the size of the transit peptide. The proteins biochemically characterized are Trx dependent (Cheong et al. 1999; Goyer



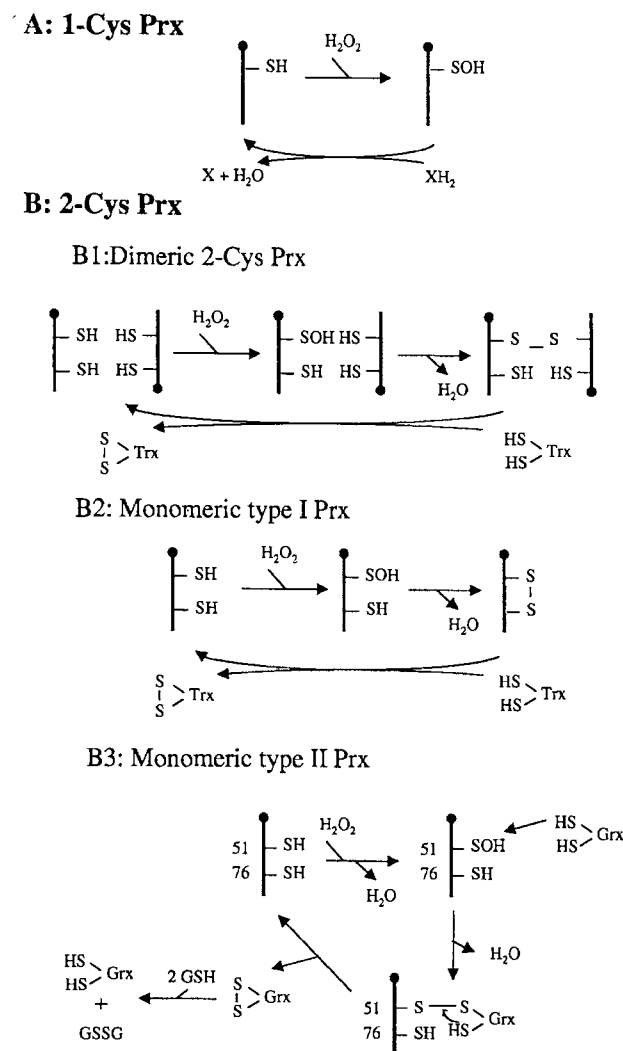

Figure 1. Catalytic mechanisms of the four distinct subclasses of peroxidoredoxins. The schemes are drawn according to Kang et al., Kong et al. and Rouhier et al. (A) 1-Cys Prx; (B) 2-Cys Prx, B1: dimeric 2-Cys Prx, B2: monomeric type I Prx, B3: monomeric type II Prx.

et al. 2002; König et al. 2002). The biochemical function of this class of chloroplastic Prx will be detailed later in this study.

Recently, another class of putative chloroplastic 2-Cys Prx was discovered and called Prx Q (set B2 in Figure 2 and sequences B2 in Figure 3). This class includes proteins of ca. 215 AA including a putative transit peptide and ca. 150 AA in the mature processed form which makes them the shortest mature proteins. These proteins accept *Escherichia coli* Trx or *Ara-bidopsis thaliana* Trx m as an electron donor (Kong

et al. 2000; Motohashi et al. 2001). The two catalytic cysteines are only separated by 4 AA.

The third class of Prx consists of proteins of 162 AA devoid of any extension, a feature which makes them the shortest encoded proteins but not the shortest mature proteins (set B3 in Figure 2 and sequences B3 in Figure 3). Because of the general absence of a transit sequence for the proteins characterized so far, these Prx are assumed to be cytosolic, but this assumption is not always perfectly safe since an immunolocalization study indicates that the Prx from poplar

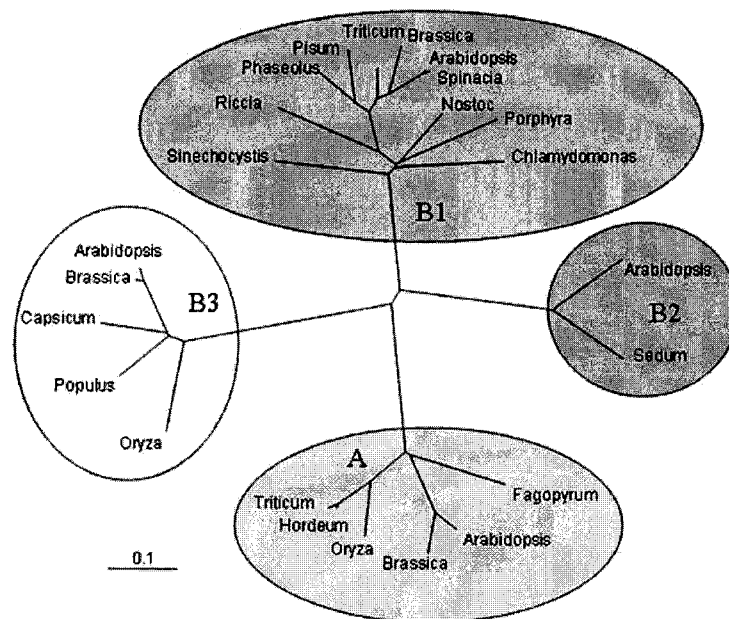

Figure 2. Unrooted phylogenetic tree of the different plant peroxiredoxins constructed using the Clustalw and Treeview softwares. A: 1-Cys Prx; B1: dimeric 2-Cys Prx; B2: monomeric type I Prx; Set B3: monomeric type II Prx.

is located in plastid-like structures contained in the phloem sieve tubes (Rouhier et al. 2001). Moreover, at least two strongly homologous sequences found in the protein databank, from *Arabidopsis thaliana* and *Oryza sativa*, present an N-terminal extension, which is predicted to export the proteins either in chloroplast or in mitochondria (accession numbers NP\_190864 and BAA82377). Although these proteins possess two conserved cysteines distant of 25 AA, they function catalytically as 1-Cys Prx (see below).

Finally, the last class of plant Prx comprises proteins of 216 to 220 AA and are referred to as 1-Cys Prx (set A in Figure 2 and sequences A in Figure 3). These proteins do not display a N-terminal extension but rather a C-terminal one, which is predicted to contain an NLS signal exporting the protein to the nucleus (Stacy et al. 1999).

#### Function of peroxiredoxins in plants

Up to now, the functions of the different plant Prx have not been evenly characterized in all subclasses, but all enzymes appear to have a common function of alkyl hydroperoxide detoxification in the different plant compartments. The putative *in vivo* functions of

the various plant types are detailed below, except for those of set B2, for which no additional information is yet available.

#### The chloroplastic detoxification systems: is there a role for the dimeric 2-Cys peroxiredoxins?

The major source of production of the ROS in the chloroplast is located at the level of PS I where  $O_2$  combines with the reduced species generated by the functioning of this photosystem, producing superoxide ions and then hydrogen peroxide (Figure 4). A complex chloroplastic detoxification system, called the Halliwell and Asada cycle fights against these ROS and is composed of glutathione and ascorbate and of known enzymes such as superoxide dismutases, monodehydroascorbate reductases and dehydroascorbate reductases (Asada 1999).

A high number of hydroperoxide scavenging enzymes also exists in the chloroplast. First, there are two different ascorbate peroxidases (APx), one stromal and another one thylakoid-bound, which play a crucial role in the reduction of hydrogen peroxide but not of alkyl hydroperoxides (Asada 1999). Addi-



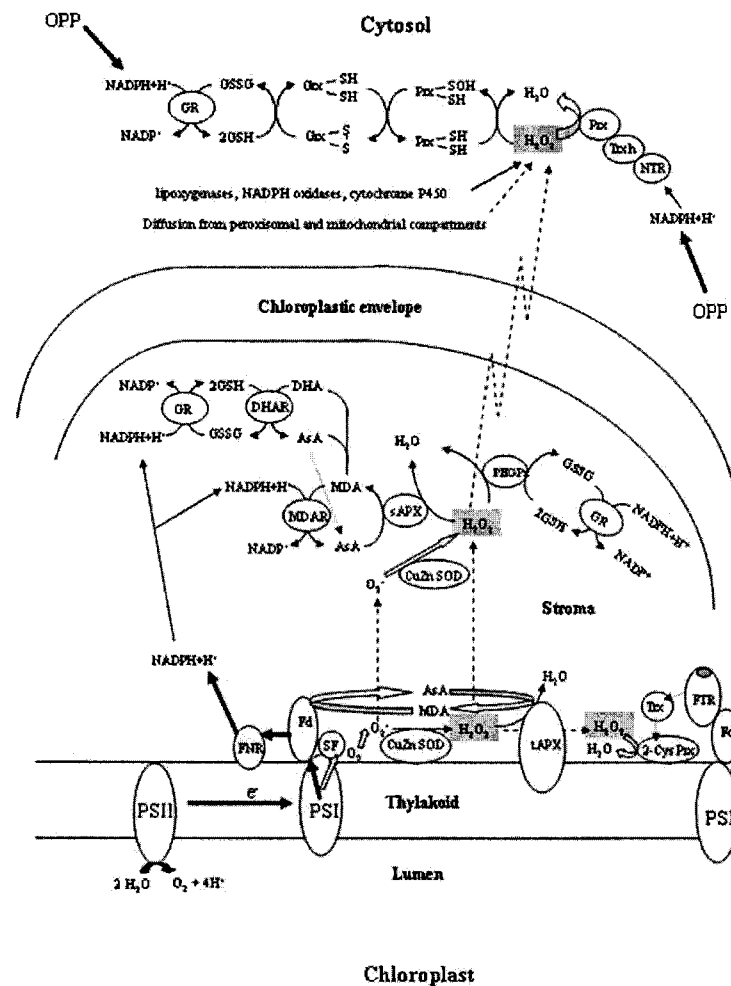

**Figure 4.** Pathways for  $\text{H}_2\text{O}_2$  reduction in the chloroplast and in the cytosol of higher plants. The scheme depicts in part the water–water cycle described in Asada (1999).  $\text{O}_2^-$  is produced directly at the level of the Photosystem I (PS I) or indirectly by a stromal factor (SF), maybe the monodehydroascorbate reductase (MDAR). This radical is then transformed into  $\text{H}_2\text{O}_2$  by a thylakoid-bound superoxide dismutase (SOD), either MnSOD or FeSOD. In the chloroplast, at least four  $\text{H}_2\text{O}_2$  reducing systems exist, two involve the stromal and thylakoid-bound ascorbate peroxidases (sAPx and tAPx), one a phospholipid hydroperoxide glutathione peroxidase (PHGPx) reduced by glutathione (GSH) and one a thylakoid-bound dimeric 2-Cys Prx, presumably reduced by the chloroplastic thioredoxin system composed of ferredoxin (Fd), ferredoxin thioredoxin reductase (FTR) and thioredoxin (Trx). An additional putative  $\text{H}_2\text{O}_2$  reducing system could be the monomeric type I Prx. In the cytosol, a monomeric type II Prx was found to accept both thioredoxin h (Trx h) and glutaredoxin (Grx) as electron donors to reduce  $\text{H}_2\text{O}_2$  with reducing power provided by  $\text{NADPH}+\text{H}^+$  and a NADPH thioredoxin reductase (NTR) or a glutathione reductase (GR) and GSH, respectively.  $\text{H}_2\text{O}_2$  could diffuse from other subcellular compartments (chloroplasts, peroxisomes or mitochondria) or arise from the functioning of cytosolic enzymes. Other abbreviations: AsA – ascorbic acid; GSSG – oxidized glutathione; DHA – dehydroascorbate; MDA – monodehydroascorbate; DHAR – dehydroascorbate reductase; FNR – ferredoxin NADPH reductase; OPP – oxidative pentose phosphate pathway.

ertheless, PHGPx could contribute to the reduction of other alkyl hydroperoxides. Moreover, enzymes homologous to PHGPx were recently characterized and found to reduce hydroperoxides more efficiently in the presence of Trx as an alternate donor to glutathione

(Herbette et al. 2002; Jung et al. 2002). Concerning the thylakoid-bound enzymes, APx is also more efficient for the reduction of  $\text{H}_2\text{O}_2$  than the dimeric 2-Cys Prx when comparing the specific activities, but contrary to APx, the dimeric 2-Cys Prx, is able to detoxify other

hydroperoxides *in vitro* such as cumene hydroperoxide or tert-butyl hydroperoxide (König et al. 2002). The thylakoid-bound localization of the Prx suggests also that these proteins could combat lipid peroxidation, which causes damage to the membranes of the thylakoids. König et al (2002) propose that the 2-Cys Prx could act not only in the water-water cycle pathway for energy dissipation in photosynthesis, but also in the peroxide detoxification in the plastids during the dark phase.

The function of the 2-Cys Prx was verified *in vivo* by complementing an *Escherichia coli* deficient strain for the AhpC gene, the bacterial equivalent of 2-Cys Prx (Baier et al. 1997). In addition, the Prx Q (set B2 in Figure 2) are also assumed to be chloroplastic and to detoxify the alkyl hydroperoxides *in vitro* but the localization of these proteins has not yet been described. The reduction of hydroperoxides by these two types of chloroplastic Prx is presumed to be directly associated with the photosynthetic electron transfer chain because of the thioredoxin dependence of the Prx (König et al. 2002).

In order to investigate the importance of the 2-Cys Prx in the detoxification process, the effect of a suppression in *Arabidopsis thaliana* was studied by engineering antisense plants (Baier and Dietz 1999a). The results suggest an essential role of the 2-Cys Prx in the protection of the chloroplastic structure against oxidative damage because the levels of D1 protein, ribulose-1,5-bisphosphate carboxylase/oxygenase, the light-harvesting protein complex associated with Photosystem II and the subunit CFI of the chloroplast ATP synthase decrease. It was also concluded that neither the lipid hydroperoxide reductase, nor the glutathione peroxidase can substitute for dimeric 2-Cys Prx probably because of different suborganellar localization of these proteins, which leads to specific physiological functions. The antisense suppression of the 2-Cys Prx does not induce a change in the transcriptional expression of the enzymes involved in glutathione metabolism, or of the chloroplastic glutathione peroxidase, and it has a weak effect on the abundance of transcripts for glutathione reductase, superoxide dismutase and catalase (Baier et al. 2000). On the contrary, the level of transcripts and the enzymatic activities of the stromal and thylakoidal ascorbate peroxidases and of monodehydroascorbate reductase increase. In this mutant, the pool of ascorbate is highly oxidized. The importance of reduced ascorbate in the redox regulation of the 2-Cys Prx was recently studied in *Riccia fluitans* (Horling et al. 2001). When the level of ROS

decreases, the pool of reduced ascorbate increases and induces a decrease of the 2-Cys Prx transcript level and the redox signaling cascade from the chloroplast to the nucleus could be linked in part to a protein kinase.

The 2-Cys Prx belongs to a multigenic family and is expressed in all organs of the mature plant, except in the roots (Cheong et al. 1999; Genot et al. 2001). There is a gradient of expression of the 2-Cys Prx gene from the young leaves to the mature leaves, whereas the expression decreases in aged tissues and, as a consequence, this protein could play an important role in the early stages of plant development when the cells are dividing or elongating (Baier and Dietz 1996; Cheong et al. 1999). An additional proof of the importance of the 2-Cys Prx is the severe effect on the growth of a strain of *Synechocystis sp* deleted for this gene (Klughhammer et al. 1998). The expression of the 2-Cys Prx is induced in response to H<sub>2</sub>O<sub>2</sub> and to illumination but quite weakly by methyl viologen or metals, and it is not induced in response to ozone, or abscisic acid and gibberellic acid treatments (Baier and Dietz 1997; Cheong et al. 1999; Genot et al. 2001; Goyer et al. 2002).

A last piece of information about this type of enzymes is its possible endosymbiotic origin. Indeed, in the red algae *Porphyra purpurea*, the 2-Cys Prx is plastome-encoded whereas in *Arabidopsis thaliana*, the 2-Cys Prx is nuclear encoded and the transit peptide is encoded by a separate exon supporting the hypothesis that this extension has been added during evolution (Klughhammer et al. 1998).

### 1-Cys Prx: a function restricted to seeds?

The 1-Cys Prx are 216 to 220 AA long and compared to the other classes of Prx, these proteins possess a C-terminal extension, which contains a putative nuclear signal. An immunolocalization experiment confirmed the presence of the protein in the nucleus of immature embryos and aleurone cells and most predominantly in nucleoli (Stacy et al. 1999). The presence of these 1-Cys Prx was, however, also observed in the cytosol of these cells.

All the proteins of this type are not well biochemically characterized, and in particular the identity of the electron donor is not known, as it is generally replaced by the chemical reductant dithiothreitol *in vitro*. It will be thus of great interest to determine the nature of this donor.

The 1-Cys Prx gene is only expressed in seeds and belongs to a monogenic family (Stacy et al. 1996; Haslekas et al. 1998). The expression was shown to be spatially and temporally regulated. The transcripts increase in the aleurone layer and in the imbibed embryos of dormant seeds exclusively, which suggests a role for these Prx in the control of dormancy, as H<sub>2</sub>O<sub>2</sub> was found to be able to break the phenomenon of dormancy (Stacy et al. 1996). In addition, many steps of the germination process, such as the desiccation and imbibition, are critical because of the formation of ROS. As the 1-Cys Prx possess an *in vitro* peroxidase activity, another hypothesis is that the Prx protects the only two tissues which survive the desiccation step. Given that other seed antioxidants, such as superoxide dismutase and catalase, are found throughout the plant, the seed-specificity of the Prx suggests a key role for this enzyme in this tissue (Haslekas et al. 1998). To investigate the exact function of the 1-Cys Prx, transgenic tobacco plants constitutively overexpressing the rice 1-Cys Prx gene have been generated (Lee et al. 2000). The frequency of germination of these plants was similar to the control plant but the transgenic lines exhibited a higher resistance against oxidative stress, suggesting that the essential role of 1-Cys Prx is protection against oxidants.

### Monomeric type II Prx

A poplar Prx with two conserved cysteines is assumed to function as a 1-Cys Prx because site-directed mutagenesis has demonstrated that only the catalytic cysteine of the poplar Prx is essential for hydroperoxide reduction (Rouhier et al. 2002). Moreover, this enzyme is the only plant Prx so far characterized, that can accept both glutaredoxin (Grx) and thioredoxin as an electron donor (Rouhier et al. 2001). The only other biochemically characterized Prx of this group is from *Brassica rapa*, which was shown to be Trx dependent, but Grx was probably not tested (Choi et al. 1999). It will also be of interest to characterize the proteins of this class putatively routed to the chloroplast, in order to verify the specificity of the electron donor because no glutaredoxins have so far been found in the chloroplast. Additional informations about the Grx dependence of the Prx is provided by the numerous existing fusion sequences in the nucleotide databases between Grx and Prx modules and by the characterization of this type of protein in *Chromatium gracile* (Vergauwen et al. 2001).

### Perspectives

Different Prx isoforms have been characterized in several plant compartments such as the chloroplast, the nucleus and presumably the cytosol. Nevertheless, the increasing number of plant sequencing projects could well lead to the description of new plant Prx isoforms localized in the mitochondria or in the peroxisome, as already shown in mammals or in yeast (Knoops et al. 1999, Yamashita et al. 1999, Pedrajas et al. 1999). The presence of a complete thioredoxin system in plant mitochondria indicates that a functional electron donor system is present for any putative Prx present (Laloi et al. 2001). Interestingly, Dietz et al (2002) describe the existence in *Arabidopsis thaliana* of a sequence whose gene product is presumed to be mitochondrial.

One domain to explore in plants is related to the broad substrate specificities of Prx. Indeed, in addition to hydroperoxides, bacterial Prx have been demonstrated to be able to reduce different reactive nitrogen species, and particularly peroxynitrites, into nitrites (Chen et al. 1998, Bryk et al. 2000). Recently, a Prx from *Leishmania chagasi* was also found to detoxify hydroxyl radicals (Barr and Gedamu 2001). Moreover, a thioredoxin peroxidase from yeast was proposed to eliminate reactive sulfur species (Chae et al. 1994b)

Another challenge for plant Prx is to determine the *in vivo* functions of these proteins. Some indications provided by the studies in mammalian cells suggest that Prx are involved in cell differentiation and proliferation (Nemoto et al. 1990; Prosperi et al. 1993) and in apoptosis (Zhang et al. 1997; Kowaltowski et al. 2000; Berggren et al. 2001). All these functions seem to be linked to the antioxidative properties of the Prx.

### References

- Asada K (1999) The water-water cycle in chloroplasts: scavenging of active oxygen and dissipation of excess photons. *Annu Rev Plant Physiol Plant Mol Biol* 50: 601-639
- Baier M and Dietz KJ (1996) Primary structure and expression of plant homologues of animal and fungal thioredoxin-dependent peroxide reductases and bacterial alkyl hydroperoxide reductases. *Plant Mol Biol* 31: 553-564
- Baier M and Dietz KJ (1997) The plant 2-Cys peroxiredoxin BAS1 is a nuclear-encoded chloroplast protein: its expressional regulation, phylogenetic origin, and implications for its specific physiological function in plants. *Plant J* 12: 179-190
- Baier M and Dietz KJ (1999a) Protective function of chloroplast 2-cysteine peroxiredoxin in photosynthesis. Evidence from transgenic *Arabidopsis*. *Plant Physiol* 119: 1407-1414
- Baier M and Dietz KJ (1999b) Alkyl hydroperoxide reductases: the way out of the oxidative breakdown of lipids in chloroplasts. *Trends Plant Sci* 4: 166-168

- Baier M, Noctor G, Foyer CH and Dietz KJ (2000) Antisense suppression of 2-cysteine peroxiredoxin in Arabidopsis specifically enhances the activities and expression of enzymes associated with ascorbate metabolism but not glutathione metabolism. *Plant Physiol* 124: 823–832
- Barr SD and Gedamu L (2001) Cloning and characterization of three differentially expressed peroxidase genes from *Leishmania chagasi*. Evidence for an enzymatic detoxification of hydroxyl radicals. *J Biol Chem* 276: 34279–34287
- Berggren MI, Husbeck B, Samulitis B, Baker AF, Gallegos A and Powis G (2001) Thioredoxin peroxidase-1 (peroxiredoxin-1) is increased in thioredoxin-1 transfected cells and results in enhanced protection against apoptosis caused by hydrogen peroxide but not by other agents including dexamethasone, etoposide, and doxorubicin. *Arch Biochem Biophys* 2001 392: 103–109
- Bryk R, Griffin P and Nathan C (2000) Peroxynitrite reductase activity of bacterial peroxiredoxins. *Nature* 407: 211–215
- Chae HZ, Uhm TB and Rhee SG (1994a) Dimerization of thiol-specific antioxidant and the essential role of cysteine 47. *Proc Natl Acad Sci USA* 91: 7022–7026
- Chae HZ, Chung SJ and Rhee SG (1994b) Thioredoxin-dependent peroxide reductase from yeast. *J Biol Chem* 269: 27670–27678
- Chae HZ, Kim HJ, Kang SW and Rhee SG (1999) Characterization of three isoforms of mammalian peroxiredoxin that reduce peroxides in the presence of thioredoxin. *Diabetes Res Clin Pract* 45: 101–112
- Chen L, Xie QW and Nathan C (1998) Alkyl hydroperoxide reductase subunit C (AhpC) protects bacterial and human cells against reactive nitrogen intermediates. *Mol Cell* 1: 795–805
- Cheong NE, Choi YO, Lee KO, Kim WY, Jung BG, Chi YH, Jeong JS, Kim K, Cho MJ and Lee SY (1999) Molecular cloning, expression, and functional characterization of a 2Cys-peroxiredoxin in Chinese cabbage. *Plant Mol Biol* 40: 825–834
- Choi YO, Cheong NE, Lee KO, Jung BG, Hong CH, Jeong JH, Chi YH, Kim K, Cho MJ and Lee SY (1999) Cloning and expression of a new isotype of the peroxiredoxin gene of Chinese cabbage and its comparison to 2Cys-peroxiredoxin isolated from the same plant. *Biochem Biophys Res* 258: 768–771
- Dietz KJ, Horling F, König J and Baier M (2002) The function of the chloroplast 2-cysteine peroxiredoxin in peroxide detoxification and its regulation. *J Exp Bot* 53: 1321–1329
- Foyer CH and Noctor G (2000) Oxygen processing in photosynthesis: regulation and signalling. *New Phytol* 146: 359–388
- Genot G, Wintz H, Houlé G and Jamet E (2001) Molecular characterization of a bean chloroplast 2-Cys peroxiredoxin. *Plant Physiol Biochem* 39: 449–459
- Goyer A, Haslekas C, Miginiac-Maslow M, Klein U, Le Marchal P, Jacquot JP and Decottignies P (2002) Isolation and characterization of a thioredoxin-dependent peroxidase from *Chlamydomonas reinhardtii*. *Eur J Biochem* 269: 272–282
- Halliwel B and Gutteridge JM (1990) Role of free radicals and catalytic metal ions in human disease: an overview. *Methods Enzymol* 186: 1–85
- Haslekas C, Stacy RA, Nygaard V, Cullanez-Macia FA and Aalen RB (1998) The expression of a peroxiredoxin antioxidant gene, AtPer1, in *Arabidopsis thaliana* is seed-specific and related to dormancy. *Plant Mol Biol* 36: 833–845
- Herbette S, Lenne C, Leblanc N, Julien JL, Drevet JR and Roeckel-Drevet P (2002) Two GPX-like proteins from *Lycopersicon esculentum* and *Helianthus annuus* are antioxidant enzymes with phospholipid hydroperoxide glutathione peroxidase and thioredoxin peroxidase activities. *Eur J Biochem* 269: 2414–2420
- Horling F, Baier M and Dietz KJ (2001) Redox-regulation of the expression of the peroxide-detoxifying chloroplast 2-cys peroxiredoxin in the liverwort *Riccia fluitans*. *Planta* 214: 304–313
- Jeong W, Cha MK and Kim IH (2000) Thioredoxin-dependent hydroperoxide peroxidase activity of bacterioferritin comigratory protein (BCP) as a new member of the thiol-specific antioxidant protein (TSA)/Alkyl hydroperoxide peroxidase C (AhpC) family. *J Biol Chem* 275: 2924–2930
- Jung BG, Lee KO, Lee SS, Chi YH, Jang HH, Kang SS, Lee K, Lim D, Yoon SC, Yun DJ, Inoue Y, Cho MJ and Lee SY (2002) A Chinese cabbage cDNA with high sequence identity to phospholipid hydroperoxide glutathione peroxidases encodes a novel isoform of thioredoxin-dependent peroxidase. *J Biol Chem* 277: 12572–12578
- Kang SW, Chae HZ, Seo MS, Kim K, Baines IC and Rhee SG (1998) Mammalian peroxiredoxin isoforms can reduce hydrogen peroxide generated in response to growth factors and tumor necrosis factor- $\alpha$ . *J Biol Chem* 273: 6297–6302
- Klughammer B, Baier M and Dietz KJ (1998) Inactivation by gene disruption of 2-cysteine-peroxiredoxin in *Synechocystis* sp. PCC 6803 leads to increased stress sensitivity. *Physiol Plant* 104: 699–706
- Knoops B, Clippe A, Bogard C, Arsalane K, Wattiez R, Hermans C, Duconseille E, Falmagne P and Bernard A (1999) Cloning and characterization of AOEB166, a novel mammalian antioxidant enzyme of the peroxiredoxin family. *J Biol Chem* 274: 30451–30458
- Kong W, Shiota S, Shi Y, Nakayama H and Nakayama K (2000) A novel peroxiredoxin of the plant *Sedum lineare* is a homologue of *Escherichia coli* bacterioferritin co-migratory protein (Bcp). *Biochem J* 351: 107–114
- König J, Baier M, Horling F, Kahmann U, Harris G, Schurmann P and Dietz KJ (2002) The plant-specific function of 2-Cys peroxiredoxin-mediated detoxification of peroxides in the redox-hierarchy of photosynthetic electron flux. *Proc Natl Acad Sci USA*. 99: 5738–5743
- Kowaltowski AJ, Vercesi AE, Rhee SG and Netto LE (2000) Catalases and thioredoxin peroxidase protect *Saccharomyces cerevisiae* against Ca(2+)-induced mitochondrial membrane permeabilization and cell death. *FEBS Lett* 473: 177–182
- Laloi C, Rayapuram N, Chartier Y, Grienemberger JM, Bonnard G and Meyer Y (2001) Identification and characterization of a mitochondrial thioredoxin system in plants. *Proc Natl Acad Sci USA* 98: 14144–14149
- Lee KO, Jang HH, Jung BG, Chi YH, Lee JY, Choi YO, Lee JR, Lim CO, Cho MJ and Lee SY (2000) Rice 1Cys-peroxiredoxin overexpressed in transgenic tobacco does not maintain dormancy but enhances antioxidant activity. *FEBS Lett* 486: 103–106
- Lee SP, Hwang YS, Kim YJ, Kwon KS, Kim HJ, Kim K and Chae HZ (2001) Cyclophilin binds to peroxiredoxins and activates its peroxidase activity. *J Biol Chem* 276: 29826–29832
- Lewis ML, Miki K and Ueda T (2000) FePer 1, a gene encoding an evolutionarily conserved 1-Cys peroxiredoxin in buckwheat (*Fagopyrum esculentum* Moench), is expressed in a seed-specific manner and induced during seed germination. *Gene* 246: 81–91
- Montemartini M, Nogoceke E, Singh M, Steinert P, Flohe L and Kalisz HM (1998) Sequence analysis of the trypanoxin peroxidase gene from *Crithidia fasciculata* and its functional expression in *Escherichia coli*. *J Biol Chem* 273: 4864–4871
- Motohashi K, Kondoh A, Stumpp MT and Hisabori T (2001) Comprehensive survey of proteins targeted by chloroplast thioredoxin. *Proc Natl Acad Sci USA* 98: 11224–11229

- Mullineaux PM, Karpinski S, Jimenez A, Cleary SP, Robinson C and Creissen GP (1998) Identification of cDNAs encoding plastid-targeted glutathione peroxidase. *Plant J* 13: 375–379
- Nemoto Y, Yamamoto T, Takada S, Matsui Y and Obinata M (1990) Antisense RNA of the latent period gene (MER5) inhibits the differentiation of murine erythroleukemia cells. *Gene* 91: 261–265
- Noctor G and Foyer CH (1998) Ascorbate and glutathione: keeping active oxygen under control. *Annu Rev Plant Physiol Plant Mol Biol* 49: 249–279
- Pedrajas JR, Kosmidou E, Miranda-Vizuete A, Gustafsson JA, Wright AP and Spyrou G (1999) Identification and functional characterization of a novel mitochondrial thioredoxin system in *Saccharomyces cerevisiae*. *J Biol Chem* 274: 6366–6373
- Poole LB (1996) Flavin-dependent alkyl hydroperoxide reductase from *Salmonella typhimurium*. 2. Cystine disulfides involved in catalysis of peroxide reduction. *Biochemistry* 35: 65–75
- Prosperi MT, Ferbus D, Karczynski I and Goubin G (1993) A human cDNA corresponding to a gene overexpressed during cell proliferation encodes a product sharing homology with amoebic and bacterial proteins. *J Biol Chem* 268: 11050–11056
- Reynolds CM, Meyer J and Poole LB (2002) An NADH-dependent bacterial thioredoxin reductase-like protein in conjunction with a glutaredoxin homologue form a unique peroxiredoxin (AhpC) reducing system in *Clostridium pasteurianum*. *Biochemistry* 41: 1990–2001
- Rouhier N, Gelhaye E, Sautière PE, Brun A, Laurent P, Tagu D, de Fay E, Meyer Y and Jacquot JP (2001) Isolation and characterization of a new peroxiredoxin from poplar sieve tubes that uses either glutaredoxin or thioredoxin as a proton donor. *Plant Physiol* 127: 1299–1309
- Rouhier N, Gelhaye E and Jacquot JP (2002) Glutaredoxin-dependent Peroxiredoxin from Poplar. Protein–protein interaction and catalytic mechanism. *J Biol Chem* 277: 13609–13614
- Seo MS, Kang SW, Kim K, Baines IC, Lee TH and Rhee SG (2000) Identification of a new type of mammalian peroxiredoxin that forms an intramolecular disulfide as a reaction intermediate. *J Biol Chem* 275: 20346–20354
- Shikanai T, Takeda T, Yamauchi H, Sano S, Tomizawa KI, Yokota A and Shigeoka S (1998) Inhibition of ascorbate peroxidase under oxidative stress in tobacco having bacterial catalase in chloroplasts. *FEBS Lett* 428: 47–51
- Stacy RA, Munthe E, Steinum T, Sharma B and Aalen RB (1996) A peroxiredoxin antioxidant is encoded by a dormancy-related gene, *Per1*, expressed during late development in the aleurone and embryo of barley grains. *Plant Mol Biol* 31: 1205–1216
- Stacy RA, Nordeng TW, Cullianez-Macia FA and Aalen RB (1999) The dormancy-related peroxiredoxin anti-oxidant, *PER1*, is localized to the nucleus of barley embryo and aleurone cells. *Plant J* 19: 1–8
- Vergauwen B, Pauwels F, Jacquemotte F, Meyer TE, Cusanovich MA, Bartsch RG and Van Beeumen JJ (2001) Characterization of glutathione amide reductase from *Chromatium gracile*. Identification of a novel thiol peroxidase (Prx/Grx) fueled by glutathione amide redox cycling. *J Biol Chem* 276: 20890–20897
- Yamashita H, Avraham S, Jiang S, London R, Van Veldhoven PP, Subramani S, Rogers RA and Avraham H (1999) Characterization of human and murine PMP20 peroxisomal proteins that exhibit antioxidant activity *in vitro*. *J Biol Chem* 274: 29897–29904
- Zhang P, Liu B, Kang SW, Seo MS, Rhee SG and Obeid LM (1997) Thioredoxin peroxidase is a novel inhibitor of apoptosis with a mechanism distinct from that of Bcl-2. *J Biol Chem* 272: 30615–30618



Les travaux récents sur les Prx de plante qui ne sont pas inclus dans l'article de synthèse précédent sont résumés dans cette partie.

Les Prx à 2 cystéines sont des protéines chloroplastiques impliquées dans la protection des membranes des thylakoides et semblent obtenir avec une efficacité variable leur pouvoir réducteur de différentes isoformes de Trx chloroplastiques, les Trx m, les Trx f, les Trx x ou une Trx-like protéine appelée CDSP32 (chloroplastic drought-induced stress protein of 32 kDa), vraisemblablement au travers du transfert d'électrons photosynthétique et de la ferrédoxine (Broin *et al.*, 2002 ; König *et al.*, 2002 ; Collin *et al.*, 2003). CDSP 32 est une protéine chloroplastique avec un module Trx actif en position C-terminale qui, comme son nom l'indique, est impliquée dans la réponse à différents stress oxydants et notamment à un stress hydrique sévère (Rey *et al.*, 1998 ; Broin *et al.*, 2000). L'attachement de la Prx à 2 cystéines aux membranes des thylakoides s'effectue suite à une oligomérisation de la protéine lorsqu'elle est réduite ou dans un état d'oxydation irréversible, en présence d'ascorbate ou de fortes concentrations en sels (König *et al.*, 2002 ; König *et al.*, 2003). Par ailleurs, cette Prx à 2 cystéines possède un large spectre de substrats allant du peroxyde d'hydrogène aux phospholipide hydroperoxydes en passant par des alkyl hydroperoxydes (König *et al.*, 2003). De plus, elle est capable de lutter contre les espèces nitrées réactives. Cette aptitude a été mise en évidence *in vivo* par des études de complémentation de souches de levures mutées au niveau des homologues cytosoliques des Prx à 2 cystéines (Tsa1 et Tsa2) et sensibles aux RNS. Cette capacité a été confirmée *in vitro* en suivant l'inhibition par cette Prx de l'oxydation de la dihydrorhodamine 123 par les peroxy-nitrites (Sakamoto *et al.*, 2003).

Un important travail de caractérisation des différentes isoformes de Prx exprimées chez *A. thaliana* a été réalisé. Au niveau biochimique, toutes les isoformes testées possèdent une activité de réduction du peroxyde d'hydrogène (Horling *et al.*, 2003). Par ailleurs, l'expression des différentes isoformes a été suivie au niveau des transcrits et des protéines en fonction des différents tissus et de leur âge, de stress salin ou oxydant, de l'alternance entre faible et forte intensité lumineuse ou d'un apport en ascorbate (Horling *et al.*, 2002 ; Horling *et al.*, 2003). Les résultats obtenus démontrent que parmi les isoformes chloroplastiques, les profils d'expression sont sensiblement identiques quels que soient les traitements réalisés, mais que les Prx, situées dans les différents compartiments cellulaires

semblent être régulées de manière différente. Par ailleurs, l'analyse du protéome de mitochondrie d'*A. thaliana* en réponse à des stress oxydant provoqués par le peroxyde d'hydrogène ou la ménadione indique que l'expression de la Prx IIF mitochondriale est augmentée plus de 3 fois (Sweetlove *et al.*, 2002).

Enfin, alors que toutes les Prx à 1 cystéine étudiées jusqu'à présent étaient localisées dans les noyaux des cellules des graines, une isoforme issue de *Xerophyta viscosa* est localisée dans les noyaux des cellules des tissus végétatifs et son expression est induite lors de divers stress abiotiques (Mowla *et al.*, 2002).

### 3.2 Les méthionine sulfoxyde réductases

Les méthionine sulfoxyde réductases végétales ont été très peu étudiées jusqu'à présent et de ce fait les données concernant ces enzymes sont rares. Je vais donc décrire dans ce chapitre les quelques informations existant chez les plantes et surtout détailler les résultats obtenus chez d'autres organismes.

Sous l'action de radicaux toxiques tels que le peroxyde d'hydrogène ( $H_2O_2$ ), les ions superoxydes ( $O_2^{\cdot-}$ ) et les radicaux hydroxyles ( $OH^{\cdot}$ ), la méthionine (Met) peut être oxydée en méthionine sulfoxyde (MetSO), phénomène réversible, ou en méthionine sulfone, a priori irréversiblement (Figure 4). La réduction des MetSO en Met est effectuée par des enzymes ubiquitaires appelées méthionine sulfoxyde réductases (Msr) ou peptide méthionine sulfoxyde réductases (pMSR). Ces enzymes sont capables de réduire les résidus MetSO libres ou intégrés dans les protéines. Elles nécessitent l'apport de pouvoir réducteur fourni par le système Trx (Russel & Model, 1986 ; Boschi-Muller *et al.*, 2001). La première mise en évidence de la fonction de ces enzymes a été réalisée à partir d'études sur une souche d'*Escherichia coli* (*E. coli*) auxotrophe pour la Met mais pouvant se développer en présence de MetSO (Ejiri *et al.*, 1979). Les auteurs ont pu vérifier qu'un type de Msr, appelé par la suite méthionine sulfoxyde réductase de type A (MsrA), était capable de réduire les MetSO en Met. Par la suite, le séquençage complet de certains génomes, de récentes études de stéréospécificité et la caractérisation de mutants MsrA ont mis en évidence l'existence d'un second type de Msr appelé MsrB (type B) (Grimaud *et al.*, 2001 ; Singh *et al.*, 2001).

#### 3.2.1 Les MsrA

##### 3.2.1.1 les différentes familles

Les MsrA sont des enzymes monomériques dont la masse moléculaire varie entre 25 et 35 kDa. La présence de cette enzyme a été démontrée aussi bien chez les eucaryotes que chez les eubactéries et les archéobactéries. La comparaison de séquences de MsrA permet de distinguer six sous-classes en fonction du nombre et de la position des cystéines conservées (Figure 11, Tableau IV). Les positions de

référence sont 51, 54, 198 et 206, selon la numérotation des cystéines de l'enzyme d'*E. coli*.

	POSITION DES CYSTEINES			
	51	54	198	206
<i>Escherichia coli</i> , <i>Bos taurus</i> , <i>Arabidopsis thaliana</i>	+	0	+	+
<i>Deinococcus radiodurans</i> , <i>Sulfolobus solfataricus</i>	+	+	+	0
<i>Neisseria meningitidis</i> , <i>Saccharomyces cerevisiae</i>	+	0	+	0
<i>Bacillus subtilis</i> , <i>Staphylococcus aureus</i>	+	+	0	0
<i>Rhodobacter capsulatus</i>	+	0	0	0
<i>Gracilaria gracilis</i>	+	0	0	+

Tableau IV : **Position des cystéines essentielles dans les différentes familles**

**de MsrA.** + : présence ; 0 : absence

Ec	1	-----MSLFDKHLVSPADALPGRNTPMPVATLHAVNG-HSM--TN	39
Ech	1	-----MIANFDKTQPIGQSDALPGRTPMPVARLHVVNQ-HSM--TH	39
Hs	1	MLSATRRACQLLLLHSLFPVPRMGNSASNIVSPQEALPGRKEQTPVAAKHHVNGNRTV--EP	60
Bt	1	MLSVTRRALQ--LFHSLFPIPRMGDSAIVSPQEALPGRKEPLVVAKHHVNGNRTV--EP	58
Os	1	-----MSWLGKLGGLGGSP-RASAASAALAQQPDE-----DR	33
At	1	-----MNILNKLIGIG---SSR-QTNMDPSPIAQVIDD-----EA	30
Dr	1	-----MGWHPLGEHGAPHNSSMTQQTNSQ-----G-----TQ	28
Ss	1	-----	
Sc	1	-----MSSLISKTIKY-----D	12
Nm	131	AQSLNISVYPSWALIGKGDVQRIVKGSINEAQALALIRDPNADLGLSKHSFYKPDQKKDS	193
Bs	1	-----	
Sa	1	-----	
Rc	1	-----MRRLVLALALALATPAFAEEFRVIPPAAVD-----AA	32
Gg	226	GSDDVHGLDARNELIPMLTSAASVSSPAATEVLSAEQQTETDTALPADVVSE-----EK	282

```

Ec      VPDGMEIAIFAMGCFWGVVERLFWQLPG--VYSTAAGYTGG---YTPNPT---YREVCSDTG  92
Ech    VPDHMEVAIFAMGCFWGVVERLFWQQPG--VYSTASGYCGG---YTPNPT---YREVCTGKTG  93
Hs     FPEGTQMAVFGMGCFWGAERKFWVLKG--VYSTQVGFAGG---YTSNPT---YKEVCSEKTG  114
Bt     FPEGTQMAVFGMGCFWGAERKFWTLKG--VYSTQVGFAGG---YTPNPT---YKEVCSGKTG  112
Os     PAAGNEFAQFGAGCFWGVVELAFQRVPG--VTRTEVGYSSQG---NLHDPT---YEDVCTGATY  87
At     PAPGNQFTQFGAGCFWSVELAYQRVPG--VTQTEVGYSSQG---ITHDPS---YKDVCSGTTN  84
Dr     PGAAQEQAIFAGGCFWCTEAVMQDLRG--VQKVESGYIGG---TVPNPD---YRSVCGGQTG  81
Ss     ----MEVATLGGGCFWCTEAVYKRVKG--VISVKPGYSSG---HVPNPT---YEDVCTDTTG  50
Sc     P-AKDKLITLACGCFWGTTEHMYRKYLNDRIVDCKVGYANGEESSKKDSPSSVSYKRVCGDTD  73
Nm     KIMNTRTIYLAGGCFWGLEAYFQRIDG--VVDVAVSGYANG---NTKNPS---YEDVSYRHTG  247
Bs     MSEKKEIATFAGGCFWCMVKPFDEQPG--IEKVVSQYTG---HTENPT---YEEVCSETTG  54
Sa     --MTKEYATLAGGCFWCMVKPFTSYPG--IKSVVSGYSSG---HVDNPT---YEQVCTNQTG  52
Rc     ALTGPETAIFAGGCFWGVQGVFQHLNG--VISATSGYAGG---TAATAH---YDQVSGGETG  86
Gg     PKTETKEIVFGAGCFWGVVELAFQRVAG--VLKTEVGYSSG---KMSRVT---YDAICTGATG  335

```

\*\*\*\* \* \*

```

Ec      HAEAVRIVYDPSVISYEQLLQVFWEN-HDPAQGMROGNDHGTQYRSAIYPLTPEQDAAARAS  153
Ech    HAEAVRVVFDPAVVSYPQLLQLFWEN-HNPAQGMROGNDIGTQYRSAIYTLTTEQETAAKES  154
Hs     HAEVVRVVYQPEHMSFEELLKVFWEW-HDPTQGMROGNDHGTQYRSAIYPTSAKQMEAAALSS  175
Bt     HAEVVRVVYQPEHISFEELLKVFWEW-HDPTQGMROGNDHGSQYRSAIYPTSAEHVGAALKS  173
Os     HNEVVRVHYDVSACKFDDLLDVFWAR-HDPTTPNRQGNVGTQYRSGIYIYPTPEQEKAAARES  148
At     HAEIVRVQYDPKCESYQSLLDLFWSK-HDPTTLNRQGNVGTQYRSGIYFYNPPEQEKLARES  145
Dr     HAEAVRVTFDPNQISYRDLLGLFFAT-HDPTSLNRQGNVGTQYRSALFPLTQEQEQTAREM  142
Ss     HAEVVQITFDSSIIISYREILEIFFEII-HDPTTLNRQGNVGTQYRSIILYHNEEQRKIAEEM  111
Sc     FAEVLQVSYNPKVITLRELTFDFFRRI-HDPTTNSQGPDKGTQYRSGLFAHSDADLKLAKI  134
Nm     HAETVKVITYDADKLSLDDILQYFFRV-VDPTSLNKQGNVGTQYRSGVYITDPAEKAVIAAA  308
Bs     HREAVQITFHPDVFPYEKLELFWQQ-IDPTDAGGQFADRGSSYRAAIFYHNDKQKELAEAS  115
Sa     HVEAVQITFDPEVTSFENILDIYFKT-FDPTDDQGFDRGESYQPVIFYHDEHQKAAEFK  113
Rc     HAEAVQVVFDPKQISYGDLLQVFFSVAHDPTQLNRQGNVGTQYRSALFPVTFEDQARIAKAY  148
Gg     SAEVVRVWYDPSVLFKQLLEVWESR-HDPTSLNKQGNVGTQYRSAIYYSDEEQAEVRRW  396

```

\* \* \* \* \*

```

Ec      LERFQAAMLAADDDRHITEIANATPFYYAEDDHQOYLHKNPY-GYCGIGGIGVCLPPEA--  212
Ech    YQRFQQAMRDAGNDHDITTEIQPAGPFYYAEDEHQOYLHKNPD-GYCGLGGIGVCLPQQ--  213
Hs     KENYQKVLSEHGFG-PITTDIREGQTFYYAEDYHQOYLSKNPN-GYCGLGGTGVSCPLGIKK  235
Bt     KEDYQKVLSEHGFG-LITTDIREGQTFYYAEDYHQOYLSKDPD-GYCGLGGTGVSCPLGIKK  233
Os     LEKQQK----L-LNRTIVTEILPAKRFYRAEEYHQOYLAKGGRFGFRQSAEKGNDPIRQY  205
At     LERHQQ----Q-VDRKVVTEILPAKRFYRAEEHHQOYLSKGRFGLKQSTKGNNDPIRQY  202
Dr     IEQLGT---EDVFGRPVITSIEPASTFYVAEDYHQNYKNNPGQGYCMAVISPKVAKLRQY  201
Ss     IREV-----EKRIGKVVTELKPFYEAEDYHDFYDKHKYNPYCRLLVISPVKKFMKLF  168
Sc     KEEWQP----K-WGNKIATVIEPIKNFYDAEEYHQYLDKNPQGYACPTHYLRM-----  184
Nm     LKREQQ----K-YQLPLVENEPLKNFYDAEEYHQDYLIKNNPN-GYCHIDIRKADEPLPGKT  364
Bs     KQRLAE---SGIFKDPVTDILKAEPFYEAEGYHQHFYKKNPAHYQRYRTGSGRAGFISEHW  174
Sa     KQQLNE---QGIFKPVITPIKPYKNFYPAEDYHQDYKKNPVHYYQYQYRQSGRKAFLSEHW  172
Rc     IDQLGR---ARAFDAAIVTQLDPAAFYPAEAYHQNFLTLNPDHPYIVQVDMPKIAALERMF  207
Gg     ISEAST----R-HTKEIVTEVAAIKNYCAEEYHQRYLEKKG-----QSAEKGSSASIRQY  448

```

\*\* \*

```

Ec      ----- 212
Ech    ----- 213
Hs     ----- 235
Bt     ----- 233
Os     ----- 205
At     ----- 202
Dr     GDKLR----- 206
Ss     PDKVKIHEG----- 177
Sc     ----- 184
Nm     KTAPQGGKGFDAATYK 379
Bs     GAK----- 177
Sa     GNQNA----- 177
Rc     PQDWREVPVLLPVAD 222
Gg     ----- 448

```

**Figure 11 : Alignement des 6 sous-classes de MsrA.**

Rc : *Rhodobacter capsulatus*, Bs : *Bacillus subtilis*, Sa : *Staphylococcus aureus*, Dr : *Deinococcus radiodurans*, Ss : *Sulfolobus solfataricus*, Ec : *Escherichia coli*, Ech : *Erwinia chrysanthemi*, Hs : *Homo sapiens*, Bt : *Bos taurus*, Os : *Oryza sativa*, At : *Arabidopsis thaliana*, Gg : *Gracilaria gracilis*, Sc : *Saccharomyces cerevisiae*, Nm : *Neisseria meningitidis*. Les séquences d'*H. sapiens*, *E. chrysanthemi* et *O. sativa* ne sont pas reportées dans le tableau IV mais appartiennent au groupe 1. Les astérisques correspondent aux acides aminés conservés. Les cystéines en fond gris représentent les cystéines en position conservée à l'intérieur de chaque sous-classe (numérotation d'*E. coli* : 51, 54, 198 et 206) et susceptibles de participer au mécanisme catalytique.

Le premier type est représenté par les MsrA d'*E. coli* et de mammifères qui possèdent les trois cystéines catalytiques 51, 198 et 206, mais pas la cystéine 54. Ce groupe renferme la plupart des MsrA d'origine végétale même si elles diffèrent d'une part en position C-terminale par la nature des acides aminés environnant les deux cystéines (absence dans les séquences végétales des nombreuses glycines) et d'autre part par la présence de seulement 5 acides aminés entre ces deux cystéines au lieu de 7 pour l'enzyme d'*E. coli*. Une deuxième sous-classe représentée entre autres par la protéine de *Deinococcus radiodurans*, ne possède pas la cystéine 206, mais présente les cystéines 51, 54 et 198. Les enzymes identiques à celle de *Saccharomyces cerevisiae* ne possèdent pas cette fois les cystéines 54 et 206, et pourraient donc former un autre groupe. La protéine PILB de *Neisseria meningitidis* est incluse dans ce groupe bien que possédant un module MsrB en fusion et une extension N-terminale. Un quatrième type de MsrA est représenté par l'enzyme de *Bacillus subtilis* qui ne possède pas les cystéines 198 et 206, mais comporte les 2 résidus en position 51 et 54. Une cinquième classe représentée par une séquence putative de *Rhodobacter capsulatus*, possède uniquement la cystéine 51. Enfin, l'enzyme de l'algue rouge *Gracilaria gracilis* est particulière non seulement parce qu'elle est fusionnée à deux modules Grx en position N-terminale, mais aussi parce qu'elle ne possède que les cystéines 51 et 206, mais pas les cystéines 54 et 198.

Cette comparaison permet également d'identifier, outre les cystéines catalytiques, un certain nombre de résidus essentiels. Ainsi, toutes les enzymes

présentent une séquence consensus conservée de type GCFW autour de la première cystéine catalytique du site actif. La substitution de chacun de ces acides aminés, excepté de la glycine, dans la MsrA de *S. cerevisiae* entraîne une perte totale d'activité de l'enzyme (Moskovitz *et al.*, 2000). Enfin, certaines MsrA de mammifères possèdent une extension N-terminale de 23 acides aminés qui dirige la protéine vers les mitochondries (Figure 11) (Hansel *et al.*, 2002).

### 3.2.1.2 La structure

Actuellement, les seules structures obtenues, par cristallographie aux rayons X, sont celles des enzymes d'*E. coli* et de *Bos taurus* (Tete-Favier *et al.*, 2000 ; Lowther *et al.*, 2000). Le cœur de l'enzyme est composé d'un feuillet  $\beta$  composé de 8 brins, entouré de 4 hélices  $\alpha$ . Les parties N et C-terminales de l'enzyme de *B. taurus* ne sont pas structurées (Figure 12). La cystéine catalytique 72 est exposée et accessible au substrat (numérotation de l'enzyme de *B. taurus*). Les cystéines 72 et 218 sont distantes de 8,6Å et les cystéines 218 et 227 de 21Å. Ces distances ne sont pas compatibles avec la formation de ponts disulfures à moins d'importants réarrangements conformationnels.

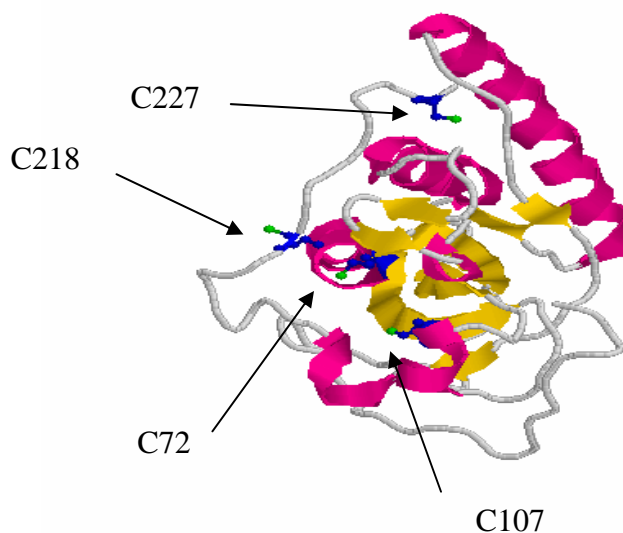

Figure 12 : **Structure tridimensionnelle de la MsrA de *B. taurus* (1FVA)** (Lowther *et al.*, 2000). La séquence est visualisée grâce au logiciel RasMol. Les hélices  $\alpha$  sont représentées en rose, les brins  $\beta$  en jaune et les cystéines et leur atome de soufre en bleu et vert respectivement.

### 3.2.1.3 Le mécanisme catalytique

Des études parallèles réalisées sur la MsrA d'*E. coli* et sur la MsrA de *B. taurus* ont conduit les différents auteurs à proposer un mécanisme sensiblement identique, mais présentant tout de même une différence lors de la première étape de catalyse, à savoir la formation ou pas d'un SOH.

La MsrA d'*E. coli* possède quatre résidus cystéine en position 51, 86, 198, et 206. Les cystéines 51, 186 et 206 sont impliquées dans l'activité de réduction Trx dépendante de la MetSO en Met alors que la cystéine 86 ne l'est pas mais pourrait jouer un rôle dans la formation de dimères (Boschi-Muller *et al.*, 2000 ; Boschi-Muller *et al.*, 2001). Le mécanisme réactionnel est présenté en Figure 13.

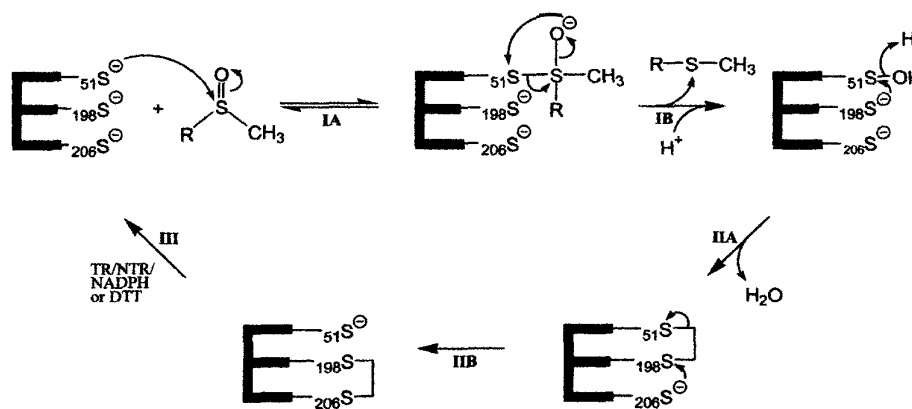

Figure 13 : **Mécanisme catalytique de la MsrA d'*E. coli*** (d'après Boschi-Muller *et al.*, 2001). Les trois étapes majeures de la réduction de la MetSO sont détaillées dans ce paragraphe.

La forme thiolate de la cystéine 51 attaque l'atome de soufre de la MetSO aboutissant, via un réarrangement, à la formation d'un SOH intermédiaire au niveau de cette cystéine et libère une mole de Met. Le SOH est ensuite réduit via la



formation d'un pont disulfure entre les cystéines 51 et 198, suivi par la formation d'un second pont disulfure entre les cystéines 198 et 206, libérant la cystéine 51, à nouveau libre pour l'attaque d'une deuxième molécule de MetSO. Le pont disulfure entre les cystéines 198 et 206 est ensuite réduit par les Trx. Ainsi, pour une mole d'enzyme, deux moles de MetSO sont réduites en Met, puisque la cystéine peut effectuer une seconde attaque nucléophile, corroborant les observations issues de l'étude des mutants monocystéiniques obtenus par mutagenèse dirigée. En effet, aucune mole de Met n'est formée avec le mutant C51S dans lequel la cystéine est mutée en sérine et une seule mole de Met est formée avec les mutants C198S et C206S au lieu des deux attendues dans le cas de la protéine sauvage. Les auteurs qui ont travaillé sur la MsrA de *B. taurus* proposent un mécanisme catalytique légèrement différent dans lequel un pont disulfure intermédiaire entre la cystéine 72, équivalente à la cystéine 51 d'*E. coli*, et la MetSO est formé et non pas un SOH (Lowther *et al.*, 2000).

### 3.2.2 Les MsrB

#### 3.2.2.1 les différentes familles

Les MsrB sont des enzymes de masse moléculaire de l'ordre de 12 à 15 kDa présentes chez tous les organismes. Chez les vertébrés, les MsrB sont plus connues sous le nom de SelR ou SelX, du fait de la présence d'un résidu sélénocystéine dans la partie C-terminale à la place d'une des cystéines catalytiques (Kryukov *et al.*, 2002). La présence de cette sélénocystéine dans les enzymes de mammifère est essentielle à leur activité et son remplacement par une cystéine diminue énormément leur efficacité catalytique (Bar-Noy & Moskovitz, 2002). Ces enzymes ne possèdent pas d'identité de séquence avec les MsrA. L'alignement de diverses séquences de MsrB permet de répartir ces enzymes selon 5 sous-groupes en fonction d'une part de la présence d'un résidu sélénocystéine ou d'un à 2 résidus cystéinyles et d'autre part de la présence ou l'absence de 2 motifs CxxC permettant la fixation d'un atome de zinc (Figure 14 et Tableau V). Des études récentes sur la MsrB de *Drosophila melanogaster* ont montré que la mutation d'une de ces cystéines ne permet plus la fixation d'un atome de zinc, et entraîne également une perte d'activité de l'enzyme (Kumar *et al.*, 2002). Dans ce type de protéine, le zinc jouerait un rôle de stabilisateur de la structure protéique.

	C74	C128	U128	PRESENCE DE ZINC
<i>Homo sapiens</i> SEL X, <i>Mus musculus</i> SEL R	0	0	+	+
<i>Escherichia coli</i> , <i>Drosophila melanogaster</i>	+	+	0	+
<i>Rhodobacter sphaeroides</i> <i>Pseudomonas aeruginosa</i>	0	+	0	+
<i>Bacillus halodurans</i> <i>Clostridium acetobutylicum</i>	+	+	0	0
<i>Legionella pneumophila</i> , <i>Pseudomonas europae</i>	0	+	0	0

Tableau V : Les 5 sous-groupes de MsrB.

Cette classification est basée sur la présence ou l'absence des cystéines 74 et 128 ou de la sélénocystéine 128 (U128) (numérotation d'*E. coli*) et des motifs de fixation du zinc.

Le premier groupe renferme des sélénoprotéines trouvées chez les mammifères. Ce sont des protéines à zinc avec une sélénocystéine comme seul résidu catalytique. Un autre groupe, formé notamment des protéines d'*E. coli* et de *D. melanogaster*, possède les cystéines 74 et 128 et un atome de zinc. Les protéines du troisième groupe possèdent également un atome de zinc, la cystéine 128 mais pas la cystéine 74. La quatrième catégorie de MsrB, incluant l'enzyme de *Bacillus halodurans*, renferme les 2 cystéines mais pas de zinc. Enfin, les enzymes de la dernière classe, retrouvée chez *Pseudomonas europae*, ne présentent que la Cys128.

```

Homo s SEL X      1 -----
Mus m SEL R      1 -----
Escherichia c    1 -----MSTIKVRCEQMANKPS 16
Drosophila m     1 -----MDNKSEKVTVN 11
Rhodobacter s    1 -----MTDEREKVVKS 11
Pseudomonas a    1 -----MSKIDKP- 7
Clostridium a    1 -----MK 2
Bacillus h       1 -----MTEQ 4
Legionella_p     1 -----MTKLISVVFYLFIIIPNVMA YTPQFN 25
Pseudomonas e 301 IPMVATKNTNPPADWTLDKPLFAAPTIVL FREGKEVVRYTGYTG EKENFW 351

```



### 3.2.2.2 La structure

D'un point de vue structural, seule la structure tridimensionnelle d'un motif MsrB appartenant à un facteur de virulence de *Neisseria gonorrhoeae* nommé PILB, a pu être résolue (Figure 15) (Lowther *et al.*, 2002). Le cœur de l'enzyme est formé de deux feuillets  $\beta$  anti-parallèles, qui sont entourés de 3 hélices  $\alpha$  et de 5 hélices  $3_{10}$ . Une triade catalytique essentielle est composée de la cystéine 495, de l'arginine 493 et de l'aspartate 484. Les groupements thiols des 2 cystéines en position 440 et 495 se font face et sont distants de 2,96 à 3,25 Å, distance beaucoup plus favorable pour la formation d'un pont disulfure que celle séparant les cystéines des MsrA.

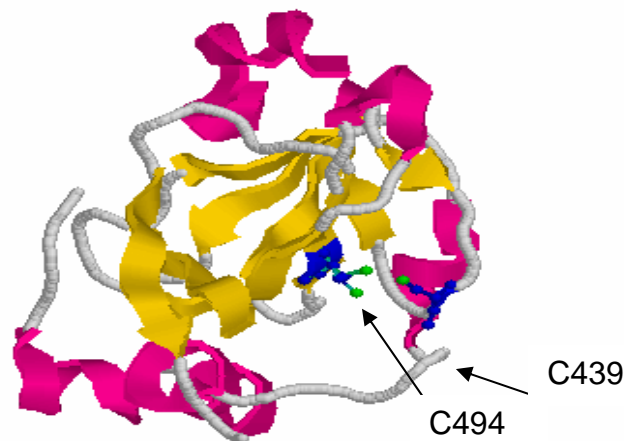

Figure 15 : **Structure tridimensionnelle du motif MsrB de la protéine PILB de *N. gonorrhoeae* (1L1D) (Lowther *et al.*, 2002).**

Il existe deux positions spatiales différentes pour le groupement thiol de la cystéine 494 qui reflètent l'état de la protéine dans les cristaux. La représentation utilisée est la même que celle utilisée pour la Figure 12.

### 3.2.2.3 Le mécanisme catalytique

Les MsrB ont un mécanisme catalytique similaire aux MsrA, avec la formation transitoire d'un SOH mais qui ne fait intervenir généralement que 2 cystéines alors

que 3 cystéines sont essentielles pour les MsrA (Boschi-Muller *et al.*, 2000 ; Kumar *et al.*, 2002 ; Olry *et al.*, 2002).

Chez *N. meningitidis*, le motif MsrB du polypeptide PILB possède deux cystéines en position 439 et 494, impliquées dans la réduction de la MetSO (Olry *et al.*, 2002). Ces cystéines sont équivalentes aux cystéines 69 et 124 de la MsrB de *D. melanogaster* (Kumar *et al.*, 2002). La différence notable entre les deux enzymes est l'absence dans l'enzyme de *N. meningitidis* des cystéines pour la fixation du zinc. Le mécanisme réactionnel, identique pour ces deux protéines, est présenté en Figure 16. Pour les MsrB ne possédant pas l'équivalent de la cystéine 69 ou 439, il semble que l'acide sulfénique soit directement attaqué par la Trx (Jung *et al.*, 2002b).

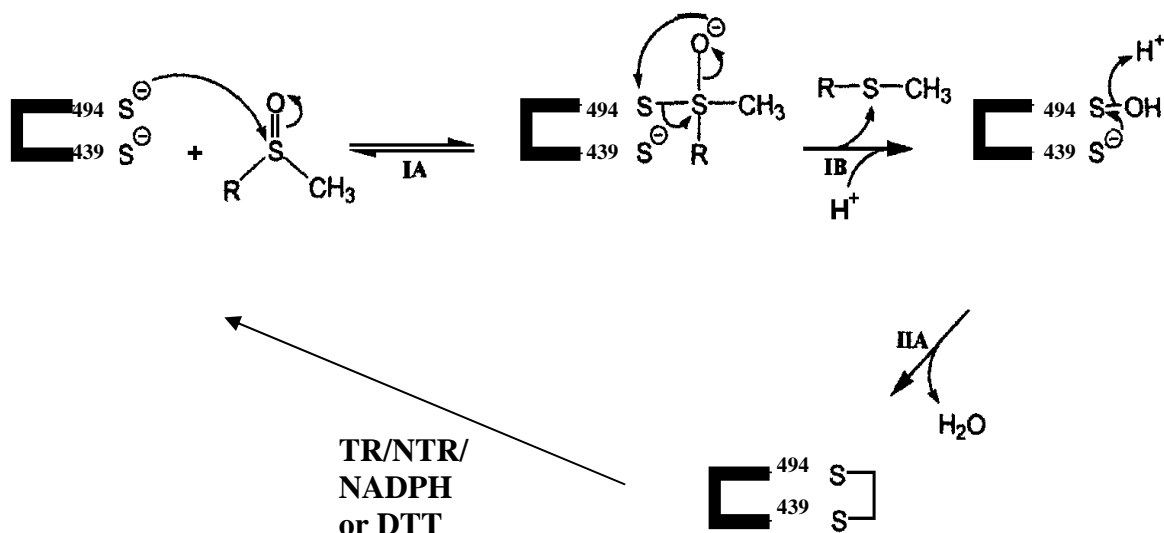

Figure 16 : **Mécanisme catalytique du motif MsrB de la protéine PILB de *N. meningitidis*** (d'après Olry *et al.*, 2002).

Dans cet exemple, la forme thiolate de la cystéine 494 attaque l'atome de soufre de la MetSO pour former un SOH intermédiaire et libérer une mole de Met. Ce SOH est à son tour attaqué par la cystéine 439 aboutissant à la formation d'un pont disulfure entre les cystéines 439 et 494. Ce pont disulfure sera ensuite réduit par les Trx, permettant de réactiver l'enzyme. Ce mécanisme semble être applicable à une grande majorité de MsrB.

Cependant, les comparaisons de séquences indiquent notamment que la MsrB humaine hCBS1 ne possède pas la seconde cystéine catalytique dans une position conservée, mais que celle-ci se trouve en position légèrement décalée. La mutation de cette cystéine n'influence pas l'activité de l'enzyme au contraire de celle de la cystéine d'attaque en position 169, équivalent à la cystéine 494 de PILB (Jung *et al.*, 2002b). Ces travaux suggèrent que cette enzyme fonctionne selon un mécanisme catalytique différent des autres MsrB, vraisemblablement par la réduction du SOH directement par les Trx. Cette hypothèse est renforcée par l'existence de nombreuses séquences qui ne possèdent pas la cystéine équivalente à celle située en position 494 de PILB ou 69 de la protéine de *D. melanogaster* (voir § 3.2.2.1).

### 3.3 La réduction des MetSO libres

L'oxydation chimique de l'atome de soufre asymétrique de la méthionine produit deux épimères de MetSO, les formes R ou S, qu'elles soient libres ou intégrées dans un polypeptide. Les MsrA et la fMSr, une enzyme spécifique des formes libres de la MetSO, sont capables de réduire l'énantiomère libre S-MetSO mais pas la R-MetSO (Moskovitz *et al.*, 1996a). De plus, les MsrB ont une activité très faible envers la R-MetSO dans des extraits d'*E. coli* et la forme libre R-MetSO est un mauvais substrat *in vitro* pour cette enzyme, suggérant l'existence d'enzymes spécifiques pour cette réduction (Grimaud *et al.*, 2001). L'utilisation de double mutants MsrA<sup>-</sup> et MsrB<sup>-</sup> d'*E. coli* a permis récemment de purifier partiellement une fRMSr et de mettre en évidence une activité de réduction de l'isomère R-MetSO libre (Etienne *et al.*, 2003). De plus, l'utilisation de ce mutant a aussi permis de caractériser au niveau membranaire une activité de réduction de la R ou S-MetSO libre ou intégrée dans des protéines (Spector *et al.*, 2003). Les séquences codant pour ces enzymes doivent être divergentes par rapport aux séquences existantes car le séquençage complet du génome d'*E. coli* n'a mis en évidence qu'une seule isoforme de MsrA et de MsrB (Kryukov *et al.*, 2002).

### 3.4 Expression et fonctions des méthionine sulfoxyde réductases

D'un point de vue fonctionnel, la caractéristique première des MsrA et MsrB est leur diastéréosélectivité envers les isomères R et S de la L-MetSO, l'isomère L

étant la forme unique de la MetSO *in vivo*. En effet, les MsrA ne réduisent que les isomères de type S et les MsrB les isomères de type R (Sharov *et al.*, 1999 ; Moskovitz *et al.*, 2002).

L'oxydation de la Met en MetSO est un phénomène connu pour être impliqué dans plusieurs pathologies telles que la maladie d'Alzheimer (Gabbita *et al.*, 1999) et pour exercer des effets régulateurs sur les protéines, modifiant leurs propriétés biologiques (pour revue voir Brot & Weissbach, 2000).

D'une part, ce phénomène peut conduire à une inhibition de l'activité de certaines protéines. C'est le cas par exemple de l'inhibiteur  $\alpha$ -protéinase, dont l'oxydation de résidus Met diminue l'affinité pour ses protéases cibles (Vogt *et al.*, 1995). De même, l'oxydation de certaines Met de la calmoduline induit des changements dans la structure tertiaire de la protéine qui entraîneraient une diminution de sa capacité à activer la Ca<sup>2+</sup>ATPase de la membrane plasmique (Yao *et al.*, 1996 ; Sun *et al.*, 1999).

D'autre part, l'oxydation de Met peut être une forme d'activation, c'est notamment le cas pour le composant C5 du complément. Ce composé est le point de départ de la formation du complexe d'attaque membranaire qui aboutira à la lyse de corps étrangers. L'oxydation de certaines Met par des radicaux hydroxyles active ce composant C5 (Vogt *et al.*, 1995). De plus, l'oxydation d'une Met en MetSO régule l'inactivation d'un canal potassique voltage dépendant (Ciorba *et al.*, 1997 ; Ciorba *et al.*, 1999).

Par ailleurs, l'oxydation et la réduction cyclique des résidus Met exposés à la surface des protéines serviraient de première ligne de défense anti-oxydante contre des dommages liés aux ROS et aux RNS (Moskovitz *et al.*, 1999 ; Levine *et al.*, 2000 ; St John *et al.*, 2001 ; Stadtman *et al.*, 2002). Ainsi, l'oxydation de plusieurs résidus Met n'altère pas par exemple l'activité de la glutamine synthétase (Levine *et al.*, 1999). De plus, l'étude de mutants MsrA<sup>-</sup> d'*E. coli*, d'*Erwinia chrysanthemi* et de levure a montré que ceux-ci étaient plus sensibles au stress oxydatif que les souches sauvages et par conséquent que les MsrA joueraient un rôle dans la résistance au stress oxydatif (Moskovitz *et al.*, 1995 ; Moskovitz *et al.*, 1997 ; Moskovitz *et al.*, 1998 ; Hassouni *et al.*, 1999). En luttant contre ce stress, les MsrA participeraient à l'augmentation de la durée de vie des organismes (Moskovitz *et al.*, 2001 ; Petropoulos *et al.*, 2001 ; Ruan *et al.*, 2002).

Les MsrA pourraient également être impliquées dans l'adhérence de certaines bactéries et donc dans leur pathogénicité. En effet, l'étude de mutants MsrA<sup>-</sup> de *Streptococcus pneumoniae* ou de *Mycoplasma genitalium* a démontré que ceux-ci se liaient moins facilement respectivement aux cellules épithéliales des poumons et des vaisseaux ou aux érythrocytes (Wizemann *et al.*, 1996 ; Dhandayuthapani *et al.*, 2001).

De plus, cette enzyme joue un rôle dans la virulence de certaines espèces pathogènes. Ainsi, la mutation du gène *msrA* du pathogène *E. chrysanthemi* fait perdre à la bactérie sa capacité à envahir la plante. Les auteurs supposent qu'un ou plusieurs résidus Met du facteur de virulence pourraient être oxydés. En absence de MsrA, il ne pourrait pas être réduit et cela limiterait la croissance de la bactérie dans la plante (Hassouni *et al.*, 1999). Un autre exemple est la protéine PILB de *N. gonorrhoeae* qui serait impliquée dans la virulence de cette bactérie (Taha *et al.*, 1991). Récemment, des études ont montré que cette protéine n'intervenait pas dans l'expression des pili, mais qu'elle serait impliquée dans la lutte contre les ROS grâce à sa localisation sur la membrane externe (Skaar *et al.*, 2002). Par contre, chez *Actinobacillus actinomycetemcomitans*, la délétion du gène *msrA* ne provoque pas de modification de l'adhérence des bactéries sur les cellules épithéliales (Mintz *et al.*, 2002). Les auteurs suggèrent qu'un autre système redondant pourrait compenser la perte de ce gène.

Enfin, l'expression du gène *msrA* d'*Enterococcus faecalis* est induite en réponse à un stress chimique ou dû aux métaux lourds (Laplace *et al.*, 2000 ; Tamburro *et al.*, 2001). Chez les mammifères, les *msrA* sont exprimées dans tous les tissus analysés même si l'expression est plus importante dans certains tissus (Moskovitz *et al.*, 1996b ; Kuschel *et al.*, 1999).

### 3.5 Les protéines de fusion

Enfin, outre la fusion existant chez *G. gracilis* entre 2 modules Grx et un module MsrA, il existe un certain nombre de séquences constituées par des fusions entre des modules MsrA et MsrB. Ainsi, la protéine PILB de *N. meningitidis* ou *N. gonorrhoeae* constitue une fusion entre un module MsrA suivi d'un autre module MsrB et présente en plus une extension N-terminale de fonction inconnue et dont la délétion ne modifie pas l'activité méthionine sulfoxyde réductase de la protéine (Olry



et al., 2002). Il existe également des séquences ordonnées inversement, avec un module MsrB en amont d'un module MsrA (Kryukov et al., 2002).

### 3.6 Les méthionine sulfoxyde réductases végétales

Au cours de ces dernières années, la mise en évidence et la caractérisation de différentes Msr ont progressé chez de nombreux organismes, bactéries et mammifères notamment. Par contre, chez les végétaux, seules quelques informations physiologiques ont été obtenues pour des MsrA d'*A. thaliana*. Le séquençage complet du génome d'*A. thaliana* révèle l'existence d'au moins 4 isoformes de MsrA et 8 de MsrB (Figures 17 et 18, Tableau VI).

	Numéros d'accèsion	Longueur	Localisation	Cystéines conservées
<b>MsrA</b>				
pMsrA	At4g25130	258	chloroplastique	C <sub>100</sub> C <sub>250</sub> C <sub>256</sub>
cMsrA I	At5g61640	202	cytosolique	C <sub>44</sub> C <sub>194</sub> C <sub>200</sub>
cMsrA II	At5g07470	202	cytosolique	C <sub>44</sub> C <sub>194</sub> C <sub>200</sub>
cMsrA III	At5g07460	218	?	C <sub>60</sub> C <sub>210</sub> C <sub>216</sub>
<b>MsrB</b>				
MsrB I	At4g04810	139	cytosolique	C <sub>69</sub> C <sub>122</sub>
MsrB II	At4g04830	139	cytosolique	C <sub>69</sub> C <sub>122</sub>
MsrB III	At4g21850	143	cytosolique	C <sub>76</sub> C <sub>129</sub>
MsrB IV	At4g21840	143	cytosolique	C <sub>75</sub> C <sub>128</sub>
MsrB V	At4g21830	144	cytosolique	C <sub>76</sub> C <sub>129</sub>
MsrB VI	At4g04840	153	cytosolique	C <sub>85</sub> C <sub>138</sub>
MsrB VII	At1g53670	153	cytosolique	C <sub>137</sub>
MsrB VIII	At4g04800	176	voies de sécrétion	C <sub>108</sub> C <sub>161</sub>

Tableau VI : **Les différentes MsrA et MsrB d'*A. thaliana*.**

Les localisations ne sont que des prédictions faites grâce aux programmes de prédiction (voir Tableau I). Les cystéines conservées présentées sont supposées faire partie du mécanisme catalytique par analogie aux mécanismes connus des MsrA ou des MsrB. pMsrA : MsrA plastidiale, cMsrA : MsrA cytosolique.





Aucune MsrB végétale n'a pour l'instant été caractérisée. Parmi les 8 séquences de MsrB d'*A. thaliana*, toutes possèdent les motifs CxxC capables de fixer un atome de zinc. MsrB III présente une extension N-terminale qui pourrait permettre la sécrétion de la protéine. Enfin, la MsrB VII possède la cystéine catalytique mais pas la deuxième cystéine conservée.

Concernant les MsrA, deux isoformes sur les 4 existant, une plastidiale et une cytosolique ont été étudiées. Ces deux protéines, exprimées chez *E. coli* et purifiées, présentent une activité de réduction des MetSO mais en présence d'un réducteur artificiel, le DTT (Sadanandom *et al.*, 1996 ; Sadanandom *et al.*, 2000). La MsrA chloroplastique possède une masse moléculaire de 28 kDa et un pH optimum de 8.0, en accord avec sa localisation stromatique. La MsrA cytosolique a pour sa part une masse moléculaire de 27 kDa et un pH optimum compris entre 7.0 et 7.2. Ces travaux démontrent également une forte expression de la forme cytosolique dans les racines et les graines et son implication dans la défense contre les pathogènes (Sadanandom *et al.*, 2000). La forme chloroplastique est fortement régulée par la lumière dans les tissus photosynthétiques et semble protéger l'activité chaperone d'une protéine heat shock (hsp21) en réduisant des MetSO en Met (Sadanandom *et al.*, 2000 ; Gustavsson *et al.*, 2002).

Enfin, une étude récente a montré l'existence de sélénoprotéines chez l'algue verte *Chlamydomonas reinhardtii*, alors que ce type de protéines n'était présent que chez les archéobactéries, les virus et les mammifères (Novoselov *et al.*, 2002). Parmi les 10 protéines identifiées se trouvent des protéines connues chez les animaux comme étant des sélénoenzymes, telles qu'une TR ou des PHGpx et de manière plus surprenante une MsrA. En effet, certaines MsrB sont connues pour posséder un résidu sélénocystéine mais pas les MsrA. Cette enzyme est longue de 159 acides aminés, possède une sélénocystéine en position conservée à la place de la cystéine catalytique (C51 pour l'enzyme d'*E. coli*). Par contre, elle ne possède aucune des deux autres cystéines essentielles situées dans la partie C-terminale (C196 et C202 pour l'enzyme d'*E. coli*).

#### 4. Mon travail de thèse

Le travail expérimental présenté dans cette thèse sous la forme d'articles de recherche a pour objet la caractérisation, tant biochimique que structurale, des protéines impliquées dans le maintien de l'homéostasie rédox intracellulaire chez les végétaux que sont les Trx et les Grx en utilisant comme modèle d'étude le peuplier (*Populus x interamericana* Brockh.) clone 'Beaupré'. Ces travaux ont fait l'objet de 6 articles. Les 2 articles portant sur les Trx ont permis de caractériser deux isoformes de Trx, l'une cytosolique (**Identification and characterization of a third thioredoxin *h* in poplar**) et l'autre mitochondriale (**Isolation and characterization of an extended thioredoxin *h* from poplar**). Les 4 autres articles décrivent la caractérisation des propriétés rédox d'une isoforme de Grx de peuplier et les résultats préliminaires de la structure cristallographique de cette Grx en complexe avec le GSH et s'intitulent (i) **Enhancement of poplar glutaredoxin expression by optimization of the cDNA sequence**, (ii) **Exploring the active site of plant glutaredoxin by site-directed mutagenesis**, (iii) **Characterization of the redox properties of poplar glutaredoxin** et (iv) **Crystallization and preliminary X ray data of poplar glutaredoxin**.

De plus, une attention particulière a été portée sur deux types d'enzymes cibles des Trx ou des Grx du fait de leur implication potentielle dans la réponse aux stress chez les plantes, les Prx et les MsrA.

Deux isoformes de Prx, une Prx de type IIC et une Prx Q, ont ainsi été caractérisées en terme d'expression et de localisation dans les différents organes de la plante. Leurs propriétés catalytiques, leurs spécificités de substrats et leurs capacités à accepter des électrons de divers donneurs ont également été examinées notamment par des expériences de mutagenèse dirigée et par détermination de leur structure. Le travail sur la Prx de type II a fait l'objet de 3 articles intitulés : (i) **Isolation and characterization of a new peroxiredoxin from poplar sieve tubes that uses either glutaredoxin or thioredoxin as a proton donor**, (ii) **Glutaredoxin-dependent peroxiredoxin from poplar: protein-protein interaction and catalytic mechanism**, (iii) **Crystallisation and preliminary X-ray data of a bifunctional peroxiredoxin from poplar** et d'un quatrième en cours de révision (iv) **Active site mutagenesis and phospholipid hydroperoxide reductase activity of poplar type II peroxiredoxin**. Le travail sur la Prx Q est présenté dans un article en

préparation : **Molecular characterization of chloroplastic poplar peroxiredoxin Q and its involvement in the pathogenic response.**

Deux isoformes de MsrA, plastidiale et cytosolique, ont également été étudiées d'un point de vue fonctionnel et structural. Cette étude est présentée sous la forme d'un article en préparation intitulé : **Functional and structural aspects of poplar cytosolic and plastidial type A methionine sulfoxide reductases.**

## *Résultats*

---

## *Chapitre I : les systèmes réducteurs*



Les deux systèmes réducteurs enzymatiques principaux dans une cellule sont les systèmes Trx et Grx. Chez les plantes, il semble que ces systèmes soient représentés par un grand nombre d'isoformes dans les différents compartiments cellulaires.

Le système Trx chloroplastique est le mieux connu, mais de nouvelles séquences de Trx chloroplastiques, dont on ne connaît pas la fonction précise, émergent (Meyer et al., 2002). Par ailleurs, les enzymes composant le système mitochondrial viennent seulement d'être caractérisées chez *A. thaliana* (Laloi et al., 2002). Au niveau cytosolique, au moins 8 isoformes de Trx h coexistent chez *A. thaliana* (Meyer et al., 2002).

Au début de mon travail de thèse, très peu de données étaient disponibles sur les Grx végétales alors que leurs homologues bactériens et animaux étaient beaucoup mieux caractérisés. Pourtant, le séquençage du génome d'*A. thaliana* démontre l'existence potentielle de multiples isoformes dans le cytosol, les chloroplastes et les mitochondries (voir tableau I de l'introduction).

Avant mon arrivée dans le laboratoire, une isoforme cytosolique de Trx de peuplier appelée popTrx h1 a été caractérisée (Behm & Jacquot, 2000). Cette protéine est en réalité l'homologue d'un point de vue séquence primaire du site actif (WCPPC) des Trx h3, h4 ou h5 d'*A. thaliana*. Deux autres isoformes présumées cytosoliques ont ensuite été isolées et caractérisées et font l'objet des articles 5 et 6.

Par ailleurs, une isoforme de Grx bicystéinique, homologue à la séquence CxxC4 d'*A. thaliana* (voir Tableau I et Figure 9 de l'introduction) a également été au centre de mon travail de recherche. La caractérisation structurale et fonctionnelle de cette enzyme est reportée dans les articles 7 à 10.

Article numéro 5 :

**Gelhaye E, Rouhier N, Laurent P, Sautière PE, Martin F, Jacquot JP. (2002)**

*Isolation and characterization of an extended thioredoxin h from poplar.*

***Physiol. Plant.* 114(2):165-171.**

Cet article présente l'isolement et la caractérisation d'une deuxième Trx de peuplier (popTrx h2) de 143 acides aminés. Par rapport à la première protéine isolée, cette deuxième variante présente une extension du côté N-terminal et la protéine recombinante est naturellement clivée dans *E. coli*. Son site actif (WCGPC) diffère de celui de popTrx h1 (WCPPC). Les caractéristiques physico-chimiques et catalytiques de la protéine recombinante ont été comparées à celles de popTrx h1. De récentes expériences de fusion avec la GFP démontrent que popTrx h2 est vraisemblablement une protéine mitochondriale alors qu'on présumait qu'elle était localisée dans le cytosol. Cette protéine, différente des deux isoformes de Trx mitochondriales d'*A. thaliana* appelées AtTrx o1 et o2, ne possède que 25% d'identité avec ces Trx o. Pour ces raisons, cette isoforme devrait être appelée dorénavant popTrx o3 plutôt que popTrx h2 si les isoformes équivalentes à AtTrx o1 et o2 existent chez le peuplier.

## Isolation and characterization of an extended thioredoxin *h* from poplar

Eric Gelhaye<sup>a</sup>, Nicolas Rouhier<sup>a</sup>, Pascal Laurent<sup>a</sup>, Pierre-Eric Sautière<sup>c</sup>, Francis Martin<sup>b</sup> and Jean-Pierre Jacquot<sup>a,\*</sup>

<sup>a</sup>UMR IaM 1136 INRA-Université H. Poincaré-Nancy I. Faculté des Sciences F-54506 Vandoeuvre, France

<sup>b</sup>UMR IaM 1136 INRA-Université H. Poincaré-Nancy I. Centre INRA de Nancy., F-54280 Champenoux, France

<sup>c</sup>Laboratoire d'Endocrinologie des Annélides UPRESA 8017. Université des Sciences et Technologies de Lille, F-59655 Villeneuve d'Ascq Cedex, France

\*Corresponding author, e-mail: j2p@scbiol.uhp-nancy.fr

Received 2 April; revised 13 August 2001

A cDNA coding for a thioredoxin *h* has been isolated from a xylem/phloem poplar cDNA library by RACE-PCR. The nucleotide sequence called popTrx-*h2* is homologous to other thioredoxins *h* isolated from plants but differs from the other thioredoxins *h* by presenting a 30 amino acid long N-terminal extension. A variant of this cDNA lacking the N-terminal extension was also generated by PCR. Both cDNAs have been introduced into an expression plasmid (pET-3d) and the recombinant proteins have been expressed to a high level and purified from *Escherichia coli* cells. Protein sequencing showed that a part of the N-terminal extension was cleaved in the *E. coli* cells, with the first 19 amino acids

missing, suggesting the presence of a putative cleavage site in the N-terminal extension of popTrx-*h2*. Both recombinant proteins display unusual catalytic properties compared to other thioredoxins *h* characterized so far, i.e. a weak reduction by *Arabidopsis thaliana* NADPH-dependent thioredoxin reductase, and a weak activation of the chloroplastic NADP-malate dehydrogenase, a non-physiological target enzyme. Northern blot experiments indicate that the transcripts of popTrx-*h2* are present in leaves and roots, albeit at a lower level compared to the earlier characterized popTrx-*h1*.

### Introduction

In plants, thioredoxins are a multigenic family of redox proteins containing a disulphide bridge involved in several metabolic functions inside and outside the cells (For a review, see Schürmann and Jacquot 2000). Sequence analyses have revealed three different thioredoxin groups in the plant cells. The first group contains thioredoxins similar to the prokaryotic thioredoxins, the prototype of which is the *Escherichia coli* thioredoxin, a protein very well characterized both kinetically and structurally (Holmgren 1968, Katti et al. 1990, Jeng et al. 1994). These thioredoxins are nucleus-encoded (Stein et al. 1995) but localized in the chloroplasts and reduced by a ferredoxin-thioredoxin reductase (FTR). These thioredoxins are efficient catalysts in vitro of the reduction/activation of the chloroplast NADP-malate dehydrogenase (NADP-MDH) and have been accordingly called thioredoxins *m*. The second group of nucleus-encoded chloroplast thioredoxins, also reduced by FTR and

called thioredoxins *f*, are very specific activators of the fructose-1,6-bisphosphatase of the Calvin cycle. This type of thioredoxin has also been described in terms of reactivity and structure (Hirasawa et al. 1999, Capitani et al. 2000). Finally, plants contain a third type of thioredoxins, the thioredoxins *h* (for heterotrophic), that are presumably located in the cytosol. In this cytosolic system, the reducing power of NADPH is transferred via a flavoprotein-the NADPH-thioredoxin reductase (NTR) (Florencio et al. 1988). A number of thioredoxin *h* sequences have since been isolated from both non-photosynthetic and photosynthetic tissues, most notably from *Arabidopsis thaliana* (Rivera-Madrid et al. 1995). Primary structure analyses indicate that all *h* type proteins are closely related on an evolutionary standpoint (Jacquot et al. 1997). The cytosolic thioredoxin displays at least one specific characteristic that allows its identification: the presence of a conserved Trp residue (W13

*Abbreviations* – DTT, Dithiotreitol; DTNB, 5,5' dithiobis nitrobenzoic acid; EST, expressed sequence tag; NADP-MDH, NADP-dependent malate dehydrogenase; NTR, NADPH-thioredoxin reductase; Trx, thioredoxin.

in *Chlamydomonas reinhardtii*) that induces peculiar UV spectral characteristics (Stein et al. 1995, Lemaire et al. 2000). Among the proposed functions for cytosolic thioredoxins is the modulation of the activity of transcription factors (Huang and Domann 1998), and receptors as the S-locus receptor kinase in plants by redox regulation in vitro (Bower et al. 1996). More recently, thioredoxin-dependent antioxidant systems based on the existence of thioredoxin-dependent peroxidases have been found in yeast and *Arabidopsis thaliana* (Jeong et al. 1999, Lee et al. 1999, Verdoucq et al. 1999). Thus, cytosolic thioredoxins are likely to be involved in signaling pathways, developmental processes, as well as anti-oxidant systems.

In the present study, we have extended the characterization of the redox equipment of poplar (Behm and Jacquot 2000, Rouhier et al. in press), since the nature of the dithiol/disulphide components in woody plants is still poorly understood. We present in this paper the characterization of an extended thioredoxin *h* of poplar, which differs from the previously characterized plant cytosolic thioredoxins.

## Materials and methods

### *Escherichia coli* strains and mRNA and cDNA libraries

*E. coli* strain DH5 $\alpha$  F' and BL21(DE3) were used throughout this study. The plasmid for expression was pET-3d (<sup>93</sup>Studier 1991). The phage cDNA library of *Populus trichocarpa* cv. Trichobel was kindly provided by Drs Wout Boerjan and Hugo Meyermans (University of Gent, Belgium) and Dr S. Larsson (University of Umeå). Bacteria were grown at 37°C in Luria-Bertani medium (LB), supplemented with ampicillin (50  $\mu$ g ml<sup>-1</sup>) when the bacteria carried plasmids conferring resistance to this antibiotic. Poplar leaves mRNA preparation was performed using RNA Easy Plant MiniKit (Qiagen, S.A. Courtaboeuf, France).

### Primer design and PCR reaction

A primer was constructed based on the expressed sequence tag (EST AI164262) corresponding to a putative 5'-end of *P. tremula* x *P. tremuloïdes* thioredoxin *h* cDNA identified with the Blast program (<http://www.ncbi.nlm.nih.gov>). Based on the N-terminal sequence MEFAPVC, an upstream oligonucleotide (*For1*) was synthesized homologous to the coding strand, including the addition of four extra-nucleotides and of a *NcoI* restriction site underlined in the sequence: CCCCCATGGAGTTTGCTTGGCCAGTTCTTC.

The full-length cDNA was obtained using the SMART<sup>TM</sup> 3'RACE cDNA amplification kit (Clontech Laboratories, Palo Alto, USA) from an mRNA preparation together with oligonucleotide *For1* and subsequent cloning into a pT-Adv vector using the Advantage PCR cloning Kit (Clontech). The ligation sample was directly used to transform *E. coli* strain DH5 $\alpha$  by electropor-

ation. The recombinant plasmids were isolated and purified as described in Sambrook et al. (1989). The nucleotide sequence of the insert was determined by dideoxynucleotide sequencing. The resulting construction was named pET-popTrxh-2-A.

Two additional primers were constructed based on the sequence of the pET-popTrxh-2-A construction. An upstream oligonucleotide *For2* was synthesized homologous to the coding strand, including an addition of four extra-nucleotides and of a *NcoI* restriction site underlined with the sequence that matches an N-terminus sequence MAGVVDVH: CCCCCATGGCTGGRGTTGTGGATGTCCAT. A downstream oligonucleotide called *Rev* was derived from the 3'-end of the non-coding strand, featuring at the 5'-end four additional T and a *BamHI* restriction site underlined with the sequence: TAACTCTTCGTACCCTACTATATTCCTAGGTTTT corresponding to the C-terminus sequence IEKHGMI. PCR reactions were performed using *For2/Rev* and *For1/Rev* primer couples and the cDNA library as template DNA.

### Cloning PCR products and DNA sequencing

The PCR products of the right size were purified on agarose gel, digested with both *BamHI* and *NcoI* restriction endonucleases and cloned into the pET3d plasmid digested with the same restriction endonucleases. The nucleotide sequences of the inserts were determined by dideoxynucleotide sequencing. The resulting constructions were named pET-popTrxh-2L for the construction resulting from the *For1-Rev* PCR and pET-popTrxh-2S for the construction resulting from the *For2-Rev* PCR.

### Production and purification of recombinant thioredoxins *h*

The purified pET-popTrxh-2S and pET-popTrxh-2L plasmids were used to transform *E. coli* BL21(DE3) strain. One colony was used to inoculate 3 ml LB medium, supplemented with ampicillin (50  $\mu$ g ml<sup>-1</sup>). The culture was successively amplified to a final volume of 3 l over a period of 24 h and induced with 100  $\mu$ M IPTG for 6 h. The cells were then collected by centrifugation and suspended in 50 mM phosphate buffer (pH 7.0). The cell suspension was disrupted by sonication. The resulting sample was fractionated with ammonium sulphate. The fraction precipitating between 40 and 80% of the saturation was suspended in a minimal volume of 50 mM phosphate buffer (pH 7.0). The purification was then performed as described previously (Behm and Jacquot 2000) using Sephadex G50 gel filtration and DEAE-Sepharose columns.

### Enzyme assays

The reduction of insulin was measured at 650 nm using the turbidimetric reaction described previously (Holmgren 1979). The activation of sorghum recombinant NADP-MDH was followed by measuring the activ-

ity of the enzyme at 340 nm, using a 2-step assay (Jacquot et al. 1995). The reduction of thioredoxin by NADPH and the recombinant *A. thaliana* NADPH-thioredoxin reductase was followed at 412 nm, using DTNB as a substrate (Jacquot et al. 1995).

#### RNA extraction and Northern Blot experiment

Total RNA was extracted from 100 mg of leaves, stems and roots from a 2-month-old poplar (*Populus trichocarpa* × *deltoides*) grown in hydroponic medium, with the RNeasy Plant Mini Kit from Qiagen with the addition of polyethyleneglycol 8000 to the extraction buffer at a concentration of 20 mg ml<sup>-1</sup>. 10 µg of total RNA were separated and blotted by capillarity onto a Nylon + membrane from Amersham Pharmacia Biotech (Uppsala, Sweden). The probe consisting of approximately 100 ng of a PCR fragment (popTrxh-2S or popTrxh-1) was labelled with <sup>32</sup>P dATP following the instructions provided in the kit Prime a Gene Labelling System (Promega, Charbonnières, France). The probe was then purified with the QIAquick Nucleotides Removal Kit from Qiagen, and was estimated to contain 30 millions cpm. Hybridization was performed at 42°C in the presence of SSPE 20X, SDS 20% and washing at 65°C with a solution of SSPE 2X and SDS 0.1%.

### Results and discussion

#### Molecular cloning of the cDNA, popTrxh2L, and comparison of its amino acid sequence with other thioredoxins

Using the Blast program, we have identified several sequences for thioredoxin *h* in the xylem/phloem poplar EST library (<http://http://www.biochem.th.se/PopulusDB/>). One of these sequences (GenBank access A1164262) corresponds to the putative 5'-end of a thioredoxin *h* cDNA (called in this study popTrxh-2). In order to characterize the full-length gene, total mRNAs have been purified, the corresponding poplar cDNA synthesized and 3' RACE cDNA amplification performed using a homologous synthetic oligonucleotide deduced from the EST sequence. A single PCR fragment of about 600 bp was generated and cloned into the pT-Adv vector. The insert was sequenced and the obtained sequence was used to synthesize a reverse oligonucleotide called *Rev*. The full-length cDNA has been isolated by PCR using both homologous synthetic oligonucleotides *For 1* and *Rev* described in Materials and methods. Those oligonucleotides contained restriction sites in order to clone directly the sequence into the expression plasmid pET3d and produce the recombinant protein, yielding the construct pET-Trxh2L. Furthermore, the stop codon TGA observed in the EST sequence was changed in TAA which is used at much higher frequencies in *E. coli*. A single PCR fragment of the expected size was generated and digested with the restriction enzymes *NcoI* and *BamHI* and cloned into the expression vector pET3d

digested with the same enzymes. The sequence of the reconstituted cDNA is shown Fig. 1. Overall the sequence contains 741 bp and the 3' UTR represents 240 bp. The putative encoded protein is 143 amino acids long (including the initiator methionine) with a molecular mass of 16358 Da. The deduced amino acid sequence was compared to sequences deposited in the public databases using the Blastp program provided by the NCBI E-mail: server (Altschul et al. 1990). It displays extensive sequence similarities (ranging from about 50–68%) to other plant thioredoxins *h* (Fig. 2), containing the conserved N-terminus tryptophane residue (W45), which is a signature of the thioredoxin *h* sequences (W13 in *Chlamydomonas reinhardtii*) (Stein et al. 1995, Lemaire et al. 2000).

When compared with other thioredoxins *h* of a variety of organisms, the deduced poplar thioredoxin *h* amino acid sequence features a 30 amino acid extension at its N-terminus. Two putative thioredoxins *h* sequenced from genomic DNA of *Arabidopsis thaliana* (Genbank accession number: AAF07385 and AAD39316) and the *A. thaliana* Trxh-gif2 (Rivera-Madrid et al. 1995) share this feature, although no significant homology is observed between those N-terminus extensions. Two wheat thioredoxins *h* have also been shown to possess 15–18 amino acids-long N-terminus extensions corresponding to a putative transmembrane domain (Gautier et al. 1998). The popTrxh-2 N-terminus sequence clearly differs from the wheat thioredoxins *h*. The use of the PSORT program or a similar program does not allow the identification of a signal sequence in the N-terminus extension, which apparently does not possess the characteristics of transit peptides associated with import or excretion of proteins in plants. Thus the significance of the N-terminus extension so far remains unclear.

#### Production of recombinant thioredoxin h-2L

After expression of the recombinant protein in BL21 cells as described in Materials and methods, the poplar thioredoxin *h*-2L was purified to homogeneity by a combination of heat treatment, ammonium sulphate precipitation (40–80%), G50 gel filtration and anion exchange on a DEAE matrix. The final yield of the preparation was approximately 4 mg protein l<sup>-1</sup> culture. The SDS-PAGE revealed that the recombinant protein was homogeneous (data not shown). N-terminus protein sequencing showed that a part of the N-terminus extension was cleaved in the *E. coli* cells (cf Fig. 1), the first 19 amino acids were missing, indicating the presence of a putative cleavage site in the N-terminus extension of popTrxh-2. The addition of protease inhibitors during the purification steps did not change this property.

#### Spectroscopic and catalytic properties

The UV spectrum of poplar thioredoxin *h*-2L presented in Fig. 3 displays a peculiar characteristic that is found in all plant thioredoxins *h* characterized so far, namely

a shoulder at approximately 290 nm. This absorption spectrum is characteristic of Trp residues and has been attributed to poplar *h*-2L residue W45, the equivalent of W13 in *Chlamydomonas reinhardtii* (Lemaire et al. 2000).

All the above properties suggest that the isolated recombinant protein is indeed a thioredoxin *h*. Furthermore, the catalytic properties of the poplar thioredoxin *h*-2L were investigated, particularly its ability to reduce disulphide bridges on selected proteins.

Figure 4A shows an insulin reduction reaction in the presence of 0.5 mM dithiothreitol and 2.8  $\mu$ M recombinant thioredoxin *h*. The increase in absorbance at 650 nm indicates the precipitation of the insulin chains due to the reduction of the disulphide bonds. The efficiency of the recombinant poplar thioredoxin *h*-2L in this reaction

was found to be similar to other plant thioredoxins studied so far (Wetterauer et al. 1992).

Figure 4B shows the reduction of DTNB in the presence of NTR dependent reduction system. In this test, the recombinant poplar thioredoxin *h*-2L is not very efficient ( $K_m$  of approximately 12  $\mu$ M), with a  $K_m$  of about 10 fold higher compared to the value measured with poplar thioredoxin *h*-1 ( $K_m$  of approximately 1.5  $\mu$ M) (Behm and Jacquot 2000). As a consequence poplar thioredoxin *h*-2L is also reduced by the NADPH-dependent thioredoxin system from *A. thaliana*, but with a weaker efficiency compared to other thioredoxins *h*.

Figure 4C shows the effect of DTT reduced thioredoxin *h*-2L from poplar on the NADP-MDH activity. This thioredoxin *h* activated very weakly the chloroplastic protein in presence of DTT, preventing the determi-

```

1
CGA CAG TGC TTT GTT TGG AGT AAA GCA TTC TAG CTA CGT GAG TCA GCT ATG GAG TTT
                                     M E F

58/4
GCT TGG CCA GTT CTT CAG CGA GGA AGA ACA GTG CAA ACA AGC TTC TTT AAT TTT GAT
A W P V L Q R G R T V Q T S F F N F D
                               Recomb PopTrxh-2L ↑

116/23
CAC TCC AAT GGA TTT CCA TGC ACA AAG CCA GCT GCT GGG GTT GTG GAT GTC CAT TCT
H S N G F P C T K P A A G V V D V H S
                               Poptrhx-2S → M

174/42
GTA GGC GCA TGG AGA TCC TAT TTC GAG GCC AAC AAG CAA AAC AAC AAA TTG CTG GTG
V G A R S Y F E A N K Q N N K L L V

232/61
ATT GAA TTC ACG GCG ACA TGG TGT GGA CCT TGC CGA TAC ATG GAG CAG ACC ATG AAG
I E F T A T C G P C R Y M E Q T M K

290/80
GAC TTT GCT GCC AAG TAC ACA GAC GTT GTG TTC ATC AGG ATT GAC GTT GAT GAA TTG
D F A A K Y T D V V F I R I D V D E L

348/99
CAG CAT GTG GCT CAG CAA TTC AAT GTG ACT ACC ATG CCA GCA TTT TCA CTC TTG AAG
Q H V A Q Q F N V T T M P A F S L L K

406/118
AAA GGG AAG ATA GTT GAC GAG GTA GCA GGG GTC AAG AAG AGT GAG CTT CAG AAC AAG
K G K I V D E V A G V K K S E L Q N K

464/137
ATT GAG AAG CAT GGG ATG ATA TGA TTG CCA CGA TAC TTA ACT ATT AAT GCC ATG CCC
I E K H G M I *

522
ATG GCG AAT CCC TGC TGG AAT GTA TAT TCC AGC AGA AGA GAA GAA TAA AAC AAG GCC

580
TCA AAA GCA ATT TGC TGA GGC AAA AAT AAG GCC ATC CTT TTT TCT TTT CTT CTT CTT

638
GAT TGC TAT TAT TTA ATA TAC GTA TTG TAA TGC CAA GTT AAT TTT TAT TTA AGA AAA

696
CTC ATT TTC TCA AAA AAA AAA AAA AAA AAA AAA AAA
    
```

Fig. 1. Nucleotide and amino acid deduced sequences of poplar thioredoxin *h*-2.

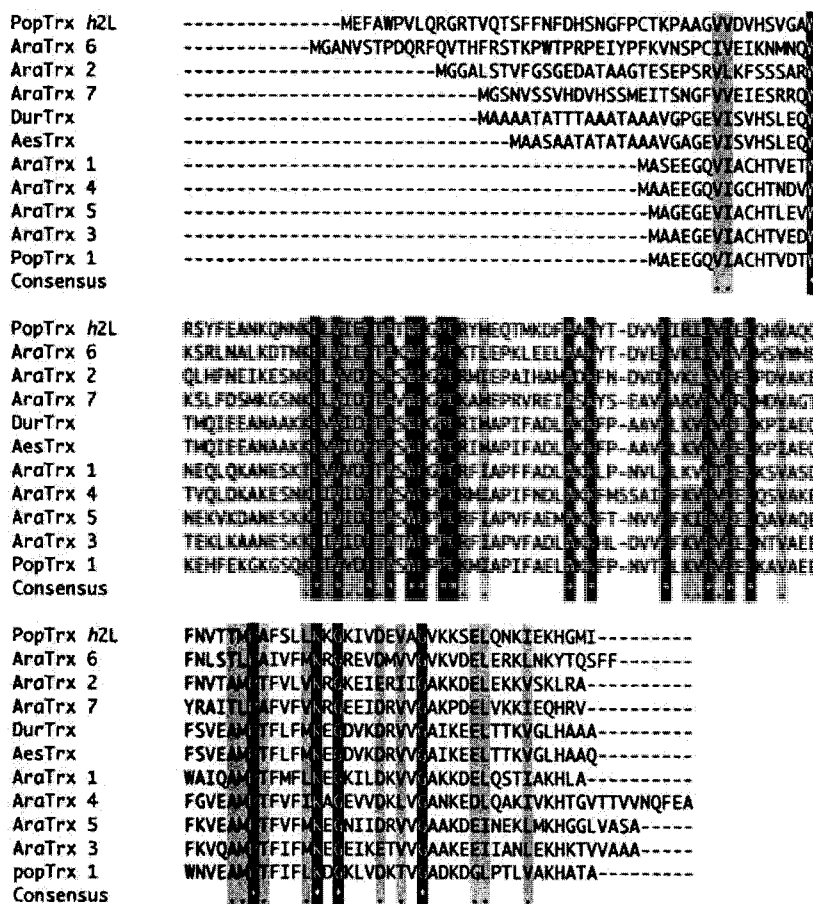

Fig. 2. Amino acid comparison of thioredoxins *h*. The sequences are from *Populus trichocarpa* cv. *Trichobel*, popTrx 1 (A1161830); *Arabidopsis thaliana*, AraTrx 1 (Z14084), AraTrx 2 (Z35475), AraTrx 3 (Z35474), AraTrx 4 (Z35473), AraTrx 5 (Z35476), AraTrx 6 (AAF07385), AraTrx 7 (AAD39316); *Triticum aestivum*, AesTrx (X69915); *Triticum durum*, DurTrx (AJ001903). Asterisks indicate conserved amino acids in all sequences, dots indicate amino acids with similar biochemical properties, and dashes represent gaps introduced to optimise the alignment.

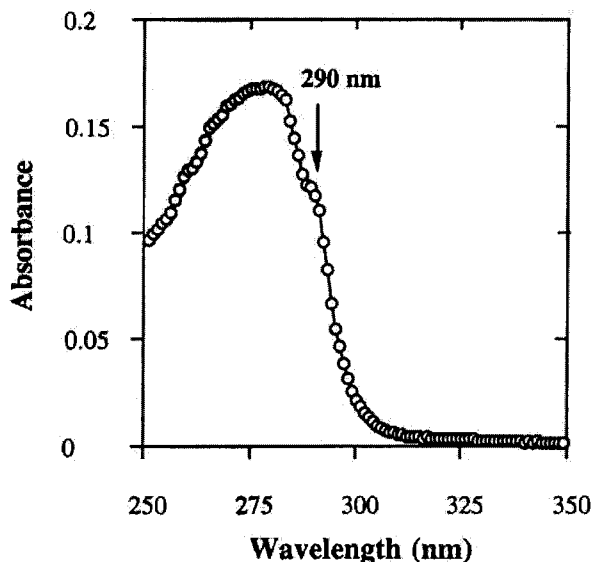

Fig. 3. UV spectrum of poplar thioredoxin *h-2L*. The spectrum was determined by measuring the absorbance point by point in TE buffer at room temperature. The recombinant popTrx *h-2L* was used at 2.8  $\mu$ M. A similar spectrum was obtained for thioredoxin *h-2S* (data not shown)

nation of a significant S0.5. In comparison, the previously characterized *Chlamydomonas reinhardtii* and *A. thaliana* thioredoxins *h* (Rivera-Madrid et al. 1995, Stein et al., 1995) as well as poplar thioredoxin *h-1* (Behm and Jacquot 2000) are efficient activators of this enzyme in this artificial system.

#### Preparation and characterization of the recombinant popTrx-h2S

Since poplar thioredoxin *h-2* presents an N-terminus extension and unusual catalytic properties, a mutant poplar thioredoxin *h-2S* was prepared, as described in Materials and methods, leading to a shorter recombinant protein (113 AA) without the N-terminus extension, similar in size to the majority of the thioredoxins *h* characterized so far (Fig. 2). The recombinant protein poplar thioredoxin *h-2S* was purified to homogeneity from *E. coli* cells using the same procedure as for thioredoxin *h-2L*. The UV spectrum of recombinant thioredoxin *h-2S* displays the same bump at 290 nm that observed using thioredoxin *h-2L* (cf. Figure 3). The same spectrum was obtained when both recombinant proteins were analysed using circular dichroism (data not shown) and the thermostability of both proteins was found to be similar

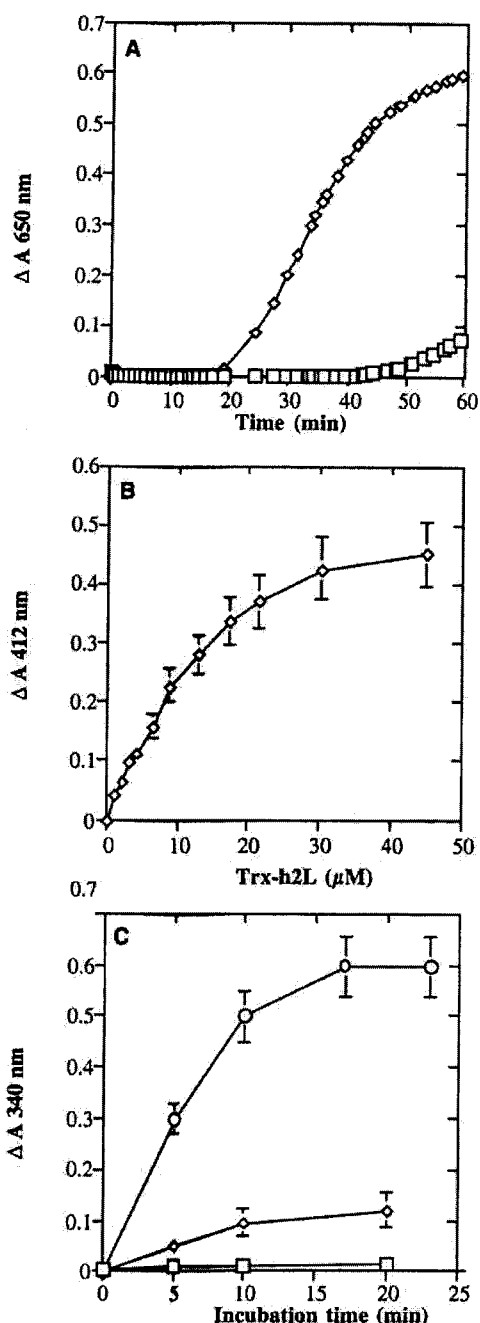

Fig. 4. Catalytic properties of poplar thioredoxin *h-2L*. (a) Reduction of disulphide bridges of human insulin.  $\diamond$  2.8  $\mu$ M popTrx *h-2L*, 0.5 mM DTT and insulin;  $\square$  0.5 mM DTT and insulin. (b) DTNB reduction by the NTR system. Various amounts of oxidised thioredoxins were incubated in the presence of 77.5 nM NTR, 150  $\mu$ M NADPH, 100  $\mu$ M DTNB in buffer 30 mM Tris-HCl (pH 8.0). DTNB reduction was measured at 412 nm as absorbance change per min. Error bars indicate the variations in the assays. (c) NADP-MDH activation. 27  $\mu$ l was used to measure the NADP-MDH activity in 1 ml reaction (Stein et al. 1995). Error bars indicate the variations in the assays. Trx-*h2S* exhibited similar catalytic properties (data not shown).

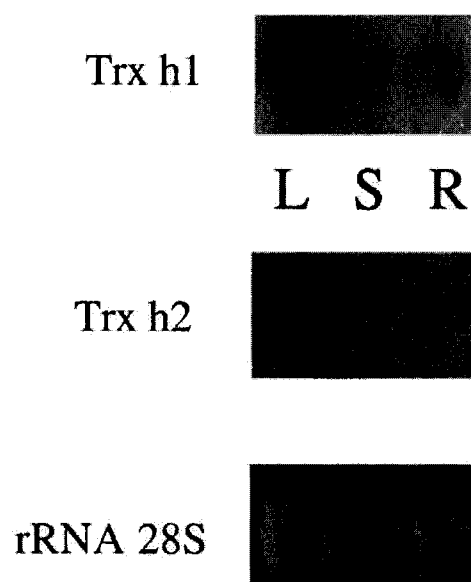

Fig. 5. Northern blot experiments. Trx *h-1*: Hybridization with thioredoxin *h-1* probe; Trx *h-2*: Hybridization with the thioredoxin *h-2* probe; rRNA 28S: Ethidium bromide staining of the 28S rRNA band. L: leaves, S: stems; R: roots.

(data not shown). In addition, the catalytic properties of thioredoxin *h-2S* were investigated. Thioredoxin *h-2S* is also reduced by the NADPH-dependent thioredoxin system from *A. thaliana* but with a weak efficiency ( $K_m$  about 12  $\mu$ M) as observed with popTrx-2L. Furthermore, both recombinant proteins exhibited the same weak activation of the chloroplastic NADP-MDH. All the above data suggest that the N-terminus extension of thioredoxin *h-2* is probably not the reason for the low activity of the protein in the conditions used in this study.

#### Presence of transcripts in poplar

Poplar thioredoxins *h1* and *h2* are only 53% identical at the nucleotide level, and it is thus quite easy to discriminate between the two sequences by hybridizing at relatively high stringency. A Northern blot experiment shown in Fig. 5 indicates that the transcripts for Trx *h-2* can be found in leaves and roots but not in stems. The same samples were probed with a fragment coding for thioredoxin *h1*. Although the transcripts for thioredoxin *h1* are present in minor amounts in stems, they can be found in all compartments of the plant, but they are clearly more abundant in leaves. Overall, the level of transcription for thioredoxin *h1* seems to be higher than the one for thioredoxin *h-2*. The size of the transcripts for Trx-*h-1* and Trx-*h-2* is quite similar at around 800 bp.

#### Concluding remarks

The characterization of a new thioredoxin *h* sequence in poplar is a finding of interest for several reasons. First



it shows that trees such as poplar contain several genes coding for this protein, similar to the herbaceous plant *Arabidopsis thaliana* (Rivera-Madrid et al. 1995). The two poplar sequences that have been characterized exhibit rather low homologies (53% identity at the nucleotide level, but only 38% identity and 60% homology at the protein level). As a consequence, thioredoxin *h-2* is not, or extremely poorly, recognised by polyclonal antibodies raised against thioredoxin *h-1* (data not shown), a property that will allow us to discriminate the two polypeptides by immunochemistry. Moreover, the two proteins have distinct active sites (WCPPC for thioredoxin *h-1* and WCGPC for thioredoxin *h-2*). In addition, poplar thioredoxin *h-2L* shows an extended N-terminus. Furthermore, when expressed in *E. coli* cells, the full-length recombinant protein is processed. It has been shown previously that the *E. coli* machinery is able to mature polypeptides in a manner analogous to higher plants (Jacquot et al. 1991). The recombinant protein displays unusual catalytic properties compared to other plant thioredoxins *h*. A similar specificity was observed with the truncated mutant protein. These data suggest that the N-terminus extension of thioredoxin *h-2L* correspond, at least in part, to a signal peptide that could be recognised by the *E. coli* system. However, since a motif similar to other transit peptides was not detected in the Trx*h-2L*, the significance of the extension sequence remains unclear.

We have recently isolated a sequence coding for full-length Trx*h-2* in a poplar EST library obtained from root material (unpublished) which suggests a wide distribution of this protein in poplar. The results of the Northern blot experiment also indicate that this gene is transcribed both in leaves and roots. This observation coupled to its unusual catalytic properties suggests that Trx*h-2* could be involved *in vivo* in important and specific reactions. To understand the function of this newly described thioredoxin, studies of subcellular and tissue localization of this protein, as well as research on its mode of reduction will be carried out.

## References

- Altschul SF, Gish W, Miller W, Myers EW, Lipman DJ (1990) Basic local alignment search tool. *J Mol Biol* 215: 403–410
- Behm M, Jacquot JP (2000) Isolation and characterization of thioredoxin *h* from poplar xylem. *Plant Physiol Biochem* 38: 363–369
- Bower MS, Matias DD, Fernandes-Carvalho E, Mazzurco M, Gu TS, Rothstein SJ, Goring DR (1996) Two members of the thioredoxin-*h* family interact with the kinase domain of a *Brassica* S locus receptor kinase. *Plant Cell* 8: 1641–1650
- Capitani G, Markovic-Housley Z, DelVal G, Morris M, Jansonius JN, Schürmann P (2000) Crystal structures of two functionally different thioredoxins in spinach chloroplasts. *J Mol Biol* 302: 135–154
- Florencio FJ, Yee BC, Johnson TC, Buchanan BB (1988) An NADP-*h*thioredoxin system in leaves. Purification and characterization of NADP-thioredoxin reductase and thioredoxin *h* from spinach. *Arch Biochem Biophys* 266: 496–507
- Gautier MF, Lullien-Pellerin V, Lamotte-Guery F, Guirao A, Joudrier P (1998) Characterization of wheat thioredoxin *h* cDNA and production of an active *Triticum aestivum* protein in *Escherichia coli*. *Eur J Biochem* 252: 314–324
- Hirasawa M, Schürmann P, Jacquot JP, Manieri W, Jacquot P, Keryer E, Hartman FC, Knaff DB (1999) Oxidation-reduction properties of chloroplast thioredoxins, ferredoxin, thioredoxin reductase, and thioredoxin f-regulated enzymes. *Biochemistry* 38: 5200–5205
- Holmgren A (1968) Thioredoxin. The amino acid sequence of the protein from *Escherichia coli*. *Eur J Biochem* 6: 475–484
- Holmgren A (1979) Reduction of disulfides by thioredoxin. Exceptional reactivity of insulin and suggested functions of thioredoxin in mechanism of hormone action. *J Biol Chem* 254: 9627–9632
- Huang Y, Domann FE (1998) Redox modulation of AP-2 DNA binding activity in vitro. *Biochem Biophys Res Commun* 249: 307–312
- Jacquot JP, Keryer E, Issakidis E, Decottignies P, Miginiac-Maslow M, Schmitter JM, Crétin C (1991) Properties of recombinant NADP-malate dehydrogenases from *Sorghum vulgare* leaves expressed in *Escherichia coli*. *Eur J Biochem* 199: 47–51
- Jacquot JP, Issakidis E, Decottignies P, Lemaire M, Miginiac-Maslow M (1995) Analysis and manipulation of target enzymes for thioredoxin control. *Meth Enzymol* 252: 240–252
- Jacquot JP, Lancelin JM, Meyer Y (1997) Thioredoxins: Structure and function in plant cells. *New Phytol* 136: 543–570
- Jeng MF, Campbell AP, Begley T, Holmgren A, Case DA, Wright PE, Dyson HJ (1994) High-resolution solution of oxidized and reduced *Escherichia coli* thioredoxin. *Structure* 2: 853–868
- Jeong JS, Kwon SJ, Kang SW, Rhee SG, Kim K (1999) Purification and characterization of a second type thioredoxin peroxidase (type II TPx) from *Saccharomyces cerevisiae*. *Biochemistry* 38: 776–783
- Katti SK, Lemaster DM, Eklund H (1990) Crystal structure of thioredoxin from *Escherichia coli* at 1.68 Å Resolution. *J Mol Biol* 212: 167–184
- Lee TH, Yu SL, Kim SU, Kim YM, Choi I, Kang SW, Rhee SG, Yu DY (1999) Characterization of the murine gene encoding 1-Cys peroxiredoxin and identification of highly homologous genes. *Gene* 234: 337–344
- Lemaire SD, Richardson JM, Goyer A, Keryer E, Lancelin JM, Makhatazde GI, Jacquot JP (2000) Primary structure determinants of the pH- and temperature-dependent aggregation of thioredoxin *h*. *Biochem Biophys Acta* 1476: 311–323
- Rivera-Madrid R, Mestres D, Marinho P, Jacquot JP, Decottignies P, Miginiac-Maslow M, Meyer Y (1995) Evidence for five divergent thioredoxin *h* sequences in *Arabidopsis thaliana*. *Proc Natl Acad Sci USA* 92: 5260–5264
- Rouhier N, Gelhaye E, Sautiere PE, Brun A, Laurent P, Tagu D, Gerard J, de Fay E, Meyer Y, Jacquot JP (2001) Isolation and characterization of a new peroxiredoxin from poplar sieve tubes that uses either glutaredoxin or thioredoxin as a proton donor. *Plant Physiol* 127: 299–309
- Sambrook J, Fritsch EF, Maniatis T (1989) *Molecular cloning: A laboratory manual*. Cold Spring Harbor, New York, NY
- Schürmann P, Jacquot JP (2000) Plant thioredoxin systems revisited. *Annu Rev Plant Physiol Plant Mol Biol* 51: 371–400
- Stein M, Jacquot JP, Jeannette E, Decottignies P, Hodges M, Lancelin JM, Mittard V, Schmitter JM, Miginiac-Maslow M (1995) *Chlamydomonas reinhardtii* thioredoxins: structure of the genes coding for the chloroplastic *m* and cytosolic *h* isoforms; expression in *Escherichia coli* of the recombinant proteins, purification and biochemical properties. *Plant Mol Biol* 28: 487–503
- Studier FW (1999) Use of bacteriophage T7 lysozyme to improve an inducible T7 expression system. *J Mol Biol* 219: 37–44
- Verdoucq L, Vignols F, Jacquot JP, Chartier Y, Meyer Y (1999) *In vivo* characterization of a thioredoxin *h* target protein defines a new peroxiredoxin family. *J Biol Chem* 274: 19714–19722
- Wetterauer B, Véron M, Miginiac-Maslow M, Decottignies P, Jacquot JP (1992) Biochemical characterization of thioredoxin 1 from *Dictyostelium discoideum*. *Eur J Biochem* 209: 643–649

Edited by R. Scheibe

Article numéro 6 :

**Gelhaye E, Rouhier N, Vlamis-Gardikas A, Girardet JM, Sautière PE, Sauzet M, Martin F, Jacquot JP. (2003)**

*Identification and characterization of a third thioredoxin h in poplar.*

***Plant Physiol. Biochem., sous presse.***

Afin de compléter les informations sur les thiorédoxines extra-chloroplastiques du peuplier, une troisième isoforme de Trx h nommée popTrx h3 a été clonée et surproduite dans *E. coli*. Cette isoforme diffère notablement de popTrx h2 (40% d'identité) mais elle est relativement proche de popTrx h1 au niveau de sa séquence primaire (63% d'identité). Néanmoins, son site actif (WCGPC) est différent de celui de popTrx h1 (WCPPC). Par rapport aux séquences d'*A. thaliana*, elle semble être l'isoforme équivalente de AtTrx h1. Des mutants de popTrx h1 et popTrx h3 ont été générés au niveau du site actif de manière à transformer l'un en l'autre. PopTrx h3 est réduite efficacement par la NTR d'*A. thaliana*, et c'est un meilleur donneur que popTrx h1 pour la Prx de type II de peuplier. En revanche, popTrx h3 est un donneur moins efficace que popTrx h1 pour la RNR d'*E. coli*. Ces résultats indiquent donc une certaine spécificité entre les diverses classes de Trx en dépit des homologues quelquefois élevées.

## ARTICLE IN PRESS

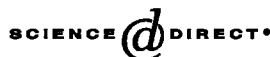
Available online at [www.sciencedirect.com](http://www.sciencedirect.com)

Plant Physiology and Biochemistry 00 (2003) 000-000

**Plant  
Physiology  
and  
Biochemistry**
[www.elsevier.com/locate/plaphy](http://www.elsevier.com/locate/plaphy)

Original article

## Identification and characterization of a third thioredoxin *h* in poplar

Eric Gelhaye <sup>a,\*</sup>, Nicolas Rouhier <sup>a</sup>, Alexios Vlamis-Gardikas <sup>b</sup>, Jean-Michel Girardet <sup>c</sup>,  
Pierre-Eric Sautière <sup>d</sup>, Michel Sauzet <sup>d</sup>, Francis Martin <sup>a</sup>, Jean-Pierre Jacquot <sup>a</sup>

<sup>a</sup> Interactions Arbres-Micro-organismes Inra, Faculté des Sciences, Université H. Poincaré-Nancy 1 (UMR 1136), 54506 Vandœuvre-les-Nancy, France

<sup>b</sup> Department of Medical Biochemistry and Biophysics, Karolinska Institutet, Medical Nobel Institute for Biochemistry, 171 77 Stockholm, Sweden

<sup>c</sup> Laboratoire des BioSciences de l'Aliment Inra, Faculté des Sciences (UC885), Université H. Poincaré-Nancy 1, 54506 Vandœuvre-les-Nancy, France

<sup>d</sup> Laboratoire d'Endocrinologie des Annélides, Université des Sciences et Technologies de Lille (UPRESA 8017), 59655 Villeneuve d'Ascq cedex, France

Received 13 December 2002; accepted 21 January 2003

### Abstract

Three full-length sequences encoding thioredoxin *h* have been isolated in a leaf/root of *Populus trichocarpa* cv. *Trichobel* expressed sequence tag (EST) library. One of these, popCXXS1 exhibits the nontypical active site CXXS homologous to atCXXS1. The second one, named popTrxh4 is related to atTrxh9 which forms with several other plant thioredoxin *h* a distinct subgroup of thioredoxins *h*. The third one, named popTrxh3, displays 66% identity and also a high degree of homology (81%) vs. the previously described popTrxh1. Nevertheless the active sites of both proteins differ, since the active site of popTrxh1 (WCPPC) is a variant of the canonical WCGPC found in popTrxh3. The cDNA sequence of popTrxh3 has been introduced in an expression plasmid (pET3d) in order to express the corresponding recombinant polypeptide. The protein has been expressed to a high level, purified from *Escherichia coli* cells with a high yield and its catalytic properties compared to popTrxh1. Furthermore two mutants, popTrxh1P40G and popTrxh3G41P have been engineered in order to explore the importance of the active site residues in the thioredoxin *h* catalytic properties. The results are discussed in relation with known biochemical properties of thioredoxins *h*.

© 2003 Éditions scientifiques et médicales Elsevier SAS. All rights reserved.

**Keywords:** Populus; Redox regulation; Recombinant; Thioredoxin *h*

### 1. Introduction

Plant thioredoxins are small molecular weight (ca. 12 kDa) and generally extremely thermostable proteins. They reduce disulfide bonds through their redox active site with the conserved sequence WC[G/P]PC. Plants possess two well-described thioredoxin systems: a cytoplasmic system including several thioredoxins *h* and a NADPH-dependent thioredoxin reductase and a specific chloroplastic system characterized by a ferredoxin-dependent thioredoxin reductase. Furthermore, two thioredoxins and a NADPH-dependent thioredoxin reductase have been described recently as a functional plant mitochondrial thioredoxin system [11].

In plants, each thioredoxin type and especially the cytosolic one, is represented by a small multigenic family. Nine thioredoxins *h* have been detected in *Arabidopsis thaliana*, three of which having the unusual active site sequence WCPPC [13,14]. In poplar, five thioredoxins *h* have also been detected ([1,5], unpublished data), the first one named popTrxh1 exhibiting the unusual active site WCPPC [1]. It has been demonstrated that the redox activity of the active center depends on amino acid residues situated between the two cysteines [3]. Among the proposed functions for cytosolic thioredoxins is the reduction of non-heme peroxidases called peroxiredoxins (Prx), which catalyze the reduction of various peroxides [15,20].

Thioredoxins have a particularly stable three-dimensional structure, which is conserved among all thioredoxin structures from prokaryotes to eukaryotic algae, higher plants, and mammals [4]. Nevertheless, yeast complementation experiments have demonstrated that *A. thaliana* thioredoxins are active only on some of the yeast thioredoxin targets [2], this specificity being probably related to the nature of the resi-

**Abbreviations:** CDP, cytidine diphosphate; DEAE, diethyl amino ethyl; DTNB, 5,5' dithiobis nitrobenzoic acid; EST, expressed sequence tag; Grx, glutaredoxin; NTR, NADPH thioredoxin reductase; Prx, peroxiredoxin; WT, wild type.

\* Corresponding author. Fax: +33-3-83-91-25-64.

E-mail address: [gelhaye@lcb.uhp-nancy.fr](mailto:gelhaye@lcb.uhp-nancy.fr) (E. Gelhaye).

ARTICLE IN PRESS

2

E. Gelhaye et al. / Plant Physiology and Biochemistry 00 (2003) 000-000

58 dues on the protein surface. It was proposed that plant thiore-  
59 doxins *h* have a common origin from a totipotent ancestor  
60 and that after gene duplications, mutations appeared masking  
61 some determinants necessary for the interaction with particu-  
62 lar targets and resulting in a specialization of the plant thiore-  
63 doxins *h* [2].

64 In this context, we have extended the characterization of  
65 the redox equipment of poplar [1,5,15,17]. We present in this  
66 paper three new nucleotidic sequences of putative thioredox-  
67 ins *h* and the characterization of one of these called pop-  
68 Trxh3. Furthermore, we have compared its biochemical  
69 properties to the previously described popTrxh1 [1] focusing  
70 on the difference observed between popTrxh1 and popTrxh3  
71 in the sequences of the active sites (WCGPC vs. WCPPC).

72 **2. Methods**

73 **2.1. Escherichia coli strains, cDNA library and plasmids**

74 *E. coli* strains DH5 $\alpha$  F' and BL21(DE3) were grown in LB  
75 medium at 37 °C supplemented with ampicillin (50  $\mu$ g ml<sup>-1</sup>).  
76 The poplar thioredoxin h3 cDNA was isolated from a  
77 xylem/phloem cDNA library of *Populus trichocarpa* cv.  
78 *Trichobel* provided by Dr. W. Boerjan and Dr. H. Meyermans  
79 (University of Ghent, Belgium) and was cloned into the  
80 expression vector pET-3d.

81 **2.2. PCR cloning**

82 Two oligonucleotides primers were constructed based on  
83 the EST (unpublished results) corresponding to a putative  
84 thioredoxin *h* full-length cDNA (369 bp) detected with the  
85 BLAST program. The upstream 24-base long oligonucle-  
86 otide was synthesized homologous to the coding strand,  
87 including an addition of six C and of a *Nco*I restriction site  
88 underlined at the 5'-end with the sequence: 5' CCC-  
89 CCCATGGCAGCAGAAGATGGA 3'. The downstream oligo-  
90 nucleotide was 27 bases long and derived from the 5'-end  
91 of the non-coding strand, featuring at the 5'-end four addi-  
92 tional C and a *Bam*HI restriction site (underlined) with the  
93 sequence: 5' CCCCCGATCCCAAGCAGAAGCAGTAGC  
94 3'. After PCR reaction performed, the amplified fragment has  
95 been purified, digested with the appropriate enzymes and  
96 cloned into the pET-3d expression plasmid as described pre-  
97 viously [16] in order to obtain the construction named pET-  
98 popTrxh3.

99 **2.3. Mutagenesis**

100 Mutagenesis of the cloned cDNAs was effected by PCR. A  
101 strategy similar to the one in [17] was employed to generate  
102 two overlapping mutated fragments and in a second PCR  
103 reaction the full-length mutated sequence. The popTrxh  
104 1P40G was obtained from pET-popTrxh1 [1] using the fol-  
105 lowing cloning oligonucleotides: direct 5' GGGGCCATG-  
106 GCCGAAGAAGGACAAGT 3'; and reverse 5'

GGGGGGATCCTTATGCAGTTGCGTGCTTTG 3'. Mu- 107  
tagenic oligonucleotides were as follows: direct 5' ACTGCT- 108  
TCATGGTGTGGACCATGTAAAATGATT 3'; and reverse 109  
5' AATCATTTTACATGGTCCACACCATGAAGCAGT 3'. 110  
The popTrxh3 mutant was obtained using the cloning oligo- 111  
nucleotides described in Section 2.2 and the mutagenic oli- 112  
gonucleotides were as follows: G41P direct 5' GCTGCT- 113  
TCATGGTGTCTCCCGTGCCGTGTCATT 3'; G41P 114  
reverse 5' AATGACACGGCACGGAGGACACCATGA- 115  
AGCAGC 3'. 116

The mutated PCR products that contained the restriction 117  
sites were cloned into the expression plasmid pET-3d, yield- 118  
ing the construction pET popTrxh1 G40P, and pET popTrxh3 119  
G41P. The sequences of the recombinant plasmids were 120  
verified by DNA sequencing. 121

2.4. Expression and purification of the recombinant 122  
proteins 123

All procedures for the expression and purification of *A.* 124  
*thaliana* NADPH Trx reductase, poplar Trxh1 and poplar Prx 125  
are described elsewhere [1,9,15]. For the expression of 126  
popTrxh1p40G, and popTrxh3 WT, the recombinant plas- 127  
mids were used to transform *E. coli* BL21(DE3) strain. One 128  
colony was used to inoculate 3 ml LB medium, suppl- 129  
mented with ampicillin. The culture was successively ampli- 130  
fied to a final volume of 3 l over a period of 24 h and induced 131  
with 100  $\mu$ M IPTG for 6 h. The cells were then collected by 132  
centrifugation and suspended in TE buffer (30 mM Tris-HCl, 133  
1 mM EDTA, pH 8). The cell suspension was disrupted by 134  
sonication. The resulting sample was fractionated with am- 135  
monium sulfate. The fraction precipitating between 40% and 136  
80% of the saturation was suspended in a minimal volume of 137  
TE buffer. The purification was then performed as described 138  
previously [1] using Sephadex G50 gel filtration and DEAE- 139  
Sephacrose columns. 140

The last purification step was performed by size exclusion 141  
chromatography. A volume of 100  $\mu$ l protein (5.5 mg ml<sup>-1</sup>) 142  
obtained as described above was loaded on a Superose 12HR 143  
column connected to a fast protein liquid chromatography 144  
(FPLC) system. The column was equilibrated with 30 mM 145  
Tris-HCl (pH 8) buffer containing 0.15 M NaCl and the 146  
proteins were eluted in the same buffer at a flow rate of 0.25 147  
ml min<sup>-1</sup>. 148

2.5. Enzymatic activities 149

The reduction of H<sub>2</sub>O<sub>2</sub> by poplar Prx in the presence of 150  
different popTrxh was followed spectrophotometrically us- 151  
ing a Cary 50 spectrophotometer as described previously 152  
[15]. The reduction of thioredoxin by NADPH and the re- 153  
combinant *A. thaliana* NADPH-thioredoxin reductase was 154  
followed at 412 nm using DTNB as a substrate [10]. Reduc- 155  
tion of cytidine diphosphate (CDP) by *E. coli* RR1a was 156  
performed essentially as described in [6]. Reducing power 157  
was provided by 2 mM DTT. All assays were performed in a 158  
total volume of 120  $\mu$ l. The catalytic effect of the thioredox- 159

ARTICLE IN PRESS

E. Gelhaye et al. / Plant Physiology and Biochemistry 00 (2003) 000-000

3



Fig. 1. Amino acid comparison of poplar thioredoxins *h*. The sequence are from *P. trichocarpa* cv. *Trichobel* (pop), popTrxh1 (AF483265), popTrxh2 (AF483266), *A. thaliana* (at), atTrxh1 (CAA78462), atTrxh2 (Z35474), atTrxh3 (CAA84611), atTrxh4 (CAA84613), atTrxh5 (CAA84610), atTrxh7 (NM104666), atTrxh8 (NM105656), atCXXS1 (AF144390), atCXXS2 (ATU35639). Conserved amino acids in all the sequences are white, amino acids with similar biochemical properties are bold, and dashes represent gaps introduced to optimize the alignment.

160 ins is presented as total CDPs reduced in 20 min at 37 °C.  
 161 Values represent the means of two independent measure-  
 162 ments and error bars ± 1S.E.

163 2.6. Formation of heterodimers

164 The formation of heterodimer between Prx and Trx has  
 165 been described previously [14]. Briefly, 1.25 µg of Prx and  
 166 popTrxh3 previously reduced (1 mM DTT) were mixed in  
 167 the presence of TE buffer (30 mM Tris-HCl, 1 mM EDTA,  
 168 pH 8) to a final of 10 µl. This reaction mixture was incubated  
 169 at room temperature for 2-3 min before the addition of 10  
 170 mM diamide. The mixture was incubated at room tempera-  
 171 ture for 20 min and then subjected to 14% SDS-PAGE in the  
 172 presence of an equivalent of non-reducing sample buffer (0.5  
 173 M Tris-HCl, pH 6.8, 4% SDS, 20% glycerol, and bromophe-  
 174 nol blue).

175 2.7. Thermostability

176 Aliquots of thioredoxin at a concentration of 50 µM were  
 177 heated at 99 °C in TE buffer during various incubation times.  
 178 After heating the fractions were immediately cooled 1 min  
 179 on ice and centrifugated for 5 min at 13 000 rpm to precipi-  
 180 tate denatured protein, if any. Aliquots of the supernatant  
 181 were used to perform the DTNB reduction in presence of  
 182 NTR.

3. Results and discussion

3.1. Sequences analysis

Using the BLAST program, we have identified several  
 sequences for thioredoxin *h* in the leaf/root poplar expressed  
 sequence tag (EST) library (F. Martin, unpublished results).  
 Three of these sequences correspond to putative full-length  
 thioredoxins *h* called popTrxh3, popTrxh4 and popCXXS1  
 in this study.

A multiple alignment performed with Clustal W [19]  
 shows conserved amino acids in *A. thaliana* thioredoxin *h*  
 and poplar thioredoxins *h* (Fig. 1). Poplar as well as *A.*  
*thaliana* thioredoxins *h* contain the conserved N-terminus  
 tryptophan residue (W17), which is a signature of the thio-  
 redoxin *h* sequences (W13 in *Chlamydomonas reinhardtii*)  
 [12,18]. Among the five poplar thioredoxin *h* sequences,  
 three present the classical sequence WCGPC in the active  
 site, whereas popTrxh1 exhibits a WCPCP site. PopCXXS1  
 exhibits the nontypical active site CXXS, this active site  
 being not compatible with typical thioredoxin activity [13]. It  
 has been postulated that this kind of protein could act as  
 disulfide isomerase and possibly as a reductase [13].

All known poplar thioredoxins *h* are members of the  
 groups defined with *A. thaliana* sequences. Indeed, a phylo-  
 genic tree produced on the basis of sequence similarity shows  
 that poplar thioredoxins are members of previously de-  
 scribed *A. thaliana* thioredoxins classes (Fig. 2). PopTrxh4 is

183

184

185

186

187

188

189

190

191

192

193

194

195

196

197

198

199

200

201

202

203

204

205

206

207

208

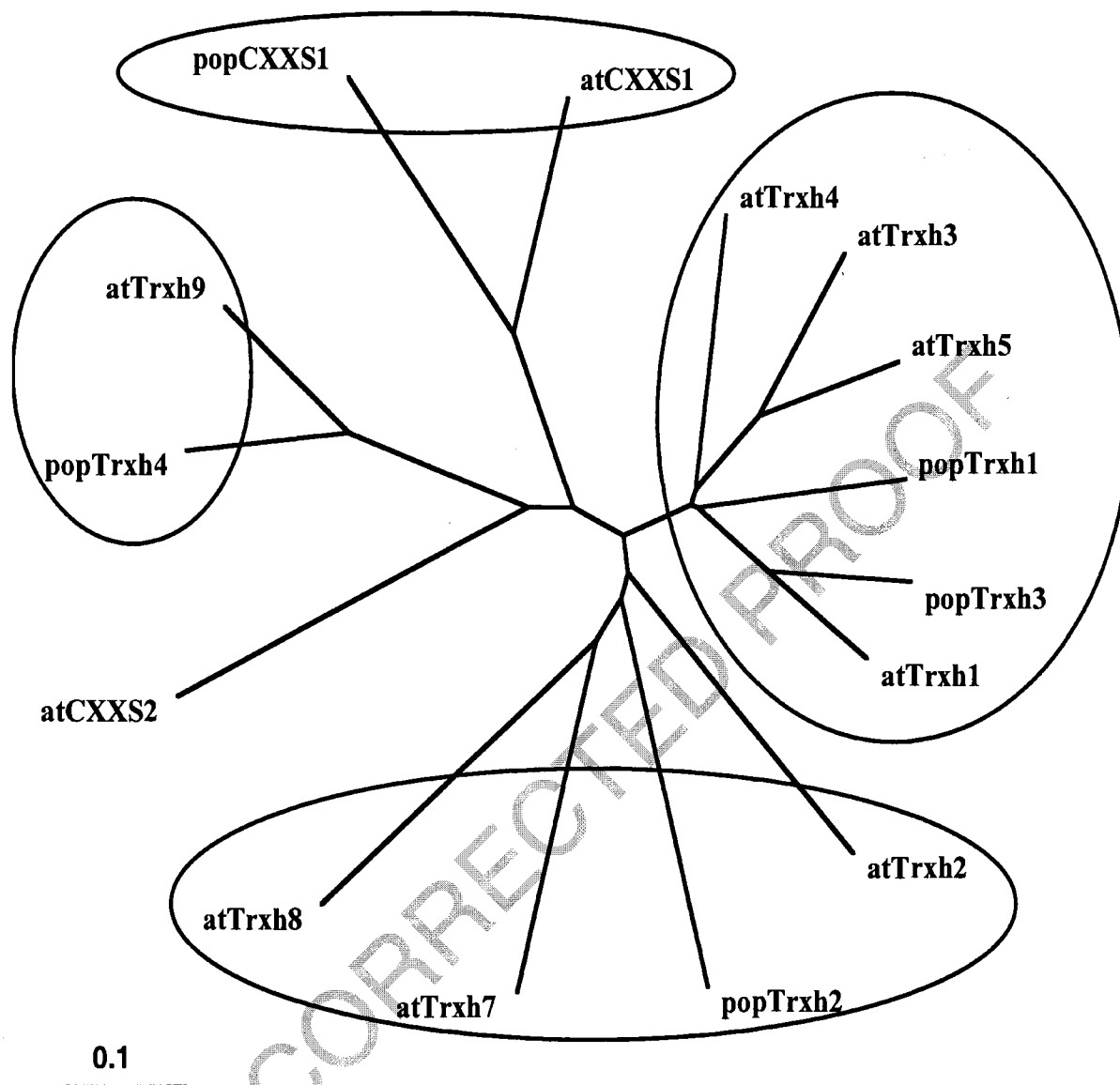

Fig. 2. Phylogenetic tree of *P. trichocarpa* cv. *Trichobel* and *A. thaliana* thioredoxins *h*. Each thioredoxin is named in Fig. 1.

209 related to atTrxh9, which forms with several other plant  
 210 thioredoxins *h* a distinct subgroup of thioredoxins *h* as pro-  
 211 posed previously [13]. PopCXXS1 is associated with  
 212 atCXXS1 in other subgroup, sharing also this unusual active  
 213 site as well as sequence homology. Nevertheless, atCXXS2  
 214 is not in this subgroup despite the active site homology.  
 215 Interestingly, the extended popTrxh2 is associated with at-  
 216 Trxh2, atTrxh7 and atTrxh8 in a particular subgroup, all  
 217 members of this subgroup having a N-terminal amino acid  
 218 extension. The significance of this particularity remains un-  
 219 clear but could be important for the physiological role of  
 220 these thioredoxins. PopTrxh1 and popTrxh3 are associated

with the classic *Arabidopsis* thioredoxins *h* (h1, h3, h4, and  
 h5). Nevertheless, popTrxh3 is closely associated with at-  
 Trxh1, which harbors the same classical active site WCGPC,  
 while popTrxh1 is between the above thioredoxins. The other  
 three *Arabidopsis* thioredoxins (atTrxh3, h4 and h5) exhibit-  
 ing the WCPPC active site are more closely related. Poplar  
 Trxh3 displays 66% identity and also a high degree of homology  
 (81%) vs. popTrxh1, nevertheless the active sites of both  
 proteins differ since the active site of popTrxh1 (WCPPC) is  
 a variant of the canonical WCGPC found in popTrxh3. In this  
 context, we decided to compare the biochemical properties  
 of both popTrxh.

221  
 222  
 223  
 224  
 225  
 226  
 227  
 228  
 229  
 230  
 231  
 232

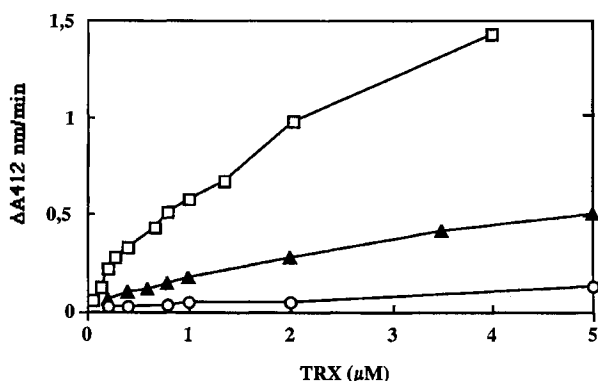

Fig. 3. Activity of different thioredoxins determined by the DTNB reduction assay. Various amounts of oxidized thioredoxins were incubated in the presence of 77.5 nM NTR, 150 μM NADPH, 100 μM DTNB in buffer 30 mM Tris-HCl (pH 8.0). DTNB reduction was measured at 412 nm as absorbance change per min. (○), popTrh1 P40G; (▲), popTrxh1; (□), popTrxh3.

### 233 3.2. Expression of the recombinant protein popTrxh3 234 and purification

235 The corresponding cDNA of poptrxh3 has been cloned by  
236 PCR and inserted into the expression plasmid pET-3d, yield-  
237 ing the construction pET-Trxh3. The open reading frame  
238 consists of 369 nucleotides coding for a polypeptide of 122  
239 amino acids.

240 The pET-Trxh3 plasmid was used to transform the *E. coli*  
241 expression strain BL21(DE3). The protein was purified using  
242 two chromatographic steps consisting of a G50 gel filtration  
243 column followed by a diethyl amino ethyl (DEAE)-Sephacel  
244 ion exchange. After SDS-PAGE analysis the obtained prepara-  
245 tion showed unexpectedly two distinct bands with apparent  
246 molecular masses of about 14 and 28 kDa, respectively. The  
247 first value is in close agreement with the predicted mass of  
248 the polypeptide (13 345 Da). The 28 kDa polypeptide could  
249 correspond to a homodimer of the protein or result from a  
250 contamination. The separation of both polypeptides was per-  
251 formed by size exclusion fast liquid chromatography on a  
252 superose 12 column. The N-terminal sequence analysis of  
253 the 14 kDa polypeptide confirmed the presence of popTrxh3  
254 (AAEDGQ). The N-terminal sequence analysis of 28 kDa  
255 polypeptide indicated the presence β-lactamase, the protein  
256 responsible of the ampicillin resistance (HPETLVKVKD)  
257 excluding the possibility to have significant amounts of a  
258 thioredoxin dimer.

### 259 3.3. Catalytic properties and mutagenesis of the active site

260 One of the most widely used tests for the detection of Trx  
261 activity is the reduction of 5,5' dithiobis nitrobenzoic acid  
262 (DTNB) in the presence of the NADPH thioredoxin reduc-  
263 tase (NTR)-dependent reduction system (Fig. 3). Interest-  
264 ingly, the recombinant popTrxh3 is very efficient in this test  
265 which indicates that it is readily reduced by the NADPH-  
266 dependent thioredoxin reductase. The apparent  $K_M$  calcula-  
267 ted from these experiments is around 0.5 μM, which is

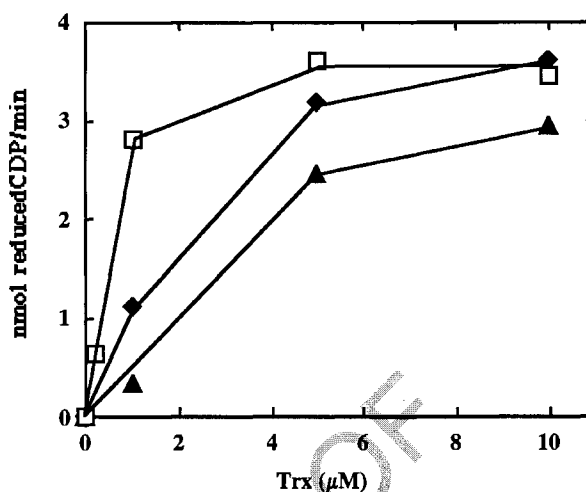

Fig. 4. Activity of popPrx in presence of different thioredoxins. Various amounts of oxidized thioredoxins were incubated in the presence of 77.5 nM NTR, 150 μM NADPH, 500 μM H<sub>2</sub>O<sub>2</sub>, 5 μM popPrx. NADPH oxidation was measured at 340 nm as absorbance change per min. (○), popTrh1 P40G; (▲), popTrxh1; (□), popTrxh3.

268 significantly lower than the value observed with popTrxh1 268  
269 (around 4 μM). Since popTrxh1 possesses a WCPC active 269  
270 site, which could explain this difference, a P40G mutant of 270  
271 popTrxh1 (active site modified to WCGPC) was produced in 271  
272 *E. coli*, purified and its activity tested. Unexpectedly, replac- 272  
273 ing Pro40 by a glycine residue has a strong effect on the 273  
274 activity, since the apparent  $K_M$  observed with the G40P 274  
275 mutation increases to around 90 μM. 275

276 To complete this work, the active site of popTrxh3 has also 276  
277 been modified producing the mutant protein popTrxh3G41P 277  
278 possessing the following active site: WCPC. This G41P 278  
279 mutant was also produced in *E. coli*. The mutation modifies 279  
280 dramatically the properties of the protein. It increases the 280  
281 apparent hydrophobicity of the protein since it precipitated at 281  
282 a concentration of 40% ammonium sulfate, while the wild 282  
283 type (WT) precipitated between 40% and 80%. Furthermore, 283  
284 the SDS-PAGE migration of G41P is altered since its appar- 284  
285 ent molecular weight is around 18 kDa. In addition, the 285  
286 recombinant protein was eluted throughout the G50 gel fil- 286  
287 tration separation domain demonstrating an aggregation of 287  
288 the mutated protein, which prevented complete purification. 288  
289 The partially purified popTrxh3G41P exhibits only a very 289  
290 weak residual activity using the NTR dependent reduction 290  
291 system. 291

292 It has been demonstrated recently that a poplar type II Prx 292  
293 is able to use both Trx and glutaredoxin (Grx) as proton 293  
294 donors [15,16]. It was thus of interest to test the efficiency of 294  
295 both popTrx h in the reduction of popPrx. Fig. 4 shows the 295  
296 results of those experiments. In this test, popTrxh3 allows a 296  
297 better hydrogen peroxide (H<sub>2</sub>O<sub>2</sub>) reduction than popTrxh1. 297  
298 Nevertheless the reaction rate saturates at about 15 μM what- 298  
299 ever the thioredoxin used. 299

300 Experiments of covalent heterodimer formation between 300  
301 popPrx and popTrxh3 have been performed in presence of 301

ARTICLE IN PRESS

6

E. Gelhaye et al. / Plant Physiology and Biochemistry 00 (2003) 000-000

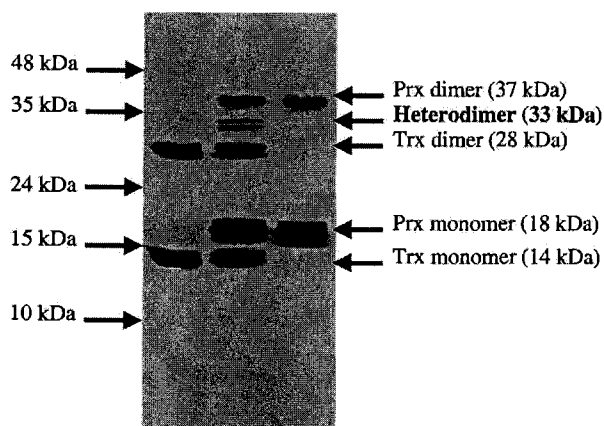

Fig. 5. Formation of heterodimers between popTrxh3 and popPrx. Non-reducing 14% SDS-PAGE showing Prx incubated with popTrxh3 in presence of diamide. Arrows indicate the position of the monomeric enzymes and the dimers.

302 diamide as previously described [16]. Fig. 5 shows the result  
 303 of this association. The popTrxh3 molecule is present with  
 304 apparent molecular masses of 14 kDa corresponding to the  
 305 monomer and the popPrx is present with the usual doublet at  
 306 about 18 kDa. By running the proteins individually and based  
 307 on the molecular mass determination, we could assess the  
 308 additional polypeptides as follows: the 33-kDa polypeptide  
 309 is likely a heterodimer between one molecule of Trx and one  
 310 molecule of Prx, the 28-kDa polypeptide is a Trx dimer and  
 311 the 37-kDa polypeptide is a Prx dimer [16]. The heterodimer  
 312 also generated in presence of diamide can be reduced in the  
 313 presence of excess dithiothreitol (data not shown). The dis-  
 314 appearance of the heterodimer polypeptide after reduction  
 315 confirms that the two chains are indeed linked together via a  
 316 disulfide bond. These data suggest that popTrxh3 is able to  
 317 create stable association with popPrx.

318 To examine the possible involvement of both thioredoxins  
 319 in the reduction of ribonucleotides, we examined their reac-  
 320 tivity with RR1a from *E. coli* [6]. To overcome the problems  
 321 of specificity that might have arisen if *E. coli* thioredoxin  
 322 reductase and NADPH would have been used, these experi-  
 323 ments were performed in the presence of DTT. The plant  
 324 thioredoxins were much less active in the reduction of *E. coli*  
 325 RR1a when compared to the *E. coli* homologous enzyme  
 326 (Fig. 6). PopTrxh3 was more active than popTrxh1 in this in  
 327 vitro experiment, nevertheless the reaction rates saturates at  
 328 about 5  $\mu$ M whatever the plant thioredoxin used.

329 3.4. Thermostability

330 One interesting feature of popTrxh1 is the thermal stabil-  
 331 ity of this protein compared to *C. reinhardtii* thioredoxin [1].  
 332 Given the high homology between both popTrx h, it was of  
 333 interest to determine whether popTrxh3 exhibits the same  
 334 thermostability as popTrxh1. Both proteins are able to con-  
 335 serve a biological activity even after 10 min heating at 99 °C,  
 336 nevertheless popTrxh1 is slightly more thermostable than  
 337 popTrxh3 (respectively around 30% and 15% of initial

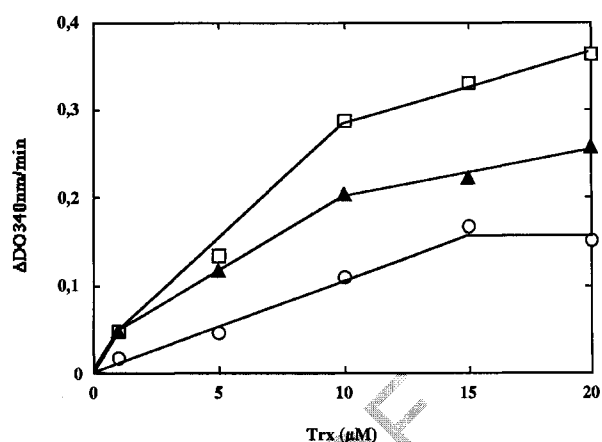

Fig. 6. CDP reduction by *E. coli* ribonucleotide reductase. The reduction of CDP by *E. coli* RNR1a was tested in the presence of DTT and various concentrations of *E. coli* Trx1 ( $\square$ ), popTrxh1 ( $\blacktriangle$ ) or popTrxh3 ( $\blacklozenge$ ).

DTNB reduction in presence of NTR). The molecular basis 338  
 of this difference in the heat stability remains to be eluci- 339  
 dated. 340

4. Conclusion 341

342 Thioredoxins have a highly conserved three-dimensional 342  
 structure and participate in multiple reactions, which require 343  
 reduction of disulfide bonds on selected target proteins. The 344  
 significance of the high number of thioredoxins *h* found in 345  
 higher plants remains unclear, since each individual thiore- 346  
 doxin *h* characterized so far allows the transduction of a 347  
 redox signal from NTR to target proteins without specificity. 348  
 The redox potentials of these catalysts depend on both the 349  
 nature of the amino acid present between the two catalytic 350  
 cysteine residues and the surrounding amino acid residues 351  
 [2]. In this work, we have characterized a novel cytosolic 352  
 thioredoxin from poplar called popTrxh3. It is very homolo- 353  
 gous to the previously described popTrxh1 (81% of homolo- 354  
 gy) [1], nevertheless both thioredoxins differ in their active 355  
 site since popTrxh1 exhibits the atypical site WCPPC. Both 356  
 recombinant proteins exhibit differences in their ability to be 357  
 reduced by the NTR from *A. thaliana*, popTrxh3 being more 358  
 active than popTrxh1. In popTrxh3, the single mutation 359  
 G41P alters the conformation of the molecule leading to an 360  
 inactive protein. Similarly, when the active site of popTrxh1 361  
 was modified into WCGPC, the activity of the resulting 362  
 protein is dramatically reduced. It has been shown in atTrxh3 363  
 that the modification of the active site WCPPC into WCGPC 364  
 allows the molecule to restore sulfate assimilation during 365  
 yeast complementation experiments [2]. Our results on pop- 366  
 lar thioredoxins suggest that the amino acid located at the 367  
 C-terminal side of the catalytic cysteine residue is of course 368  
 important for the catalytic activity but also essential to main- 369  
 tain an active conformation in the case of popTrxh3. The 370  
 ancestral mutation leading to the transformation of the active 371  
 site from WCGPC to WCPPC in popTrxh1 must have been 372



373 accompanied by other mutation(s) involving surrounding  
374 amino acids and stabilizing the protein in an active confor-  
375 mation.

376 It has been demonstrated that a rice thioredoxin *h* is  
377 present in the phloem sieve tubes [7]. This thioredoxin is  
378 synthesized in the companion cells prior to being transferred,  
379 through plasmodesmata, to the enucleate sieve-tube mem-  
380 bers. Several structural motifs are critical for this cell-to-cell  
381 movement, particularly the N-terminal following sequence  
382 MAAEE and a motif RKDD situated in the C-terminal area  
383 [8]. Interestingly, the amino acid sequence of popTrxh3 also  
384 begins by MAAEE and possesses a motif R<sub>104</sub>KDE<sub>107</sub> highly  
385 homologous to the R<sub>101</sub>KDD<sub>104</sub> motif in the C-terminal area  
386 of rice thioredoxin *h*. This homology suggests then a possible  
387 phloem localization of popTrxh3 as well as a putative cell-  
388 to-cell transfer of this protein. The confirmation of this hy-  
389 pothesis requires further experiments studying subcellular  
390 and tissue localization of this protein.

#### 391 References

392 [1] M. Behm, J.P. Jacquot, Isolation and characterization of thioredoxin *h*  
393 from poplar xylem, *Plant Physiol. Biochem.* 39 (2000) 363–369.  
394 [2] C. Brehelin, N. Mouaheb, L. Verdoucq, J.M. Lancelin, Y. Meyer,  
395 Characterization of determinants for the specificity of *Arabidopsis*  
396 thioredoxins *h* in yeast complementation, *J. Biol. Chem.* 275 (2000)  
397 31641–31647.  
398 [3] P.T. Chivers, R.T. Raines, General acid/base catalysis in the active site  
399 of *Escherichia coli* thioredoxin, *Biochemistry* 36 (1997)  
400 15810–15816.  
401 [4] S. Dai, C. Schwendtmayer, K. Johansson, S. Ramaswamy, P. Schur-  
402 mann, H. Eklund, How does light regulate chloroplast enzymes?  
403 Structure-function studies of the ferredoxin/thioredoxin system, *Q.*  
404 *Rev. Biophys.* 33 (2000) 67–108.  
405 [5] E. Gelhaye, N. Rouhier, P. Laurent, P.E. Sautiere, F. Martin, J.P. Jac-  
406 quot, Isolation and characterization of an extended thioredoxin *h* from  
407 poplar, *Physiol. Plant.* 114 (2002) 165–171.  
408 [6] A. Holmgren, Glutathione-dependant synthesis of deoxyribonucle-  
409 otides. Characterization of the enzymatic mechanism of *Escherichia*  
410 *coli* glutaredoxin, *J. Biol. Chem.* 254 (1978) 3672–3678.  
411 [7] Y. Ishiwatari, C. Honda, I. Kawashima, S.I. Nakamura, H. Hirano,  
412 S. Mori, T. Fujiwara, H. Hayashi, M. Chino, Thioredoxin *h* is one  
413 major proteins in rice phloem sap, *Planta* 195 (1995) 463–465.

[8] Y. Ishiwatari, T. Fujiwara, K.C. McFarland, K. Nemoto, H. Hayashi, 414  
M. Chino, W.J. Lucas, Rice phloem thioredoxin *h* has the capacity to 415  
mediate its own cell-to-cell transport through plasmodesma, *Planta* 416  
205 (1998) 12–22. 417  
[9] J.P. Jacquot, R. Rivera-Madrid, P. Marinho, M. Kollarova, P. Le 418  
Marechal, M. Miginiac-Maslow, Y. Meyer, *Arabidopsis thaliana* 419  
NAPHP thioredoxin reductase. cDNA characterization and expres- 420  
sion of the recombinant protein in *Escherichia coli*, *J. Mol. Biol.* 235 421  
(1994) 1357–1363. 422  
[10] J.P. Jacquot, E. Issakidis, P. Decottignies, M. Lemaire, M. Miginiac- 423  
Maslow, Analysis and manipulation of target enzymes for thioredoxin 424  
control, *Methods Enzymol.* 252 (1995) 240–252. 425  
[11] C. Laloï, N. Rayapuram, Y. Chartier, J.M. Grienerberger, G. Bonnard, 426  
Y. Meyer, Identification and characterization of a mitochondrial 427  
thioredoxin system in plants, *Proc. Natl. Acad. Sci. USA* 98 (2001) 428  
14144–14149. 429  
[12] S.D. Lemaire, J.M. Richardson, A. Goyer, E. Keryer, J.M. Lancelin, 430  
G.I. Makhatadze, J.P. Jacquot, Primary structure determinants of the 431  
pH- and temperature-dependent aggregation of thioredoxin *h*, *Bio-* 432  
*chim. Biophys. Acta* 1476 (2000) 311–323. 433  
[13] Y. Meyer, F. Vignols, J.P. Reichheld, Classification of plant thioredox- 434  
ins by sequence similarity and intron position, *Methods Enzymol.* 347 435  
(2002) 394–402. 436  
[14] R. Rivera-Madrid, D. Mestres, P. Marinho, J.P. Jacquot, P. Decot- 437  
tignies, M. Miginiac-Maslow, Y. Meyer, Evidence for five divergent 438  
thioredoxin *h* sequences in *Arabidopsis thaliana*, *Proc. Natl. Acad.* 439  
*Sci. USA* 92 (1995) 5620–5624. 440  
[15] N. Rouhier, E. Gelhaye, P.E. Sautiere, A. Brun, P. Laurent, D. Tagu, 441  
J. Gerard, E. de Fay, Y. Meyer, J.P. Jacquot, Isolation and character- 442  
ization of a new peroxiredoxin from poplar sieve tubes that uses either 443  
glutaredoxin or thioredoxin as a proton donor, *Plant Physiol.* 127 444  
(2001) 1299–1309. 445  
[16] N. Rouhier, E. Gelhaye, J.P. Jacquot, Glutaredoxin-dependent perox- 446  
iredoxin from poplar: protein-protein interaction and catalytic mecha- 447  
nism, *J. Biol. Chem.* 277 (2002) 13609–13614. 448  
[17] N. Rouhier, E. Gelhaye, J.P. Jacquot, Exploring the active site of plant 449  
glutaredoxin by site-directed mutagenesis, *FEBS Lett.* 511 (2002) 450  
145–149. 451  
[18] M. Stein, J.P. Jacquot, E. Jeannette, P. Decottignies, M. Hodges, 452  
J.M. Lancelin, V. Mittard, J.M. Schmitter, M. Miginiac-Maslow, 453  
*Chlamydomonas reinhardtii* thioredoxins: structure of the genes cod- 454  
ing for the chloroplastic *m* and cytosolic *h* isoforms; expression in 455  
*Escherichia coli* of the recombinant proteins, purification and bio- 456  
chemical properties, *Plant Mol. Biol.* 28 (1995) 487–503. 457  
[19] J.D. Thompson, F. Plewniak, O. Poch, A comprehensive comparison 458  
of multiple sequence alignment programs, *Nucleic acid Res.* 27 459  
(1999) 2682–2690. 460  
[20] L. Verdoucq, F. Vignols, J.P. Jacquot, Y. Chartier, Y. Meyer, In vivo 461  
characterization of a thioredoxin *h* target protein defines a new 462  
peroxiredoxin family, *J. Biol. Chem.* 274 (1999) 19714–19722. 463

Article numéro 7 :

**Rouhier N, Gelhaye E, Sautière PE, Jacquot JP. (2002)**

*Enhancement of poplar glutaredoxin expression by optimization of the cDNA sequence.*

**Protein Expr Purif. 24(2): 234-41.**

Cet article décrit l'isolement d'une Grx bicystéinique de 139 acides aminés homologue à la Grx CxxC4 d'*A. thaliana* (Tableau I et Figure 9) ainsi que les modifications de la séquence nucléotidique effectuées pour optimiser l'expression de la protéine recombinante chez *E. coli*. En effet, la séquence initialement reconstituée à partir de séquence EST était tronquée en C-terminal de 14 acides aminés. De plus, cette séquence code pour une protéine qui possède une extension N-terminale d'environ 27 acides aminés par rapport aux séquences fonctionnelles de Grx préalablement caractérisées. Quelles que soient les modifications envisagées, la protéine de 139 acides aminés n'a jamais pu être exprimée chez *E. coli*. Toutefois, ce travail nous a permis de réaliser l'importance des codons initiaux pour l'efficacité de la traduction d'une séquence chez *E. coli*. Ainsi, l'existence de ce biais de codon chez *E. coli* c'est à dire que certains codons sont peu utilisés du fait de la faible représentativité des ARNt correspondant, est à prendre en compte lorsqu'on veut exprimer une séquence chez *E. coli*. En effet, en fonction de leur position dans la séquence codante, deux des codons codant pour l'arginine, AGG et AGA, sont réellement défavorables à une expression efficace de la protéine recombinante chez *E. coli*. Ce problème peut être contourné en utilisant le plasmide pSBET qui code pour l'ARNt reconnaissant ces deux codons AGG et AGA. Enfin, l'activité de cette Grx a été démontrée envers un substrat artificiel le HED (hydroxyethyl disulfide) et le DHA (déhydroascorbate).



## Enhancement of Poplar Glutaredoxin Expression by Optimization of the cDNA Sequence

Nicolas Rouhier,\* Eric Gelhaye,\* Pierre-Eric Sautière,† and Jean-Pierre Jacquot\*.<sup>1</sup>

\*Unité Mixte de Recherche 1136 IaM (Interaction Arbres Microorganismes), INRA-UHP Nancy I. Université Henri Poincaré, 54506 Vandœuvre Cedex. France; †Laboratoire d'Endocrinologie des Annélides UPRESA 8017, Université des Sciences et Technologies de Lille, 59655 Villeneuve d'Ascq Cedex, France

Received July 26, 2001, and in revised form October 26, 2001

Glutaredoxins are low-molecular-weight oxidoreductases that play an important role in redox regulation in eukaryotic and prokaryotic cells. Because of their low abundance, these proteins are poorly characterized in plants. Furthermore, very poor yields have been obtained with the expression systems prepared so far, and in addition, the recombinant products contain a His-tag which can interfere with the biochemical characterization. In order to obtain more information about those important regulatory proteins in plants, a cDNA coding for an extended glutaredoxin has been introduced into the expression plasmid pET-3d and the resulting construction has been used to transform *Escherichia coli* strain BL21(DE3) in the presence of plasmid helper pSBET or not. Initially poor or ineffective protein expression has been improved by successively cloning a N-terminus truncated form of the protein, introducing silent mutations both at the 5' and at the 3' ends of the nucleotide sequence, and finally altering the 3' end in order to change the C-terminus amino acid sequence of the protein. The first modifications have allowed us to produce the protein in large amounts but essentially in an insoluble form which could be resolubilized and purified. On the other hand, changing the C-terminus sequence resulted in protein preparations of high purity and in a soluble form. The recombinant proteins were biochemically active and the yield varied between 6 and 14 mg of homogeneous protein per liter of culture. © 2002 Elsevier Science (USA)

In the past years, the study of redox reactions involving the reduction of disulfide bridges has received ever more attention. It appears that maintaining a reduced intracellular state is essential to fight against an oxidizing extracellular environment and reactive oxygen species which are the product of normal aerobic metabolism. Indeed, the oxidation of proteins can lead to their inactivation and to cellular dysfunction (1). The thiol disulfide oxidoreductases, which regroup proteins such as thioredoxins (Trx),<sup>2</sup> glutaredoxins (Grx) (originally named thioltransferase or transhydrogenase), protein disulfide isomerases (PDI), and nucleoredoxins are present in all living organisms and are necessary for the maintaining of a proper redox state (2–4). While Trx and Grx are effective reductants, PDI is clearly an oxidant whose function is to create disulfide bridges. All the above-mentioned proteins possess a conserved active site C-X-X-C, required for their activities and a similar basic structural fold called the thioredoxin fold.

Glutaredoxin can be differentiated from the other above-mentioned catalysts by the amino acid sequence of its active site [CP(Y/F)C] that is highly conserved among species. In *Escherichia coli*, glutaredoxins vary in size between 82 and 215 amino acids, but in most other species, the medium size is of ca. 100 amino acids with a molecular weight of around 11 kDa (5). Grx is selectively reduced via NADPH, through a flavoprotein glutathione reductase and reduced glutathione (6). In prokaryotic and animal cells, Grx acts as a reductant for many enzymes including ribonucleotide reductase

<sup>1</sup> To whom correspondence should be addressed. E-mail: j2p@scbiol.uhp-nancy.fr.

<sup>2</sup> Abbreviations used: DHA, dehydroascorbate; Grx, glutaredoxin; HED, hydroxyethyl disulfide; Trx, thioredoxins; PDI, protein disulfide isomerases; LB, Luria-Bertani; DTT, dithiothreitol; EST, expressed sequence tag.

(7) and PAPS reductase (8). It is also implicated in the reduction of arsenate to arsenite by arsenate reductase in *E. coli* (9) and of dehydroascorbate to ascorbate in mammals (10). Grx can also activate transcription factors such as OxyR (11, 12), PEBP2 (polyoma virus enhancer binding protein 2) (13), or NF1 (nuclear factor 1) (14). It seems thus that this protein participates in cell transduction cascades through the redox regulation of these transcription factors.

A specificity of Grx is its involvement in protein glutathiolation processes. Indeed, an oxidative stress can induce a reversible oxidation of cysteine residues into sulfenic acid or an irreversible oxidation into sulfonic or sulfinic acids. A mixed disulfide bridge between a given target protein and glutathione could prevent irreversible oxidation of an active-site cysteine residue. As Grx can efficiently perform protein deglutathiolation, it could play a major role in the regulation and maintenance of protein activities (15, 16).

In plants, little is known about the function of Grx. It has been demonstrated in rice that Grx is one of the major polypeptides of the phloem sap which suggests that it could play a role in the signal transduction mechanism over long distances (17). It has also been observed that Grx is present in *Spinacia oleracea* leaves (18) or in the aleurone layer from *Oryza sativa* (19) where it could act as a protector against oxygen radicals. Nevertheless, all these observations remain rather sketchy, essentially because this protein is present in low amounts and the previous expression systems gave rather poor yields. Furthermore, the target proteins of Grx in plants are not known. In order to gather more biochemical information about the function and structure of glutaredoxins in plants, we have decided to investigate this problem using poplar as a starting material. One of the reasons for this choice is that there are absolutely no data concerning the presence and the function of this type of protein in woody species in contrast to herbaceous species. Poplar is indeed the preferred model for woody species, since it is a tree of economic interest and it is amenable to transformation. As the protein is present in very low amounts in poplar, we had to turn to genetic engineering in order to obtain the protein in sufficient yield for further biochemical and structural analyses. We describe in this paper the strategy used to optimize the production of a poplar Grx devoid of His-tag in *E. coli* through the manipulation of its cDNA sequence.

## MATERIALS AND METHODS

### *E. coli* Strains, cDNA Library, and Plasmid

*E. coli* strains DH5 $\alpha$ F' and BL21(DE3) were grown on LB medium at 37°C supplemented with ampicillin (50  $\mu$ g/mL). The glutaredoxin cDNA was isolated from a xylem/phloem cDNA library of *Populus trichocarpa*

cv. trichobel provided by Drs. W. Boerjan and H. Meyer-mans (University of Ghent, Belgium) and was cloned into the expression vector pET-3d.

### PCR Cloning

The different primers were designed based on plant glutaredoxin amino acid comparisons and available ESTs (Accession Nos. AI166603 and AI162979). Upstream oligonucleotides are homologous to the coding strand and possess a *Nco*I restriction site. Reverse oligonucleotides are complementary to the 5' end of the noncoding strand and contain a *Bam*HI restriction site. All primers used throughout this work are displayed in Table 1. PCR reactions were effected on the xylem/phloem cDNA library (2.5  $\mu$ L with a titer of 5.10<sup>5</sup> phages/mL), in 100  $\mu$ L of the reaction medium containing 200 nM each primer, 2.5 mM MgCl<sub>2</sub>, 200 nM dNTPs, and 1 unit of Goldstar DNA polymerase (Eurogentec, Seraing, Belgium). The reaction mixture was first submitted to an initial denaturation step of 3 min at 95°C and then to 35 cycles (1 min at 95°C, 2 min at 52°C, and 3 min at 72°C) followed by a final elongation step of 10 min at 72°C. The amplified fragments were then purified by the GFX PCR DNA and gel band purification kit from Amersham Pharmacia Biotech (Uppsala, Sweden), digested with the appropriate restriction enzymes, and cloned into the pET-3d expression plasmid which was then called pET-Grx.

### Glutaredoxin Expression and Purification

*E. coli* BL21(DE3) cells containing or not the plasmid pSBET (20) were transformed with the recombinant expression plasmid pET-Grx. One ampicillin- (and kanamycin when needed) resistant colony was grown in 3 mL and progressively brought up to 5 L at 37°C. Once the exponential phase was reached, the cultures were induced for 4 h with 100  $\mu$ M isopropyl thiogalactoside (Eurogentec). Bacteria were then pelleted by centrifugation at 4400g and resuspended in a minimal volume of TE (30 mM Tris-HCl, pH 8, 1 mM EDTA) buffer (typically 70 mL final/5 L culture). Samples were sonicated on ice with the Sonicator Ultrasonic processor XL from Misonix (Farmingdale, NY) for 3 min. Extracts were precipitated between 40 and 90% of ammonium sulfate saturation and the resulting protein pellet was resuspended in ca. 10 mL TE. Sodium dodecyl sulfate-polyacrylamide gel electrophoresis (SDS-PAGE) was then performed to determine if the recombinant Grx was soluble or contained in the insoluble fraction.

When the protein aggregated into inclusion bodies, additional steps were included in order to solubilize the Grx. The insoluble material (contained in the 0–40% ammonium sulfate fraction) was first washed four times with 1 M urea and 10 mM EDTA and then two times with sterile water. The pellet was then treated with 8

TABLE 1  
Nucleotide Sequence of the Primers

Direct primers		Reverse primers	
a	5' TCTTCCATGGCGACGAGGATAAGATT 3'	d	5' GGGGATCCCTAAAAGTTAGCAAGTTCTCC 3'
a'	5' AAAACCATGGCTACCAGGATTAGATTGCCATCA 3'	d'	5' AAAAGGATCCTCATTAAAAGTTAGCAAGTTCT 3'
b	5' GGGCCATGGCTGGCAGCCCTGAAGCT 3'	e	5' GGGGGATCCTTAAAAGTCATCTTTCTGCTC 3'
c	5' GGGCCATGGCGACGCTGAAGCTACT 3'	f	5' GGGGGATCCTCATTCTAGTTTAAAGTCATC3'
c'	5' AAAACCATGGGTAGCCCTGAAGCTACT 3'		

Note. *Nco*I and *Bam*HI restriction sites are underlined. Nucleotides optimized for the production in *E. Coli* are in bold characters. The following constructions have been obtained with the primer's combinations listed: pET-Grx1A, a and d; pET-Grx1B, b and d; pET-Grx1C, c and d; pET-Grx1A', a' and d'; pET-Grx1C', c' and d'; pET-Grx2, b and e; pET-Grx3, b and f.

M urea dissolved in TE containing 10 mM DTT for 30 min at 4°C and dialyzed twice against 3 L of TE to eliminate urea.

Soluble samples were subjected to two chromatographic steps, a gel filtration on a Sephadex G50 column (5 × 70 cm) (Amersham Pharmacia Biotech, Uppsala, Sweden), followed by a DEAE-Sephadex chromatography (2 × 20 cm) (Amersham Pharmacia Biotech, Uppsala, Sweden), both in the presence of TE buffer. On the G50 column, Grx-containing fractions were localized either by the 2-hydroxyethyl disulfide (HED) reduction test (see below) or by running SDS-PAGE on selected fractions. In some cases, the recombinant Grx sample was not separated from the proteins of high molecular weight. These samples were loaded again on Sephadex G50 after a treatment with 10 mM DTT and 200 mM NaCl to exclude respectively thiol or electrostatic interactions with other proteins. When needed, the fractions of interest were dialyzed against TE buffer to eliminate NaCl before the DEAE chromatography. Generally, Grx was not retained on the DEAE matrix and could be collected in the passed through fraction.

All proteins were finally concentrated and dialyzed against TE buffer by ultrafiltration in an Amicon cell (Amicon, Beverly, MA) equipped with a YM 10 membrane under a nitrogen pressure of 5 bars. The recombinant proteins were then aliquoted at concentrations of ca. 3–5 mg/mL and stored at –20°C.

#### *In Vitro* Glutaredoxin Activity

The HED reduction test was used essentially to localize poplar Grx during purification steps. The test was performed in 1 mL of 100 mM Tris-HCl, pH 8, 2 mM EDTA, 150 μM NADPH (Boehringer Mannheim, Germany), 1 mM glutathione (Sigma, St. Louis, MO), 1 unit glutathione reductase (Sigma), and 7 mM HED (Acros, Noisy-le-grand, France). The Grx extract was added after 2 min of incubation, allowing disulfide bridge formation between glutathione and HED. The oxidation of NADPH was measured at 340 nm.

The reduction of dehydroascorbate (DHA) (Sigma)

into ascorbate was also used to evaluate the functionality of the recombinant proteins. One milliliter of reaction mixture contains 50 mM phosphate buffer, pH 7, 2 mM EDTA, 150 μM NADPH, 500 μM reduced glutathione, 1 unit glutathione reductase, and 1 mM DHA. The recombinant Grx was added after 1 min of incubation at 30°C and the oxidation of NADPH followed spectrophotometrically at 340 nm.

#### SDS-PAGE, N-Terminus Sequencing, and Mass Spectrometry Determination

The level of protein expression in bacterial extracts, the presence of Grx in the G50 fractions, and the purity of the proteins were analyzed by SDS-PAGE (21). Three to 10 μg of protein dissociated in the presence of β-mercaptoethanol and not heated were analyzed on 14% polyacrylamide gels. Sequencing of ca. 100 pmol of the Grx purified was performed on the first 10 amino acids to determine the N-terminal sequence of the recombinant protein. Edman degradation was performed on a Beckman Instruments LF 3000 sequencer. Phenylthiohydantoin-amino acids were identified by chromatography on a micro-PTH ODS Spherogel column (2 × 150 mm) using the system Gold analytical microbore HPLC.

The molecular masses of the recombinant proteins were determined by matrix-assisted laser desorption ionization/time-of-flight mass spectrometry with a PE Biosystems/Voyager-DE STR instruments operating in a positive reflector mode. 2,5-dihydroxybenzoic acid was used as matrix.

## RESULTS

### Sequence Analysis

As glutaredoxin is not a very abundant enzyme and poplar xylem/phloem is also not a very good biochemical material to start with, it is impossible to isolate the protein directly from the plant and deduce its amino acid sequence. It is thus necessary to use molecular biology techniques to gain access to the recombinant

protein. A putative glutaredoxin sequence (Grx1) was reconstituted by overlapping two poplar ESTs with respective accession numbers AI166603 and AI162979 and cloned by PCR into the pET-3d plasmid. Overall, the cDNA coding sequence is 378 bp long, resulting in a protein of 125 amino acids, including the initiator methionine. The deduced amino acid sequence possesses the conserved active site YCPYC, characteristic of the glutaredoxins (Fig. 1). This figure also shows two alternative C-termini assuming that there is an error in the sequence of the EST, resulting in a frameshift (denominated later in this paper Grx2 and Grx3). The theoretical molecular weight, *pI*, and molar extinction coefficient of Grx1 have been determined by the program Prot param tool from Exspasy (<http://www.expasy.org/tools/protparam.html>) and are respectively 13,649 Da, 6.1, and 9650 M cm<sup>-1</sup> at 280 nm. An interesting feature of this sequence is that when compared to most available plant Grx sequences, it displays an N-terminus extension of ca. 25 amino acids. The interrogation of the PSORT prediction site (<http://psort.nibb.ac.jp/form.html>) suggests that the protein could have a N-terminus transit peptide targeting for excretion outside the cell. The cleavage site is predicted to be between alanine 27 and 28.

As a consequence, we have decided to clone different constructions into pET-3d, a long sequence named pET-Grx1A (MATRIRL) and two truncated sequences without the putative transit peptide called respectively pET-Grx1B (MAGSPEATFVKK) and pET-Grx1C (MGSPEATFVKK) (Fig. 1). In brackets is indicated the N-terminus sequence resulting from these constructions. The details of the sequences and combination of the cloning oligonucleotides are given in Table 1. The sequences in the pET-Grx1B and pET-Grx1C constructions programmed respectively for proteins of 99 and 98 amino acids. The theoretical molecular weights, *pI*, and molar extinction coefficient of Grx1B and 1C are respectively 10,957 or 10,886 Da, 6.1, and 3960 M cm<sup>-1</sup> at 280 nm. The rationale behind this choice is the following: it is clear from the literature that the precursor sequences when overexpressed in *E. coli* are either cleaved at a site close to the putative cleavage site or very frequently unstable and degraded (22, 23). On the other hand, when the signal peptide is eliminated, in general the protein is expressed with a high yield in a soluble form. In our case, whatever the construction used, no glutaredoxin overexpression was observed in *E. coli* strain BL21(DE3) either using SDS-PAGE or when testing in the HED reduction (data not shown).

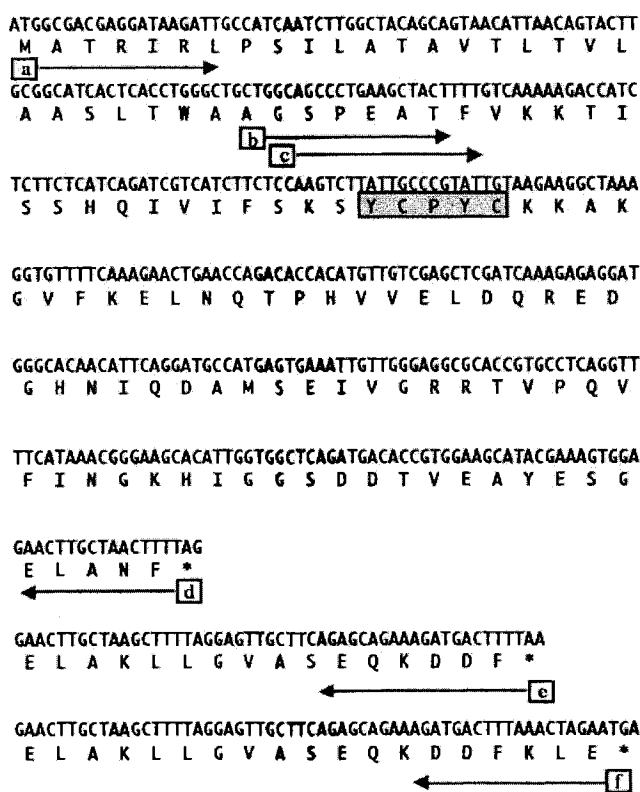

FIG. 1. Nucleotide and deduced amino acid sequences of poplar glutaredoxin. The three alternate C-termini of Grx1, 2, and 3 are indicated as well as the position of the primers used for PCR cloning. The active site is shade boxed.

Cotransformation with pSBET

One possibility to explain this absence of production is the existence of rare codons in the sequence that are not adapted to the *E. coli* translation machinery. In particular, the AGG and AGA codons triplets for arginine are very poorly used in *E. coli* and could prevent protein expression. These codons are even more unfavorable when they are located in the 5' end of the cDNA sequence or when they are repeated in tandem (24). Two such unfavorable arginine codons are located in the six first codons of the Grx1 sequence, and additionally there is a tandem of Arg codons in positions 94 and 95, the first one being unfavorable. To overcome this problem, the strain BL21(DE3) was cotransformed with plasmid pSBET which encodes the tRNA recognizing the AGG and AGA codons (20) and protein expression was analyzed as above.

When the cells containing either pET-Grx1A or pET-Grx1C were cotransformed with pSBET, no expression was observed. This strategy was however clearly successful with the construction pET-Grx1B. The recombinant protein was generally soluble but the solubility seemed to depend on the growth temperature, and on the timing and length of the induction period. As these parameters are difficult to manipulate all together, it was not always possible to obtain a soluble recombinant protein. Moreover, N-terminal sequencing indicates a N-terminus clipping with a partial excision of the N-terminal methionine and degradation up to three or

four first amino acids. It is difficult to explain why among the two shorter constructions, only pET-Grx1B is a productive one. Interestingly, the only difference between constructions pET-Grx1B and pET-Grx1C is an additional alanine behind the initiator methionine in N-terminal for pET-Grx1B. One level of explanation for the large fluctuations observed in expression between these three constructions is related to the nucleotide composition of the 5' and 3' ends as explained below.

#### *Introduction of Silent Mutations at the 3' and the 5' End Nucleotide Sequence*

Studies about the preferentially used stop codon demonstrate that in *E. coli* the UAA stop codon is more efficient than the two others (UAG and UGA) as translation terminator and even more when present in the UAAU sequence (25). A new reverse oligonucleotide that contains the two stop codons TAA and TGA in tandem (named oligo d' in Table 1) was thus synthesized. In addition, Bucheler *et al.* have demonstrated the importance of the third base of the codon in the first eight codons for a correct initiation of the translation step and as a consequence for the protein expression in *E. coli* (26). More specifically, it appears that the presence of A or T in this position favors, at least in some cases, a better expression of the recombinant protein. It has also been shown that the nature of the codon adjacent to the initial start codon is very important for the translation of the sequence because of its intervention in the ribosomal-binding site structure (27). To take into account these biases, two new forward oligonucleotides were constructed (named a' and c' in Table 1). In primer a', the second codon GCG was replaced by GCT, the third ACC by ACC, and the fifth ATA by ATT (in addition to the above mentioned rule, ATA is a very poor codon in *E. coli*). In oligo c', the second codon GGC is replaced by GGT. In relation with this modification, Looman *et al.* have described that the GGC codon is never used in second position whereas GGT is (27). Combining the use of primers a' and d' and of primers c' and d' resulted in two new constructions pET-Grx-1A' and pET-Grx-1C'.

Cotransformation of the strain BL21(DE3) by pSBET together with these new constructions leads to protein overexpression only for pET-Grx-1C' and further analysis showed that the corresponding recombinant protein was insoluble. Different treatments, described under Materials and Methods, allow us to solubilize and partially purify the recombinant Grx. N-terminus sequencing confirms the sequence MGSPEATFVKK of the protein and indicates that the N-terminal methionine is partially cleaved (ca. 75%). The presence of glycine which has a very small side chain as the adjacent residue generally favors the cleavage of the methionine

(28). Clearly, the optimization of the coding sequence helped solve the expression problem in the case of pET-Grx1C', but did not improve the solubility problem.

#### *Modifications of the 3' Nucleotide Sequence Leading to Alternate C-Terminal Amino Acid Sequences*

The recent availability in the GenBank database of a glutaredoxin nucleotide sequence from *Arabidopsis thaliana* (Accession No. AJ271472), strongly homologous to the poplar sequence (ca. 75% identity), prompted us to reexamine the 3' end sequence. It is clear that ESTs are generally not completely secure in terms of nucleotide sequence and this led us to modify the 3' end sequence, taking into account deduced amino acid comparisons (data not shown). As a consequence, two reverse primers, e and f, were constructed and used to amplify from the cDNA library two alternate versions of poplar Grx that end with sequences YESGELAKLLGVASEQKDDF and YESGELAKLLGVASEQKDDFKLE instead of YESGELANF (see Fig. 1). Two new recombinant plasmids were engineered, leading to constructions pET-Grx2 (primers b and e) and pET-Grx3 (primers b and f) (cf. Table 1). The proteins encoded by these constructions were shortened on the N-terminus side, but elongated on the C-terminus side with respectively 110 and 113 amino acids. The theoretical molecular masses,  $pI$ , and molar extinction coefficient of Grx2 and 3 are respectively 12,156 or 12,526 Da, 5.8, and 3960 M cm<sup>-1</sup> at 280 nm.

Constructions pET-Grx2 and pET-Grx3 led to the overexpression of Grx in a soluble form. As a consequence the protein could be purified relatively easily using a combination of ammonium sulfate fractionation, Sephadex G50 gel filtration and DEAE chromatography as described under Materials and Methods. An example of the elution profile of the Sephadex G50 step is shown in Fig. 2. Because of the absence of Trp residues in the sequence, the UV absorption of the protein is quite low and no additional peak or shoulder peak is detected on the chromatogram (Fig. 2A). On the other hand, SDS-PAGE of selected fractions clearly shows the distribution of the recombinant protein through the various fractions and the separation of the bulk of the protein from high-molecular-weight contaminants (Fig. 2B). Up to 9.5 mg of pure recombinant protein could be obtained per liter of culture. The molecular masses of Grx2 and Grx3 were analyzed by mass spectrometry and found to be 12,023 and 12,393 Da, respectively. Comparing these values to those of the theoretical masses obtained directly from the amino acid sequence (12,156 and 12,526 Da) indicates that both proteins are smaller by 133 Da, a value that would fit well with the removal of the N-terminus methionine. This was confirmed for Grx2 by analysis of the N-terminus sequence which was found to be AGSPEATFVK, indicating a complete excision of the methionine. In addition,

## EXPRESSION OF POPLAR GLUTAREDOXIN

239

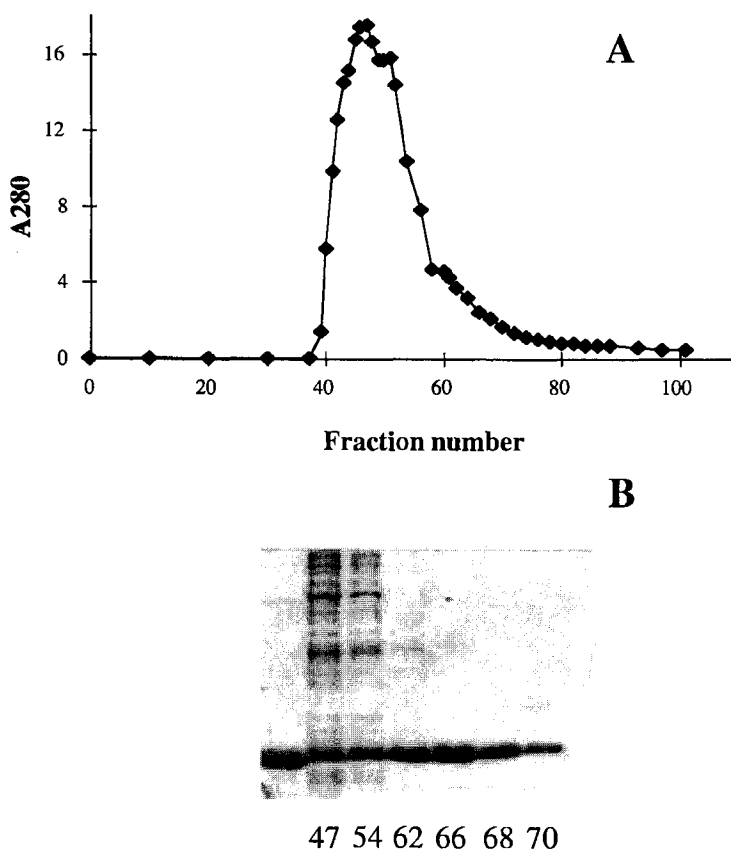

FIG. 2. (A) Elution profile of the Sephadex G50 column. (B) SDS-PAGE 14%. Lane 1, purified sample of Grx1B.

the masses of the recombinant products confirm the sequences of Grx2 and Grx3 and indicate that there is no proteolytic cleavage at the C-terminus of both proteins. Figure 3 shows the electrophoretic pattern of all the protein preparations: it clearly indicates that the preparations of highest purity are those corresponding to constructions pET-Grx2 and pET-Grx3 where the recombinant protein is produced in a soluble form. A peculiar feature is that all preparations exhibit an apparent molecular mass of ca. 15 kDa, despite having

real masses closer to 12 kDa. Such atypical electrophoretic or chromatographic behaviors have already been observed for other proteins such as ferredoxin for example (29).

Table 2 summarizes the yield of recombinant proteins obtained with each construction and the specific activities of every purified protein with the two substrates HED and DHA. The yields varied between 6 mg/L (Grx1B and Grx3) and 14 mg/L (Grx 1C'). All preparations exhibited activity with HED, an artificial substrate of Grx which contains a disulfide bridge, but

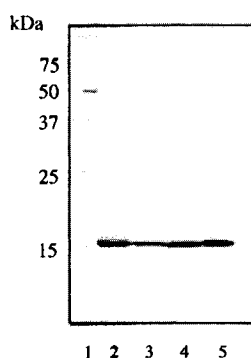

FIG. 3. SDS-PAGE showing the four recombinant proteins. Lane 1, molecular weight markers; lane 2, Grx1C'; lane 3, Grx1B; lane 4, Grx2; lane 5, Grx3. Acrylamide concentration 14%.

TABLE 2

Yield and Specific Activity of the Different Recombinant Grx Preparations

	Yield (mg/liter)	HED activity	DHA activity
Grx1C'	14	$0.81 \pm 0.04$	1 d
Grx1B	6	$1.17 \pm 0.01$	1 d
Grx2	10	$55 \pm 1$	$50.5 \pm 1$
Grx3	6	$49 \pm 3$	$49 \pm 0.5$

*Note.* The yield is expressed in milligrams of pure recombinant protein per liter of bacterial culture. Specific activities are the result of three independent assays. It is expressed in nanomoles NADPH oxidized per minute and per microgram of protein. Basal activities without Grx were withdrawn. 1 d, limit of detection.



Grx2 and Grx3 were much more efficient catalysts than Grx1B and 1C'. Alternatively, when dehydroascorbate was used as a substrate, only Grx2 and Grx3 were active with similar efficiencies, and both Grx1B and Grx1C' were inactive, even at higher concentrations.

## DISCUSSION

The initial lack of expression for recombinant glutaredoxin in *E. coli* has been overcome by successively shortening the 5' nucleotide sequence, cotransforming with a plasmid rescuing the Arg unfavorable codons, optimizing the 5' and 3' ends of the cDNAs and finally elongating the 3' end which resulted in a soluble protein, shorter on the N-terminus side and elongated on the C-terminus side compared to the first versions tested. Because of the relative variations observed in the sequence length of several glutaredoxins, it is not always easy to predict where a given protein should start and end, more especially so because the N and C-terminal ends are generally the most variable regions in proteins. Structurally, it has been observed that the shortest forms of glutaredoxin (*E. coli* or T<sub>4</sub>) lack an  $\alpha$ -helix on the N-terminus (30). In this respect, even though they have been shortened on the N-terminus side, the constructions Grx1B, Grx1C, Grx2, and Grx3 are all longer than the short glutaredoxins and are predicted to possess this additional N-terminus helix. Overall, all constructions which contain the N-terminus extension that presumably leads to excretion were unsuccessful.

The situation is a bit more complex on the C-terminus side, because of low similarity to the existing structural models. It appears nevertheless that the C-terminus end of constructions Grx1B or Grx1C is likely part of a C-terminus  $\alpha$ -helix that may have been shortened. Because of the low homologies in the C-terminus region, structure predictions do not allow to predict whether the C-terminal ends of constructions Grx2 and Grx3 are indeed involved in a longer  $\alpha$ -helix or in another structural unit. Nevertheless, it appears likely that the solubility problems encountered in the beginning of this study are the result of a truncation of the protein on the C-terminus side which results in increased hydrophobicity and partial insolubilization of the polypeptide.

All biochemical evidence supports the proposal that the longest C-terminus forms may represent a better and more stable version of plant Grx. All versions of poplar Grx constructed in this study were active with HED, although the two C-terminus elongated forms were ca. 50-fold more active. In addition, only the two elongated forms were found to be able to reduce DHA. There is indeed some controversy in the literature concerning the reduction of DHA by plant glutaredoxin. A report by Szederkenyi *et al.* shows that the *Ricinus*

*communis* glutaredoxin is active in that reaction (17). However Minakuchi *et al.* and Morell *et al.* did not detect any activity for seed rice and spinach leaf glutaredoxins, respectively (18, 19). Our results clearly support the first observation.

As poplar Grx is now obtained in a very good purity, in a soluble form and with a good yield, this opens the way to structural and biochemical studies, including the preparation of variants by site-directed mutagenesis that will help identify the targets of this protein.

## ACKNOWLEDGMENTS

The authors thank Dr. Ricart for molecular mass determinations, Arnaud Javelle for helpful tips for cloning, and Sibel Catakli and Denis Tagu for critical reading and helpful suggestions.

## REFERENCES

- Halliwell, B., and Gutteridge, J. M. (1990) Role of free radicals and catalytic metal ions in human disease: An overview. *Methods Enzymol.* 186, 1–85.
- Holmgren, A. (1989) Thioredoxin and glutaredoxin systems. *J. Biol. Chem.* 264, 13963–13966.
- Kim, H. T., Russell, R. L., Raina, A. K., Harris, P. L., Siedlak, S. L., Zhu, X., Petersen, R. B., Shimohama, S., Smith, M. A., and Perry, G. (2000) Protein disulfide isomerase in Alzheimer disease. *Antioxid Redox Signal.* 2, 485–489.
- Laughner, B. J., Sehnke, P. C., and Ferl, R. J. (1998) A novel nuclear member of the thioredoxin superfamily. *Plant Physiol.* 118, 987–996.
- Vlami-Gardikas, A., Aslund, F., Spyrou, G., Bergman, T., and Holmgren, A. (1997) Cloning, overexpression, and characterization of glutaredoxin 2, an atypical glutaredoxin from *Escherichia coli*. *J. Biol. Chem.* 272, 11236–11243.
- Holmgren, A., and Aslund, F. (1995) Glutaredoxin. *Methods Enzymol.* 252, 283–292.
- Holmgren, A. (1979) Glutathione-dependent synthesis of deoxyribonucleotides: Characterization of the enzymatic mechanism of *Escherichia coli* glutaredoxin. *J. Biol. Chem.* 254, 3672–3678.
- Lillig, C. H., Prior, A., Schwenn, J. D., Aslund, F., Ritz, D., Vlami-Gardikas, A., and Holmgren, A. (1999) New thioredoxins and glutaredoxins as electron donors of 3'-phosphoadenylylsulfate reductase. *J. Biol. Chem.* 274, 7695–7698.
- Liu, J., and Rosen, B. P. (1997) Ligand interactions of the ArsC arsenate reductase. *J. Biol. Chem.* 272, 21084–21089.
- Wells, W. W., Xu, D. P., Yang, Y. F., and Rocque, P. A. (1990) Mammalian thioltransferase (glutaredoxin) and protein disulfide isomerase have dehydroascorbate reductase activity. *J. Biol. Chem.* 265, 15361–15364.
- Aslund, F., and Beckwith, J. (1999) Bridge over troubled waters: Sensing stress by disulfide bond formation. *Cell* 96, 751–753.
- Demple, B. (1998) A bridge to control. *Science* 279, 1655–1656.
- Nakamura, T., Ohno, T., Hirota, K., Nishiyama, A., Nakamura, H., Wada, H., and Yodoi, J. (1999) Mouse glutaredoxin—cDNA cloning, high level expression in *E. coli* and its possible implication in redox regulation of the DNA binding activity in transcription factor PEBP2. *Free Rad. Res.* 31, 357–365.
- Bandyopadhyay, S., Starke, D. W., Mielay, J. J., and Gronostajski, R. M. (1998) Thioltransferase (glutaredoxin) reactivates the

- DNA-binding activity of oxidation-inactivated nuclear factor I. *J. Biol. Chem.* 273, 392–397.
15. Barrett, W. C., DeGnore, J. P., Konig, S., Fales, H. M., Keng, Y. F., Zhang, Z. Y., Yim, M. B., and Chock, P. B. (1999) Regulation of PTP1B via glutathionylation of the active site cysteine 215. *Biochemistry* 38, 6699–6705.
  16. Davis, D. A., Newcomb, F. M., Starke, D. W., Ott, D. E., Miley, J. J., and Yarchoan, R. (1997) Thioltransferase (glutaredoxin) is detected within HIV-1 and can regulate the activity of glutathionylated HIV-1 protease *in vitro*. *J. Biol. Chem.* 272, 25935–25940.
  17. Szederkenyi, J., Komor, E., and Schobert, C. (1997) Cloning of the cDNA for glutaredoxin, an abundant sieve-tube exudate protein from *Ricinus communis* L., and characterisation of the glutathione-dependent thiol-reduction system in sieve tubes. *Planta* 202, 349–356.
  18. Morell, S., Follmann, H., and Haberlein, I. (1995) Identification and localization of the first glutaredoxin in leaves of a higher plant. *FEBS Lett.* 369, 149–152.
  19. Minakuchi, K., Yabushita, T., Masumura, T., Ichihara, K., and Tanaka, K. (1994) Cloning and sequence analysis of a cDNA encoding rice glutaredoxin. *FEBS Lett.* 337, 157–160.
  20. Schenk, P. M., Baumann, S., Mattes, R., and Steinbiss, H. H. (1995) Improved high-level expression system for eukaryotic genes in *Escherichia coli* using T7 RNA polymerase and rare Arg tRNAs. *Biotechniques* 19, 196–200.
  21. Laemmli, U. K. (1970) Cleavage of structural proteins during the assembly of the head of bacteriophage T4. *Nature* 227, 680–685.
  22. Jacquot, J. P., Keryer, E., Issakidis, E., Decottignies, P., Miginiac-Malow, M., Schmitter, J. M., and Créatin, C. (1991) Properties of recombinant NADP-Malate dehydrogenases from *Sorghum vulgare* leaves expressed in *Escherichia coli* cells. *Eur. J. Biochem.* 199, 47–51.
  23. Hodges, M., Miginiac-Malow, M., Decottignies, P., Jacquot, J. P., Stein, M., Lepiniec, L., Créatin, C., and Gadal, P. (1994) Purification and characterization of pea thioredoxin *f* expressed in *Escherichia coli*. *Plant Mol. Biol.* 26, 225–234.
  24. Makrides, S. C. (1996) Strategies for achieving high-level expression of genes in *Escherichia coli*. *Microbiol. Rev.* 60, 512–538.
  25. Poole, E. S., Brown, C. M., and Tate, W. P. (1995) The identity of the base following the stop codon determines the efficiency of *in vivo* translational termination in *Escherichia coli*. *EMBO J.* 14, 151–158.
  26. Bucheler, U. S., Werner, D., and Schirmer, R. H. (1990) Random silent mutagenesis in the initial triplets of the coding region: a technique for adapting human glutathione reductase-encoding cDNA to expression in *Escherichia coli*. *Gene* 96, 271–276.
  27. Looman, A. C., Bodlaender, J., Comstock, L. J., Eaton, D., Jhurani, P., De Boer, H. A., and Van Knippenberg, P. H. (1987) Influence of the codon following the AUG initiation codon on the expression of a modified lacZ gene in *Escherichia coli*. *EMBO J.* 6, 2489–2492.
  28. Hirel, P. H., Schmitter, M. J., Dessen, P., Fayat, G., and Blanquet, S. (1989) Extent of N-terminal methionine excision from *Escherichia coli* proteins is governed by the side-chain length of the penultimate amino acid. *Proc. Natl. Acad. Sci. USA* 86, 8247–8251.
  29. Schmitter, J. M., Jacquot, J. P., de Lamotte-Guéry, F., Beauvallet, C., Dutka, S., Gadal, P., and Decottignies, P. (1988) Purification, properties and complete amino acid sequence of ferredoxin from a green alga, *Chlamydomonas reinhardtii*. *Eur. J. Biochem.* 172, 405–412.
  30. Nordstrand, K., Aslund, F., Holmgren, A., Otting, G., and Berndt, K. D. (1999) NMR structure of *Escherichia coli* glutaredoxin 3-glutathione mixed disulfide complex: Implications for the enzymatic mechanism. *J. Mol. Biol.* 286, 541–552.

Article numéro 8 :

**Rouhier N, Gelhaye E, Jacquot JP. (2002)**

*Exploring the active site of plant glutaredoxin by site-directed mutagenesis.*

**FEBS Lett. 511(1-3):145-9.**

Le travail effectué dans cet article décrit la mutation de tous les acides aminés du site actif de cette Grx de peuplier, d'une part pour connaître l'importance de chaque résidu dans la catalyse et d'autre part pour transformer le site actif de cette Grx ( $_{26}YCPYC_{30}$ ) en celui d'une Trx (WCPPC). Six mutations ont été introduites aboutissant aux sites actifs modifiés ACPYC, YSPYC, YCPFC, YCPPC, YCPYS et WCPPC. Toutes ces protéines ont été exprimées chez *E. coli*, purifiées et leur activité a été évaluée. Les résultats obtenus indiquent que la cystéine 27 est indispensable à la catalyse, au contraire de la cystéine 30 démontrant que cette Grx peut fonctionner selon un mode de catalyse monothiol. La mutation de la tyrosine 26 en alanine réduit faiblement l'activité de la protéine pour chacun des tests enzymatiques utilisés suggérant que ce résidu n'est pas essentiel à l'activité de la protéine. La mutation de la tyrosine 29 en un autre acide aminé aromatique, la phénylalanine ne modifie pas l'activité de la protéine, alors que la mutation en proline abolit complètement ou presque son activité. Enfin, le mutant WCPPC présentant un site actif de Trx n'est plus actif quel que soit le test d'activité utilisé suggérant que le déterminisme structural de reconnaissance des Trx envers ses protéines cibles n'est pas uniquement contenu dans le site actif.

## Exploring the active site of plant glutaredoxin by site-directed mutagenesis

Nicolas Rouhier, Eric Gelhaye, Jean-Pierre Jacquot\*

Unité Mixte de Recherches INRA, Université Henri-Poincaré, UMR IaM 1136, Faculté des Sciences, P.O. Box 239, 54506 Vandœuvre Cedex, France

Received 7 November 2001; revised 13 December 2001; accepted 13 December 2001

First published online 28 December 2001

Edited by Hans Eklund

**Abstract** Six mutants (Y26A, C27S, Y29F, Y29P, C30S and Y26W/Y29P) have been engineered in order to explore the active site of poplar glutaredoxin (Grx) (Y<sub>26</sub>CPYC<sub>30</sub>). The cysteine mutants indicate that Cys 27 is the primary nucleophile. Phe is a good substitute for Tyr 29, but the Y29P mutant was inactive. The Y26A mutation caused a moderate loss of activity. The YCPPC and WCPPC mutations did not improve the reactivity of Grx with the chloroplastic NADP-malate dehydrogenase, a well known target of thioredoxins (Trxs). The results are discussed in relation with the known biochemical properties of Grx and Trx. © 2002 Federation of European Biochemical Societies. Published by Elsevier Science B.V. All rights reserved.

**Key words:** Glutaredoxin; Thioredoxin; Redox regulation; Dithiol/disulfide exchange

### 1. Introduction

Thioredoxin (Trx) and glutaredoxin (Grx) are structurally related proteins, the major function of which is to reduce disulfide bridges on other proteins. Both proteins differ by their mode of reduction and their active site sequence (YCP[Y/F]C for Grx and WC[G/P]PC for Trx) [1].

Trxs are fairly well characterized in plants, and it has been shown that there are multiple nuclear genes (close to 20 in the simple model *Arabidopsis thaliana* that encode cytosolic, mitochondrial and chloroplastic isoforms) [2]. In the cytosol and probably mitochondria, Trxs are reduced via NADPH and a flavoprotein, NADPH Trx reductase. Chloroplastic Trxs are reduced in the light by a cascade that involves the photosystem I, [2Fe2S] stromal ferredoxin and an iron-sulfur enzyme, ferredoxin-Trx reductase [3]. The targets of chloroplastic Trxs are well characterized, notably the redox-regulated fructose-1,6-bisphosphatase and NADP-malate dehydrogenase (MDH) [4,5]. Besides the two catalytic cysteines, the active site of Trx involves the conserved tryptophan residue adjacent to the most N-terminal cysteine and a buried aspartate residue that is conserved in all Trx sequences from bacteria to mammalian systems [6–8]. The redox potentials of Trxs are close to –300

mV, a value that makes them very efficient reductants of disulfide bridges [9]. The three-dimensional structure of Trxs is also very well described, all isoforms have a similar fold with a central pleated  $\beta$  sheet surrounded by  $\alpha$  helices. The attacking cysteine as well as the active site tryptophan are surface-exposed while the other cysteine is more buried [10].

Grxs are rather well known in bacteria (such as *Escherichia coli*), yeast and mammalian systems. In *E. coli* there are three Grx genes, at least five in yeast and apparently only two in human [11–14]. In all known organisms, Grxs are reduced via a cascade that involves NADPH, glutathione reductase (GR) and the tripeptide glutathione [1]. The redox potential of Grx is estimated to be around –230 mV [15]. Although the targets of Grx are not as well characterized as those of Trx, it is quite clear that Grx is the preferred donor to ribonucleotide reductase and as efficient as Trx with PAPS reductase [16,17]. On the other hand, the information about plant Grxs is more scarce. The questioning of GenBank indicates that there are also multiple genes in plants with rather large variations at the active site (from the canonic YCPYC to the less frequent YCPFC, but also to more exotic forms as GCCMS where the active site sequence is hardly recognizable). Plant Grxs have been purified from several sources (rice and spinach mostly) [18,19]. The protein was found to possess activity in the 2-hydroxyethyl disulfide (HED) reduction assay and also in the more physiological dehydroascorbate (DHA) reduction [18]. Quite recently, Grx has been cloned and overproduced from poplar [20]. It has been shown to be very effective in the DHA reduction, but also to be a good electron donor to a new cytosolic peroxiredoxin (Prx) [21]. Quite interestingly, Trx, Grx and Prx have been found in sieve tubes and the phloem sap, sometimes in very large amounts, a property that suggests a role in the long distance transmission of the redox signal in plants [21–23]. One interesting feature of the poplar Grx is that it is elongated both on the N- and C-termini compared to the mammalian or bacterial Grxs characterized so far. It is thus of interest to investigate the biochemical reactivity of this type of protein in order to compare those data with the ones obtained with shorter versions of this protein in distant organisms. We describe in this paper a series of mutations that help understand the importance of the amino acids of the active site.

\*Corresponding author.

E-mail address: j2p@scbiol.uhp-nancy.fr (J.-P. Jacquot).

**Abbreviations:** DHA, dehydroascorbate; DTT, dithiothreitol; Grx, glutaredoxin; GR, glutathione reductase; HED, 2-hydroxyethyl disulfide; NADP-MDH, NADP-malate dehydrogenase; Prx, peroxiredoxin; Trx, thioredoxin

### 2. Materials and methods

#### 2.1. Materials

Purified oligonucleotides, restriction enzymes, DNA polymerase and ligase were either from Eurogentec or from Invitrogen. IPTG,

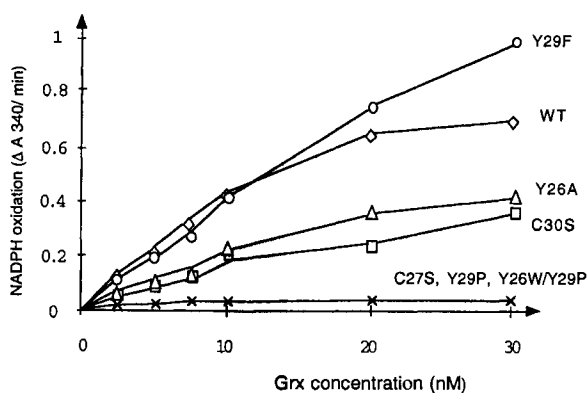

Fig. 1. Reduction of HED by WT and mutated poplar Grxs. All activities were measured at 30°C. After 1 min incubation of the system, the reaction was initiated by addition of Grx.

NADPH, HED, DHA, reduced glutathione (GSH) and GR were from Eurogentec, Boehringer, and Sigma. Chromatographic matrices were from Pharmacia. Kinetic measurements were followed using a Cary 50 spectrophotometer.

#### 2.2. Plasmids and strains

The plasmid used for cloning and expression was pET-3d which carries the resistance for ampicillin. When needed, an additional plasmid (pSBET, carrying a kanamycin resistance) [24] was used to co-transform the expression strain *E. coli* BL21(DE3). The cloning strain was *E. coli* DH5 $\alpha$ .

#### 2.3. Mutagenesis

Mutagenesis of the cloned cDNAs was effected by PCR. A strategy similar to the one in [25] was employed, generating two overlapping mutated fragments and in a second PCR reaction the full length mutated sequence. The two 'cloning' oligonucleotides had the following sequences (*Nco*I and *Bam*HI restriction sites underlined): forward 5'-GGGCCATGGCTGGCAGCCCTGAAGCT-3'; reverse 5'-GGGGGATCCTCATTCTAGTTAAAGTCATC-3'.

The mutagenic oligonucleotides had the following sequences (mutagenic bases in bold): Y<sub>26</sub>A FOR 5'-ATCTTCTCCAAGTCTGCT-TGCCCGTATTGT-3'; Y<sub>26</sub>A REV 5'-ACAATACGGCAAGCA-GACTTGGAGAAGAT-3'; Y<sub>26</sub>W-Y<sub>29</sub>P FOR 5'-TCCAAGTCT-TGGTCCCGCCTTGT-3'; Y<sub>26</sub>W-Y<sub>29</sub>P REV 5'-ACAAGCGGG-CACCAAGACTTGA-3'; C<sub>27</sub>S FOR 5'-TTCTCCAAGTCTTA-TAGCCCGTATTGTAAGAAG-3'; C<sub>27</sub>S REV 5'-CTTCTACAA-TACGGGCTATAAGACTTGGAGAA-3'; Y<sub>29</sub>P FOR 5'-TCTTA-TTGGCCCGCCTTGTAAAGAGGCT-3'; Y<sub>29</sub>P REV 5'-AGCCTC-TTACAAGCGGGCAATAAGA-3'; Y<sub>29</sub>F FOR 5'-TATTGCC-CGTTTTGTAAGAGG-3'; Y<sub>29</sub>F REV 5'-CCTCTTACAAAACG-GGCAATA-3'; C<sub>30</sub>S FOR 5'-TATTGCCCGTATTCTAAGAAGG-CTAAA-3'; C<sub>30</sub>S REV 5'-TTTAGCCTTCTTAGAATACGGGCAATA-3'.

The template used was the construction pET-Grx3 [20]. After digestion with *Nco*I and *Bam*HI, the full length mutated fragments were cloned into pET-3d. The mutations were verified by DNA sequencing and the recombinant plasmids were used to transform the expression strain and then ampicillin and kanamycin resistant clones selected.

#### 2.4. Expression and purification of the recombinant proteins

The transformed *E. coli* cells were successively multiplied to a final volume of ca. 5 l at 37°C. 100  $\mu$ M IPTG was added in the exponential phase and the bacteria harvested by centrifugation for 15 min at 5000 $\times$ g. The cells were resuspended in a TE buffer (Tris-HCl 30 mM, pH 8.0, EDTA 1 mM) which also contained 14 mM  $\beta$ -mercaptoethanol for the cysteine mutants. All subsequent chromatographic steps were effected in the same buffer. The recombinant proteins were purified by ammonium sulfate fractionation (50–90%), Sephadex G50 gel filtration and DEAE Sephacel chromatography. The samples were then concentrated and dialyzed by ultrafiltration in an Amicon cell (Millipore) equipped with a YM 10 membrane under nitrogen pressure. The proteins were stored by aliquots, frozen at -20°C at con-

centrations of ca. 4 mg/ml. The yield was around 10 mg homogeneous protein per liter culture.

#### 2.5. Biochemical assays

The assays describing the reductions of HED and DHA were performed as described in [20]. The Prx and NADP-MDH assays were as in [21,26]. The preparations of recombinant Grx, Prx and NADP-MDH have been described in [20,21,26].

The Prx reaction was effected in 500  $\mu$ l cuvettes in the presence of 50 mM K-phosphate buffer, 150  $\mu$ M NADPH, 1 mM GSH, 0.5 U GR, and 2.5  $\mu$ M poplar Prx and Grx. The reaction was started by adding 100  $\mu$ M H<sub>2</sub>O<sub>2</sub> after 1 min of incubation at 30°C to permit the reduction of the system. Activity was measured by following the oxidation of NADPH at 340 nm.

The activation medium for NADP-MDH (30  $\mu$ l) had the following composition: 50 mM Tris-HCl pH 8.0, 5 mM dithiothreitol (DTT), 0.8  $\mu$ M recombinant sorghum NADP-MDH and 20  $\mu$ M Grx or Trx as indicated. After 20 min incubation at 20°C, an aliquot of 20  $\mu$ l was used to determine the activity at 30°C as described in [5].

The purity of the protein preparations was estimated by SDS-PAGE as described by Laemmli [27].

### 3. Results

#### 3.1. Efficiency of the mutated Grxs in the 'classical' HED and DHA reduction tests

Fig. 1 shows the reactivity of the various mutants in the reduction of the non-physiological substrate, HED. Replacing Tyr 29 by a Phe residue had little effect on the activity, the protein behaving essentially as the wild-type (WT) enzyme. On the other hand, introducing a non-aromatic amino acid instead of either of the Tyr of the active site depressed the Grx activity (Y<sub>26</sub>A had a catalytic efficiency half the WT and the replacement of Tyr 29 by Pro resulted in an inactive protein). The C<sub>30</sub>S mutant retained 30% of the activity, but the C<sub>27</sub>S protein was inactive.

Essentially similar results were obtained in the DHA reduction (Fig. 2). When Tyr 29 was replaced by Pro, the protein was inactive and the replacement of Cys 27 by a serine likewise produced an inactive catalyst. Replacing Tyr 26 by an Ala decreased the catalytic efficiency (ca. 20%). On the other hand, the Y<sub>29</sub>F and C<sub>30</sub>S mutations produced better catalysts. It is especially remarkable that the monocysteine mutant C<sub>30</sub>S which contains only Cys 27 is more efficient than the WT protein (the activity is nearly doubled at every concentration tested).

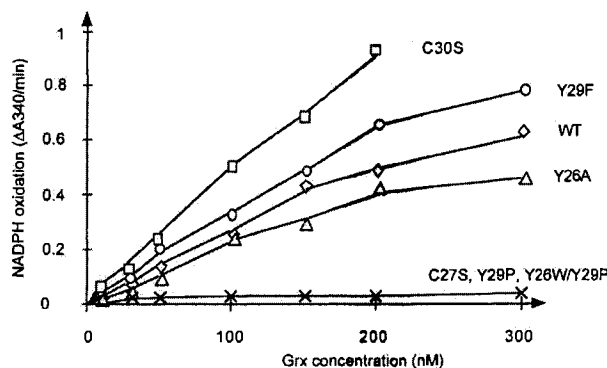

Fig. 2. Reduction of DHA by WT and mutated poplar Grxs. All activities were measured at 30°C. After 1 min incubation of the system, the reaction was initiated by addition of Grx.

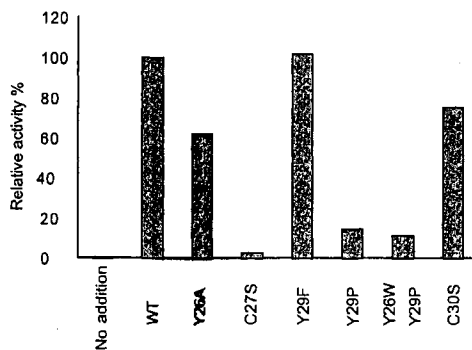

Fig. 3. Activity of Prx with WT and mutated Grxs. The activity is expressed in % of the WT protein. 100% activity is 0.55  $\Delta$ OD/min. Details of the reaction are given in Section 2.

### 3.2. Grx efficiency vs plant type C Prx

It has been demonstrated recently that type C Prx of plants uses both Trx and Grx as proton donors [21]. It was thus of interest to determine if the various mutants generated here are able to sustain the catalytic activity of Prx in this newly described reaction. Fig. 3 shows the results of those experiments. The WT and Y29F mutant show similar activity. On the other hand, replacing the two Tyr residues by non-aromatic side chains decreased the catalytic efficiency. Finally, the C30S mutant retains most of its catalytic efficiency and the C27S protein is inactive.

### 3.3. Activation of NADP-MDH by mutated Grxs

Two of the mutations that we have engineered in this work transform the Grx active site into a Trx-like active site (YCPPC and WCPPC). It was expected that these mutations should increase the reactivity of Grx vs the NADP-MDH, a well characterized target enzyme of Trx. Fig. 4 shows the reactivity of the various mutants with NADP-MDH. It is interesting that the WT Grx is able to activate the enzyme in the presence of DTT with reasonably good efficiency (nearly half the capacity of the non-physiological Trx *h* at the same concentration of 20  $\mu$ M). All mutants tested showed catalytic activity, but all mutations decreased the efficiency except for Y26A. The two mutations that were intended to mimic the Trx active site (Y29P and Y26W/Y29P) did not improve the reactivity at all. Interestingly, both the C27S and C30S mutants retained the capacity to activate the NADP-MDH but their efficiencies were strongly reduced (to ca. 25% of the WT).

## 4. Discussion

### 4.1. Mutations of the active site cysteines

In the Grx dependent reactions (HED and DHA reduction and Prx activation), the mutation of Cys 27 leads to a virtually inactive enzyme. On the other hand, the mutation of Cys 30 into Ser had either a strongly negative effect (HED), a mildly negative effect (Prx) or a positive effect (DHA). All these data strongly suggest that Cys 27 is the primary nucleophile of the reaction and that Cys 30 is the backup cysteine. Similar results have been obtained with the *E. coli* and human Grx or all Trxs where the catalytic cysteine is always located on the N-terminus side [28–30]. It seems thus that the N- and C-termini extensions of plant Grx do not alter that property.

Additionally, these site-directed mutagenesis experiments indicate that Grx can be quite efficient as a single cysteine catalyst, confirming that it can act in the so-called monothiol pathway [31]. Moreover, these experiments suggest that the numerous natural monocysteine versions of Grx that exist in the databanks are almost certainly functional catalysts.

### 4.2. Importance of the aromatic residues of the active site

The replacement of the Tyr residue present between the two catalytic cysteines by a proline leads to a drastic decline in reactivity. It is clearly essential to keep an aromatic residue in this position as the Y29F mutant is a very good catalyst in all Grx dependent reactions tested. This Tyr residue has been implicated as one of the ligands necessary for the fixation of glutathione to *E. coli* Grx3 or T<sub>4</sub> Grx [11,32]. On the other hand, it is not necessary to have an aromatic residue in position 26 (N-terminus to the catalytic cysteine) as the Y26A mutant kept at least half of the reactivity of the WT protein. This is very much in contrast with the case of Trx where the removal of the Trp adjacent to the catalytic cysteine has a very strong negative effect [6,33].

### 4.3. The NADP-MDH is activated by plant Grx and its mutants

The NADP-MDH has been recognized as a target of Trxs since a long time. The chloroplastic Trx *f* is the most efficient, followed by chloroplastic Trx *m*, and the cytosolic Trx *h* [34]. Mammalian Trxs are very poor reductants/activators of this enzyme [35]. All Trxs which have been demonstrated as capable of activating this enzyme have either a WCGPC or a WCPPC active site. By making the Y29P and Y26W/Y29P mutations, we have engineered proteins with active sites that have been transformed into YCPPC and WCPPC. It was thus expected that these mutations could result in Grxs with better reactivity vs the NADP-MDH. The results in Fig. 4 indicate clearly that this is not the case as only the Y26A mutant has an activity comparable to the WT protein and all other mutations decrease the reactivity. It is surprising to observe that WT Grx is able to induce the activation of the enzyme in the presence of DTT (see Fig. 4). This activation is dependent on the concentration of added Grx and on DTT (data not shown). The WT poplar Grx is not as efficient as the cytosolic Trx *h* but more efficient than the human Trx or the Trxs of *Dictyostelium discoideum* [35,36]. We have checked that this reactivity is not due to contaminating *E. coli* Trx in the recombinant Grx preparations. We have indeed quantitated the

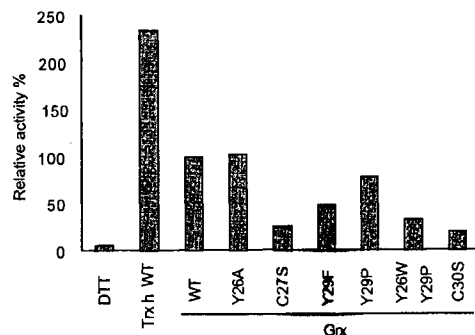

Fig. 4. Activity of NADP-MDH with WT and mutated Grxs. Activities are expressed in % of the WT Grx. 100% activity is 0.4 $\Delta$ OD/min. Experimental details are given in Section 2.

contamination of those preparations by the NTR/DTNB system and found that it could not exceed 0.3%. At a Grx concentration of 20  $\mu$ M in Fig. 4, the *E. coli* Trx concentration is thus lower than 60 nM, a value at which no detectable NADP-MDH activation occurs [37]. This activation of NADP-MDH by Grx is likely to be non-physiological since GSH could not replace DTT, even in the presence of NADPH and GR (data not shown). Three additional observations support the proposal that Grx is indeed not a physiological activator of NADP-MDH. First, it seems that there are no chloroplastic sequences for Grx in protein databases. Second, the redox potential of Grx (normally around  $-230$  mV) is not adequate with respect to the ones of the NADP-MDH disulfide bridges ( $-280$  and  $-300$  mV) for an efficient reaction to take place [38]. Third, the fact that the C30S mutant keeps a level of activity similar to the C27S mutant suggests that the role of Grx in this reaction is non-catalytic. We propose thus that Grx acts here in a non-catalytic way to modify the accessibility of the active site to DTT which has the right redox potential. Such a structural role has already been observed in the case of the interaction between the T<sub>7</sub> DNA polymerase and the *E. coli* Trx [39]. The results obtained with the C27S mutant seem to support such a hypothesis since Cys 30 is widely recognized as the non-catalytic one, a property also verified in the other reactions described here.

#### 4.4. Concluding remarks

Mutations similar to those described here have already been performed either on *E. coli* Trx to transform it into a Grx or a DsbA protein [40,41], or on DsbA to transform it into a Grx or a Trx [42]. In most of these mutants, essentially physico-chemical characteristics as  $pK_a$  values and redox potentials have been determined but few kinetic experiments have been performed except in [40] where the creation of a CGHC site has been shown to be accompanied by an increase in PDI-like activity. In this study, nearly all the mutants that we have generated are less active than the WT protein, in contrast to initial expectations. Transforming the Grx active site into a Trx-like active site did not improve the reactivity with NADP-MDH or Trx reductase (data not shown). Similarly to what is described here, simulations of Trx or Grx-like active sites in trypanothione 2 did not result in Trx or Grx-like activities [43]. Overall, these data strongly suggest that the structural determinants for Trx or Grx reactivity go beyond the sequence of the active site.

Nevertheless, the series of mutants generated here help to understand the functioning of plant Grxs. The catalytic cysteine as well as the importance of an aromatic residue inside the regulatory sequence and adjacent to the backup cysteine have been uncovered. An additional interesting finding of this study is the capacity of Grx to activate the NADP-MDH. This enzyme has always been reputed as promiscuous as it accepts many different Trxs as regulators, in contrast to fructose-1,6-biphosphatase that requires selectively Trx *f*. The data presented here indicate that the DTT NADP-MDH activation test should be used cautiously, as Grx is also active in this process despite the fact that it probably does not act in a catalytic way.

#### References

[1] Holmgren, A. (2000) *Antioxid. Redox Signal* 2, 811–820.

[2] Meyer, Y., Verdoucq, L. and Vignols, F. (1999) *Trends Plant Sci.* 4, 388–394.

[3] Schürmann, P. and Jacquot, J.P. (2000) *Annu. Rev. Plant Physiol. Plant Mol. Biol.* 51, 371–400.

[4] Chiadmi, M., Navaza, A., Miginiac-Maslow, M., Jacquot, J.P. and Cherfils, J. (1999) *EMBO J.* 18, 6809–6815.

[5] Miginiac-Maslow, M., Johansson, K., Ruelland, E., Issakidis-Bourguet, E., Schepens, I., Goyer, A., Lemaire-Chamley, M., Jacquot, J.P., Le Maréchal, P. and Decottignies, P. (2000) *Physiol. Plant.* 110, 322–329.

[6] Krause, G. and Holmgren, A. (1991) *J. Biol. Chem.* 266, 4056–4066.

[7] Dyson, H.J., Jeng, M.F., Tennant, L.L., Slaby, I., Lindell, M., Cui, D.S., Kuprin, S. and Holmgren, A. (1997) *Biochemistry* 36, 2622–2626.

[8] Menchise, V., Corbier, C., Didierjean, C., Saviano, M., Benedetti, E., Jacquot, J.P. and Aubry, A. (2001) *Biochem. J.* 359, 65–75.

[9] Hirasawa, M., Schürmann, P., Jacquot, J.P., Manieri, W., Jacquot, P., Keryer, E., Hartman, F. and Knaff, D.B. (1999) *Biochemistry* 38, 5200–5205.

[10] Jeng, M.F., Campbell, A.P., Begley, T., Holmgren, A., Case, D.A., Wright, P.E. and Dyson, H.J. (1994) *Structure* 2, 853–868.

[11] Nordstrand, K., Sandstrom, A., Aslund, F., Holmgren, A., Otting, G. and Berndt, K.D. (2000) *J. Mol. Biol.* 303, 423–432.

[12] Lundberg, M., Johansson, C., Chandra, J., Enoksson, M., Jacobsson, G., Ljung, J., Johansson, M. and Holmgren, A. (2001) *J. Biol. Chem.* 276, 26269–26275.

[13] Gladyshev, V.N., Liu, A., Novoselov, S.V., Krysan, K., Sun, Q.A., Kryukov, V.M., Kryukov, G.V. and Lou, M.F. (2001) *J. Biol. Chem.* 276, 30374–30380.

[14] Rodriguez-Manzanique, M.T., Ros, J., Cabisco, E., Sorribas, A. and Herrero, E. (1999) *Mol. Cell. Biol.* 19, 8180–8190.

[15] Aslund, F., Berndt, K.D. and Holmgren, A. (1997) *J. Biol. Chem.* 272, 30780–30786.

[16] Berardi, M.J. and Bushweller, J.H. (1999) *J. Mol. Biol.* 292, 151–161.

[17] Lillig, C.H., Prior, A., Schwenn, J.D., Aslund, F., Ritz, D., Vlamis-Gardikas, A. and Holmgren, A. (1999) *J. Biol. Chem.* 274, 7695–7698.

[18] Sha, S., Minakuchi, K., Higaki, N., Sato, K., Ohtsuki, K., Kurata, A., Yoshikawa, H., Kotaru, M., Masumura, T., Ichihara, K. and Tanaka, K. (1997) *J. Biochem.* 121, 842–848.

[19] Morell, S., Follmann, H. and Haberlein, I. (1995) *FEBS Lett.* 369, 149–152.

[20] Rouhier, N., Gelhaye, E., Sautiere, P.E. and Jacquot, J.P. (2002) *Prot. Expr. Purif.*, in press.

[21] Rouhier, N., Gelhaye, E., Sautiere, P.E., Brun, A., Laurent, P., Tagu, D., Gerard, J., de Fay, E., Meyer, Y. and Jacquot, J.P. (2001) *Plant Physiol.* 127, 1–11.

[22] Szederkenyi, J., Komor, E. and Schobert, C. (1997) *Planta* 202, 349–356.

[23] Ishiwatari, Y., Fujiwara, T., McFarland, K.C., Nemoto, K., Hayashi, H., Chino, M. and Lucas, W.J. (1998) *Planta* 205, 12–22.

[24] Schenk, P.M., Baumann, S., Mattes, R. and Steinbiss, H.H. (1995) *Biotechniques* 19, 196–200.

[25] Jacquot, J.P., Stein, M., Suzuki, A., Liottet, S., Sandoz, G. and Miginiac-Maslow, M. (1997) *FEBS Lett.* 400, 293–296.

[26] Ruelland, E., Johansson, K., Decottignies, P., Djukic, N. and Miginiac-Maslow, M. (1998) *J. Biol. Chem.* 273, 33482–33488.

[27] Laemmli, U.K. (1970) *Nature* 227, 680–685.

[28] Bushweller, J.H., Aslund, F., Wuthrich, K. and Holmgren, A. (1992) *Biochemistry* 31, 9288–9293.

[29] Foloppe, N., Sagemark, J., Nordstrand, K., Berndt, K.D. and Nilsson, L. (2001) *J. Mol. Biol.* 310, 449–470.

[30] Padilla, C.A., Spyrou, G. and Holmgren, A. (1996) *FEBS Lett.* 378, 69–73.

[31] Yang, Y., Jao, S., Nanduri, S., Starke, D.W., Mielal, J.J. and Qin, J. (1998) *Biochemistry* 37, 17145–17156.

[32] Nikkola, M., Gleason, F.K., Saarinen, M., Joelson, T., Bjornberg, O. and Eklund, H. (1991) *J. Biol. Chem.* 266, 16105–16112.

[33] Krimm, I., Lemaire, S., Ruelland, E., Miginiac-Maslow, M., Jacquot, J.P., Hirasawa, M., Knaff, D.B. and Lancelin, J.M. (1998) *Eur. J. Biochem.* 255, 185–195.

- [34] Aguilar, F., Brunner, B., Gardet-Salvi, L., Stutz, E. and Schürmann, P. (1992) *Plant Mol. Biol.* 20, 301–306.
- [35] Jacquot, J.P., de Lamotte-Guéry, F., Fontecave, M., Schürmann, P., Decottignies, P., Miginiac-Maslow, M. and Wollmann, E. (1990) *Biochem. Biophys. Res. Commun.* 173, 1375–1381.
- [36] Wetterauer, B., Véron, M., Miginiac-Maslow, M., Decottignies, P. and Jacquot, J.P. (1992) *Eur. J. Biochem.* 209, 643–649.
- [37] de Lamotte-Guery, F., Miginiac-Maslow, M., Decottignies, P., Stein, M., Minard, P. and Jacquot, J.P. (1991) *Eur. J. Biochem.* 196, 287–294.
- [38] Hirasawa, M., Ruelland, E., Schepens, I., Issakidis-Bourguet, E., Miginiac-Maslow, M. and Knaff, D.B. (2000) *Biochemistry* 39, 3344–3350.
- [39] Huber, H.E., Russel, M., Model, P. and Richardson, C.C. (1986) *J. Biol. Chem.* 261, 15006–15012.
- [40] Lundstrom, J., Krause, G. and Holmgren, A. (1992) *J. Biol. Chem.* 267, 9047–9052.
- [41] Mössner, E., Huber-Wunderlich, M. and Glockshuber, R. (1998) *Protein Sci.* 7, 1233–1244.
- [42] Huber-Wunderlich, M. and Glockshuber, R. (1998) *Fold. Des.* 3, 161–171.
- [43] Steinert, P., Plank-Schumacher, K., Montemartini, M., Hecht, H.J. and Flohe, L. (2000) *Biol. Chem.* 381, 211–219.



Article numéro 9 :

**Rouhier N, Vlamis-Gardikas A, Lillig CH, Berndt C, Schwenn JD, Holmgren A, Jacquot JP. (2003)**

*Characterization of the redox properties of poplar glutaredoxin.*

***Antioxid. Redox Signal. 5(1):15-22.***

Jusqu'à présent, la seule protéine cible connue des Grx de plantes est la Prx de type II (voir articles 11 et 12). Chez les bactéries notamment, un certain nombre de protéines cibles incluant la PAPS réductase ou la RNR sont connues. La Grx de peuplier est capable de servir de donneur d'électrons à ces deux enzymes d'*E. coli* suggérant qu'elle pourrait jouer un rôle analogue pour la RNR de plantes par exemple. Par contre, aucune séquence codant une PAPS réductase n'a été trouvée chez les plantes supérieures et l'équivalent fonctionnel de cette enzyme est une APS réductase, localisée dans les chloroplastes et qui possède un motif Grx en position C-terminale. Par ailleurs, cet article montre que cette Grx a une fonction au moins indirecte dans la réponse au stress oxydant en réduisant la Prx de type II mais qu'elle n'a pas la capacité de réduire directement les hydroperoxydes comme cela a été montré pour la Grx d'*Oryza sativa* et la Grx 1 de *S. cerevisiae*. Cette situation est d'autant plus surprenante qu'il existe chez *O. sativa* au moins trois isoformes de Prx de type II (n<sup>os</sup> d'accèsion Genbank AAG40130, BAA82377, BAA90363) et chez *S. cerevisiae* au moins 3 Gpx et 5 Prx capables de catalyser ces réactions (Carmel-Harel & Storz, 2000).

## Forum Original Research Communication

# Characterization of the Redox Properties of Poplar Glutaredoxin

NICOLAS ROUHIER,<sup>1</sup> ALEXIOS VLAMIS-GARDIKAS,<sup>2</sup> CHRISTOPHER HORST LILLIG,<sup>2</sup>  
CARSTEN BERNDT,<sup>3</sup> JENS-DIRK SCHWENN,<sup>3</sup> ARNE HOLMGREN,<sup>2</sup>  
and JEAN-PIERRE JACQUOT<sup>1</sup>

### ABSTRACT

The presence of glutaredoxins in plants is now well recognized, but their functions and natural substrates remain largely unknown. Recently, a poplar glutaredoxin has been biochemically characterized and several mutants have been engineered in order to explore its reactivity. This work focuses on some physiological functions of the enzyme. According to our findings, the poplar glutaredoxin can serve as an electron donor to the bacterial 3'-phosphoadenylylsulfate reductase as it supports both the catalysis by the enzyme *in vitro* and complements a methionine auxotroph strain of *Escherichia coli*. In addition, poplar glutaredoxin is able to reduce the *Escherichia coli* ribonucleotide reductase 1a (*in vitro* reduction of cytidine diphosphate). Although this glutaredoxin is described as an electron donor to a phloem-located peroxiredoxin, whose function is to detoxify hydroperoxides, we found that it does not directly reduce hydrogen peroxide or other alkyl hydroperoxides as described for yeast and rice glutaredoxins. However, the poplar glutaredoxin may be involved in the response to oxidative stress as its overexpression in *Escherichia coli* resulted in a higher resistance toward hydrogen peroxide, menadione, and *tert*-butyl hydroperoxide. *Antioxid. Redox Signal.* 5, 15–22.

### INTRODUCTION

THE THIOL REDOX STATUS OF THE CYTOSOL is maintained by the thioredoxin (Trx) and the glutathione/glutaredoxin (GSH/Grx) systems. Trx and Grx are small (~10–12 kDa), heat-stable disulfide oxidoreductases, with the conserved active site CXXC [typically CP(Y/F)C for Grx and WC(G/P)PC for Trx] (18, 19). These two proteins are constituted by a characteristic succession of  $\beta$  strands and  $\alpha$  helices, the  $\beta$  strands being organized into a central pleated  $\beta$  sheet surrounded by  $\alpha$  helices, the whole folding pattern known as the Trx/Grx fold. Initial reducing equivalents for both systems are provided by NADPH. In the Trx system, NADPH reduces Trx reductase, which then reduces Trx. Trx reductase is replaced by glutathione reductase and GSH in the Grx system. Grxs can re-

duce disulfides with a dithiol mechanism using both their active-site cysteine residues (33). An example is the reduction of the disulfide of the *Escherichia coli* ribonucleotide reductase 1a (*E. coli* RNR1a), which forms when the enzyme reduces ribonucleotides to deoxyribonucleotides under aerobic conditions (1). However, Grxs can utilize a monothiol mechanism for the reduction of mixed disulfides between proteins and GSH (protein-S-SG substrates) (26, 33).

Trx and Grx species can reduce both RNR and 3'-phosphoadenylylsulfate (PAPS) via PAPS reductase (23, 33, 43). Other substrates include a plasma glutathione reductase and a poplar type II peroxiredoxin (6, 36). Monothiol Grxs containing only one active-site cysteine are natural catalysts for the deglutathionylation of protein-S-SG substrates and may be specific for the assembly of iron sulfur enzymes (34, 40, 43).

<sup>1</sup>Unité Mixte de Recherche 1136 IaM (Interaction arbres microorganismes), INRA-UHP Nancy I. Université Henri Poincaré, 54506 Vandœuvre Cedex France.

<sup>2</sup>Medical Nobel Institute for Biochemistry, Department of Medical Biochemistry and Biophysics, Karolinska Institutet, S-171 77 Stockholm, Sweden.

<sup>3</sup>Biochemistry of Plants, Faculty of Biology, Ruhr-University, 44780 Bochum, Germany.

Sulfhydryls of cysteine residues are particularly exposed to reactive oxygen species (ROS) such as hydrogen peroxide ( $H_2O_2$ ) or superoxide anions, which are formed during normal aerobic growth or during oxidative stress (14). Formation of intermolecular disulfides or overoxidation of thiols to sulfenic, sulfinic or sulfonic acids can occur and thus lead to loss of enzymatic activity, aging, pathological disease, and cell death (3, 12). To challenge the overoxidation of thiols, cells possess a large battery of antioxidant enzymes, in which Trx and Grx play key roles. For example, Trx and/or Grx can reduce peroxiredoxins, non-heme peroxidases that catalyze the reduction of hydroperoxides (8, 36). Trx and Grx are also able to reduce protein-S-SG substrates forming under conditions of oxidative stress (9, 20).

Analysis of the transcriptional regulation and overexpression/deletion of different Trx and Grx isoforms under conditions of hydroperoxide stress has highlighted specific roles for particular genes (7, 13, 16, 24, 31). Two recent studies demonstrate that yeast Grx1 and a Grx from rice are able to reduce directly different alkyl hydroperoxides into alcohol, a reaction generally catalyzed by peroxidases (10, 22).

Whereas there are at least three "classical" dithiol Grxs in *E. coli* (CPYC active site), in yeast there are two of these proteins and three atypical ones with one active site cysteine (33, 34, 43). Apparently, there are only two classical Grxs in human (15, 25). In the genome of *Arabidopsis thaliana*, there are at least four classical Grxs and many other Grx-like proteins, but these proteins were not biochemically characterized and thus the understanding of the functions of Grxs in plants is not as advanced as in bacteria, yeast, or mammalian cells. The first plant Grxs were identified in spinach leaves, in the phloem sap of castor bean, and in the aleurone layer of rice (28, 29, 42). Until recently, the substrates of plant Grxs were unknown, whereas the range of substrates for bacterial Grxs includes redox-sensitive transcription factors (2, 11, 41). Plant Grxs possess dehydroascorbate reduction activity, and the Grx from poplar was demonstrated to be an efficient electron donor for a peroxiredoxin involved in the reduction of hydroperoxides (28, 35).

In this work, we describe the capacity for the poplar Grx to reduce *E. coli* RNR1a and PAPS reductase and to restore the growth of methionine auxotroph strains of *E. coli*, suggesting that plant Grxs can perform functions similar to those described in other organisms. Moreover, the involvement of the poplar Grx in the resistance to ROS was investigated by overexpressing the gene in an *E. coli* BL21(DE3) strain submitted to oxidative stress and by measuring the glutathione peroxidase activity of this Grx.

## MATERIALS AND METHODS

### Chemicals and reagents

NADPH was obtained from Boehringer Mannheim (Germany). Diamide,  $H_2O_2$ , tert-butyl hydroperoxide, menadione, dithiothreitol (DTT), glutathione reductase, and GSH were from Sigma (St. Louis, MO, U.S.A.). Isopropyl  $\beta$ -D-thiogalactoside (IPTG), kanamycin, and ampicillin were from Euromedex (France). All the recombinant Grx were purified as described (35).

### Cloning in pBAD and *E. coli* mutant strains complementation

A fragment encoding the poplar Grx was inserted between the restriction sites *NcoI* and *XhoI* of the plasmid pBADHisMyc and called pBAD Grx. This plasmid was used to transform the *E. coli* strains DHB4 *trxA*<sup>-</sup> *grxA*<sup>-</sup>, DHB4 *gor*<sup>-</sup> *trxA*<sup>-</sup>, and DHB4 *grxA*<sup>-</sup> *grxB*<sup>-</sup> *grxC*<sup>-</sup> (32, 44). The same strains transformed with the plasmid without insert were used as controls. Transformed strains were grown on M9 medium, supplied with Leu, Ile, and Met (50  $\mu$ g/ml) and ampicillin (100  $\mu$ g/ml). Single colonies were streaked on the same medium lacking Met but supplied with 0.2% arabinose and kept at 37°C for 48 h.

### Reduction of cytidine diphosphate (CDP) by *E. coli* RNR

Reduction of CDP by *E. coli* RNR1a was performed essentially as described (17). Reducing power was provided by 4 mM GSH, 1 mM NADPH, and 6  $\mu$ g/ml yeast glutathione reductase. All assays were performed in a total volume of 120  $\mu$ l. The catalytic rates reported represent the mean value of two independent measurements  $\pm$  1 SE.

### *E. coli* PAPS reductase activity measurement

PAPS reductase activity was measured as described (23) by following the formation of [<sup>35</sup>S]  $SO_3^{2-}$  from [<sup>35</sup>S]PAPS. The reaction mixture contained 100 mM Tris-HCl, pH 8.0, 3.3 nM PAPS reductase, 10 mM  $Na_2SO_3$ , 60–100  $\mu$ M [<sup>35</sup>S]PAPS (specific radioactivity: 1,700 Bq/nmol), and various amounts (0.5–70  $\mu$ M) of the wild-type (WT) poplar Grx and of an active-site mutant Grx Y29P, mimicking the active site of some plant Trxs. The Grxs were kept reduced by 5 mM GSH and 5 mM DTT.

### In vitro peroxidase activity of Grx

The peroxidase activity of poplar Grx was followed using two different spectrophotometric measurements with a Cary 50 spectrophotometer. Firstly, the consumption of  $H_2O_2$  was evaluated in a coupled reaction by following the oxidation of NADPH at 340 nm in the presence of the GSH/Grx system at 30°C. A reaction mixture of 500  $\mu$ l contained 50 mM Tris-HCl, pH 8.0, 2 mM EDTA, 150  $\mu$ M NADPH, 300  $\mu$ M GSH, 0.5 units of yeast glutathione reductase, and various concentrations of either WT Grx or of the two monocysteine mutants C27S and C30S. It was incubated for 1 min before the reaction was started by addition of 250  $\mu$ M  $H_2O_2$ . In the second test, the measurement of  $H_2O_2$  consumption was estimated using the Peroxoquant Quantitative Peroxide Assay from Pierce. A 50  $\mu$ l reaction mixture comprising 30 mM Tris-HCl, pH 8.0, 500  $\mu$ M DTT, 500  $\mu$ M  $H_2O_2$ , and various Grx concentrations (1–50  $\mu$ M) was incubated for 4–10 min at ambient temperature. An aliquot of 5  $\mu$ l was then added to the working reagent, and the absorbancy was measured 20 min later at 560 nm.

### Resistance of a Grx overexpressing *E. coli* strain to oxidants

The *E. coli* strain BL21(DE3), transformed with the helper plasmid pSBET, was cotransformed with the different

**FUNCTIONS OF POPLAR GLUTAREDOXIN**

recombinant pET plasmids (37). Single colonies, overexpressing the recombinant proteins, were streaked on Luria Bertani agar plates in the presence of 50 µg/ml ampicillin and kanamycin, 100 µM IPTG, and various concentrations of the oxidants. The cells were allowed to grow for 48 h at 37°C.

**RESULTS**

*Sequence analysis*

Grxs are ubiquitous proteins with a highly conserved structural fold, but the amino acid sequences are very divergent in different organisms. Phylogenetic analyses demonstrate that the plant Grx studied here belongs to the plant group, itself related to yeast and fungal Grxs (Fig. 1). The dendrogram shows clearly that those two groups are separated from the archae,

the eubacteria, and the mammalian ones. A sixth group is constituted by the 1-Cys Grx, well characterized in yeast. A comparison of selected Grxs relevant to this work is shown in Fig. 2. The closest protein is the arabidopsis Grxs (66% identity), followed distantly by rice and yeast Grx1 (39% identity). The *E. coli* Grx1 and human Grx1 exhibit only 30 and 29% identity, respectively. All these sequences possess a classical active site CP(F/Y)C and the amino acid motif involved with GSH binding (TVPX<sub>3</sub>GG). Nevertheless, the arabidopsis and the poplar Grxs are a bit elongated as they present an N-terminal extension of ~25 amino acids, whose function is unknown and dispensable (37).

*Reduction of E. coli RNR1a*

In order to explore the physiological functions of the plant Grxs, the poplar Grx was tested as a potential reductant for *E. coli* RNR1a, one of the three potential RNR of *E. coli*. In this

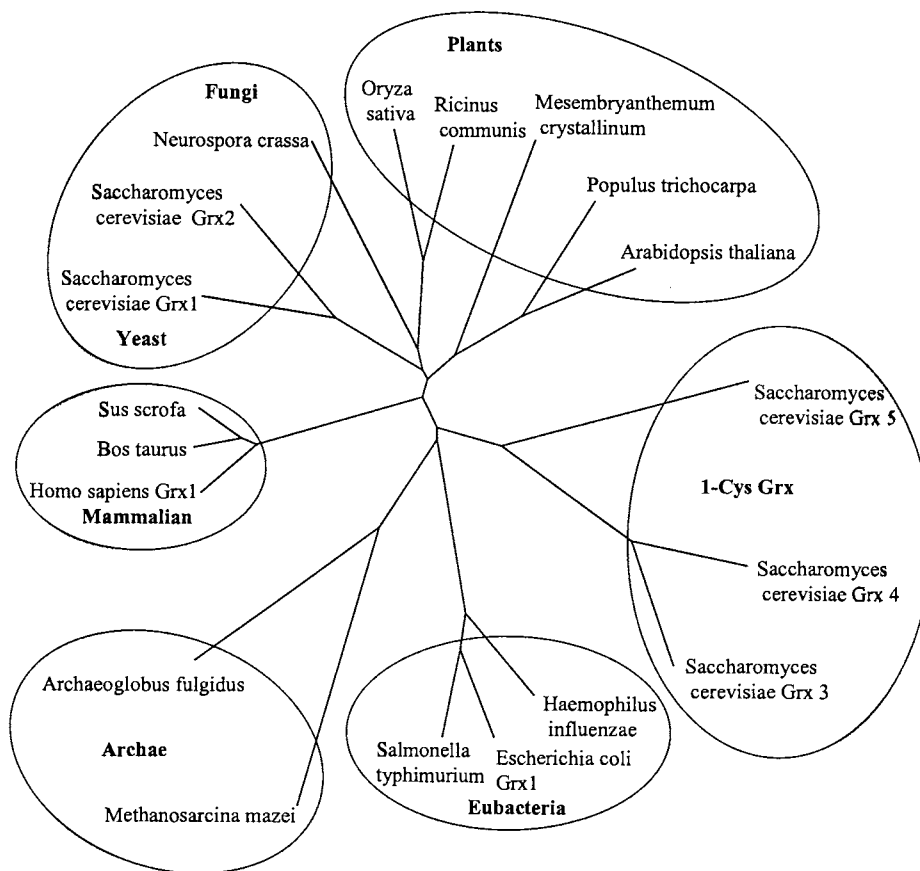

**FIG. 1. Dendrogram showing the amino acid sequence relationship between Grxs of different kingdoms.** The sequences were aligned with the clustalw software, and the tree was constructed using the Phylip program. Genbank accession numbers are as follows: NP-009895: *Saccharomyces cerevisiae* Grx1; NP-010801: *Saccharomyces cerevisiae* Grx2; NP-010383: *Saccharomyces cerevisiae* Grx3; NP-011101: *Saccharomyces cerevisiae* Grx4; NP-015266: *Saccharomyces cerevisiae* Grx5; BAA20071: *Oryza sativa*; T12219: *Mesembryanthemum crystallinum*; AAL90750: *Populus trichocarpa*; NP-197550: *Arabidopsis thaliana*; S54825: *Ricinus communis*; GDBO: *Bos taurus*; NP-415370: *Escherichia coli*; NP-002055: *Homo sapiens*; GDPG: *Sus scrofa*; I64127: *Haemophilus influenzae*; NP-459849: *Salmonella typhimurium*; P-635295: *Methanosarcina mazei*; NP-070365: *Archaeoglobus fulgidus*; CAB88564: *Neurospora crassa*.

\_\_\_ ls  
\_\_\_ le  
\_\_\_ ll

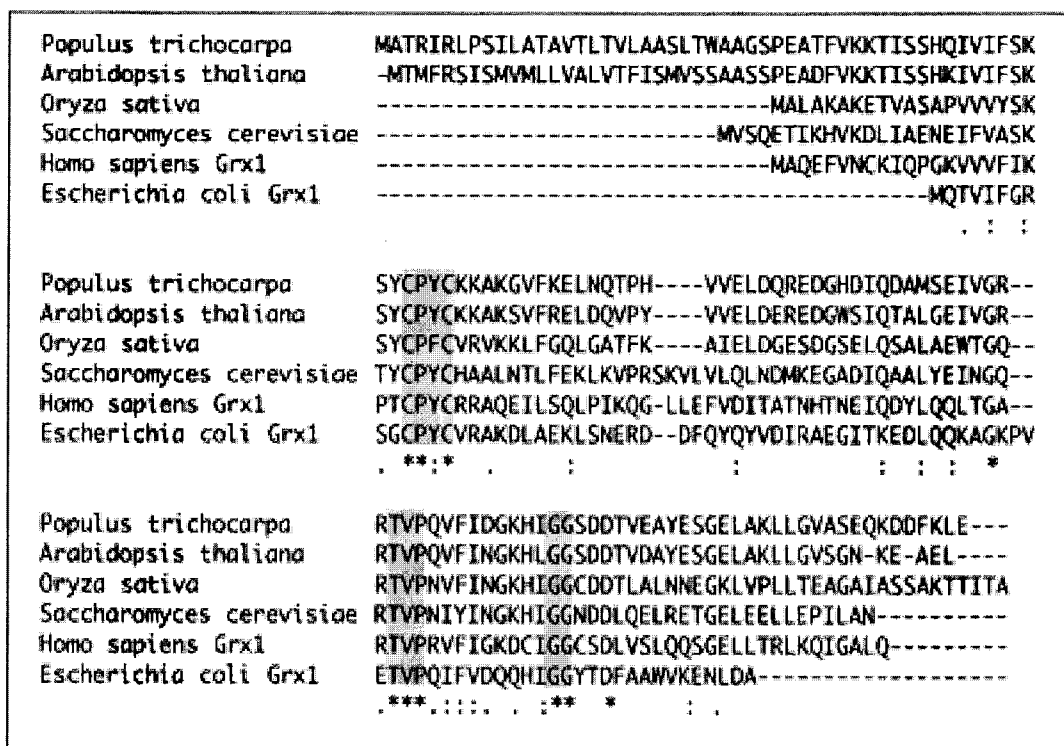

FIG. 2. Alignment of Grx amino acid sequences. Genbank accession numbers are given in Fig. 1. The yeast sequence is Grx1. The active site and the amino acids involved in the binding of glutathione are shaded.

organism, Trx1 and particularly Grx1 seem to be the best hydrogen donors for this enzyme (17, 30). *E. coli* Grx1 served as the positive control. Because of the low  $K_m$  of RNR1a for Grx1 (0.13  $\mu M$ ), the reduction of CDP reached a plateau at a concentration of Grx1 at 1  $\mu M$  (Fig. 3). In comparison, the saturation for the CDP reduction using poplar Grx was not reached even at a 5  $\mu M$  concentration of enzyme, demonstrating a poor activity with RNR1a. Nevertheless, the activity recorded is clearly above the background lacking Grx.

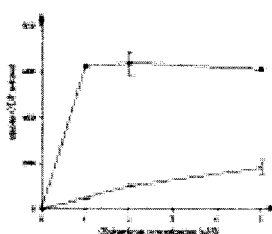

FIG. 3. CDP reduction by *Escherichia coli* RNR. The reduction of CDP by *E. coli* RNR1a was tested in the presence of the GSH system and various concentrations of *E. coli* Grx1 (closed diamonds) or poplar Grx (open circles). The values are the results of two measurements, and the background activity minus Grx was subtracted.

#### Poplar Grx is an in vitro and in vivo electron donor to *E. coli* PAPS reductase

Another enzyme that requires Grx for its reduction is PAPS reductase. The capacity of the poplar Grx to serve as an electron donor for this enzyme was investigated in two different ways. First, three *E. coli* strains defective in the Trx and/or Grx systems, unable to grow on minimal medium without Met as a source of sulfate, were functionally complemented with the poplar Grx (Fig. 4). The complementation of all the strains with the plasmid pBAD Grx rescued the growth on minimal medium, whereas the plasmid without insert did not. The observation that the *gor*<sup>-</sup> mutants can be complemented by Grx is related to their unexpected high content of GSH (44). This suggests that the poplar Grx can reduce PAPS reductase, the key thiol-dependent enzyme involved in sulfate assimilation in bacteria.

To confirm a direct interaction between these two partners, an *in vitro* assay with *E. coli* PAPS reductase was realized (Fig. 5). The Michaelis constants for the reactions utilizing WT Grx and a Y29P mutant that mimics Trx are shown in Table 1. The  $K_m$  values of the *E. coli* PAPS reductase for the WT poplar Grx and the Y29P mutant (57.0 and 43.2  $\mu M$ , respectively) are higher than those for *E. coli* Grx1 (14.9  $\mu M$ ), one of the three potential reductants of this enzyme along with Trx1 and Trx2. The rate of sulfite formation is a bit higher for the WT poplar Grx (9.6  $\mu mol/mg/min$ ) than for the

ls \_\_  
le \_\_  
ll \_\_

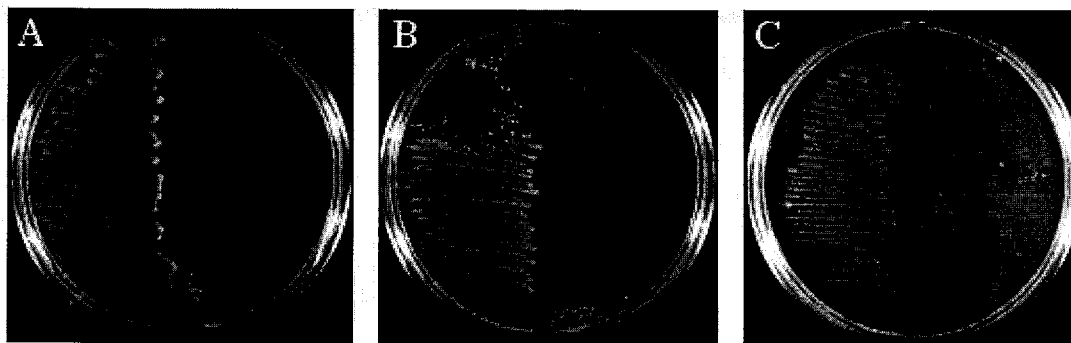

FIG. 4. Growth of DHB4*trxA-grxA*<sup>-</sup>, DHB4*gor-trxA*<sup>-</sup>, and DHB4*gor-grxA-B-C*<sup>-</sup> transformed with pBAD Grx on M9 minimal plates. *E. coli* strains DHB4*trxA-grxA*<sup>-</sup> (A), DHB4*gor-trxA*<sup>-</sup> (B), and DHB4*gor-grxA<sup>2</sup>B<sup>2</sup>C*<sup>-</sup> (C) were transformed with plasmids pBAD Grx (left) and pBADHisMyc (right) and grown on M9 medium lacking Met as described in Materials and Methods.

*E. coli* Grx1 (5.1  $\mu\text{mol}/\text{mg}/\text{min}$ ) and for the Y29P mutant (2.6  $\mu\text{mol}/\text{mg}/\text{min}$ ). Finally, the catalytic efficiency of *E. coli* Grx1 is superior to the two poplar Grxs.

#### Antioxidative properties of poplar Grx

Yeast Grx1 and a Grx from rice have glutathione peroxidase activity toward  $\text{H}_2\text{O}_2$  and other alkyl hydroperoxides (10, 22). The ability of the poplar Grx and of the C30S mutant to reduce  $\text{H}_2\text{O}_2$  and *tert*-butyl hydroperoxide was investigated by following the oxidation of NADPH in the presence of the glutathione/glutathione reductase system. At 300  $\mu\text{M}$  GSH, a slight reduction of  $\text{H}_2\text{O}_2$  was observed, but there was no further enhancement by adding Grx at concentrations ranging from 1 to 100  $\mu\text{M}$  (data not shown). To confirm that the poplar Grx was active, type II poplar peroxiredoxin was

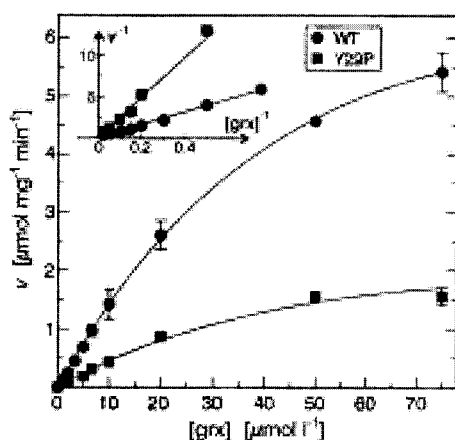

FIG. 5. WT and Y29P mutant of poplar Grx as electron donors for PAPS reductase *in vitro*. Michaelis-Menten and Lineweaver-Burk (inset) plots of  $V$  versus  $[\text{Grx}]$  are shown. The measurements were done as described in the Materials and Methods. Each point is derived from duplicates of three independent experiments. The kinetic constants were calculated using both nonlinear and linear curve fitting of the data sets.

TABLE 1. KINETIC CONSTANTS FOR Grx IN THE PAPS Reduction

	$K_m$ ( $\mu\text{M}$ )	$V_{max}$ ( $\mu\text{mol}/\text{mg}/\text{min}$ )	$K_{cat} K_m^{-1}$ ( $\text{M}^{-1} \text{s}^{-1}$ )
Poplar WT	57.0	9.6	$8.42 \times 10^4$
Poplar Y29P	43.2	2.6	$3.01 \times 10^4$
<i>E. coli</i> Grx1	14.9	5.1	$1.71 \times 10^5$

added directly to the reaction medium, resulting in a consumption of NADPH as described (36). The direct reduction of  $\text{H}_2\text{O}_2$  by glutathione could be bypassed in a second assay where DTT is the reductant and the consumption of  $\text{H}_2\text{O}_2$  is measured directly by a colorimetric assay. Varying the concentration of Grx from 1 to 50  $\mu\text{M}$  did not promote any reduction of  $\text{H}_2\text{O}_2$  either (data not shown).

As a conclusion, poplar Grx is not directly involved in the reduction of  $\text{H}_2\text{O}_2$  and other alkyl hydroperoxides. The hypothesis of an indirect effect was investigated by testing the resistance of the *E. coli* strain BL21(DE3) transformed with pET-3d encoding WT Grx and mutants C27S and C30S, in the presence of various oxidants. Transformants with pET-3d Grx grew well in the presence of 1 mM  $\text{H}_2\text{O}_2$ , 250  $\mu\text{M}$  *tert*-butyl hydroperoxide, and 500  $\mu\text{M}$  menadione, whereas transformants bearing the control plasmid (pET-3d) or pET-3d Grx C27S did not grow (Fig. 6). Resistance of BL21(DE3)-pET-3d Grx C30S and BL21(DE3)-pET-3d WT Grx was similar for  $\text{H}_2\text{O}_2$ , but not for *tert*-butyl hydroperoxide or menadione. Therefore, poplar Grx can act as a monothiol protein in response to  $\text{H}_2\text{O}_2$ , but only as a dithiol protein in response to *tert*-butyl hydroperoxide and menadione.

## DISCUSSION

Poplar Grx reduces *E. coli* RNR1a, but at very low rate compared with *E. coli* Grx1, the preferential hydrogen donor. This low activity of the poplar Grx is not unexpected, because Grxs are species-specific for the reduction of RNR (27). Although the activity obtained with the poplar Grx is low, it

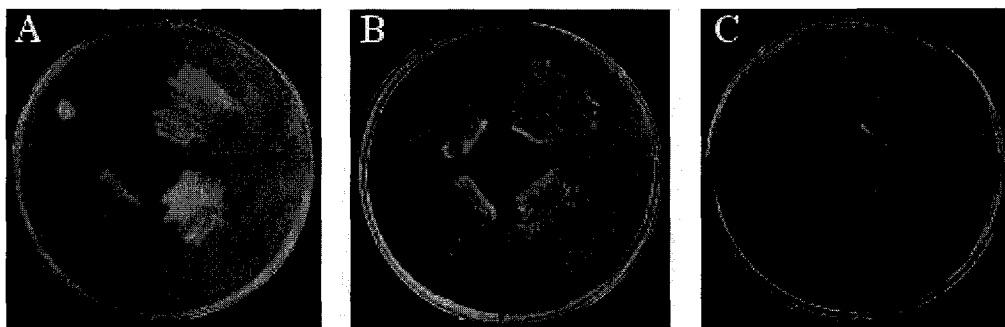

FIG. 6. Growth of *Escherichia coli* BL21(DE3) overexpressing poplar Grx on Luria Bertani plates in the presence of oxidants. Upper left: pET-3d alone; upper right: pET-3d Grx, lower left: pET-3d Grx C27S; lower right: pET-3d Grx C30S. (A) 1 mM  $H_2O_2$  treatment. (B) 250  $\mu M$  *tert*-butyl hydroperoxide. (C) 500  $\mu M$  menadione.

suggests a similar role for this protein in plants. It would thus be of interest to test this Grx and other similar proteins from poplar in a homologous system together with the RNR of the same source. Actually, only few biochemical data are available about plant RNR. The only enzyme biochemically characterized is a type 1a RNR from *Arabidopsis thaliana*, which *E. coli* Trx and two different cytosolic Trxs from *Arabidopsis thaliana* could reduce. No Grx was tested, however, in these assays (38).

The assimilation of inorganic sulfate into sulfide in many bacteria, including *E. coli*, occurs via a PAPS reductase (23). Recently, a diverse group of sulfate-assimilating bacteria was shown to use 5'-adenylsulfate (APS) instead of PAPS as a substrate for sulfate assimilation in a pathway analogous to higher plants (5). The *E. coli* PAPS reductase was shown to accept electrons provided by Trx1, Trx2, and Grx1, but not by Grx2 and Grx3, suggesting that there is a specificity between the different Grxs and the PAPS reductase in *E. coli* (23). The poplar Grx was shown here to reduce the PAPS reductase *in vitro* with a lower catalytic efficiency than *E. coli* Grx1. As sulfate assimilation is believed to occur mainly through APS reduction in plants, the physiological significance of this finding needs to be carefully evaluated. As discussed earlier, APS reductases possess, in addition to the domain homologous to the bacterial PAPS reductase, a C-terminal domain possessing a Grx activity (4). *In vitro*, GSH is an efficient hydrogen donor to APS reductase, suggesting that it reduces the Grx domain, which in turn reduces the APS reductase moiety. Nevertheless, the earlier purification of a PAPS-dependent reductase from spinach, together with the discovery of an alternative PAPS gene in knockout APS reductase mutants of *Physcomitrella patens*, raises the possibility of the existence of an alternative PAPS-dependent pathway in higher plants (21, 39). In this context, the capacity of the poplar Grx to reduce plant PAPS reductase could indeed be of physiological importance. The capacity for the poplar Grx to reduce the *E. coli* PAPS reductase was confirmed by complementation of three methionine auxotroph *E. coli* strains deficient in the Trx and Grx pathways. The introduction of the poplar Grx gene restored the growth of each strain in the absence of methionine, confirming that the poplar Grx is indeed able to serve as an electron donor to the PAPS reductase *in vivo*.

We investigated the antioxidative properties of poplar Grx as many studies have demonstrated the involvement of Grxs in the response to oxidative stress. Overexpression of the genes encoding Grx1 and Grx2 in yeast leads to increased resistance to  $H_2O_2$  and menadione, whereas mutant strains lacking these genes were sensitive to  $H_2O_2$  and the superoxide anion forming upon menadione treatment (24). In *E. coli*, lack of Grx activity has been related to increased carbonylation of intracellular proteins and sensitivity to  $H_2O_2$  (17). Yeast Grx1 and a rice Grx possess a high *in vitro* glutathione peroxidase activity (10, 22). This finding was unexpected for yeast as the organism has at least three phospholipid hydroperoxide reductases and five thiol peroxidases (7). We did not detect such an activity for poplar Grx *in vitro*, but its overexpression in *E. coli* increased resistance to  $H_2O_2$ , *tert*-butyl hydroperoxide, and menadione, suggesting an indirect role for this Grx. Poplar Grx is a good electron donor to a poplar type II peroxiredoxin and is also able to reduce dehydroascorbate into ascorbate, which is a common antioxidant found in many organisms and a reductant of ascorbate peroxidases (36). Whether poplar Grx is able to reduce the *E. coli* alkyl hydroperoxide reductases, periplasmic thiol peroxidase, or bacterio-comigratory protein is not known. Other potential roles for Grx are protein glutathionylation processes or reduction/oxidation of the transcription factor OxyR, which orchestrates the transcription of many antioxidant proteins in *E. coli* (7).

### Perspectives

Based on the data obtained in other organisms, plant Grxs could be involved in the reduction of selected target enzymes, transcription factors, or alternatively in the regulation of several proteins by reversible glutathionylation. These functions are not yet documented in plants. The possibility of regulation of transcriptional factor activity by Grx provides a means for the involvement of these proteins in the transduction of cellular signals or in the phenomenon of glutathionylation, very important in the response to oxidative stress. Interestingly, it is also likely that Grxs could participate in the long-distance signal transduction in plants, because they have been reported as one of the major protein species of the phloem

**FUNCTIONS OF POPLAR GLUTAREDOXIN**

sap together with Trx (42). Given the sensitivity of this tissue to pathogen attacks, it will be of interest to test whether Grx and Trx are also involved in pathogen-resistance mechanisms.

**ACKNOWLEDGMENTS**

This research was supported by grants to Jean-Pierre Jacquot from the Ministère de l'Éducation Nationale, and to Arne Holmgren from the Swedish Medical Research Council (13x-3529) and the Swedish Cancer Society (961).

**ABBREVIATIONS**

APS, 5'-adenylylsulfate; CDP, cytidine diphosphate; DTT, dithiothreitol; Grx, glutaredoxin; GSH, reduced glutathione; H<sub>2</sub>O<sub>2</sub>, hydrogen peroxide; IPTG, isopropylβ-D-thiogalactopyranoside; PAPS, 3'-phosphoadenylylsulfate; RNR, ribonucleotide reductase; ROS, reactive oxygen species; Trx, thioredoxin; WT, wild type.

**REFERENCES**

1. Aslund F, Ehn B, Miranda-Vizuete A, Pueyo C, and Holmgren A. Two additional glutaredoxins exist in *Escherichia coli*: glutaredoxin 3 is a hydrogen donor for ribonucleotide reductase in a thioredoxin/glutaredoxin 1 double mutant. *Proc Natl Acad Sci U S A* 91: 9813–9817, 1994.
2. Aslund F, Zheng M, Beckwith J, and Storz G. Regulation of the OxyR transcription factor by hydrogen peroxide and the cellular thiol-disulfide status. *Proc Natl Acad Sci U S A* 96: 6161–6165, 1999.
3. Berlett BS and Stadtman ER. Protein oxidation in aging, disease, and oxidative stress. *J Biol Chem* 272: 20313–20316, 1997.
4. Bick JA, Aslund F, Chen Y, and Leustek T. Glutaredoxin function for the carboxyl-terminal domain of the plant-type 5'-adenylylsulfate reductase. *Proc Natl Acad Sci U S A* 95: 8404–8409, 1998.
5. Bick JA, Dennis JJ, Zylstra GJ, Nowack J, and Leustek T. Identification of a new class of 5'-adenylylsulfate (APS) reductases from sulfate-assimilating bacteria. *J Bacteriol* 182: 135–142, 2000.
6. Bjornstedt M, Xue J, Huang W, Akesson B, and Holmgren A. The thioredoxin and glutaredoxin systems are efficient electron donors to human plasma glutathione peroxidase. *J Biol Chem* 269: 29382–29384, 1994.
7. Carmel-Harel O and Storz G. Roles of the glutathione- and thioredoxin-dependent reduction systems in the *Escherichia coli* and *Saccharomyces cerevisiae* responses to oxidative stress. *Annu Rev Microbiol* 54: 439–446, 2000.
8. Chae HZ, Chung SJ, and Rhee SG. Thioredoxin-dependent peroxide reductase from yeast. *J Biol Chem* 269: 27670–27678, 1994.
9. Chrestensen CA, Starke DW, and Mieczal JJ. Acute cadmium exposure inactivates thioltransferase (glutaredoxin), inhibits intracellular reduction of protein-glutathionyl- mixed disulfides, and initiates apoptosis. *J Biol Chem* 275: 26556–26565, 2000.
10. Collinson EJ, Wheeler GL, Garrido EO, Avery AM, Avery SV, and Grant CM. The yeast glutaredoxins are active as glutathione peroxidases. *J Biol Chem* 277: 16712–16717, 2002.
11. Daily D, Vlamis-Gardikas A, Offen D, Mittelman L, Melamed E, Holmgren A, and Barzilai A. Glutaredoxin protects cerebellar granule neurons from dopamine-induced apoptosis by activating NF-κappa B via Ref-1. *J Biol Chem* 276: 1335–1344, 2001.
12. Finkel T and Holbrook NJ. Oxidants, oxidative stress and the biology of aging. *Nature* 408: 239–247, 2000.
13. Garrido EO and Grant CM. Role of thioredoxins in the response of *Saccharomyces cerevisiae* to oxidative stress induced by hydroperoxides. *Mol Microbiol* 43: 993–1003, 2002.
14. Gille G and Sigler K. Oxidative stress and living cells. *Folia Microbiol* 40: 131–152, 1995.
15. Gladyshev VN, Liu A, Novoselov SV, Krysan K, Sun QA, Kryukov VM, Kryukov GV, and Lou MF. Identification and characterization of a new mammalian glutaredoxin (thioltransferase), Grx2. *J Biol Chem* 276: 30374–30380, 2001.
16. Grant CM. Role of the glutathione/glutaredoxin and thioredoxin systems in yeast growth and response to stress conditions. *Mol Microbiol* 39: 533–541, 2001.
17. Holmgren A. Glutathione-dependent synthesis of deoxyribonucleotides. Characterization of the enzymatic mechanism of *Escherichia coli* glutaredoxin. *J Biol Chem* 254: 3672–3678, 1979.
18. Holmgren A. Thioredoxin and glutaredoxin systems. *J Biol Chem* 264: 13963–13966, 1989.
19. Holmgren A. Antioxidant function of thioredoxin and glutaredoxin systems. *Antioxid Redox Signal* 2: 811–820, 2000.
20. Klatt P and Lamas S. Regulation of protein function by S-glutathiolation in response to oxidative and nitrosative stress. *Eur J Biochem* 267: 4928–4944, 2000.
21. Koprivova A, Meyer AJ, Schween G, Herschbach C, Reski R, and Kopriva S. Functional knockout of the adenosine 5'-phosphosulfate reductase gene in *Physcomitrella patens* revives an old route of sulfate assimilation. *J Biol Chem* 277: 32195–32201, 2002.
22. Lee KO, Lee JR, Yoo JY, Jang HH, Moon JC, Jung BG, Chi YH, Park SK, Lee SS, Lim CO, Yun DJ, Cho MJ, and Lee SY. GSH-dependent peroxidase activity of the rice (*Oryza sativa*) glutaredoxin, a thioltransferase. *Biochem Biophys Res Commun* 296: 1152–1156, 2002.
23. Lillig CH, Prior A, Schwenn JD, Aslund F, Ritz D, Vlamis-Gardikas A, and Holmgren A. New thioredoxins and glutaredoxins as electron donors of 3'-phosphoadenylylsulfate reductase. *J Biol Chem* 274: 7695–7698, 1999.
24. Luikenhuis S, Perrone G, Dawes IW, and Grant CM. The yeast *Saccharomyces cerevisiae* contains two glutaredoxin genes that are required for protection against reactive oxygen species. *Mol Biol Cell* 9: 1081–1091, 1998.
25. Lundberg M, Johansson C, Chandra J, Enoksson M, Jacobsson G, Ljung J, Johansson M, and Holmgren A. Cloning and expression of a novel human glutaredoxin



- with mitochondrial and nuclear isoforms. *J Biol Chem* 276: 26269–26275, 2001.
26. Lundstrom-Ljung J, Vlamis-Gardikas A, Aslund F, and Holmgren A. Reactivity of glutaredoxins 1, 2 and 3 from *Escherichia coli* and protein disulfide isomerase towards glutathionyl-mixed disulfides in ribonuclease A. *FEBS Lett* 443: 85–88, 1999.
  27. Luthman M, Eriksson S, Holmgren A, and Thelander L. Glutathione-dependent hydrogen donor system for calf thymus ribonucleoside-diphosphate reductase. *Proc Natl Acad Sci U S A* 76: 2158–2162, 1979.
  28. Minakuchi K, Yabushita T, Masumura T, Ichihara K, and Tanaka K. Cloning and sequence analysis of a cDNA encoding rice glutaredoxin. *FEBS Lett* 337: 157–160, 1994.
  29. Morell S, Follmann H, and Haberlein I. Identification and localization of the first glutaredoxin in leaves of a higher plant. *FEBS Lett* 369: 149–152, 1995.
  30. Potamitou A, Holmgren A, and Vlamis-Gardikas A. Protein levels of *Escherichia coli* thioredoxins and glutaredoxins and their relation to null mutants, growth phase, and function. *J Biol Chem* 277: 18561–18567, 2002.
  31. Prieto-Alamo MJ, Jurado J, Gallardo-Madueno R, Monje-Casas F, Holmgren A, and Pueyo C. Transcriptional regulation of glutaredoxin and thioredoxin pathways and related enzymes in response to oxidative stress. *J Biol Chem* 275: 13398–13405, 2000.
  32. Prinz WA, Aslund F, Holmgren A, and Beckwith J. The role of the thioredoxin and glutaredoxin pathways in reducing protein disulfide bonds in the *Escherichia coli* cytoplasm. *J Biol Chem* 272: 15661–15667, 1997.
  33. Qin J, Yang Y, Velyvis A, and Gronenborn A. Molecular views of redox regulation: three-dimensional structures of redox regulatory proteins and protein complexes. *Antioxid Redox Signal* 2: 827–840, 2000.
  34. Rodriguez-Manzaneque MT, Ros J, Cabisco E, Sorribas A, and Herrero E. Grx5 glutaredoxin plays a central role in protection against protein oxidative damage in *Saccharomyces cerevisiae*. *Mol Cell Biol* 19: 8180–8190, 1999.
  35. Rouhier N, Gelhaye E, and Jacquot JP. Exploring the active site of plant glutaredoxin by site-directed mutagenesis. *FEBS Lett* 511: 145–149, 2002.
  36. Rouhier N, Gelhaye E, and Jacquot JP. Glutaredoxin-dependent peroxiredoxin from poplar. Protein-protein interaction and catalytic mechanism. *J Biol Chem* 277: 13609–13614, 2002.
  37. Rouhier N, Gelhaye E, Sautiere PE, and Jacquot JP. Enhancement of poplar glutaredoxin expression by optimization of the cDNA sequence. *Protein Expr Purif* 24: 234–241, 2002.
  38. Sauge-Merle S, Falconet D, and Fontecave M. An active ribonucleotide reductase from *Arabidopsis thaliana* cloning, expression and characterization of the large subunit. *Eur J Biochem* 266: 62–69, 1999.
  39. Schwenn JD. Sulphate assimilation in higher plants: a thioredoxin PAPS reductase from spinach leaves. *Z Naturforsch [C]* 4: 504–508, 1989.
  40. Shenton D, Perrone G, Quinn KA, Dawes IW, and Grant CM. Regulation of protein S-thiolation by glutaredoxin 5 in the yeast *Saccharomyces cerevisiae*. *J Biol Chem* 277: 16853–16859, 2002.
  41. Shi J, Vlamis-Gardikas A, Aslund F, Holmgren A, and Rosen BP. Reactivity of glutaredoxins 1, 2, and 3 from *Escherichia coli* shows that glutaredoxin 2 is the primary hydrogen donor to ArsC-catalyzed arsenate reduction. *J Biol Chem* 274: 36039–36042, 1999.
  42. Szederkenyi J, Komor E, and Schobert C. Cloning of the cDNA for glutaredoxin, an abundant sieve-tube exudate protein from *Ricinus communis* L. and characterisation of the glutathione-dependent thiol-reduction system in sieve tubes. *Planta* 202: 349–356, 1997.
  43. Vlamis-Gardikas A and Holmgren A. Thioredoxin and glutaredoxin isoforms. *Methods Enzymol* 347: 286–296, 2002.
  44. Vlamis-Gardikas A, Potamitou A, Zarivach R, Hochman A, and Holmgren A. Characterization of *Escherichia coli* null mutants for glutaredoxin 2. *J Biol Chem* 277: 10861–10868, 2002.

Address reprint requests to:

Dr. Jean-Pierre Jacquot  
Unité Mixte de Recherche 1136 IaM  
(Interaction arbres microorganismes)  
INRA-UHP Nancy I. Université Henri Poincaré  
54506 Vandoeuvre Cedex, France

E-mail: j2p@scbiol.uhp-nancy.fr

Received for publication September 10, 2002; accepted October 7, 2002.

Article numéro 10 :

**d'Ambrosio K, Kauffmann B, Rouhier N, Benedetti E, Jacquot JP, Aubry A, Corbier C.**

*Crystallization and preliminary X ray data of poplar glutaredoxin.*

***Acta Crystallogr. D Biol. Crystallogr., sous presse.***

Les seules structures tridimensionnelles de Grx connues pour l'instant sont 4 protéines d'*E. coli*, 3 Grx bicystéiniques et une protéine homologue NrdH, une Grx du phage T<sub>4</sub>, et enfin les Grx porcine et humaine. Ces structures ont été résolues soit par RMN soit par cristallographie. Différentes conditions ont été testées pour la Grx de peuplier, mais ni la protéine sauvage ni aucun des mutants du site actif sous forme réduite ou oxydée n'ont cristallisé correctement. Finalement, la solution a été de fixer du GSH de manière covalente sur le mutant de la deuxième cystéine du site actif, Grx C30S. Ensuite, une fois les conditions de cristallisation connues, la protéine mutante a été exprimée dans une souche d'*E. coli* auxotrophe pour la méthionine, sur milieu minimum et en présence de sélénométhionine. En effet, la faible identité de séquence entre la Grx de peuplier et les Grx de structure connue imposait d'avoir recours au marquage par la sélénométhionine puisque la méthode de remplacement moléculaire n'a pas permis de résoudre la structure. L'incorporation de la sélénométhionine de manière homogène dans toutes les molécules a été vérifiée par spectrométrie de masse en mode électrospray (augmentation de masse de 47.1 Da). Les cristaux obtenus diffractent à 1.73Å, permettant de déterminer la première structure 3D de Grx de plantes. La description de cette structure fera l'objet d'un article séparé.

Acta Crystallographica Section D  
 Biological  
 Crystallography  
 ISSN 0907-4449

## Crystallization and preliminary X-ray studies of the glutaredoxin from poplar in complex with glutathione

Katia D'Ambrosio,<sup>a,b</sup> Brice Kauffmann,<sup>a</sup> Nicolas Rouhier,<sup>c</sup> Ettore Benedetti,<sup>b</sup> Jean-Pierre Jacquot,<sup>c</sup> André Aubry<sup>a</sup> and Catherine Corbier<sup>a\*</sup>

<sup>a</sup>LCM3B, Groupe Biocristallographie, UMR CNRS 7036, UHP-Nancy 1, Faculté des Sciences, BP 239, 54506 Vandoeuvre-lès-Nancy CEDEX, France, <sup>b</sup>Istituto di Biostrutture e Bioimmagini, CNR, Dipartimento di Chimica Biologica, Università degli Studi di Napoli 'Federico II', 80134 Napoli, Italy, and <sup>c</sup>Interactions Arbres Microorganismes UMR 1136 INRA, UHP-Nancy 1, Faculté des Sciences, BP 239, 54506 Vandoeuvre-lès-Nancy CEDEX, France

Correspondence e-mail:  
 corbier@lcm3b.uhp-nancy.fr

A monocysteine mutant of poplar glutaredoxin (C30S) has been overproduced and purified. The protein has been crystallized in complex with glutathione using the hanging-drop vapour-diffusion technique in the presence of PEG 4000 as a precipitating agent. A native data set was collected at 1.55 Å resolution. The crystals belong to space group  $P2_12_12_1$ , with unit-cell parameters  $a = 45.9$ ,  $b = 49.2$ ,  $c = 105.1$  Å. Isomorphous crystals of a selenomethionine derivative were grown under the same conditions. Three data sets were collected at 1.73 Å using the FIP synchrotron beamline at the ESRF. The positions of the Se atoms were determined and model rebuilding and refinement are in progress.

Received 18 December 2002  
 Accepted 24 March 2003

### 1. Introduction

Glutaredoxins (GRXs), also called thiol-transferases, are low-molecular-weight proteins (generally between 80 and 100 amino acids) which belong to the protein disulfide oxidoreductase class. The major function of proteins of this class is to selectively reduce disulfide bridges on other proteins (glutaredoxin or thioredoxin) or alternatively to oxidize close cysteine residues in order to create new disulfide bridges (protein disulfide isomerase) (Holmgren, 2000). These reactions are needed either for the regulation of enzymatic activities or for protein folding in cells. The best known member of this class is thioredoxin (TRX), also a small protein (typically ~110 amino acids), for which numerous structural models are available. One of the major differences between TRXs and GRXs is their mode of reduction. In plants, depending on its subcellular compartmentation, TRX is reduced either by the photosynthetic electron flow *via* ferredoxin and an iron-sulfur protein, ferredoxin thioredoxin reductase (chloroplast system), or by NADPH and a flavoenzyme, NADPH thioredoxin reductase (cytosolic and mitochondrial systems) (Meyer *et al.*, 1999). In contrast, GRX is reduced by glutathione, which is itself kept reduced by NADPH and the flavoenzyme glutathione reductase. Another difference relates to the active-site sequence, which is generally YCPYC in GRX rather than the usual WCGPC of TRX. The redox potentials of the disulfide bridge of the GRXs characterized so far are generally more positive by ~50 mV than those of TRXs (Åslund *et al.*, 1997; Prinz *et al.*, 1997). As a consequence, GRXs are considered to be weaker reductants than TRXs. Furthermore, GRX is able to function as a monocysteine

enzyme, while TRX is inactive in this configuration (Yang *et al.*, 1998).

Several three-dimensional structures of GRXs are currently available, but proteins from only four sources have been studied so far: the *Escherichia coli*, bacteriophage T<sub>4</sub>, pig and human enzymes. All available structures of the *E. coli* GRXs have been solved by NMR [PDB codes 1qfn (Berardi & Bushweller, 1999), 1grx (Bushweller *et al.*, 1992), 1egr (Sodano *et al.*, 1991) and 1ego (Xia *et al.*, 1992) for Grx 1, 1g7o (Xia *et al.*, 2001) for Grx2 and 3grx (Nordstrand *et al.*, 1999) and 1fov (Nordstrand *et al.*, 2000) for Grx3]. NMR structures are also available for T<sub>4</sub> GRX (1de1 and 1de2; Wang & Wishart, unpublished results) and human GRX [1b4q (Yang *et al.*, 1998) and 1jhb (Sun *et al.*, 1998)]. Only four X-ray structures are currently available, one of *E. coli* Nrdh, a GRX homologue of only 81 amino acids (1h75; Stehr *et al.*, 2001), two of the T<sub>4</sub> GRX (1aaz and 1aba; Eklund *et al.*, 1992) and one of the pig enzyme (1kte; Katti *et al.*, 1995). All models show a similar sequence of secondary elements. The active site is consistently situated at the beginning of the first  $\alpha$ -helix. In all sequences, the amino acids responsible for the binding of glutathione are conserved. When the GRX models are compared with those of TRX, it is apparent that the short GRXs lack the first  $\beta$ -strand and  $\alpha$ -helix found at the N-terminus of TRX, but that the two proteins share the same overall fold, named the TRX fold.

The poplar GRX studied here is an interesting model both biologically and structurally. It possesses only a low sequence identity with the GRX for which a three-dimensional structure is currently available; next to the unusually long Grx2, it is the longest GRX isolated so far (112 amino acids; the next

## crystallization papers

longest is the mammalian type with 106 residues; Rouhier *et al.*, 2002). This is the first GRX from a plant that has been crystallized so far and the first X-ray structure of a GRX in complex with glutathione. Interestingly, this protein has been demonstrated to be an efficient donor to a peroxiredoxin, an enzyme which is able to selectively remove various hydroperoxides (Rouhier *et al.*, 2001, 2002b). This property has not been reported in other species so far; the various peroxiredoxins studied instead use TRX as an electron donor. It is thus of great interest to study the molecular interaction between the two proteins in this unique system. We have recently reported the crystallization and preliminary X-ray data of the peroxiredoxin component (Echalier *et al.*, 2002). This paper reports parallel work on GRX, the other partner in this model protein-protein interaction.

## 2. Material and methods

### 2.1. Cloning, expression and purification

The cloning, expression and purification of wild-type and C30S mutant poplar GRX has been described in Rouhier *et al.* (2002, 2002a). Typically, 100 mg of homogeneous protein was obtained and was stored frozen in 1 ml aliquots in 30 mM Tris-HCl containing 1 mM EDTA and 14 mM  $\beta$ -mercaptoethanol at a concentration of 15 mg ml<sup>-1</sup> at 252 K. The purity of the fractions was monitored by SDS-PAGE.

For the production of the selenomethionine-substituted GRX, a special strain deficient in methionine synthesis [BL21(DE3)Met<sup>-</sup>] was cotransformed by pET-Grx and pSBET. One ampicillin- and kanamycin-resistant colony was amplified to 1 l in M9 medium supplemented with all 19 regular amino acids and selenomethionine each at 50 mg ml<sup>-1</sup>. When the culture reached the exponential stage, protein synthesis was induced by the addition of 100  $\mu$ M IPTG. The subsequent purification procedure was identical to that for the native protein. Selenomethionine substitution was checked by electrospray mass-spectrometry analysis. A mass increase of 47.1 Da was observed compared with the native protein, as expected from the presence of one SeMet residue per molecule.

### 2.2. Site-directed mutagenesis and preparation of the mixed glutaredoxin-glutathione complex

In order to isolate a stable mixed disulfide intermediate between GRX and glutathione, the second active-site cysteine has been

**Table 1**

Statistics of the X-ray diffraction data for the SeMet GRX crystals.

Values in parentheses refer to the highest resolution shell.

	Peak	Edge	Remote
Wavelength (Å)	0.9802	0.9804	0.9724
Resolution (Å)	1.73 (1.77–1.73)	1.73 (1.77–1.73)	1.73 (1.77–1.73)
Observed reflections	143400	167434	169462
Unique reflections	46336	46285	46954
Completeness (%)	96.1 (92.0)	96.4 (89.6)	97.9 (93.0)
Multiplicity	3.09	3.62	3.61
$R_{\text{sym}}$ (%)	4.1 (13.3)	4.0 (19.8)	4.7 (36.6)
$I/\sigma(I)$	18.2 (3.4)	17.0 (2.3)	13.7 (2.0)
Mean figure of merit before solvent flattening	0.386		
Mean figure of merit after solvent flattening	0.899		

replaced by Ser using the PCR strategy described in Rouhier *et al.* (2002a). The C30S mutated protein (40 mg ml<sup>-1</sup>) was mixed with an equal volume of 100 mM phosphate buffer containing 1 mM EDTA at pH 8.0. The sample was reduced with 100 mM DTT for 15 min at 277 K. Glutathione disulfide (GSSG) was subsequently added to a concentration of 500 mM. After 30 min incubation at 277 K, excess GSSG was removed by gel filtration using a Sephadex G25 column pre-equilibrated with 50 mM phosphate buffer pH 6.0. The concentration was determined by UV absorption at 276 nm, using a molar extinction coefficient of 4350 M<sup>-1</sup> cm<sup>-1</sup>.

### 2.3. Crystallization

Crystallization experiments were carried out using the hanging-drop vapour-diffusion method (McPherson, 1999). The search for initial crystallization conditions was performed using Hampton Research Crystal Screen kits I and II (Jancarik & Kim, 1991; Cudney *et al.*, 1994) and Clear Strategy Screens (Molecular Dimensions Ltd). The wells contained 800  $\mu$ l of precipitant solution and the drops were composed of 2  $\mu$ l of reservoir solution and 2  $\mu$ l of protein solution at various concentrations. The most promising crystallization conditions were refined by variation of protein or precipitant concentrations, pH or the ratio of protein to reservoir in the droplet. Finally, the best crystals were obtained at a protein concentration of 6.5 mg ml<sup>-1</sup> from a solution containing 28% PEG 4000 and 0.2 M (NH<sub>4</sub>)<sub>2</sub>SO<sub>4</sub> at 285 K.

### 2.4. Data collection

X-ray diffraction experiments were carried out at 100 K. Since the crystallization solution was suitable to provide cryo-protection, the crystals were quickly washed in the reservoir solution and immediately flash-frozen in a nitrogen-gas stream at 100 K. The data sets for the native protein or

for the selenomethionyl derivative were collected on beamline BM30A (FIP; Roth *et al.*, 2002) at the ESRF, using a MAR Research 345 image-plate detector. For the latter data set, three wavelengths were chosen from the fluorescence spectrum corresponding to the peak, inflection point and high-energy remote. The data were processed using DENZO and scaled with SCALEPACK (Otwinowski & Minor, 1997). Statistics of the data are presented in Table 1.

## 3. Results and discussion

In our hands, crystallization trials using standard procedures failed to produce crystals from the wild-type protein or for several variants of the active site. However, the use of a monocysteine mutant (C30S) allowed us to obtain a stable mixed disulfide complex (C30S-glutathione) that crystallized within 1 d under the conditions described above (Fig. 1). Crystals belong to space group  $P2_12_12_1$ , with unit-cell parameters  $a = 45.7$ ,  $b = 49.09$ ,  $c = 104.81$  Å (Table 2). A native data set was collected at 1.55 Å resolution. Molecular-replacement trials using the program AMoRe and performed using the



**Figure 1**  
Crystals of C30S GRX in complex with glutathione (approximate dimensions 0.5 × 0.1 × 0.02 mm).

## crystallization papers

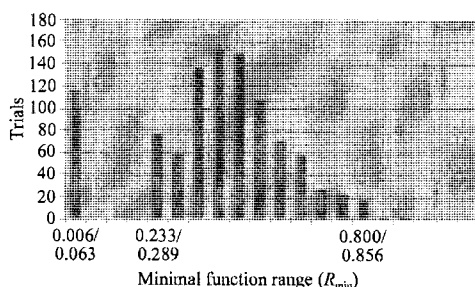
**Figure 2**

Histogram of the number of trials and their corresponding minimal function values  $R_{\min}$  obtained with *Shake-and-Bake* (*SnB*). Using 700 reflections selected in the resolution range 25–1.66 Å and 230 invariants, a maximum of four sites were searched for 1000 trials of 20 cycles each. Two sites were found in 118 successful trials. The best value of  $R_{\min}$  is 0.006.

**Table 2**

Crystallization conditions of the GRX–glutathione complex and X-ray characterization.

Protein concentration (mg ml <sup>-1</sup> )	6.5
Crystallization solution	28% PEG 4000, 0.2 M (NH <sub>4</sub> ) <sub>2</sub> SO <sub>4</sub>
Crystal dimensions (mm)	0.5 × 0.2 × 0.02
Unit-cell parameters (Å)	$a = 45.7$ , $b = 49.09$ , $c = 104.81$
Space group	$P2_12_12_1$
Molecules per asymmetric unit	2
$V_M$ (Å <sup>3</sup> Da <sup>-1</sup> )	2.49
Solvent content (%)	49
Diffraction limit (Å)	1.55

coordinates of the closest GRXs as search models were unsuccessful. A SeMet-substituted protein was therefore prepared and crystallized under the same conditions. Crystals only appeared after one month, but could be obtained within one week by the use of microseeding techniques. Three data sets were collected at three wavelengths to 1.73 Å resolution (Table 1). A search for the positions of two Se atoms per asymmetric unit was performed with the data set collected at the peak of the selenium *K* edge using either the Patterson method (*CNS*; Brünger *et al.*, 1998) or direct methods (*Shake-and-Bake* version 2.1; Weeks & Miller, 1999) (Fig. 2). Both methods unambiguously allowed the identification of the same two sites, as expected from the presence of one molecule of SeMet per molecule and two molecules per asymmetric

unit. Peak-wavelength structure factors were phased with *SHARP* (de La Fortelle & Bricogne, 1997) to 1.73 Å resolution and the phases were improved by solvent flattening using *DM* (Collaborative Computational Project, Number 4, 1994) and *SOLOMON* (Abrahams & Leslie, 1996). Automatic model building with *ARP/wARP* (Perrakis *et al.*, 1999) led to the repositioning of 95 of 112 residues, with *R* and *R<sub>free</sub>* values of 20 and 25% at the beginning of the refinement process. Model completion and refinement are currently in progress.

We would like to thank J. L. Ferrer at the ESRF for his help during data collection. We are very grateful to Dr Claude Schaubert for determining the molecular weight of the native GRX and of the SeMet derivative.

**References**

- Abrahams, J. P. & Leslie, A. G. W. (1996). *Acta Cryst.* **D52**, 30–42.
- Åslund, F., Berndt, K. D. & Holmgren, A. (1997). *J. Biol. Chem.* **272**, 30780–30786.
- Berardi, M. J. & Bushweller, J. H. (1999). *J. Mol. Biol.* **292**, 151–161.
- Brünger, A. T., Adams, P. D., Clore, G. M., DeLano, W. L., Gros, P., Grosse-Kunstleve, R. W., Jiang, J. S., Kuszewski, J., Nilges, M., Pannu, N. S., Read, R. J., Rice, L. M., Simonson, T. & Warren, G. L. (1998). *Acta Cryst.* **D54**, 905–921.
- Bushweller, J. H., Åslund, F., Wuthrich, K. & Holmgren, A. (1992). *Biochemistry*, **31**, 9288–9293.
- Collaborative Computational Project, Number 4 (1994). *Acta Cryst.* **D50**, 760–763.
- Cudney, R., Patel, S., Weisgraber, K., Newhouse, Y. & McPherson, A. (1994). *Acta Cryst.* **D50**, 414–423.
- Echalier, A., Corbier, C., Rouhier, N., Jacquot, J. P. & Aubry, A. (2002). *Acta Cryst.* **D58**, 1501–1503.
- Eklund, H., Ingelman, M., Söderberg, B. O., Uhlin, T., Nordlund, P., Nikkila, M., Sonnerstam, U., Joelson, T. & Petratos, K. (1992). *J. Mol. Biol.* **228**, 596–618.
- Holmgren, A. (2000). *Antioxid. Redox Signal.* **2**, 811–820.
- Jancarik, J. & Kim, S.-H. (1991). *J. Appl. Cryst.* **24**, 409–411.
- Katti, S. K., Robbins, A. H., Yang, Y. & Wells, W. W. (1995). *Protein Sci.* **4**, 1998–2005.
- La Fortelle, E. de & Bricogne, G. (1997). *Methods Enzymol.* **276**, 472–494.
- McPherson, A. (1999). *Crystallization of Biological Macromolecules*. New York: Cold Spring Harbor Laboratory Press.
- Meyer, Y., Verdoucq, L. & Vignols, F. (1999). *Trends Plant Sci.* **4**, 388–394.
- Nordstrand, K., Åslund, F., Holmgren, A., Otting, G. & Berndt, K. D. (1999). *J. Mol. Biol.* **286**, 541–552.
- Nordstrand, K., Sandstrom, A., Åslund, F., Holmgren, A., Otting, G. & Berndt, K. D. (2000). *J. Mol. Biol.* **303**, 423–432.
- Otwinowski, Z. & Minor, W. (1997). *Methods Enzymol.* **276**, 307–326.
- Perrakis, A., Morris, R. J. & Lamzin, V. (1999). *Nature Struct. Biol.* **6**, 458–463.
- Prinz, W. A., Åslund, F., Holmgren, A. & Beckwith, J. (1997). *J. Biol. Chem.* **272**, 15661–15667.
- Roth, M., Carpentier, P., Kaikati, O., Joly, J., Charraut, P., Pirocchi, M., Kahn, R., Fanchon, E., Jacquamet, L., Borel, F., Bertoni, A., Israel-Gouy, P. & Ferrer, J. L. (2002). *Acta Cryst.* **D58**, 805–814.
- Rouhier, N., Gelhaye, E. & Jacquot, J. P. (2002a). *FEBS Lett.* **511**, 145–149.
- Rouhier, N., Gelhaye, E. & Jacquot, J. P. (2002b). *J. Biol. Chem.* **277**, 13609–13614.
- Rouhier, N., Gelhaye, E., Sautiere, P. E., Brun, A., Laurent, P., Tagu, D., de Fay, E., Meyer, Y. & Jacquot, J. P. (2001). *Plant Physiol.* **127**, 1299–1309.
- Rouhier, N., Gelhaye, E., Sautiere, P. E. & Jacquot, J. P. (2002). *Protein Expr. Purif.* **24**, 234–241.
- Sodano, P., Xia, T. H., Bushweller, J. H., Bjornberg, O., Holmgren, A., Billeter, M. & Wuthrich, K. (1991). *J. Mol. Biol.* **221**, 1311–1324.
- Stehr, M., Schneider, G., Åslund, F., Holmgren, A. & Lindqvist, Y. (2001). *J. Biol. Chem.* **276**, 35836–35841.
- Sun, C., Berardi, M. J. & Bushweller, J. H. (1998). *J. Biol. Chem.* **280**, 687–701.
- Weeks, C. M. & Miller, R. (1999). *Acta Cryst.* **D55**, 492–500.
- Xia, B., Vlamis-Gardikas, A., Holmgren, A., Wright, P. E. & Dyson, H. J. (2001). *J. Mol. Biol.* **310**, 907–918.
- Xia, T. H., Bushweller, J. H., Sodano, P., Billeter, M., Bjornberg, O., Holmgren, A. & Wuthrich, K. (1992). *Protein Sci.* **1**, 310–321.
- Yang, Y., Jao, S., Nanduri, S., Starke, D. W., Mielay, J. J. & Qin, J. (1998). *Biochemistry*, **37**, 17145–17156.



---

## *Chapitre II : les protéines cibles*

Un des objectifs de mon travail de thèse était d'identifier des protéines cibles des Trx cytosoliques ou de la Grx de peuplier isolées par notre équipe. Différentes approches sont possibles, de la technique du double hybride, à l'utilisation de monobromobimane (mBBBr), un produit fluorescent qui réagit avec les groupements thiols ou à la création de mutants monocystéiniques pouvant être utilisés soit pour créer des colonnes d'affinité et retenir de manière covalente des protéines cibles soit pour réaliser des expériences d'immunoprécipitation (Verdoucq *et al.*, 1999 ; Motohashi *et al.*, 2001 ; Yano *et al.*, 2001 ; Balmer *et al.*, 2003 ; Vignols *et al.*, 2003). Par ailleurs, Trx et Grx ayant une fonction et un mode d'action commun, il n'est pas illusoire de penser qu'elles peuvent réduire les même protéines. En effet, même si leurs potentiels rédox et leurs séquences primaires sont différents, leurs structures tridimensionnelles sont très voisines. Ainsi, plusieurs enzymes ou protéines possèdent cette capacité d'être réduite par les Trx ou les Grx. C'est le cas notamment de la PAPS réductase ou de la RNR d'*E. coli* et d'une Gpx ou de divers facteurs de transcription tels que AP 1 ou Nf-kB de mammifères (Bjornstedt *et al.*, 1994 ; Prinz *et al.*, 1997 ; Lillig *et al.*, 1999 ; Hirota *et al.*, 2000).

Actuellement, un certain nombre de protéines cibles des Trx de plantes ont été identifiées mais cela concerne surtout des protéines chloroplastiques (voir tableau II de l'introduction). Deux types de protéines cibles, connues pour être Trx dépendantes, ont été isolées et caractérisées lors de mon travail de thèse. Il s'agit de deux isoformes de Prx, de type II et de type Q, et de deux isoformes de MsrA, l'une étant cytosolique et l'autre plastidiale. Ces deux types d'enzymes possèdent en outre une propriété commune retrouvée dans un nombre limité d'enzymes qui est la transformation du groupement thiol des cystéines en SOH lors de la catalyse (pour revue sur les SOH voir Claiborne *et al.*, 1999 ; Claiborne *et al.*, 2001).

La caractérisation de la Prx de type II est reportée dans les articles 11 à 14, alors que celle de la Prx Q et des deux isoformes de MsrA fait l'objet des deux articles en préparation 15 et 16.



Article numéro 11 :

**Rouhier N, Gelhaye E, Sautière PE, Brun A, Laurent P, Tagu D, Gérard J, de Faÿ E, Meyer Y, Jacquot JP. (2001)**

*Isolation and characterization of a new peroxiredoxin from poplar sieve tubes that uses either glutaredoxin or thioredoxin as a proton donor.*

***Plant Physiol.* 127(3):1299-309.**

Cet article présente la mise en évidence d'une Prx de type II de peuplier (appelée à l'origine type C avant qu'une classification plus claire ne soit définie). La protéine recombinante exprimée chez *E. coli* et purifiée est une protéine monomérique qui présente de manière surprenante un doublet sur gel d'acrylamide quel que soit son état de réduction. L'activité anti-oxydante de cette enzyme a tout d'abord été vérifiée par un test de protection de plasmide en présence d'un système générateur de radicaux oxygénés. Ensuite, une activité de réduction de divers hydroperoxydes ( $H_2O_2$ , t-BOOH, CUOOH) a été établie en présence des deux systèmes réducteurs que sont les systèmes Trx et Grx. Par ailleurs, l'étude de l'expression et de la localisation de cette enzyme a été entreprise. Les transcrits codant pour la Prx de type II et la protéine ont été détectés dans les trois organes testés avec une prédominance dans les feuilles par rapport aux racines et aux tiges. Des études d'immunolocalisation sur des coupes de feuilles ont montré la présence de cette protéine dans des structures plastidiques présentes dans les tubes criblés du phloème. Cette localisation est inattendue puisque la protéine ne possède pas de peptide de transit apparent. Elle pourrait être expliquée par le fait qu'il existe une isoforme de Prx II présumée plastidiale chez *A. thaliana* et que l'homologue de cette isoforme existe certainement chez le peuplier.

# Isolation and Characterization of a New Peroxiredoxin from Poplar Sieve Tubes That Uses Either Glutaredoxin or Thioredoxin as a Proton Donor<sup>1</sup>

Nicolas Rouhier, Eric Gelhaye, Pierre-Eric Sautiere, Annick Brun, Pascal Laurent, Denis Tagu, Joelle Gerard, Elisabeth de Faÿ, Yves Meyer, and Jean-Pierre Jacquot\*

Unité Mixte de Recherche Interaction Arbres Microorganisms, Institut National de la Recherche Agronomique-Université Henri Poincaré Nancy I. Biochimie et Biologie Moléculaire Végétales, Université Henri Poincaré, 54506 Vandoeuvre cedex, France (N.R., E.G., A.B., P.L., D.T., J.G., E.d.F., J.-P.J.); Laboratoire d'Endocrinologie des Annélides Equipe Enseignement Supérieur Associé 97, Université des Sciences et Technologies de Lille, 59655 Villeneuve d'Ascq cedex, France (P.-E.S.); and Laboratoire de Physiologie et de Biologie Moléculaire des Plantes, Unité Mixte de Recherche 5545, Université de Perpignan, 66025 Perpignan cedex, France (Y.M.)

A sequence coding for a peroxiredoxin (Prx) was isolated from a xylem/phloem cDNA library from *Populus trichocarpa* and subsequently inserted into an expression plasmid yielding the construction pET-Prx. The recombinant protein was produced in *Escherichia coli* cells and purified to homogeneity with a high yield. The poplar Prx is composed of 162 residues, a property that makes it the shortest plant Prx sequence isolated so far. It was shown that the protein is monomeric and possesses two conserved cysteines (Cys). The Prx degrades hydrogen peroxide and alkyl hydroperoxides in the presence of an exogenous proton donor that can be either thioredoxin or glutaredoxin (Grx). Based on this finding, we propose that the poplar protein represents a new type of Prx that differs from the so-called 2-Cys and 1-Cys Prx, a suggestion supported by the existence of natural fusion sequences constituted of a Prx motif coupled to a Grx motif. The protein was shown to be highly expressed in sieve tubes where thioredoxin *h* and Grx are also major proteins.

Reactive oxygen, sulfur, and nitrogen intermediates can cause serious damage to macromolecules such as proteins, lipids, or nucleic acids, eventually leading to pathological processes (Halliwell and Gutteridge, 1990; Beckman and Ames, 1997; Berlett and Stadtman, 1997). Among the antioxidant defense mechanisms developed by aerobic organisms, non-enzymatic reactions dependent on glutathione, ascorbate, or  $\alpha$ -tocopherol play an important role. Alternatively, enzymatic detoxication reactions that involve catalases, superoxide dismutases, and ascorbate or glutathione peroxidases have been extensively studied and documented (Rhee et al., 1994).

A new family of antioxidative enzymes, called peroxiredoxins (Prx), recently has been characterized in all phyla (Rhee et al., 1999). These enzymes catalyze the reduction of either hydrogen peroxide ( $H_2O_2$ ) or various alkyl hydroperoxides to water and the corresponding alcohol in the presence of a hydrogen

donor, which is in turn converted to the oxidized form according to the equation:

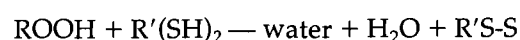

Prx associated with catalases or other peroxidases are believed to participate in signal transduction by regulating the intracellular concentration of  $H_2O_2$ , which in turn controls gene transcription and cell signaling through phosphorylation cascades (Jin et al., 1997).

Based on amino acid comparisons, Prx can be divided into two to three main groups: the so-called 2-Cys Prx (referred to as type A in this manuscript), the 1-Cys Prx (type B), and a new isotype that we will call type C. All these isoforms can be differentiated by the position of the Cys (Choi et al., 1999; Verdoucq et al., 1999; Seo et al., 2000). Prx differ from other peroxidases not only by their unique primary sequences but also by lacking prosthetic groups containing a metal ion, normally needed for the catalytic reaction to occur. Prx overcome this problem by using the conserved N terminus catalytic Cys that is converted into a sulfenic acid and regenerated via a proton donor. Site-directed mutagenesis has clearly identified this Cys residue (Cys 47 in yeast [*Saccharomyces cerevisiae*] thiol-specific antioxidant) as the catalytic residue (Chae et al., 1994a). In the case of 1-Cys Prx, the hydrogen donor remains essentially

<sup>1</sup> This work was supported by Centre National de la Recherche Scientifique grant no. PCV 98-099 and by the credit d'installation from the Ministère de l'Éducation Nationale, de la Recherche et de la Technologie.

\* Corresponding author; e-mail j2p@scbiol.uhp-nancy.fr; fax 33383912243.

Article, publication date, and citation information can be found at [www.plantphysiol.org/cgi/doi/10.1104/pp.010586](http://www.plantphysiol.org/cgi/doi/10.1104/pp.010586).

unidentified, but could be Trx for the mammalian mitochondrial enzyme (Pedrajas et al., 2000). For the 2-Cys Prx, the donor is clearly thioredoxin (Trx) and the mechanism involves another conserved Cys of Prx (Kang et al., 1998). The hydrogen donor of the new isotype is also believed to be Trx (Chae et al., 1994b). The 2-Cys Prx exhibits a dimeric structure, with two identical subunits linked by a disulfide bridge (Choi et al., 1999). Biochemical evidence indicates that 1-Cys Prx are monomeric proteins with an intramolecular disulfide in the oxidized state (Kang et al., 1998). The molecular organization of type C Prx is still largely unknown. Nevertheless, it appears that all subunits are organized in a fold similar to Trx with a central pleated  $\beta$ -sheet surrounded by  $\alpha$ -helices (Schroder and Pönting, 1998).

In mammals, Prx are associated with diverse cellular functions including apoptosis (Zhang et al., 1997; Kim et al., 2000), cell proliferation, and differentiation (Yamamoto et al., 1989; Proserpi et al., 1993). In the case of tumor necrosis factor- $\alpha$ -induced apoptosis, it was demonstrated recently that in the presence of reactive oxygen intermediates, human Trx peroxidase appears to be regulated by glutathione conjugation (Sullivan et al., 2000). This protein-glutathione mixed disulfide could then be reduced by oxidoreductases such as Trx, glutaredoxins (Grx) or protein disulfide isomerases. This regulatory mechanism of Cys oxidation reduction might prevent an irreversible oxidation of the concerned Cys into sulfonic or sulfinic acid.

As a general rule, many Prx sequences coexist in a single organism. For example, there are at least three Prx in *Escherichia coli*, five in yeast, and six isoforms characterized in mammalian cells (Zhou et al., 2000). One of the reasons explaining this multiplicity is the multiple subcellular localization of these proteins including the cytosol, peroxisomes, mitochondria, and possibly the nucleus (Stacy et al., 1999; Pedrajas et al., 2000; Zhou et al., 2000).

The systematic sequencing of Arabidopsis also indicates that there are many Prx genes in plants. It appears that the expression of some Prx genes is regulated both temporally and spatially, accounting for the high number of isoforms. In plants, the three types of Prx described above have been identified. The 1-Cys Prx, apparently encoded by a single gene, is expressed specifically in the aleurone layer and embryo of developing seeds of dicotyledonous and monocotyledonous plants (Haslekas et al., 1998; Stacy et al., 1999; Lewis et al., 2000). Its proposed function is to protect these tissues from reactive oxygen species produced during desiccation or as a by-product of respiration during imbibition of seeds. Moreover, there is indirect evidence suggesting that Prx are involved in maintenance of dormancy (Lewis et al., 2000). Apparently in plants, the 2-Cys Prx characterized so far are nuclear encoded, but localized in the chloroplasts (Baier and Dietz, 1997). The

chloroplastic 2-Cys Prx belong to a multigenic family and seem to be expressed in most plant tissues but the roots (Cheong et al., 1999). It is assumed to detoxify products of chloroplastic electron transport (Baier and Dietz, 1999). A recent report indicates that antisense plants suppressed for 2-Cys Prx compensate by overexpressing ascorbate peroxidase and dehydroascorbate reductase, suggesting that a subtle equilibrium exists between diverse antioxidant enzymes in chloroplasts (Baier et al., 2000).

Prx of the C type have been isolated recently from a flower bud cDNA library of *Brassica rapa* (Choi et al., 1999) and also from Arabidopsis (Verdoucq et al., 1999). In a very classic assay, the Prx from Chinese cabbage (*Brassica campestris* L. subsp. *pekinensis*) protects Gln synthetase from oxidation by radicals generated by the Fenton reaction. Both the Arabidopsis and *B. rapa* enzymes have been described to reduce  $H_2O_2$  in the presence of NADPH, Trx reductase, and Trx. We describe here the isolation and characterization of a Prx of the type C from poplar (*Populus trichocarpa*) phloem and show that this protein is bifunctional, i.e. it can use either Trx or Grx as a hydrogen donor. This is discussed in the light of existing homologous prokaryotic sequences that contain a Grx motif fused to type C Prx. The protein was shown to be present in the plant and highly expressed in the sieve tubes of the phloem, which also contains high amounts of Trx and Grx.

## RESULTS

### Sequence Analysis and Cloning

Based on two overlapping expressed sequence tags (ESTs; AI163857 and AI162101) of respectively 458 and 553 nucleotides, a putative full-length sequence coding for a poplar Prx has been reconstituted. The corresponding cDNA sequence has been cloned by PCR and inserted into the expression plasmid pET-3d, yielding the construction pET-Prx. The open reading frame consists of 489 nucleotides coding for a polypeptide of 162 amino acids. Figure 1 shows an amino acid sequence comparison that includes plant Prx of the three types (A, B, and C). The sequence isolated in this study is strongly associated with the type C Prx from plants. It is clear that all type A plant Prx possess a N terminus extension of about 75 amino acids that presumably codes for a chloroplastic transit peptide as described in Baier and Dietz (1999). In general, Prx of the B and C type do not possess similar extensions and are thus probably not routed to mitochondria, chloroplasts, or to the vacuolar and extracellular compartments. A remarkable feature of the poplar sequence and all type C plant Prx is that they are all considerably shorter on the C-terminal end (type A and B show about 36 and 56 amino acids extensions, respectively). As a consequence, the type C sequences are among the shortest isolated for a Prx so far. The poplar Prx isolated in

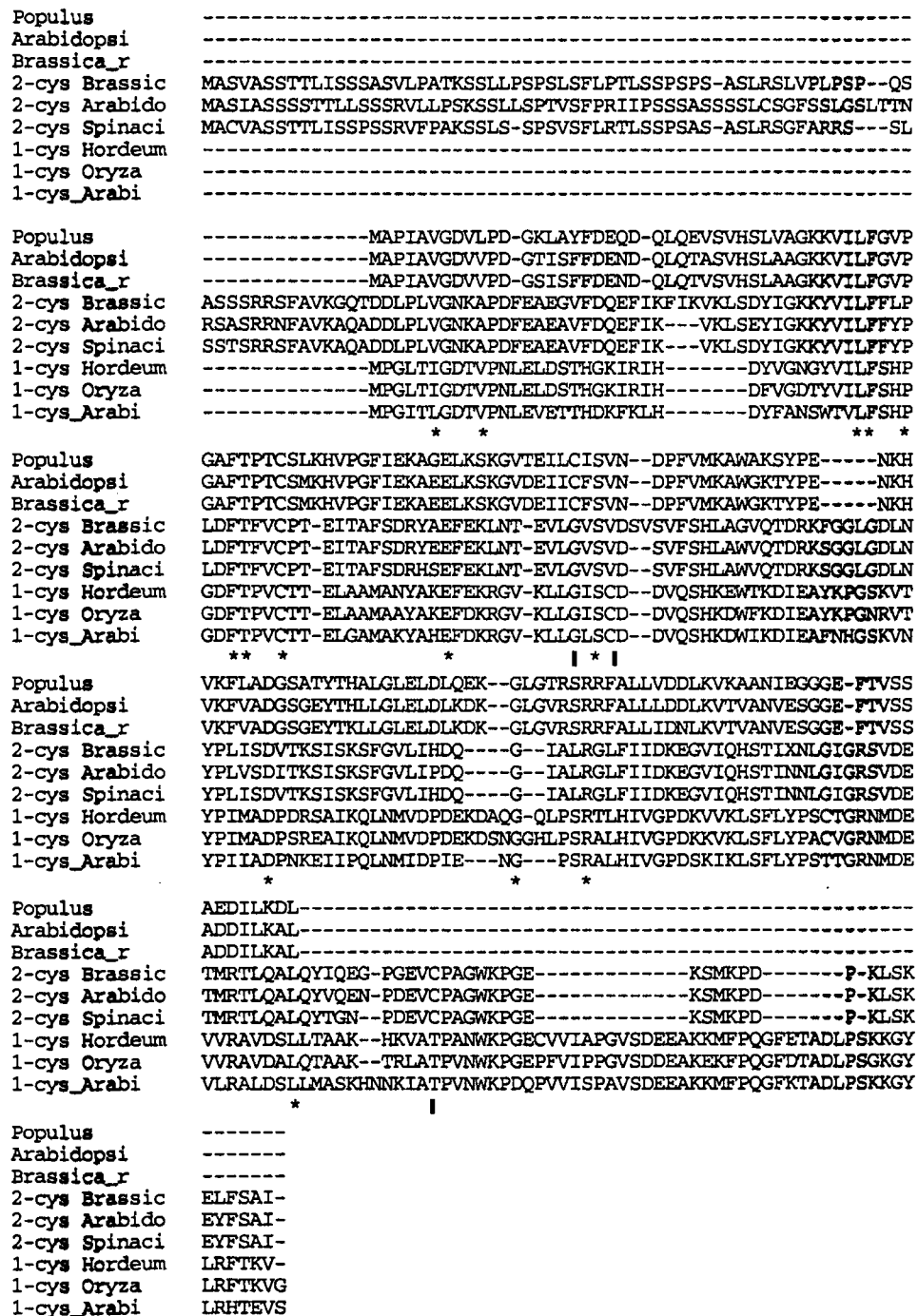

Figure 1. Amino acid sequence alignment of plant Prx. The first three sequences belong to type C Prx, the three following sequences are 2-Cys Prx (type A), and the last three are 1-Cys Prx (type B). This alignment was performed using the Clustal W program, and the accession numbers for these sequences are: Arabidopsis, AAD28242; *B. rapa*, AAD33602; 2-Cys *B. rapa*, AF052202; 2-Cys Arabidopsis, BAB08951; 2-Cys *Spinacia oleracea*, O24364; 1-Cys *Hordeum vulgare*, CAA65387; 1-Cys *Oryza sativa*, BAA09947; and 1-Cys Arabidopsis, Y12089. Asterisk, Indicates strict homologies between all the sequences and conserved Cys within a Prx subtype.

this work displays strict identity of 80% to the Arabidopsis and *Brassica rapa*-type C Prx sequences. On the other hand, the identities are much lower compared with type A or B Prx (10%–15% and 13%–19%, respectively). Type A and B are similarly loosely

related (21%–25% identity). Overall, plant Prx of the type A exhibit 77% to 85% identity, those of type B exhibit 68% to 84% identity, and those of type C exhibit 80% to 96% identity. At first, the absence of an N-terminal extension and of identified signals as Ser-

Rouhier et al.

Lys-Leu for the peroxisomes suggest that the subcellular localization of the poplar Prx might be the cytosol, and the interrogation of the PSORT site (<http://psort.nibb.ac.jp/form.html>) supports this proposal. A very characteristic feature of all the Prx sequences is that one Cys residue (Cys 51 in the poplar enzyme) is strictly conserved with the surrounding consensus sequence: P[G/L][A/D]FT[P/F][T/V]C[S/P/T]. Site-directed mutagenesis has shown that this residue is the catalytic one in all Prx characterized so far (Chae et al., 1994a). The poplar sequence isolated in this work shows only one additional Cys (Cys 76), which is strictly conserved among type C Prx.

#### Expression of the Recombinant Protein, Purification, and Physical Characteristics

When the *E. coli* BL21 (DE3) strain was cotransformed by the plasmids pET-Prx and pSBET, a huge overexpression of the enzyme was observed, the recombinant Prx representing more than 50% of the total protein content (data not shown). This allowed us to purify the protein with a very high yield using two simple chromatographic steps consisting of an ACA 44 gel filtration column followed by a DEAE-Sephacel ion exchange. Nearly 40 mg protein was obtained per liter culture with a very high purity, based on a calculated molar extinction coefficient of  $10,930 \text{ M}^{-1} \text{ cm}^{-1}$  (see Fig. 2). After staining with Coomassie Blue, the purified protein clearly shows a doublet band with an apparent molecular mass of about 18 kDa, a value in close agreement with the predicted mass of the polypeptide (17,408 D). The origin of the polypeptide doublet is not fully understood, but it was observed when lysing whole bacterial cells that a similar doublet is already present, strongly suggesting that this property is not an artifact due to proteolysis during the protein purification process. Nevertheless, an N terminus amino acid analysis of the recombinant protein indicated a

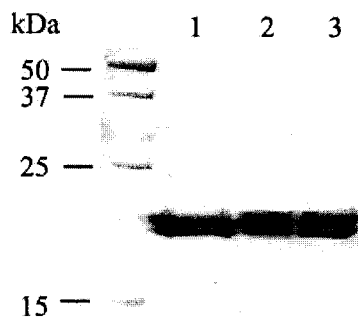

**Figure 2.** Size determination and purity of recombinant poplar Prx. The size marker used is Precision Protein Standards, unstained from Bio-Rad (Hercules, CA). Each lane contains about 3  $\mu\text{g}$  of Prx. Lane 1, SDS and  $\beta$ -mercaptoethanol; lane 2, SDS alone; lane 3, SDS and dithiothreitol (DTT).

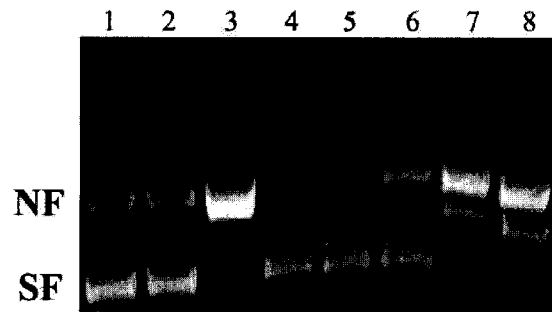

**Figure 3.** Prx-dependent inactivation of DNA cleavage by MCO. Plasmid pLBR19 was added in each reaction mixture after 40 min. Lane 1, pLBR19 alone; lane 2, DTT alone; lane 3, DTT +  $\text{FeCl}_3$ ; lanes 4 through 6, DTT +  $\text{FeCl}_3$  + various amounts of Prx (10, 20, and 40  $\mu\text{M}$ ); lane 7, DTT +  $\text{FeCl}_3$  + bovine serum albumin (BSA; 20  $\mu\text{M}$ ); lane 8, ascorbate +  $\text{FeCl}_3$ . Nicked form (NF) and supercoiled form (SF) of pLBR19 are indicated on the left.

clipping of the N terminus with the superimposition of the sequences MAPIAV, APIAV, and PIAV, the MAPIAV sequence being more prevalent, accounting for more than 50% of the whole protein population. A similar doublet has been observed with various Prx and Kang et al. (1998) have shown that this doublet can be erased on type B Prx when the samples are treated with a strong reductant as DTT. However, Figure 2 shows that even when the samples are treated with a strong reductant (DTT instead of  $\beta$ -mercaptoethanol), at high temperature in the presence of SDS, a double component is always observed. Extraction of poplar Prx from the bacterial cells in the presence of 5 mM DTT and purification in the presence of 1 mM DTT also did not affect the SDS-PAGE pattern, suggesting that the oxidation of the highly conserved Cys (Cys 51) was not the cause of this behavior. Even when the protein was prepared in the absence of a reductant, it was found to be essentially in the reduced state. This was estimated by titrating the recombinant enzyme with 5,5'-dithiobis-nitrobenzoic acid (DTNB). In the native state or in the denatured state (in the presence of 1% [w/v] SDS), 2 mol thiol groups were observed per mole enzyme, suggesting that the enzyme is fully reduced and that both thiols are accessible and not buried. The addition of concentrations of  $\text{H}_2\text{O}_2$ , ranging from 100  $\mu\text{M}$  to 1 mM, resulted in the disappearance of 1.5 mol SH per mole enzyme. Thus, it is likely that the addition of the oxidizing substrate fully oxidizes the presumed catalytic Cys and partially Cys 76.

The oligomeric nature of Prx of the C type is not well documented in the literature so far. On the other hand, it has been proposed that Prx of the A type are dimers of identical subunits linked by a disulfide bridge. Treating the recombinant enzyme with SDS in the absence of a reductant (either  $\beta$ -mercaptoethanol or DTT) clearly indicates that such a hypothesis can be ruled out for the poplar enzyme because the protein always migrates as a monomer (data not shown). When analyzed on

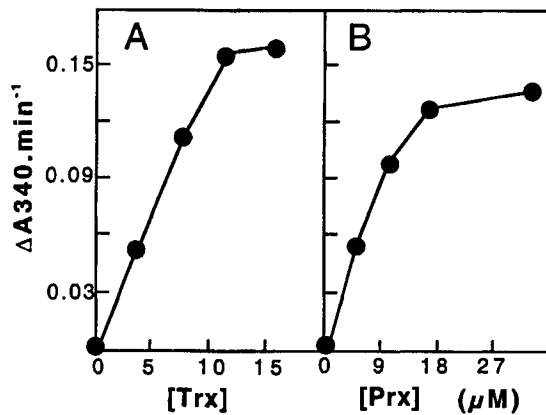

**Figure 4.** Trx and Prx dependency of  $\text{H}_2\text{O}_2$  reduction. The concentrations of the other components are as follows: 150  $\mu\text{M}$  NADPH, 1.6  $\mu\text{M}$  NADPH Trx reductase (NTR), and 100  $\mu\text{M}$   $\text{H}_2\text{O}_2$ . A, Prx concentration is 5  $\mu\text{M}$ ; B, Trx concentration is 4  $\mu\text{M}$ .

ACA44 gel filtration, the poplar Prx also behaved as a monomer (data not shown), suggesting that type C Prx is monomeric.

#### Catalytic Properties of Type C Poplar Prx

One of the most widely used tests for the detection of Prx activity is the protection of plasmids in the presence of a thiol metal-catalyzed oxidation (MCO) generating system (generally DTT and reduced Fe; Fig. 3). Although the strong oxidizing agents generated by the MCO system are able to destroy the plasmid, the addition of recombinant Prx clearly has a protective effect that cannot be reproduced by the addition of similar amounts of an unrelated protein, BSA. When DTT was replaced by reduced ascorbate, the plasmid was not protected and degraded, confirming the need for a thiol as a reductant of Prx.

The poplar Prx is able to reduce  $\text{H}_2\text{O}_2$  in the presence of external hydrogen donors, Trx (Fig. 4) or Grx (Fig. 5). As shown in Table I, the Prx can use reduced poplar Trx *h* as a proton donor generated by the addition of NADPH and NTR. Omitting either the NTR or the Trx *h* components as well as the substrate  $\text{H}_2\text{O}_2$  results in a complete loss of the NADPH oxidizing activity. Table I also shows that the C type poplar Prx can alternatively use reduced poplar Grx as a proton donor to carry out its catalytic reaction. In this case, the generating system is composed of NADPH, GR, glutathione, and Grx. Because reduced glutathione directly reduces  $\text{H}_2\text{O}_2$ , a background activity is observed when either Grx or Prx are omitted. Nevertheless, a full activity is only observed when all the components of the GSH/Grx chain are supplied, strongly suggesting that Grx can serve as an alternate proton donor for type C Prx.

Figure 4A shows the Prx linked reduction of  $\text{H}_2\text{O}_2$  in the presence of increasing Trx *h* concentrations. The reaction rate increases as a function of Trx concentrations and saturates at about 10  $\mu\text{M}$  (Fig. 4A).

The reaction rate was also examined as a function of the Prx concentration (Fig. 4B). As expected, the catalytic activity goes up with increasing Prx concentrations in the range 0 to 15  $\mu\text{M}$ . The rate of the reaction was also estimated as a function of the Grx concentrations when reduced GSH was the donor (Fig. 5). Similar to what was observed with Trx, the reaction rate increases as a function of the Grx concentration and saturates at about 30  $\mu\text{M}$  (Fig. 5A). With glutathione and Grx as electron donor, the reaction rate increased with increasing Prx concentrations in the range 0 to 80  $\mu\text{M}$  (Fig. 5B).

The capacity of recombinant poplar Prx to reduce various other peroxides has also been evaluated. Table II shows that besides  $\text{H}_2\text{O}_2$ , cumene hydroperoxide and *tert*-butyl hydroperoxide can also be used by this enzyme, with similar efficiency. However, cumene hydroperoxide is clearly detrimental to proteins of the Trx system because the activity recorded drops to about 35% of those obtained with either  $\text{H}_2\text{O}_2$  or *tert*-butyl hydroperoxide, whereas this activity remains nearly constant with the Grx system.

#### Expression and Localization in Planta

We have also generated evidence that the type C Prx gene is efficiently transcribed and translated in planta. Figure 6A shows the results of a northern experiment made with RNAs isolated from three different poplar organs: leaves, stems, and roots. A single transcript of about 1 kb was detected in all organs, and the level of transcription was high in leaves (lane L), lower in roots (lane R), and weak in stems (lane S). The use of specific polyclonal antibodies allowed us to detect the presence of the Prx polypeptide in all organs as well (Fig. 6B). The western-blot experiment matches the results of the northern-blot experiment, with higher expression in leaves and

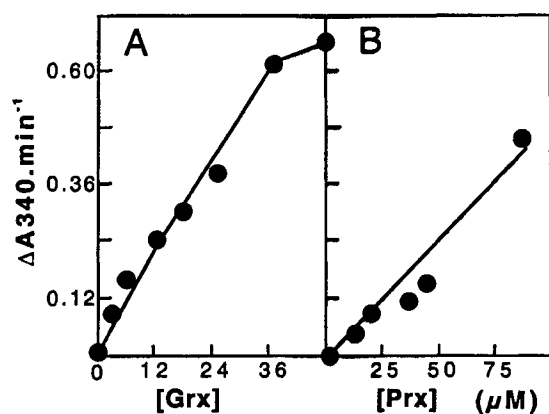

**Figure 5.** Grx and Prx dependency of  $\text{H}_2\text{O}_2$  reduction. The concentrations/amounts of the other components are as follows: 150  $\mu\text{M}$  NADPH, 0.5 units glutathione reductase (GR), 1 mM GSH, and 100  $\mu\text{M}$   $\text{H}_2\text{O}_2$ . A, Prx concentration is 40  $\mu\text{M}$ ; B, Grx concentration is 12  $\mu\text{M}$ . The background activities due to reduced glutathione alone (about 0.1  $\Delta$  OD/min) have been subtracted.

**Table I.** Proton donor requirements for the peroxiredoxin-linked reduction of  $H_2O_2$ 

All reactions were carried out at 30°C in a total volume of 500  $\mu$ L and followed spectrophotometrically using a Cary 50 spectrophotometer (Varian Mulgrave, Victoria, Australia). The results are expressed in  $\Delta A_{340}$  per minute. The concentrations/amounts of the various components were as follows: A, 1.6  $\mu$ M NTR, 15  $\mu$ M Trx *h*, 17  $\mu$ M Prx, 100  $\mu$ M  $H_2O_2$  and B, 0.5 units GR, 1 mM GSH, 50  $\mu$ M Grx, 43  $\mu$ M Prx; 100  $\mu$ M  $H_2O_2$ .

A		B	
Complete	0.522	Complete	0.662
-NTR	0.006	-GR	0.000
-Trx <i>h</i>	0.005	-GSH	0.000
-Prx	0.004	-Grx	0.095
- $H_2O_2$	0.016	-Prx	0.095
		- $H_2O_2$	0.011

roots. It was estimated that there is approximately 500 ng Prx mg protein<sup>-1</sup> in leaves based on a standard curve established with increasing amounts of the recombinant protein (data not shown). A single polypeptide was detected in plant extracts with a size identical to the recombinant protein. Again, this indicates that there is no cleavage of a signal sequence in the protein. Nevertheless, immunolocalization experiments in leaves indicate the presence of large amounts of type C Prx in the sieve tubes of the phloem. The gold particle labeling was extremely specific and essentially restricted to plastid-like structures present in these cells (Fig. 7).

## DISCUSSION

The Prx sequence isolated here is neither a so-called 2-Cys Prx (referred to in this work as type A), nor a 1-Cys Prx (referred here as type B). The poplar Prx is the shortest among the many isotypes characterized so far (only 162 amino acids). It lacks especially a C-terminal extension consistently present in isotypes A and B and there is no N-terminal extension. The presence in all ESTs of a stop codon in frame 9 triplets upstream of the initiation codon precludes the existence of a transit peptide in this protein. Despite the apparent absence of a signal sequence, the protein was shown by immunochimistry to be located in plastids of the sieve elements of the phloem. Thus, either there is a signal internal to the sequence or the protein is transported through the vesicular pathway from the companion cell via the branched plasmodesmata. It is interesting that both Trx and Grx are major soluble protein components of the phloem sap (Szederkenyi et al., 1997; Ishiwatari et al., 1998). This has prompted speculation that both proteins are involved in redox based regulation in phloem cells. It is clear that the Prx isolated here could participate to such a regulation because it uses both Trx and Grx as a proton donor. It is interesting that it has been proposed that upon injury, the sieve element plastids disintegrate and

release their protein content at the level of the sieve plate (Knoblauch and van Bel, 1998). Because type C Prx is specifically located in those structures, it is tempting to speculate that it should be involved in the response to oxidative stress generated in such conditions.

A high expression of Prx was obtained by cotransformation with the plasmid pSBET and the protein could then be purified with a very high yield. The native enzyme is monomeric in solution and its two Cys residues are in the reduced form, irrespective of its mode of purification (inclusion of a reductant as DTT or not). It is interesting that type A Prx are reported to be dimeric enzymes with a disulfide bridge connecting the catalytic Cys of one subunit and another Cys of the other subunit. Because this additional Cys is in the C terminus extension, a similar organization cannot apply to the type C Prx described in this work.

We propose that the short length of the sequence is a first criterion of a type C Prx. Other criteria are the presence of an additional invariant Cys at position 76 and the capacity to use either Trx or Grx as a proton donor for the reaction. The poplar enzyme reduces alkyl hydroperoxides, and especially  $H_2O_2$ , in the presence of an exogenous proton donor. This was demonstrated both kinetically, following the NADPH oxidation linked to the catalytic process, and by the observation that externally added  $H_2O_2$  is able to oxidize critical Cys residues, even at low concentrations. The capacity to reduce  $H_2O_2$  was also confirmed with a widely used plasmid protection assay. The biochemical data suggest that the poplar Prx is able to use either Trx or Grx as proton donors, a result that has not been reported before (Fig. 8). This raises the question of the identity of the physiological proton donor of this new type C Prx.

The biochemical data presented here do not permit us to determine the identity of the physiological proton donor in plants because both systems (Trx and Grx) display similar efficiencies. A further complication is the high number of Trx *h* variants in plants (Buchanan et al., 1994; Rivera-Madrid et al., 1995), because the different isoforms could display varying affinities toward type C Prx. We could not test all isoforms as proton donors at this point, but could

**Table II.** Comparison of various alkylhydroperoxides as substrates of poplar Prx

Reactions are performed at 30°C in 50 mM phosphate buffer, pH 7, with 150  $\mu$ M NADPH, 100  $\mu$ M substrates, and in the presence of 1.6  $\mu$ M NTR, 15  $\mu$ M Trx, and 25  $\mu$ M Prx for the Trx system and 0.5 units of GR, 1 mM GSH, 12.5  $\mu$ M Grx, and 25  $\mu$ M Prx for the Grx system. Reactions were started after 1 min by adding substrates.

Substrate	Proton Donor	
	Trx system	Grx system
$H_2O_2$	0.453	0.311
Cumene hydroperoxide	0.174	0.278
<i>tert</i> -butyl hydroperoxide	0.409	0.256

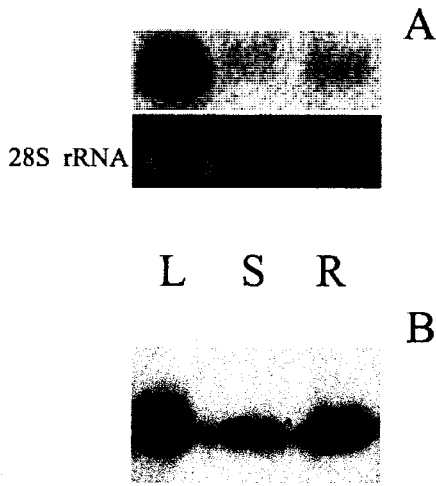

**Figure 6.** : Detection of Prx mRNA and polypeptide in planta. L, Leaves, S, stems; R, roots. A, Northern-blot analysis: as a control, 28S rRNA stained by Radiant Red RNA gel stain from Bio-Rad before blotting is shown. B, Western-blot analysis with purified anti-Prx antibody.

observe that the distant *Chlamydomonas reinhardtii* Trx *h* shows similar reactivity to the poplar Trx *h* used in this work (data not shown). This could be an indication that there should not be a high specificity between the Trx *h* isoforms versus type C Prx. In an earlier work, using a Trx modified by site-directed mutagenesis, a yeast Prx (YLR109) has been identified as an *in vivo* target of Trx (Verdoucq et al., 1999). It should be stressed, however, that YLR109 presents lower homologies to type C Prx because it possesses several sequence insertions and lacks the additional conserved Cys typical of all plant sequences. As a consequence, it is not clear whether this result can be extended to the type C plant Prx exemplified by the sequence studied in this work.

A very interesting piece of information about the nature of the proton donor can be obtained from sequences available in the nucleotide data bank. Three of those sequences (*Hemophilus influenzae*, *Neisseria meningitidis*, and *Vibrio cholerae* with accession nos. AAC22230, CAB94403, and AE004330, respectively) exhibit a natural fusion between a Prx motif present in the N terminus of the sequence and a Grx motif that constitutes the C terminus of the sequence. The N terminus displays strong homology (over 50%) with the poplar Prx sequence, with no sign of a N terminus extension. In addition, two of these se-



**Figure 7.** Electron micrographs of poplar sieve elements. A, One sieve element (SE) containing sieve element plastids (PI) and parietal P proteins (PP) shown with companion cell (CC). B, Prx labeling in sieve element plastids.



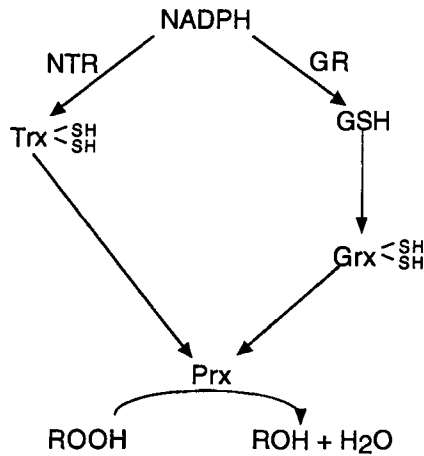

Figure 8. The two pathways involved in type C Prx catalysis.

quences (*V. cholerae* and *N. meningitidis*) possess the conserved additional Cys (equivalent to Cys 76). This definitely classifies those sequences as a putative ancestor of type C Prx. The existence of these prokaryotic sequences strongly suggests that a Grx could serve as a physiological proton donor to type C Prx, in a manner analogous to the natural fusion protein that exists between Trx reductase and Trx in *Mycobacterium leprae* (Wieles et al., 1995). Moreover, recent analyses indicate that in prokaryotes, gene fusion events could reasonably indicate a functional association of these proteins (Enright et al., 1999; Marcotte et al., 1999).

## MATERIALS AND METHODS

### Cloning of the cDNA Sequences, Expression in *Escherichia coli* of the Recombinant Proteins, and Purification Procedures

The expression and purification of *Chlamydomonas reinhardtii* and poplar (*Populus trichocarpa*  $\times$  *deltoides*) Trx *h* as well as of Arabidopsis NTR have been described already (Jacquot et al., 1994; Stein et al., 1995; Behm and Jacquot., 2000). The procedure for the overexpression and purification of Grx will be described in a separate paper.

Several ESTs corresponding to poplar Prx were identified in GenBank (<http://www.ncbi.nlm.nih.gov:80/entrez/query.fcgi?db=Nucleotide>) using the program Advanced Blast 2.0 (<http://www.ncbi.nlm.nih.gov:80/BLAST/>). Two primers were designed to amplify the full-length cDNA by PCR using as a template a phage cDNA xylem/phloem library from poplar provided by Drs. Wout Boerjan and Hugo Meyermans (University of Gent, Belgium). The forward oligonucleotide (GGGGCCATGGC-CCCATTGCTGTTGGT) contains an *Nco*I restriction site (underlined) with the initial ATG followed by the 5' sequence of the open reading frame, and the reverse primer (GGGGGATCCCTCAAAGATCCTTGAGATATCC) contains a *Bam*HI restriction site followed by sequences complementary to the stop codon and matching the 3' end of the open reading frame. The fragment coding for Prx was

amplified by PCR, using 2.5  $\mu$ L of cDNA library as a template. The cDNA library was first denatured by an initial step of 10 min at 95°C. *Taq* polymerase was then added and 35 cycles of amplification were performed (1 min at 95°C, 2 min at 47°C, and 3 min at 72°C), followed by a final extension step of 10 min. Overall, the PCR reaction (100  $\mu$ L) contained 1 unit of Goldstar DNA polymerase, 200 nM of each primer, 2 mM MgCl<sub>2</sub>, and 160  $\mu$ M deoxyribonucleotide triphosphate).

The PCR product of about 500 bp was then purified, digested, and cloned into the pET-3d vector to generate the construction pET-Prx that was used to transform BL21(DE3). An initial small-scale expression gave very poor yields, presumably because of the existence of codons poorly adapted to *E. coli* translation machinery. It is well known that several triplets are not frequently used in *E. coli*, presumably because of low amounts of the corresponding tRNAs (Makrides, 1996). A thorough examination of the poplar Prx sequence indicates that a tandem of AGG triplets coding for the doublet R128-R129 should be extremely unfavorable for a high yield expression. In accordance, the *E. coli* BL21 (DE3) strain was cotransformed by pET-Prx and by the plasmid pSBET that encodes the tRNA needed to recognize the AGG and AGA triplets (Schenk et al., 1995). The *E. coli* BL21(DE3) strain, cotransformed with pSBET (Schenk et al., 1995), was transformed by electroporation by pET-Prx. One ampicillin- and kanamycin-resistant clone was amplified up to 5 L in Luria-Bertani medium at 25°C and induced during 4 h with 100  $\mu$ M isopropyl- $\beta$ -D-thiogalactopyranoside. The bacterial cells were collected by centrifugation (5,000g, 15 min) and resuspended in TE buffer (30 mM Tris-HCl, pH8, and 1 mM EDTA) to a final volume of about 80 mL. The cell suspension was sonicated on ice by 30-mL batches for 3 min using an Ultrasonic XL Sonicator with an output of 4 and a duty cycle of 50. Solid ammonium sulfate was then added and the proteins precipitating between 40% and 80% (w/v) of the saturation were collected by centrifugation (30,000g, 20 min). The protein pellet was then resuspended in about 20 mL of TE. The purification of recombinant poplar Prx requires two chromatographic steps. First, the sample was loaded onto an ACA44 column (70  $\times$  5 cm) and then the fractions containing the recombinant protein were pooled and laid onto a DEAE Sepharose fast-flow column (10  $\times$  2.5 cm). The protein was eluted with a 0 to 0.4 M NaCl gradient in buffer TE (250–250 mL), and then concentrated and dialyzed against TE buffer on a cell (Amicon, Beverly, MA) equipped with a YM10 membrane. The protein was kept frozen at  $-20^{\circ}\text{C}$  and stored as 50- $\mu$ L aliquots at a concentration of about 30 mg mL<sup>-1</sup>.

### In Vitro Peroxidase Assays

The reduction of H<sub>2</sub>O<sub>2</sub> or alkyl hydroperoxides was first estimated indirectly by measuring NADPH oxidation at 340 nm. It is based on the property that Prx uses a hydrogen donor to carry out catalysis (most often reduced Trx generated via NADPH and NTR), but also in this study, reduced Grx in the presence of glutathione, which is itself maintained reduced by NADPH and GR.

The reaction mixture (500  $\mu$ L) for the Trx-dependent assay was as follows: 50 mM Na-K phosphate buffer, pH 7.0; 150  $\mu$ M NADPH; 0 to 50  $\mu$ M poplar or *C. reinhardtii* Trx *h*; 0 to 50  $\mu$ M Prx; and 1.5  $\mu$ M Arabidopsis Trx reductase. The reaction was initiated by adding 1 mM H<sub>2</sub>O<sub>2</sub> and the NADPH oxidation was followed spectrophotometrically at 340 nm using a Cary 50 apparatus at 30°C.

When Grx was tested as the proton donor, the reaction medium had the following composition: 50 mM Na-K phosphate buffer, pH 7.0; 150  $\mu$ M NADPH; 1 mM reduced glutathione; 0.5 units GR; 0 to 50  $\mu$ M Grx; and 0 to 80  $\mu$ M Prx. As described above, the reaction was carried out in 500  $\mu$ L, initiated with H<sub>2</sub>O<sub>2</sub>, and its rate followed spectrophotometrically at 340 nm.

A second possible test is the protection of plasmids against radicals generated by MCO. H<sub>2</sub>O<sub>2</sub> can be formed by a reaction occurring between DTT, Fe<sup>3+</sup>, and O<sub>2</sub>, and then transformed into hydroxyl radical by the Fenton reaction (Halliwell and Gutteridge, 1990). These radicals are able to damage nucleic acids or inactivate enzymes as Gln synthetase.

Plasmid pLBR19 was used to measure the capacity of Prx to eliminate H<sub>2</sub>O<sub>2</sub> before its transformation in radicals. A reaction mixture of 20  $\mu$ L includes 3.3  $\mu$ M FeCl<sub>3</sub>, 10 mM DTT for the thiol MCO system, or 10 mM ascorbate for the non-thiol MCO system, different Prx concentrations (10–40  $\mu$ M), or 20  $\mu$ M BSA, in 50 mM HEPES [4-(2-hydroxyethyl)-1-piperazineethanesulfonic acid]-[NaOH], pH 7.2. The reaction was initiated by incubating the mixture for 40 min before adding about 1  $\mu$ g of plasmid for 7 h at 37°C. The plasmid degradation was evaluated on 1% (w/v) agarose gel after staining with ethidium bromide (Sambrook et al., 1989).

### Thiol Content Titration

The free thiol content of recombinant poplar Prx was estimated using DTNB as described by Jacquot et al. (1984). One milligram of Prx dissolved in 1 mL of Tris-HCl (100 mM, pH 8.0) was reacted with 10  $\mu$ L of 20 mM DTNB in the presence of various H<sub>2</sub>O<sub>2</sub> concentrations (ranging from 100  $\mu$ M to 1 mM). An assay was performed in the presence of 1% (w/v) SDS to denature the protein and estimate whether it contains buried thiol groups. The cleavage of DTNB to TNB<sup>-</sup> was followed by measuring the A<sub>412</sub> after 30 min reaction in the dark, and the thiol content was determined using a molar extinction coefficient of 13,600 M<sup>-1</sup> cm<sup>-1</sup> at 412 nm.

### Protein Extraction from Poplar Tissues

Four-hundred milligrams of 2-month-old poplar leaves, stems, and roots was used for protein extraction. Tissues were ground into powder in the presence of liquid nitrogen and suspended in the extraction buffer (50 mM Tris-HCl, pH 7.5; 14 mM phenylmethylsulfonyl fluoride; and 0.05% [v/v]  $\beta$ -mercaptoethanol). Soluble proteins were obtained in the supernatant by two successive centrifugation steps (14,000g, 10 min) and then precipitated in the presence of

acetone (4 volumes). Proteins were pelleted by centrifugation, the pellet was then washed by a novel centrifugation step in the presence of acetone, and dried after eliminating the supernatant. Proteins were resuspended in a solubilization buffer composed of 125 mM Tris HCl, pH 6.8; 20% (v/v) glycerol; 2% (w/v) SDS; 5% (v/v)  $\beta$ -mercaptoethanol; and 0.05% (w/v) bromophenol blue. Protein concentrations in the extracts were determined by the Bradford reaction as described in the Bio-Rad kit.

### Antibody Purification

The antibodies have been purified from the serum by immuno-adsorption on a Prx-Sepharose column generated by coupling 35 mg of Prx to 2.5 g of CNBr Sepharose gel (Amersham Pharmacia Biotech, Uppsala). Fractions of 4 mL of the rabbit serum were applied onto the column (1  $\times$  5 cm) and the antibodies were allowed to react with the matrix for 30 min. After washing the column with TE buffer, antibodies were eluted with 50 mM acetic acid in fractions of 1 mL in tubes containing 200  $\mu$ L of 1 M Tris-HCl, pH 8. Fractions containing the antibodies were pooled and dialyzed against TE buffer.

### SDS-PAGE and Western Blotting

Proteins from poplar tissues (10  $\mu$ g) were separated by 14% (w/v) SDS-PAGE following the procedure of Laemmli (1970) and transferred onto a polyvinylidene difluoride membrane during the night in the presence of transfer buffer (25 mM Tris, 192 mM Gly, and 20% [v/v] ethanol). Blocking of the membrane was achieved at room temperature during 4 h with the blocking buffer (20 mM Tris-HCl, pH 7.5; 500 mM NaCl; 0.05% [w/v] milk powder; and 0.05% [v/v] Tween 20). The membrane was then incubated with purified anti-Prx antibodies (equivalent to 1.10<sup>-3</sup> OD at 280 nm) in 15 mL of blocking buffer during at least 2 h, and extensively washed before reaction with anti-rabbit secondary antibodies provided in the Immune Star Goat Anti Rabbit Detection Kit from Bio-Rad. The bioluminescence reaction was done according to the instructions of the manufacturer.

### RNA Extraction and Northern Blotting

Total RNA was extracted from 100 mg of leaves, stems, and roots from 2-month-old poplar grown in hydroponic medium, with the RNeasy Plant Mini Kit (Qiagen USA, Valencia, CA) with addition of polyethylene glycol 8000 to the extraction buffer at a concentration of 20 mg mL<sup>-1</sup>. Ten micrograms of total RNA was separated and blotted by capillarity onto a nylon membrane from Amersham Pharmacia Biotech. The probe, consisting of about 100 ng of a PCR fragment (identical to the Prx fragment cloned), was labeled with <sup>32</sup>P dATP following the instructions provided in the kit Prime a Gene Labeling System (Promega, Madison, WI). The probe was then purified with the QIAquick Nucleotides Removal Kit from Qiagen, and was estimated to contain 30 million cpm. Hybridization was performed at

Rouhier et al.

42°C in the presence of 5× SSPE and 0.5% (w/v) SDS, and washing at 65°C with a solution of 2× SSPE and 0.1% (w/v) SDS.

### Immunolocalization Procedures

Samples were dissected from young poplar leaves in a drop of fixation solution and then fixed by immersion for 3 h at 4°C in 4% (w/v) paraformaldehyde and 0.5% (v/v) glutaraldehyde in 0.1 M cacodylate buffer, pH 7.4. Leaf samples were subsequently rinsed in 0.1 M of the above buffer, treated with 2% (w/v) OsO<sub>4</sub>, dehydrated in a series of alcohol and propylene oxide, embedded in Durcupan, and finally polymerized at 56° for 48 h.

Ultrathin sections were successively floated for 15 min in a 0.05 M Gly, 0.05 M Tris-phosphate-buffered saline (TPBS) solution, 30 min on a blocking solution of 1% (w/v) BSA in TPBS (TPBS/BSA), and then treated for 2 h with the purified rabbit Prx-antibodies (diluted 1:100 [v/v] in TPBS/BSA). This step was omitted in the controls. After washing, sections were incubated for 2 h in a solution of 0.05 M Tris-HCl buffer containing 0.05% (w/v) polyethylene glycol with gold-labeled goat anti-rabbit IgG (10 nm, dilution 1:20 [v/v], Sigma, St. Louis). Sections were then rinsed, dried, and stained with uranyl acetate and lead citrate.

### ACKNOWLEDGMENTS

The authors would like to thank Matthieu Behm for initial cloning experiments, Eliane Keryer for DNA sequencing, Marine Wasniewski for invaluable help with the northern experiments, Arnaud Javelle for helpful discussions, and Dr. Hugo Meyermans for providing the poplar cDNA library.

Received July 2, 2001; returned for revision July 10, 2001; accepted August 15, 2001.

### LITERATURE CITED

- Baier M, Dietz KJ (1997) The plant 2-Cys peroxiredoxin BAS1 is a nuclear-encoded chloroplast protein: its expressional regulation, phylogenetic origin, and implications for its specific physiological function in plants. *Plant J* 12: 179–190
- Baier M, Dietz KJ (1999) Protective function of chloroplast 2-cysteine peroxiredoxin in photosynthesis: evidence from transgenic *Arabidopsis*. *Plant Physiol* 119: 1407–1414
- Baier M, Noctor G, Foyer CH, Dietz KJ (2000) Antisense suppression of 2-cysteine peroxiredoxin in *Arabidopsis* specifically enhances the activities and expression of enzymes associated with ascorbate metabolism but not glutathione metabolism. *Plant Physiol* 124: 823–832
- Beckman KB, Ames BN (1997) Oxidative decay of DNA. *J Biol Chem* 272: 19633–19636
- Behm M, Jacquot JP (2000) Isolation and characterization of thioredoxin h from poplar xylem. *Plant Physiol Biochem* 38: 363–369
- Berlett BS, Stadtman ER (1997) Protein oxidation in aging, disease, and oxidative stress. *J Biol Chem* 272: 20313–20316
- Buchanan BB, Schürmann P, Decottignies P, Lozano RM (1994) Thioredoxin: a multifunctional regulatory protein with a bright future in technology and medicine. *Arch Biochem Biophys* 314: 257–260
- Chae HZ, Chung SJ, Rhee SG (1994a) Thioredoxin-dependent peroxide reductase from yeast. *J Biol Chem* 269: 27670–27678
- Chae HZ, Uhm TB, Rhee SG (1994b) Dimerization of thiol-specific antioxidant and the essential role of cysteine 47. *Proc Natl Acad Sci USA* 91: 7022–7026
- Cheong NE, Choi YO, Lee KO, Kim WY, Jung BG, Chi YH, Jeong JS, Kim K, Cho MJ, Lee SY (1999) Molecular cloning, expression, and functional characterization of a 2 Cys-peroxiredoxin in Chinese cabbage. *Plant Mol Biol* 40: 825–834
- Choi YO, Cheong NE, Lee KO, Jung BG, Hong CH, Jeong JH, Chi YH, Kim K, Cho MJ, Lee SY (1999) Cloning and expression of a new isotype of the peroxiredoxin gene of Chinese cabbage and its comparison to 2 Cys-peroxiredoxin isolated from the same plant. *Biochem Biophys Res Commun* 258: 768–771
- Enright AJ, Iliopoulos I, Kyrpidis NC, Ouzounis CA (1999) Protein interaction maps for complete genomes based on gene fusion events. *Nature* 402: 86–90
- Halliwell B, Gutteridge JM (1990) Role of free radicals and catalytic metal ions in human disease: an overview. *Methods Enzymol* 186: 1–85
- Haslekas C, Stacy RA, Nygaard V, Culianez-Macia FA, Aalen RB (1998) The expression of a peroxiredoxin antioxidant gene, *AtPer1*, in *Arabidopsis thaliana* is seed-specific and related to dormancy. *Plant Mol Biol* 36: 833–845
- Jacquot JP, Gadal P, Nishizawa AN, Yee BC, Crawford NA, Buchanan BB (1984) Enzyme regulation in C4 photosynthesis: mechanism of activation of NADP-malate dehydrogenase by reduced thioredoxin. *Arch Biochem Biophys* 228: 170–178
- Jacquot JP, Rivera-Madrid R, Marinho P, Kollarova M, Le Marechal P, Miginiac-Maslow M, Meyer Y (1994) *Arabidopsis thaliana* NAPHP thioredoxin reductase. cDNA characterization and expression of the recombinant protein in *Escherichia coli*. *J Mol Biol* 235: 1357–1363
- Ishiwatari Y, Fujiwara T, McFarland KC, Nemoto K, Hayashi H, Chino M, Lucas WJ (1998) Rice phloem thioredoxin h has the capacity to mediate its own cell-to-cell transport through plasmodesmata. *Planta* 205: 12–22
- Jin DY, Chae HZ, Rhee SG, Jeang KT (1997) Regulatory role for a novel human thioredoxin peroxidase in NF-kappaB activation. *J Biol Chem* 272: 30952–30961
- Kang SW, Baines IC, Rhee SG (1998) Characterization of a mammalian peroxiredoxin that contains one conserved cysteine. *J Biol Chem* 273: 6303–6311
- Kim H, Lee TH, Park ES, Suh JM, Park SJ, Chung HK, Kwon OY, Kim YK, Ro HK, Shong M (2000) Role of peroxiredoxins in regulating intracellular hydrogen peroxide and hydrogen peroxide-induced apoptosis in thyroid cells. *J Biol Chem* 275: 18266–18270

- Knoblauch M, van Bel AJ (1998) Sieve tubes in action. *Plant Cell* 10: 35–50
- Laemmli UK (1970) Cleavage of structural proteins during the assembly of the head of bacteriophage T4. *Nature* 227: 680–685
- Lewis ML, Miki K, Ueda T (2000) FePer 1, a gene encoding an evolutionarily conserved 1-Cys peroxiredoxin in buckwheat (*Fagopyrum esculentum* Moench) is expressed in a seed-specific manner and induced during seed germination. *Gene* 246: 81–91
- Makrides SC (1996) Strategies for achieving high-level expression of genes in *Escherichia coli*. *Microbiol Rev* 60: 512–538
- Marcotte EM, Pellegrini M, Ng HL, Rice DW, Yeates TO, Eisenberg D (1999) Detecting protein function and protein-protein interactions from genome sequences. *Science* 285: 751–753
- Pedrajas JR, Miranda-Vizuete A, Javanmardy N, Gustafsson JA, Spyrou G (2000) Mitochondria of *Saccharomyces cerevisiae* contain one-conserved cysteine type peroxiredoxin with thioredoxin peroxidase activity. *J Biol Chem* 275: 16296–16301
- Prosperi MT, Ferbus D, Karczinski I, Goubin G (1993) A human cDNA corresponding to a gene overexpressed during cell proliferation encodes a product sharing homology with amoebic and bacterial proteins. *J Biol Chem* 268: 11050–11056
- Rhee SG, Kang SW, Netto LE, Seo MS, Stadtman ER (1999) A family of novel peroxidases, peroxiredoxins. *Biofactors* 10: 207–209
- Rhee SG, Kim KH, Chae HZ, Yim MB, Uchida K, Netto LE, Stadtman ER (1994) Antioxidant defense mechanisms: a new thiol-specific antioxidant enzyme. *Ann N Y Acad Sci* 738: 86–92
- Rivera-Madrid R, Mestres D, Marinho P, Jacquot JP, Decottignies P, Miginiac-Maslow M, Meyer Y (1995) Evidence for five divergent thioredoxin h sequences in *Arabidopsis thaliana*. *Proc Natl Acad Sci USA* 92: 5620–5624
- Sambrook J, Fritsch EF, Maniatis T (1989) *Molecular cloning: A Laboratory Manual*. Cold Spring Harbor Laboratory Press, Cold Spring Harbor, NY
- Schenk PM, Baumann S, Mattes R, Steinbiss HH (1995) Improved high-level expression system for eukaryotic genes in *Escherichia coli* using T7 RNA polymerase and rare Arg-tRNAs. *Biotechniques* 19: 196–200
- Schröder E, Ponting CP (1998) Evidence that peroxiredoxins are novel members of the thioredoxin fold superfamily. *Protein Sci* 7: 2465–2468
- Seo MS, Kang SW, Kim K, Baines IC, Lee TH, Rhee SG (2000) Identification of a new type of mammalian peroxiredoxin that forms an intramolecular disulfide as a reaction intermediate. *J Biol Chem* 275: 20346–20354
- Stacy RA, Nordeng TW, Cullianez-Macia FA, Aalen RB (1999) The dormancy-related peroxiredoxin anti-oxidant, PER1, is localized to the nucleus of barley embryo and aleurone cells. *Plant J* 19: 1–8
- Stein M, Jacquot JP, Jeannette E, Decottignies P, Hodges M, Lancelin JM, Mittard V, Schmitter JM, Miginiac-Maslow M (1995) *Chlamydomonas reinhardtii* thioredoxins: structure of the genes coding for the chloroplastic m and cytosolic h isoforms; expression in *Escherichia coli* of the recombinant proteins, purification and biochemical properties. *Plant Mol Biol* 28: 487–503
- Sullivan DM, Wehr NB, Fergusson MM, Levine RL, Finkel T (2000) Identification of oxidant-sensitive proteins: TNF-alpha induces protein glutathiolation. *Biochemistry* 39: 11121–11128
- Szedzerkenyi J, Komor E, Schobert C (1997) Cloning of the cDNA for glutaredoxin, an abundant sieve-tube exudate protein from *Ricinus communis* L. and characterization of the glutathione-dependent thiol-reduction system in sieve tubes. *Planta* 202: 349–356
- Verdoucq L, Vignols F, Jacquot JP, Chartier Y, Meyer Y (1999) In vivo characterization of a thioredoxin h target protein defines a new peroxiredoxin family. *J Biol Chem* 274: 19714–19722
- Wieleś B, Van Noort J, Drijfhout JW, Offringa R, Holmgren A, Ottenhoff TH (1995) Purification and functional analysis of the *Mycobacterium leprae* thioredoxin/thioredoxin reductase hybrid protein. *J Biol Chem* 270: 25604–25606
- Yamamoto T, Matsui Y, Natori S, Obinata M (1989) Cloning of a housekeeping-type gene (MER5) preferentially expressed in murine erythroleukemia cells. *Gene* 80: 337–343
- Zhang P, Liu B, Kang SW, Seo MS, Rhee SG, Obeid LM (1997) Thioredoxin peroxidase is a novel inhibitor of apoptosis with a mechanism distinct from that of Bcl-2. *J Biol Chem* 272: 30615–30618
- Zhou Y, Kok KH, Chun AC, Wong CM, Wu HW, Lin MC, Fung PC, Kung H, Jin DY (2000) Mouse peroxiredoxin V is a thioredoxin peroxidase that inhibits p53-induced apoptosis. *Biochem Biophys Res Commun* 268: 921–927

Article numéro 12 :

**Rouhier N, Gelhaye E, Jacquot JP. (2002)**

*Glutaredoxin-dependent peroxiredoxin from poplar: protein-protein interaction and catalytic mechanism.*

**J. Biol. Chem. 277(16):13609-14.**

Afin de déterminer le mécanisme catalytique de la Prx de type II et son mode de régénération par la Grx, les protéines recombinantes mutées sur l'une ou l'autre des deux cystéines contenues dans la Prx, Prx C51A et Prx C76A, ont été produites chez *E. coli*. Par ailleurs, une protéine de mammifère, homologue à la Prx de type II, appelée Prx V possède une cystéine additionnelle en position C-terminale (C152). Cette cystéine est impliquée dans la formation d'un pont disulfure intramoléculaire avec la cystéine 51, lequel est ensuite réduit par les Trx. Pour mimer cette protéine, la protéine recombinante Prx V152C a également été produite et purifiée. Les tests d'activité effectués en combinant les différentes protéines mutées générées, ainsi que les essais de formation d'hétérodimères entre ces différentes protéines mutantes, ont permis de comprendre l'interaction entre Trx ou Grx et Prx. Ainsi, la cystéine 51 de la Prx est la cystéine catalytique qui est transformée en cystéine SOH lors de la catalyse, alors que la cystéine 76 n'intervient pas dans le mécanisme, même si l'activité de cette protéine mutante est réduite par rapport à la protéine sauvage. La régénération de l'enzyme est effectuée par réduction de ce SOH directement par les Trx ou Grx aboutissant à la formation d'un pont disulfure intermédiaire qui sera réduit par attaque de la deuxième cystéine des Trx ou Grx. L'interaction entre les protéines a été confirmée par la formation de complexes entre les mutants monocystéiniques de Trx ou Grx et la Prx sauvage. Toutefois, l'étude du mutant Grx C30S a permis de montrer que la présence de la deuxième cystéine du site actif des Grx n'est pas obligatoire et que tout se passe comme si le GSH ou plus vraisemblablement une autre molécule de Grx C30S pouvait rompre ce pont disulfure mixte. De manière tout à fait intéressante, Prx V152C est actif avec Trx mais pas avec Grx pour une raison que nous n'avons pas déterminée mais qui pourrait être la formation d'un pont disulfure entre les cystéines 51 et 152 qui serait réduit par Trx mais pas Grx. La résolution de la structure de la Prx sauvage et de la Prx V152C devrait permettre de répondre à cette question.

## Glutaredoxin-dependent Peroxiredoxin from Poplar

PROTEIN-PROTEIN INTERACTION AND CATALYTIC MECHANISM\*

Received for publication, December 3, 2001, and in revised form, January 28, 2002  
Published, JBC Papers in Press, February 6, 2002, DOI 10.1074/jbc.M111489200

Nicolas Rouhier, Eric Gelhaye, and Jean Pierre Jacquot‡

From the Unité mixte de recherche IaM INRA-UHP Nancy I, Biochimie et Biologie Moléculaire Végétales, Université Henri Poincaré, 54506 Vandoeuvre Cedex, France

Recently, a poplar phloem peroxiredoxin (Prx) was found to accept both glutaredoxin (Grx) and thioredoxin (Trx) as proton donors. To investigate the catalytic mechanism of the Grx-dependent reduction of hydroperoxides catalyzed by Prx, a series of cysteineic mutants was constructed. Mutation of the most N-terminal conserved cysteine of Prx (Cys-51) demonstrates that it is the catalytic one. The second cysteine (Cys-76) is not essential for peroxiredoxin activity because the C76A mutant retained ~25% of the wild type Prx activity. Only one cysteine of the Grx active site (Cys-27) is essential for peroxiredoxin catalysis, indicating that Grx can act in this reaction either via a dithiol or a monothiol pathway. The creation of covalent heterodimers between Prx and Grx mutants confirms that Prx Cys-51 and Grx Cys-27 are the two residues involved in the catalytic mechanism. The integration of a third cysteine in position 152 of the Prx, making it similar in sequence to the Trx-dependent human Prx V, resulted in a protein that had no detectable activity with Grx but kept activity with Trx. Based on these experimental results, a catalytic mechanism is proposed to explain the Grx- and Trx-dependent activities of poplar Prx.

Peroxiredoxins (Prxs)<sup>1</sup> constitute a recently discovered family of non-heme peroxidases present in all organisms from prokaryotes to eukaryotes, and they catalyze the reduction of various hydroperoxides into the corresponding alcohol and water (1). Currently, these proteins are the subject of numerous studies because their function seems to be particularly important in the detoxification of reactive oxygen species that can cause serious damage to the nucleic acids, proteins, and lipids (2–4). Prx is also involved in the control of signal transduction by modulating the reactive oxygen species-mediated cellular responses and by regulating transcription factors (5–7).

All the Prx isoforms have in common a conserved catalytic cysteine, localized in the N-terminal part of the protein, that is converted into a sulfenic acid by hydroperoxides (8). This cysteine was demonstrated by site-directed mutagenesis to be essential for catalysis (9). Based mainly on the number of

conserved cysteines, a classification has been proposed for the multiple existing Prxs. The 1-Cys Prxs mediate the reduction of H<sub>2</sub>O<sub>2</sub> with the use of an unknown proton donor, which could be Trx for a mitochondrial 1-Cys Prx from *Saccharomyces cerevisiae* (10, 11). Recently, human cyclophilin A was identified as an electron donor to the mammalian Prx VI, the only mammalian 1-Cys Prx characterized, and also to all known mammalian Prxs (12). Among the Prxs with two conserved cysteines, at least three classes can be distinguished, according to the position of the cysteines. The first class, comprising mammalian Prx V, includes monomeric enzymes that form an intramolecular disulfide bridge as a reaction intermediate (13, 14). The second class is formed by the homologues of the bacterioferritin co-migratory protein, which are also shown to be monomeric enzymes with an intramolecular disulfide bridge in the oxidized state (15, 16). In this second class, the spacing between the two cysteines that are part of the disulfide bridge is considerably shorter, consistently containing 4 amino acids, instead of the ~100 amino acids for the first class. The third class, which includes mammalian Prx I to IV, consists of dimeric enzymes that form an intermolecular disulfide bridge between two identical subunits (14, 17). Despite these differences, the three types of 2-Cys Prx use Trx as a proton donor.

In a previous report, a poplar phloem Prx was characterized (18). This Prx is a small protein of 162 amino acids that contains only two cysteines in position 51 and 76. The primary sequence is quite different from that of the 1-Cys Prxs and most of the 2-Cys Prxs, especially because of the distance that separates the two cysteines. An unexpected finding was that this Prx could use Trx but also Grx as a proton donor for its catalysis (18). This Prx has been referred to as type C Prx, whereas the other 2-Cys Prxs, which use only Trx, were referred to as type A Prx, and 1-Cys Prxs were referred to as type B Prx. Among the biochemically well-characterized Prxs, one of the closest proteins is the mammalian Prx V. This enzyme also comprises 162 amino acids and displays 40% identity to poplar Prx at the amino acid level. A notable difference is the presence of an additional cysteine in position 152 that is linked together with Cys-51 to form an intramolecular disulfide bridge in Prx V (14). A Prx from Chinese cabbage, highly homologous to poplar Prx, was also shown to be a Trx-dependent enzyme, but no attempt was made to evaluate the potential for Grx as a proton donor in this work (19). To get a better understanding of the catalytic mechanism of this Grx-dependent Prx, cysteineic mutants of Grx and Prx have been created by site-directed mutagenesis. Based on kinetic measurements and the creation of heterodimers, a new mechanism for the Grx-dependent Prx activity is proposed.

### EXPERIMENTAL PROCEDURES

**Materials**—NADPH was obtained from Roche Molecular Biochemicals; diamide,  $\beta$ -mercaptoethanol, glutathione reductase, and reduced

\* The costs of publication of this article were defrayed in part by the payment of page charges. This article must therefore be hereby marked "advertisement" in accordance with 18 U.S.C. Section 1734 solely to indicate this fact.

‡ To whom correspondence should be addressed: Unité mixte de recherche IaM INRA-UHP Nancy I, Biochimie et Biologie Moléculaire Végétales, Université Henri Poincaré, BP 239 Blvd. des Aiguillettes, 54506 Vandoeuvre Cedex, France. Tel.: 33-3-839-12253; E-mail: j2p@scbiol.uhp-nancy.fr.

<sup>1</sup> The abbreviations used are: Prx, peroxiredoxin; Grx, glutaredoxin; Trx, thioredoxin; WT, wild type; DTNB, 5,5'-dithiobis(nitrobenzoic acid).

FIG. 1. Multiple alignment of related sequences to poplar Prx. This comparison was realized using CLUSTALW software. The GenBank™ accession numbers of the sequences aligned with poplar Prx are as follows: *O. sativa*, AAG40130; *C. boidinii*, AAA34357; human Prx V AOB166, P30044; *B. rapa*, AAD33602; and *A. thaliana*, AAG48827. The asterisk corresponds to strict identity, the colon corresponds to functional homology, and the period corresponds to structural homology.

Arabidopsis thal	1	MAPI AVGDVVPDGI SFFD - ENDLQQTASVHSLAACKKVI LFGVPGAF 48
Brassica rapa	1	MAPI AVGDVVPDGI SFFD - ENDLQQTASVHSLAACKKVI LFGVPGAF 48
Populus trichoc	1	MAPI AVGDVLPDGLAYFD - EQDQLQEVSVHSLVAGKVKVI LFGVPGAF 48
Oryza sativa	1	MAPVAVGDI LDPDGLQWFD - GEKRLQCVSVHSLAACKKVI LFGVPGAF 48
Candida boidinii	1	MAPI KRGRFPPTDDVYTI PPEGGEPGLELSKFKVTKKVVVSVPGAF 50
Human Prx V	1	MAPI KVGDAL P - AVEVFE - - GEPGNKQVLAELFKKCKKVI LFGVPGAF 45
		***: ** * . . . . . ** . . . . . *****
Arabidopsis thal	49	PTSMKHVPGEI EKAEELKSKGVDEI I PFSVNDPFVMAKAWGKTYP - ENK 96
Brassica rapa	49	PTSMKHVPGEI EKAEELKSKGVDEI I PFSVNDPFVMAKAWGKTYP - ENK 96
Populus trichoc	49	PTSLKHVPGEI EKAGELKSKGVTEI L PFSVNDPFVMAKAWKYSY - ENK 96
Oryza sativa	49	PTSNQKVPGEI NQAEQLKAKGVDDI L PFSVNDPFVMAKAWKYSY - ENK 96
Candida boidinii	51	PPFTEQELPGYI KNLPRI LSKGVDFVLT I PNDPFVVLKGVKELGAADAK 100
Human Prx V	46	POSSKTHLPGEVQAEALKAGVQVVALI SVNDAFVTGEVGRATK - AEG 93
		* * . * . . . . . * . . . . . * * . . . . *
Arabidopsis thal	97	HVKFVADGSGEYTHLGLLELDLKRKQ - LGVR - SRRFALLLD - LKVTVAN 143
Brassica rapa	97	HVKFVADGSGEYTKLLGLELDLKRKQ - LGVR - SRRFALLI DN - LKVTVAN 143
Populus trichoc	97	HVKFLADGSAITYTHALGLELDLQCKG - LGTR - SRRFALLVDD - LKVKAAAN 143
Oryza sativa	97	HVKFLADGLGYTHALGLELDLSEKQ - LGR R - SRRFALLADN - LKVTVAN 143
Candida boidinii	101	KLKVFSDPNLKLTKLGSYI LLSAI G - LGTR - SGRLLI VNRSYI VEYAA 149
Human Prx V	94	KVRLLDPTGAFGKETLILLDDSLVSI FGRRLKRFSSMVQD - QI VKALN 142
		. . . . . * . . . . . * * . . . . *
Arabidopsis thal	144	VE-SGGFTSSADEI LKAL 162
Brassica rapa	144	VE-SGGFTSSADEI LKAL 162
Populus trichoc	144	IE-OGGFTSSADEI LKTL 162
Oryza sativa	144	IE-EGGFTSSADEI LKAL 162
Candida boidinii	150	IE-NQGEVDSACKI I AKL 167
Human Prx V	143	VEPDGTQLTSLAPNI SQL 162
		* * . * . . . . . *

glutathione were from Sigma. Dithiothreitol, isopropyl-1-thio-β-D-galactopyranoside, kanamycin, and ampicillin were from Fermentas.

**Cloning and Mutations of Grx and Prx**—The procedures for the isolation of the cDNAs and their subsequent cloning in expression plasmids are described in Refs. 18, 20, and 21. The mutagenesis of poplar Grx was effected as we described (31). The Prx mutants C51A, C76A, and V152C were generated by PCR using the oligonucleotides shown below (*Nco*I and *Bam*HI sites are underlined, mutagenic bases are in bold).

Cloning oligonucleotides were as follows: direct, 5'-GGGGCCATGG-CCCGATTGCTGTTGGT-3'; and reverse, 5'-GGGGGGGATCCTCAA-AGATCCTTGAGGATATCCTCGGCACT-3'. Mutagenic oligonucleotides were as follows: C51A direct, 5'-GCCTTCACCCACCAGCCAG-CCTGAAGCATGTG-3'; C51A reverse, 5'-CACATGCTTCAAGCTGGC-GGTGGGGTGAAGGC-3'; C76A direct, 5'-GTTACTGAAAATTTTGGC-CATCAGCGTCAACGAC-3'; C76A reverse, 5'-GTCGTTGACGCTGAT-GGCCAAAATTTCAAGTAAAC-3'; V152C direct, 5'-GGGGTGGAGAAAT-TCACTTGCTCCAGTCCGAGGATATC-3'; and V152C reverse, 5'-GATATCCTCGGCACTGGAGCAAGTGAATTCTCCACCC-3'.

The mutated PCR products that contained the restriction sites were in turn cloned into the expression plasmid pET-3d, yielding the constructions pET Prx C51A, pET Prx C76A, and pET Prx V152C. The sequences of the recombinant plasmids were verified by sequencing.

**Expression and Purification of the Recombinant Proteins**—All procedures for the expression and purification of *Arabidopsis thaliana* NADPH Trx reductase, poplar Trx h1, and WT and mutant Grx are described elsewhere (20, 21, 23, 31). For the expression of Prx, the recombinant plasmids were used to transform *Escherichia coli* strain BL21(DE3), which was also co-transformed with the plasmid helper pSBET as described previously (18, 24). Because preliminary experiments indicated that Prx is susceptible to oxidation, all purification steps for the wild type and the three mutant proteins were done in the presence of 14 mM β-mercaptoethanol.

**Thiol Content Titration**—The thiol content of each protein preparation was measured using the DTNB procedure. To eliminate the β-mercaptoethanol, 1 mg of each protein was incubated with 10% trichloroacetic acid for 30 min on ice. The mixture was then centrifuged for 15 min at 13,000 rpm, and the pellet was washed three times with 1 ml of 2% trichloroacetic acid. The pellet was resuspended in 100 mM Tris-HCl, pH 8, and 1 mM EDTA, and the protein concentration was determined by measuring the absorbance at 280 nm. SDS was then added to a final concentration of 1%, and the reaction was started by adding 100 μM DTNB. The reaction mixture was stored in the dark for 20 min, and the absorbance at 412 nm was measured. A second measurement was performed after a 30-min incubation in the dark. Both measurements gave identical results. Similar results were obtained when we used 80% acetone as a precipitant instead of trichloroacetic acid.

**Prx Activity Measurement**—The reduction of H<sub>2</sub>O<sub>2</sub> by poplar Prx in the presence of the Trx or Grx system was followed spectrophotometrically using a Cary 50 spectrophotometer as described in Ref. 18. The activities were measured at a fixed concentration of Prx (2.5 μM) and at variable concentrations of Grx or Trx.

**Formation and Separation of the Heterodimers**—1.25 μg of Prx and Grx were mixed in the presence of TE buffer (30 mM Tris-HCl, pH 8, and 1 mM EDTA) to a final volume of 10 μl. This reaction mixture was incubated at room temperature for 2–3 min before the addition of 10 mM diamide. The mixture was incubated at room temperature for 20 min and then subjected to 14% SDS-PAGE in the presence of an equivalent volume of a nonreducing sample buffer (0.5 M Tris-HCl, pH 6.8, 4% SDS, 20% glycerol, and bromophenol blue) (25). When needed, 10 mM dithiothreitol or 20–50 mM glutathione was added after incubation in the presence of diamide to reduce the covalent disulfide adducts between Prx and Grx.

**Western Blotting**—2 μl of the mixture described above were subjected to 14% SDS-PAGE before transfer. The immunodetection using the Immune Star Goat Anti Rabbit Detection Kit from Bio-Rad was performed as described in Ref. 18. Rabbit polyclonal antibodies against Trx, Grx, and Prx were purified onto affinity columns according to the procedure described for Prx antibodies in Ref. 18.

## RESULTS

**Homologues of Poplar Prx among Other Species**—A previous study has indicated that poplar Prx differs from the other peroxiredoxins characterized thus far, essentially by the position of the conserved cysteine residues and by the overall length of the sequence (18). As detailed in the "Introduction," this class of new Prxs was called type C Prx, whereas 2-Cys Prxs were named type A Prx, and 1-Cys Prxs were called type B Prx. A number of sequences similar to type C poplar Prx have now appeared in the literature, and an amino acid comparison of some of the closest relatives is given in Fig. 1. Poplar Prx is strongly homologous to the other plant Prxs of its class (76%, 81%, and 82% amino acid identity with *Oryza sativa*, *Brassica rapa*, and *A. thaliana*, respectively) and also to the well-characterized PMP20 protein from *Candida boidinii* and to the human Prx V (42% and 40% amino acid identity, respectively) (Fig. 1). Nevertheless, an important difference is the presence of an additional cysteine in human Prx in position 152; the poplar and all other nonmammalian sequences do not possess

TABLE I

Relative activities of the various Prx preparations with Trx and Grx

Data are expressed in  $\mu\text{mol}$  of NADPH oxidized/min/mg protein. The measurements were effected at  $30^\circ\text{C}$  with  $2.5\ \mu\text{M}$  Prx in the presence of  $2.5\ \mu\text{M}$  Trx or Grx. Initial Grx corresponds to the construction pET-Grx 1B, and improved Grx corresponds to pET-Grx 3 as described in Ref. 20. 1.d., limit of detection.

	Initial Grx	Improved Grx	Trx
Prx oxidizing conditions	1.d.	3.55	0.55
Prx reducing conditions	1.d.	4.02	0.82

this additional cysteine. This particularity is examined here in terms of catalytic efficiency.

**Improvement of the Purification of Wild Type Prx and Grx**—In a previous work, we have shown that type C Prx could use both Grx and Trx as proton donors for catalysis. In this initial work, rather high concentrations of Trx or Grx were required in the *in vitro* measurement of peroxidase activity (18). Moreover, the specific activity of the enzyme remained low. We have improved this system in two respects: (i) the truncated form of poplar Grx, which was used in the earlier experiments, was replaced by a C-terminal-extended protein, which was both more stable and more active (20); and (ii) because we observed that Prx was susceptible to oxidation, its purification and subsequent storage were carried out in the presence of  $\beta$ -mercaptoethanol to avoid an irreversible oxidation of the catalytic cysteine. These changes resulted in a considerable enhancement of enzymatic activity, as shown in Table I. At a saturating Grx concentration ( $\sim 10\ \mu\text{M}$ ), the maximal specific activity of the enzyme is  $8\ \mu\text{mol}$  NADPH oxidized/min $^{-1}$ /mg protein $^{-1}$ . This value is similar to those reported for human peroxiredoxins and the *E. coli* bacterioferritin co-migratory protein (10, 14, 15). The specific activities recorded under the conditions of Table I suggest that Grx might be a better donor than Trx for poplar Prx. The maximal specific activity at a saturating Trx concentration estimated from the results in Fig. 3,  $1.5\ \mu\text{mol}$  NADPH oxidized/min $^{-1}$ /mg protein $^{-1}$ , also agrees with that proposal. However, these data should be treated with caution because the assays for Prx activity are indirect and involve the coupling of several components.

**Production of Mutant Proteins by Site-directed Mutagenesis**—Two monocysteine mutants, called C27S and C30S, have been created to modify the active site of poplar Grx (31). In addition, the mutants C51A, C76A, and V152C have been engineered to explore the reactivity of poplar Prx. All these cysteine mutants were purified in the presence of  $\beta$ -mercaptoethanol to avoid undesired dimerizations. Fig. 2 shows that all Grx and Trx h1 preparations are highly homogeneous. As observed previously, all Prx preparations exhibited a protein doublet that cannot be eliminated by the addition of an excess of reductant (18). The reason for this behavior is unknown, but all biochemical and structural evidence gathered otherwise indicates that the protein is nevertheless highly homogeneous. Several reports in the literature indicate that the catalytic cysteine of peroxiredoxins can be transformed into sulfenic, sulfonic, or sulfinic acids, and this has been proposed as the reason for the formation of apparent protein doublets (10). The titration results with DTNB do not really support such a hypothesis for the poplar protein (see below). Besides, as observed previously, if such a modification occurs, it is not the result of the purification procedure because similar protein doublets were observed after direct lysis of freshly harvested bacteria (data not shown).

**Thiol Titration of the Recombinant Proteins**—The thiol content of all protein preparations has been estimated using the DTNB method. All titrations were made on enzymes that were freed from reductant and after the addition of SDS (see “Ex-

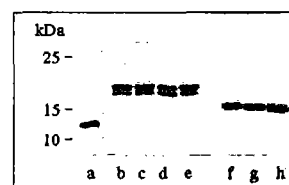

FIG. 2. Analysis of purified recombinant proteins by SDS-PAGE. 14% SDS-PAGE under reducing conditions showing recombinant Trx, Grx, and Prx samples. Lane a, WT Trx h1; lane b, WT Prx; lane c, Prx C51A; lane d, Prx C76A; lane e, Prx V152C; lane f, WT Grx; lane g, Grx C27S; lane h, Grx C30S.

perimental Procedures”). Consequently, all thiols are titrated, regardless of whether or not they were accessible in the native protein. A summary of these data is shown in Table II. For Grx, the results are quite simple; nearly two thiols are titrated for the reduced WT protein, and no SH group is present in the oxidized WT protein, suggesting that the two Cys residues are indeed linked in a disulfide bridge. The monocysteine mutants of Grx give values around 1 SH/mol protein, as expected. For Prx, the results are more complex to analyze and depend on whether the protein was isolated in the presence or absence of a reductant. When prepared under nonreducing conditions, the WT Prx shows nearly 2 SH/enzyme monomer, and it appears that the C51A and C76A mutants are partially oxidized because values lower than 1 SH/mol were recorded. The V152C mutant gives a value of 2.6 SH/mol, nearly in agreement with the expected 3 SH/mol. When the Prx preparations were made in the presence of the monothiol reductant  $\beta$ -mercaptoethanol, very contrasting results were obtained. The C51A mutant showed nearly 1 SH/mol, but all other preparations had a thiol content that was reduced by about 1 SH group compared with the expected theoretical value. We interpret this as the result of a likely interaction between the thiol group of Cys-51 and  $\beta$ -mercaptoethanol that can give rise to a mixed disulfide that cannot be titrated with DTNB. As Prx preparation treated with the dithiol reductant dithiothreitol titrate as the enzyme prepared under oxidizing conditions, this formation of mixed disulfide is postulated to be specific for  $\beta$ -mercaptoethanol. Such a behavior has already been described for the bovine 1-Cys peroxiredoxin (26). Alternatively, because the thiol titrations are not always in perfect agreement with the theoretical values, this could also indicate that a portion of the peroxiredoxin molecules is in a denatured oxidized form with an internal disulfide bridge as described by Kang *et al.* for human 1-Cys Prx (10) or that a portion of the catalytic cysteine is in an oxidized form.

**Peroxidase Activity of the Mutant Peroxiredoxins**—The catalytic capacity of all Prx mutants has been evaluated in the presence of the various engineered Grxs as proton donors. This has been tested in a coupled enzymatic reaction where the peroxiredoxin-catalyzed conversion of  $\text{H}_2\text{O}_2$  is linked to NADPH oxidation via glutathione reductase, glutathione, and glutaredoxin. We have shown previously, using the 2-hydroxyethyl disulfide and dehydroascorbate reduction tests, that Cys-27 is the catalytic residue of Grx, and Cys-30 is generally dispensable in those reactions (31).

Fig. 3 shows the  $\text{H}_2\text{O}_2$ -dependent NADPH oxidizing activities of the various engineered peroxiredoxins as a function of Grx concentrations ranging from  $0.5$  to  $20\ \mu\text{M}$ . Only four combinations were found to promote catalysis. The best reactivity was obtained when WT Prx was associated with WT Grx. The mutation of Cys-30 of Grx (C30S) has little effect because the rate of catalysis with this mutant is nearly identical to the one obtained with WT Grx. The other associations that are catalytically competent are those between Prx C76A and Grx WT or



TABLE II  
Thiol content of Grx and Prx purified under oxidizing or reducing conditions

Thiols were titrated using the reduction of DTNB as described under "Experimental Procedures." Data are expressed in mol SH/mol enzyme. n.d., not determined. The S.D. is typically  $\pm 0.2$  SH/mol SH.

	Oxidizing conditions	Reducing conditions
Grx WT	0.05	1.67
Grx C27S	n.d.	0.88
Grx C30S	n.d.	0.93
Prx WT	1.7	0.9
Prx C51A	0.28	0.87
Prx C76A	0.33	0.19
Prx V152C	2.6	1.4

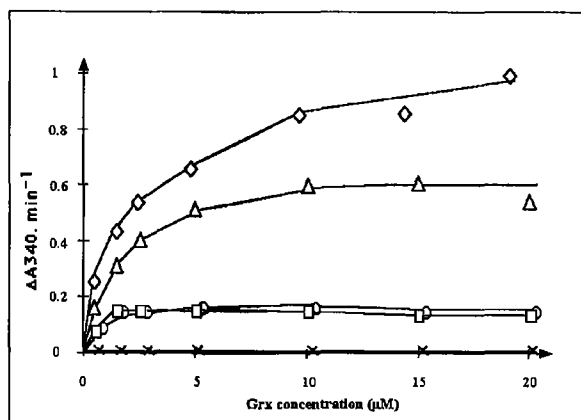

FIG. 3. Grx-dependent Prx activities.  $H_2O_2$  consumption by poplar Prx in the presence of the Grx system was followed in the coupled reaction system by NADPH oxidation/min as a function of Grx concentration. The WT and mutant Prx were associated in this test with each of the Grxs: WT Prx associated with WT Grx ( $\diamond$ ) or Grx C30S ( $\Delta$ ), Prx C76A associated with WT Grx ( $\circ$ ) or Grx C30S ( $\square$ ), Prx C51A associated with any Grx, Prx V152C associated with any Grx, WT Prx associated with Grx C27S, and Prx C76A associated with Grx C27S (X).

C30S. However, the activities of the C76S mutant are reduced by approximately 75% compared with those recorded with WT Prx. Another observation is that the Prx C51A and V152C enzymes are completely inactive with Grx as a proton donor. A last piece of information is that the C27S mutant of Grx is unable to promote catalysis for all Prxs tested.

Fig. 4 presents the catalytic activity of the Prx enzymes, in the presence of WT Trx as a proton donor. In this case, the Grx generating system was replaced by the Trx system, which is composed of the *A. thaliana* NADPH thioredoxin reductase and poplar Trx h1 (18). The reduction of poplar Trx by the *Arabidopsis* NADPH thioredoxin reductase was previously shown to be functional using the DTNB reduction test (21). In general, similar results were obtained with the Trx system: the WT Prx was the most active catalyst, the mutation C51A abolished catalysis, and C76A had a depressing effect. The most striking difference is that the V152C protein, which was inactive with Grx as a proton donor, was catalytically active with Trx (Fig. 4,  $\blacklozenge$ ). No saturation of Prx V152C enzyme activity could be recorded with Trx up to concentrations of  $50 \mu M$  (data not shown).

From the data in Figs. 3 and 4,  $K_m$  values can be determined to characterize interactions between Prx and Grx or Trx. Similar values were obtained for Grx and Trx (2.5 and  $3 \mu M$ , respectively). These values are in good agreement with other parameters published in the literature for Trx (14).

**Heterodimer Formation**—The mutation of the cysteine that is potentially involved in the breaking of the mixed disulfide intermediates stabilizes the heterodimers between Trx or Grx and their interacting partners (27). We have taken advantage

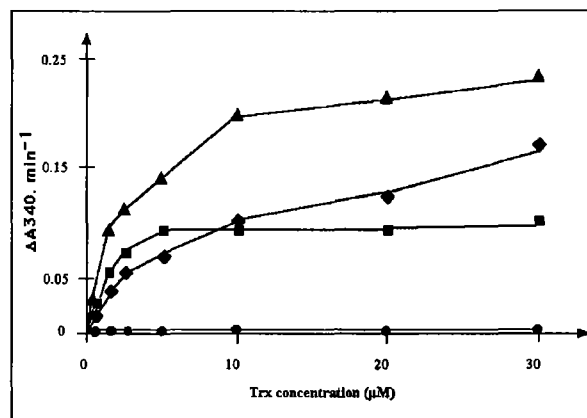

FIG. 4. Trx-dependent Prx activities.  $H_2O_2$  consumption by poplar Prx in the presence of the Trx system was followed in a coupled reaction system by NADPH oxidation/min. Activities are plotted as a function of poplar Trx h1 concentration. WT Trx with WT Prx,  $\blacktriangle$ ; Prx V152C,  $\blacklozenge$ ; Prx C76A,  $\blacksquare$ ; Prx C51A,  $\bullet$ .

of that property to create heterodimers between the peroxiredoxin and glutaredoxin molecules. The covalent heterodimer formation was greatly improved using the oxidant diamide. The four different Prx preparations (WT, C51A, C76A, and V152C) were incubated with three different versions of the Grx (WT, C27S, and C30S). Fig. 5 shows the results of these associations. In all assays, the Grx polypeptide is present with an apparent molecular mass of 15 kDa and the Prx is present with the usual doublet at  $\sim 18$  kDa. By running the proteins individually and based on the molecular mass determinations, we could assess the additional polypeptides as follows: the 30-kDa polypeptide is likely a Grx dimer, the 33-kDa polypeptide a heterodimer, and the 37-kDa polypeptide is a Prx dimer. Fig. 5 shows that a heterodimer is efficiently created when using Grx C30S together with either WT Prx (lane c) or Prx C76A (lane i) and is created much less efficiently with Prx V152C (lane k). The Grx C27S mutant was also able to create heterodimers with the same Prx preparations, but with a much reduced efficiency (lanes b, h, and k). Strikingly, Prx C51A is the only preparation that does not form any dimer with all Grx (lanes d–f), indicating that this residue is an essential partner in the redox interaction. The WT Grx is unable to create any stable association with any Prx (lanes a, d, g, and j). Finally, a major additional polypeptide of  $\sim 48$  kDa is present in the interaction between Grx C30S and Prx V152C. This high molecular mass could correspond to a Prx linked with two Grx molecules.

The nature of these polypeptides was confirmed by Western blotting experiments. As shown in Fig. 6, anti-Grx antibodies do not react with Prx (lane f) and vice versa (lane g). This experiment reveals that the band at 30 kDa is indeed a Grx dimer (lane d), the one at 33 kDa is a heterodimer between Grx and Prx (lanes e and h), and the one at 37 kDa is a dimer of Prx (lane i).

A further confirmation of the nature of the heterodimer is shown in Fig. 7. The heterodimer generated in the presence of diamide can be reduced in the presence of excess dithiothreitol or reduced glutathione (Fig. 7, lanes b and d). The disappearance of the heterodimer polypeptide after reduction confirms that the two chains are indeed linked together via a disulfide bond.

#### DISCUSSION

The poplar Prx described here is the only characterized Prx that accepts both Grx and Trx as an electron donor, whereas mammalian peroxiredoxins were shown to use only Trx or an

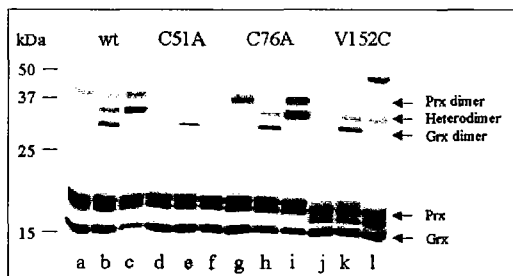

FIG. 5. Formation of heterodimers between poplar Prx and Grx. Nonreducing 14% SDS-PAGE showing each Prx incubated with each Grx in the presence of diamide. Lanes a-c, WT Prx; lanes d-f, Prx C51A; lanes g-i, Prx C76A; lanes j-l, Prx V152C. These Prxs were incubated with WT Grx (lanes a, d, g, and j), Grx C27S (lanes b, e, h, and k), or Grx C30S (lanes c, f, i, and l). Arrows indicate the position of the monomeric enzymes and the dimers.

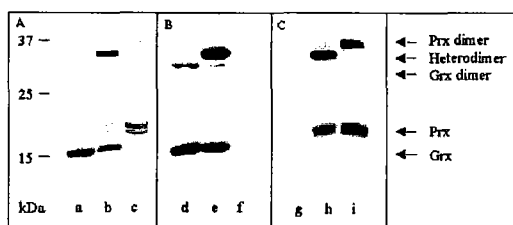

FIG. 6. Immunodetection of the heterodimers. A, Coomassie Blue staining of nonreducing 14% SDS-PAGE. Lane a, Grx C30S alone + diamide; lane b, Grx C30S + WT Prx + diamide; lane c, WT Prx alone + diamide. B, Western blot experiment with anti-Grx antibodies. C, Western blot experiment with anti-Prx antibodies. Lanes d-f and g-i correspond to lanes a-c described in A.

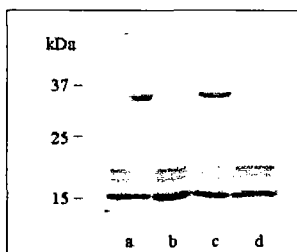

FIG. 7. Dissociation of the heterodimers by reductants. The heterodimers between Prx and Grx C56S were prepared in the presence of 1 mM diamide (lane a) and then tentatively reduced with 10 mM dithiothreitol (lane b), 20 mM glutathione (lane c), or 50 mM glutathione (lane d), always in the presence of diamide.

unidentified donor as a proton source (14, 18). The poplar enzyme studied in this report is clearly a homologue of human Prx V (14). Both proteins are monomeric and contain 162 amino acids. The major difference between the two enzymes is their cysteine content. The poplar Prx possesses two cysteines at positions 51 and 76. These residues are conserved in human Prx V, but there is an additional cysteine in position 152. This cysteine residue is present only in the mammalian sequences and not in the plant homologues of poplar Prx or the *C. boidinii* sequence (Fig. 1). Mutagenesis studies on human Prx V have shown that this protein belongs to a new class of Prxs (14). Site-directed mutagenesis has clearly shown that Cys-47 is the catalytic residue on this protein, similar to all other peroxiredoxins. The catalytic mechanism of human Prx V necessitates both Cys-47 and Cys-152 when the donor is thioredoxin or necessitates Cys-47 alone with dithiothreitol as a donor. Mutagenesis studies indicate that Cys-72 is not involved in the reactivity of this protein.

Given the strong similarity between human Prx V and poplar

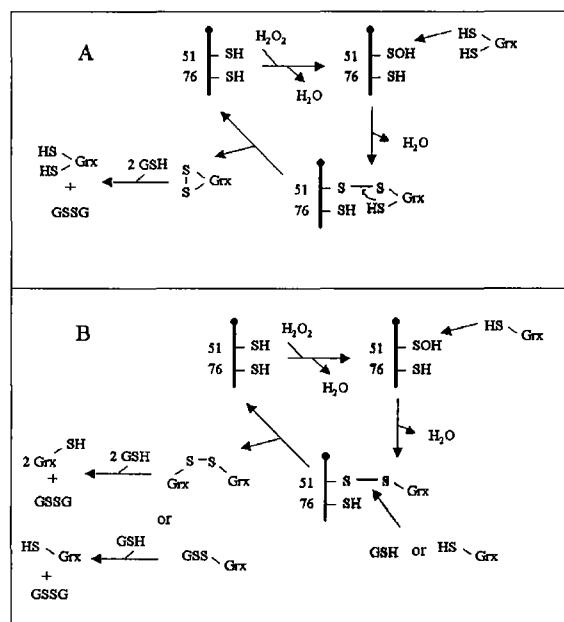

FIG. 8. Mechanisms for Grx-dependent Prx catalysis. Proposed catalytic mechanism of the WT Prx reduction supported by WT Grx (A) or by the mutant Grx C30S (B). Closed circles indicate the N terminus of Prx.

Prx and also the specificity of the plant enzyme (to use also Grx as a proton donor), it was of interest to examine the reasons for the unique properties of the plant protein. We have investigated this by a combination of site-directed mutagenesis, kinetic measurements, and the construction of covalently linked hybrid molecules between Prx and Grx. The results presented here indicate clearly that Cys-51 of Prx is the catalytic cysteine. The mutation of Cys-76 into an alanine does reduce the catalytic efficiency of the enzyme by approximately 75%, but nevertheless, the protein remains active with Grx as a proton donor, a behavior strikingly different from that of the C51A mutant, which is completely inactive. The biochemical data gathered in this study suggest that poplar Prx is a monomeric enzyme (very little dimer is present in the preparations analyzed by nonreducing SDS-PAGE irrespective of the conditions used for preparation of the protein). Moreover, the thiol titrations do not support the presence of a disulfide bridge between Cys-51 and Cys-76 on this protein. We postulate thus that the decrease in catalytic efficiency of the C76A mutant is linked to a modification of the microenvironment of the catalytic cysteine because of the introduction of the alanine residue in place of Cys-76. It is noteworthy that a slightly different mutation has been made in the case of human Prx V (C72S instead of C76A here), and this might be a reason for the different behavior of the plant mutant. Another line of evidence that Cys-76 is probably not involved in the redox mechanism of this Prx type is that this residue is absent in the two very closely related *O. sativa* and *C. boidinii* sequences (see Fig. 1). Moreover, a three-dimensional structure was recently published for the human Prx V (28). It shows that the sulfur atom of Cys-47 is 7.5 Å away from that of Cys-72, suggesting that the two residues are indeed not linked by a disulfide bridge unless there is an important conformational change.

The mutagenesis experiments presented here also provide experimental evidence for the Grx-dependent catalytic mechanism of poplar Prx. From the heterodimer experiments, it is clear that the two residues that interact between Prx and Grx are Cys-51 and Cys-27, respectively. The absence of het-

erodimer formation in the presence of the WT Grx is a clear indication that Cys-30 of Grx is the backup cysteine responsible for the breaking of the heterodisulfide. A scheme for the reaction of Prx in the presence of WT Grx is shown in Fig. 8A. As for the other Prx, the catalysis proceeds through the formation of a sulfenic acid on Cys-51. The latter is reduced, and a disulfide bond is formed with Cys-27 of Grx with the release of one water molecule. The heterodisulfide is then broken by Cys-30 of Grx, and the reoxidized Grx molecule is regenerated by reduced glutathione. Fig. 8B shows the alternative catalytic cycle in the presence of a monocysteine Grx (C30S). As in Fig. 8A, the sulfenic acid of Cys-51 is reduced via Cys-27 of Grx. The heterodimer is then broken by either glutathione or another monocysteine Grx molecule. The glutathionylated Grx or the dimeric Grx is then reduced via glutathione.

Given the rather high similarity between poplar Prx and human Prx V, it is rather surprising that the latter protein was not found to use Grx as a donor as well (14). However, there is one important difference between the human and the poplar enzyme: the presence of Cys-152, which participates in the formation of an intramolecular disulfide bridge in the human enzyme, and its absence in the plant protein. Our results clearly indicate that WT Prx and mutant C76A can both use Trx and Grx as donors. Both these enzymes, unlike the mammalian protein, lack Cys-152. When we engineered the plant protein and produced the V152C mutant that is similar to the mammalian protein, this enzyme conserved activity with Trx as a donor but lost its capacity to use Grx as a reductant. The maximal activity obtained with the Prx V152C mutant is similar to that described for human Prx V. The poplar protein has thus acquired a behavior similar to that of the mammalian protein. Because we could observe that Grx C27S is still able to bind to the V152C mutant but produces higher molecular mass complexes that are likely to contain two Grx molecules attached/monomer Prx, we postulate that the reason for the absence of catalytic activity of the V152C mutant with Grx is a due to a steric hindrance because of the fixation of the two Grx molecules.

It has been shown that ribonucleotide reductase cannot use monocysteine Grx as a proton donor. Other reactions catalyzed by Grx (dehydroascorbate, 2-hydroethylidisulfide reduction) require either a monocysteine Grx or the protein that contains two thiols (29). Clearly, both versions of Grx are able to promote the catalysis of Prx. On the other hand, the monocysteine mutant of thioredoxins is essentially inactive with the targets that have been characterized thus far (30). We have also generated a single cysteine mutant of poplar Trx h1 in which the noncatalytic cysteine is replaced by a serine (C42S), and we observed that it is unable to promote catalysis with any Prx (data not shown). Thus, Trx is also unable to function in a monothiol pathway in this system. This is a further indication that the monothiol pathway discovered with Grx is very specific for this type of protein. Interestingly, there are many naturally occurring monocysteine Grxs in plants. Based on these observations, it will be of very high interest to compare the relative efficiencies of the corresponding proteins for Prx catalysis. The identity of the ultimate physiological donor for poplar Prx is thus still an open question. It is noteworthy that several sequences in the data bases indicate the presence of fusion proteins between a close homologue of poplar Prx and Grx but not Trx (18, 22). In most of these sequences, the position of the two cysteines is conserved relative to poplar Prx. Based on the amino acid comparisons, it is relatively safe to assume that the

*Brassica* and *Arabidopsis* proteins should be able to use Grx as a donor as well. Whether this type is restricted to plants is still an open question.

Because the mutagenesis results suggest that the interaction sites for Grx and Trx are different on the plant Prx, it will be very interesting to map the areas of contact between the molecules, possibly by crystallizing the covalent complexes and solving its three-dimensional structure. The successful creation of disulfide-linked heterodimers between WT Prx and Trx h1 C42S should also help in this respect (data not shown). The solution of the three-dimensional structure of poplar Prx should also help us to understand why this protein accepts two donors, but human Prx V does not. The results obtained in this study suggest that Cys-152 is a critical residue for this property, but other domains of the proteins may be equally important as well.

*Acknowledgment*—We thank Dr. Francis Martin for valuable help and discussions.

#### REFERENCES

- Rhee, S. G., Kang, S. W., Netto, L. E., Seo, M. S., and Stadtman, E. R. (1999) *Biofactors* **10**, 207–209
- Halliwell, B., and Gutteridge, J. M. (1990) *Methods Enzymol.* **186**, 1–85
- Beckman, K. B., and Ames, B. N. (1997) *J. Biol. Chem.* **272**, 19633–19636
- Berlett, B. S., and Stadtman, E. R. (1997) *J. Biol. Chem.* **272**, 20313–20316
- Jin, D. Y., Chae, H. Z., Rhee, S. G., and Jeang, K. T. (1997) *J. Biol. Chem.* **272**, 30952–30961
- Kim, H., Lee, T. H., Park, E. S., Suh, J. M., Park, S. J., Chung, H. K., Kwon, O. Y., Kim, Y. K., Ro, H. K., and Shong, M. (2000) *J. Biol. Chem.* **275**, 18266–18270
- Zhou, Y., Kok, K. H., Chun, A. C., Wong, C. M., Wu, H. W., Lin, M. C., Fung, P. C., Kung, H., and Jin, D. Y. (2000) *Biochem. Biophys. Res. Commun.* **268**, 921–927
- Rhee, S. G., Kim, K. H., Chae, H. Z., Yim, M. B., Uchida, K., Netto, L. E., and Stadtman, E. R. (1994) *Ann. N. Y. Acad. Sci.* **738**, 86–92
- Chae, H. Z., Uhm, T. B., and Rhee, S. G. (1994) *Proc. Natl. Acad. Sci. U. S. A.* **91**, 7022–7026
- Kang, S. W., Baines, I. C., and Rhee, S. G. (1998) *J. Biol. Chem.* **273**, 6303–6311
- Pedrajas, J. R., Miranda-Vizuete, A., Javanmardy, N., Gustafsson, J. A., and Sproug, G. (2000) *J. Biol. Chem.* **275**, 16286–16301
- Lee, S. P., Hwang, Y. S., Kim, Y. J., Kwon, K. S., Kim, H. J., Kim, K., and Chae, H. Z. (2001) *J. Biol. Chem.* **276**, 29826–29832
- Knoops, B., Clippe, A., Bogard, C., Arsalane, K., Wattiez, R., Hermans, C., Duconseille, E., Falmagne, P., and Bernard, A. (1999) *J. Biol. Chem.* **274**, 30451–30458
- Seo, M. S., Kang, S. W., Kim, K., Baines, I. C., Lee, T. H., and Rhee, S. G. (2000) *J. Biol. Chem.* **275**, 20346–20354
- Jeong, W., Cha, M. K., and Kim, I. H. (2000) *J. Biol. Chem.* **275**, 2924–2930
- Kong, W., Shiota, S., Shi, Y., Nakayama, H., and Nakayama, K. (2000) *Biochem. J.* **351**, 107–114
- Chae, H. Z., Kim, H. J., Kang, S. W., and Rhee, S. G. (1999) *Diabetes Res. Clin. Pract.* **45**, 101–112
- Rouhier, N., Gelhaye, E., Sautière, P. E., Brun, A., Laurent, P., Tagu, D., Gerard, J., de Fay, E., Meyer, Y., and Jacquot, J. P. (2001) *Plant Physiol.* **127**, 1299–1309
- Choi, Y. O., Cheong, N. E., Lee, K. O., Jung, B. G., Hong, C. H., Jeong, J. H., Chi, Y. H., Kim, K., Cho, M. J., and Lee, S. Y. (1999) *Biochem. Biophys. Res. Commun.* **258**, 768–771
- Rouhier, N., Gelhaye, E., and Jacquot, J. P. (2002) *Prot. Expression Purif.* **24**, 234–241
- Behm, M., and Jacquot, J. P. (2000) *Plant Physiol. Biochem.* **38**, 363–369
- Vergauwen, B., Pauwels, F., Jacquemotte, F., Meyer, T. E., Cusanovich, M. A., Bartsch, R. G., and Van Beeumen J. J. (2001) *J. Biol. Chem.* **276**, 20890–20897
- Jacquot, J. P., Rivera-Madrid, R., Marinho, P., Kollarova, M., Le Marechal, P., Miginiac-Maslow, M., and Meyer, Y. (1994) *J. Mol. Biol.* **235**, 1357–1363
- Schenk, P. M., Baumann, S., Mattes, R., and Steinbiss, H. H. (1995) *BioTechniques* **19**, 196–200
- Laemmli, U. K. (1970) *Nature* **227**, 680–685
- Peshenko, I. V., and Shichi, H. (2001) *Free Radic. Biol. Med.* **31**, 292–303
- Verdoucq, L., Vignols, F., Jacquot, J. P., Chartier, Y., and Meyer, Y. (1999) *J. Biol. Chem.* **274**, 19714–19722
- Declercq, J. P., Evrard, C., Clippe, A., Stricht, D. V., Bernard, A., and Knoops, B. (2001) *J. Mol. Biol.* **311**, 751–759
- Qin, J., Yang, Y., Velyvis, A., and Gronenborn, A. (2000) *Antioxid. Redox Signal.* **2**, 827–840
- Goyer, A., Decottignies, P., Lemaire, S., Ruelland, E., Issakidis-Bourguet, E., Jacquot, J. P., and Miginiac-Maslow, M. (1999) *FEBS Lett.* **444**, 165–169
- Rouhier, N., Gelhaye, E., and Jacquot, J. P. (2002) *FEBS Lett.* **511**, 145–149

Article numéro 13 :

**Echalier A, Corbier C, Rouhier N, Jacquot JP, Aubry A. (2002)**

*Crystallization and preliminary X-ray data of a bifunctional peroxiredoxin from poplar.*

***Acta Crystallogr. D Biol. Crystallogr.* 58(Pt 9):1501-3.**

Parmi les 4 groupes distincts de Prx chez les plantes, aucune structure n'a été obtenue jusqu'à présent que ce soit par RMN ou cristallographie. Seules 9 structures de Prx ont été résolues. Aux 6 structures déjà décrites dans cet article, s'ajoutent maintenant une autre forme de la Prx V (code PDB 1HD2), une Ahpc de *Salmonella thyphimurium* (code PDB 1KYG) et une protéine de fusion d'*Haemophilus influenzae* entre des modules Grx et Prx (code PDB 1NM3). Deux formes de cristaux ont été obtenues pour la Prx sauvage et diffractent à 1.62Å et 2.48Å et une seule forme pour Prx V152C qui diffracte à 2.17Å. La structure de la Prx de type II a été déterminée par remplacement moléculaire par rapport à la structure de la Prx V humaine puisque les deux protéines possèdent une identité de séquence de 42% et sera présentée dans un prochain article.

Crystallization and preliminary X-ray data of a  
bifunctional peroxiredoxin from poplarAude Echalié,<sup>a</sup> Catherine  
Corbier,<sup>a</sup> Nicolas Rouhier,<sup>b</sup>  
Jean-Pierre Jacquot<sup>b</sup> and André  
Aubry<sup>a\*</sup><sup>a</sup>LCM3B, Groupe Biocristallographie,  
UMR 7036, UHP, Faculté des Sciences,  
54506 Vandoeuvre CEDEX, France, and<sup>b</sup>Interaction Arbres Microorganismes,  
UMR 1136 INRA UHP, Faculté des Sciences,  
54506 Vandoeuvre CEDEX, FranceCorrespondence e-mail:  
aubry@lcm3b.uhp-nancy.fr

Two variants (wild type and V152C mutant) of a bifunctional poplar peroxiredoxin have been overexpressed in *Escherichia coli* cells. The two recombinant enzymes were purified and crystallized using the hanging-drop vapour-diffusion technique. Data sets were collected to 1.62 and 2.48 Å resolution using X-ray synchrotron-source radiation from two crystal forms of wild-type peroxiredoxin which belonged to the monoclinic space group  $P2_1$  (with unit-cell parameters  $a = 59.26$ ,  $b = 68.80$ ,  $c = 75.71$  Å,  $\beta = 93.45^\circ$ ) and to the orthorhombic space group  $P2_12_12$  (with unit-cell parameters  $a = 64.70$ ,  $b = 130.73$ ,  $c = 35.59$  Å), respectively. Data were also collected to 2.17 Å resolution using a home X-ray source from a V152C peroxiredoxin crystal which belongs to the triclinic space group ( $P1$ ), with unit-cell parameters  $a = 36.65$ ,  $b = 41.53$ ,  $c = 58.06$  Å,  $\alpha = 70.52$ ,  $\beta = 93.45$ ,  $\gamma = 64.31^\circ$ . Phases have been obtained using molecular replacement with the structure of human peroxiredoxin V (PDB code 1hd2) as a search model. Refinement of the structures is in progress.

Received 11 April 2002  
Accepted 3 July 2002

## 1. Introduction

Peroxiredoxins (PRX) are non-haem peroxidases which catalyse the conversion of alkylhydroperoxides into the corresponding alcohol and water in the presence of an adequate electron/proton donor according to the equation

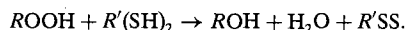

Peroxiredoxins are ubiquitous enzymes from bacteria to mammals and are generally overexpressed when the cells are subjected to oxidative stress, a condition where  $\text{H}_2\text{O}_2$  is produced in massive amounts (Kang, Chae *et al.*, 1998). They also play a role in apoptosis or in the regulation of transcription factors (Zhang *et al.*, 1997; Zhou *et al.*, 2000). As the proton donor is mostly the small ubiquitous protein thioredoxin, it has also often been called thioredoxin peroxidase. Other variants have been named AhpC and tryparedoxin peroxidase (Poole, 1996; Montemartini *et al.*, 1998). Several classes of peroxiredoxins can be differentiated based on their catalytic mechanisms and sequences. All the peroxiredoxins possess a conserved catalytic cysteine surrounded by conserved amino acids with the consensus sequence FT(P/F)(V/G/T)C(P/T/S). In the course of catalysis, this catalytic cysteine is transformed into a sulfenic acid which is regenerated into a thiol group, generally in the presence of thioredoxin as an electron donor (Kang, Baines *et al.*, 1998). In the so-called 2-Cys peroxiredoxins, catalysis proceeds

through the formation of either an intramolecular disulfide between the catalytic cysteine and another conserved cysteine or of an intermolecular disulfide between two head-to-tail peroxiredoxin monomers (Kong *et al.*, 2000). In another type, called the 1-Cys peroxiredoxins, only the catalytic cysteine is necessary and the thiol-regenerating system is either thioredoxin or an unidentified thiol component that can be replaced by dithiothreitol *in vitro* (Kang, Baines *et al.*, 1998; Pedrajas *et al.*, 2000). A third type, recently characterized in poplar (*Populus trichocarpa*), is an atypical 2-Cys peroxiredoxin which contains the conserved catalytic Cys and another Cys, the position of which is conserved in this third group. It differs however from the position of the second Cys of the 2-Cys peroxiredoxins and, in addition, it is not necessary for catalysis (Rouhier *et al.*, 2002). This protein is a bifunctional enzyme which can use thioredoxin as a proton donor but exhibits preference for a related protein, glutaredoxin, which is itself reduced by NADPH, glutathione reductase and glutathione, instead of NADPH and thioredoxin reductase as required for thioredoxin (Rouhier *et al.*, 2001).

In mammals, there are at least six genes coding for peroxiredoxin and the corresponding proteins play a prominent role in fighting oxidizing species, since they are produced at very high levels in several tissues (Seo *et al.*, 2000). Currently, six structures are known for peroxiredoxins: three are of human

## crystallization papers

proteins (PDB codes 1prx, 1h40, 1qmv), a fourth is a rat enzyme (PDB code 1qq2) and the two remaining are enzymes from *Criothidia fasciculata* (PDB code 1e2y) and *Mycobacterium tuberculosis* (PDB code 1knc) (Choi *et al.*, 1998; Hirotsu *et al.*, 1999; Alphey *et al.*, 2000; Schröder *et al.*, 2000; Declercq *et al.*, 2001). All are X-ray structures that are related to the thioredoxin fold. Although biochemical evidence indicates that peroxiredoxins function either as dimers or as monomers, several of these structures reveal that this enzyme can organize as decamers. Whether this is of physiological significance remains to be determined. Of the known structures, five correspond to 2-Cys peroxiredoxins and one to a 1-Cys peroxiredoxin.

The poplar enzyme recently identified and characterized is a very interesting protein because it is the only enzyme that is able to use glutaredoxin efficiently as an electron donor. It is thus likely that the sites of protein-protein interaction should be different on the poplar enzyme compared with the other peroxiredoxins described so far. In addition, unlike mammalian or bacterial enzymes, there are no structural data concerning peroxiredoxins in plants. Interestingly, we have also shown that the simple mutation V152C transforms the bifunctional peroxiredoxin into an enzyme which can use only thioredoxin as an electron donor (Rouhier *et al.*, 2002). In this respect, the poplar V152C mutant behaves more like its human homologue, peroxiredoxin V (Seo *et al.*, 2000; Rouhier *et al.*, 2002). We report here preliminary crystallization data concerning the wild type (WT) and the V152C mutant of poplar peroxiredoxin.

## 2. Results and discussion

### 2.1. Cloning, expression and purification

The cloning and expression of WT and V152C poplar peroxiredoxin is described in Rouhier *et al.* (2002). A high-yield expression was obtained by cloning the peroxiredoxin cDNA in expression plasmid pET-3d and cotransforming the BL21 *Escherichia coli* cells with the recombinant plasmid and the helper plasmid pSBET in order to compensate for the presence of unfavourable Arg codons. Typically, a single ampicillin- and kanamycin-resistant colony was selected and successively amplified in LB medium at 310 K to a final volume of 5 l. The protein production was promoted by the addition of 100  $\mu$ M IPTG for 3 h at 310 K. After breaking the cells by sonica-

**Table 1**  
Data-collection statistics.

Values in parentheses refer to the highest resolution shell.

Crystal	WT form I	WT form II	V152C
Space group	$P2_1$	$P2_12_12$	$P1$
Unit-cell parameters ( $\text{\AA}$ , $^\circ$ )	$a = 59.26$ , $b = 68.80$ , $c = 75.71$ , $\beta = 93.45$	$a = 64.70$ , $b = 30.73$ , $c = 35.59$ , $\alpha = \beta = \gamma = 90$	$a = 36.65$ , $b = 41.53$ , $c = 58.06$ , $\alpha = 70.52$ , $\beta = 84.68$ , $\gamma = 64.31$
Resolution ( $\text{\AA}$ )	1.62 (1.68–1.62)	2.48 (2.58–2.48)	2.17 (2.25–2.17)
Total reflections	294901	44949	73395
Unique reflections	79011	11600	13900
Completeness (%)	95.8 (83.5)	93.8 (90.4)	90.8 (79.5)
$R_{\text{merge}}^\dagger$	0.062 (0.19)	0.044 (0.11)	0.042 (0.11)
Mean $I/\sigma(I)^\ddagger$	15 (4)	10 (5)	10 (5)
Mosaicity	0.67	0.37	0.48
Crystal dimensions ( $\mu\text{m}$ )	$900 \times 300 \times 200$	$700 \times 100 \times 50$	$400 \times 300 \times 200$

$^\dagger R_{\text{merge}} = \sum(I_i - \langle I_i \rangle) / \sum I_i$ , where  $I$  is the intensity of observation  $I$  and  $\langle I \rangle$  is the mean intensity of the reflection.  $^\ddagger I/\sigma(I)$  is the intensity to background ratio.

tion, the protein was purified by a combination of ammonium sulfate precipitation, ACA 44 gel filtration and DEAE Sephacel chromatography. Typically, 300 mg of homogeneous protein were obtained and stored frozen in 1 ml aliquots in 30 mM Tris-HCl pH 8.0 containing 1 mM EDTA and 14 mM  $\beta$ -mercaptoethanol at a concentration of 15 mg ml<sup>-1</sup> at 248 K. The purity of the fractions was monitored by SDS-PAGE.

### 2.2. Crystallization

The initial screenings on the two PRX variants were carried out using the sparse-matrix sampling approach proposed by Jancarik & Kim (1991) and the hanging-drop vapour-diffusion method (McPherson, 1999). Drops were prepared for these initial crystallization experiments at 293 K by mixing 2  $\mu$ l of protein solution (15.6 mg ml<sup>-1</sup> WT PRX or 10 mg ml<sup>-1</sup> V152C PRX) and 2  $\mu$ l of reservoir solution (800  $\mu$ l). A first monoclinic crystal form (form I) was obtained at 293 K in 30% polyethyleneglycol (PEG) 4000, 0.1 M Tris-HCl pH 8.0 and 0.2 M Li<sub>2</sub>SO<sub>4</sub> for the WT protein but with a very low reproducibility. Although crystals were always obtained in this condition, it was extremely rare to obtain single crystals. Most of the time, the crystals were dendritic and not suitable for X-ray analysis. The use of these crystals to seed pre-equilibrated droplets allowed us to reproducibly obtain single crystals, but with poor diffraction pattern. This crystal condition was further optimized by an extensive search around this condition and by testing additives (Hampton Research). Very reproducible crystals, in an orthorhombic form, were finally obtained in 26% PEG 4000, 0.1 M Tris-HCl pH 8.0, 0.2 M Li<sub>2</sub>SO<sub>4</sub> and 0.02 M L-Cys at 293 K (with an equal volume of protein and precipitant agent in the

drops). Both crystal forms reached their final dimensions within a week. V152C PRX crystallized at 293 K in a similar condition (22.5% PEG 4000, 0.075 M Tris-HCl pH 8.0 and 0.15 M Li<sub>2</sub>SO<sub>4</sub>) to the WT PRX orthorhombic form but with a different ratio of protein to reservoir solution (3:1) in the drops and without reducing reagent. Reproducible mutant PRX crystals appeared within 5–6 d as thick plates.

### 2.3. Data collection and analysis

Data were collected from nitrogen flash-frozen crystals (100 K). Prior to this, the crystals were quickly soaked in a cryogenic buffer composed of the reservoir solution plus 20% glycerol and mounted in a nylon loop. Complete data sets were collected from the two different WT PRX forms on beamline DW32 at LURE ( $\lambda = 0.948 \text{ \AA}$ , Orsay France), whereas the V152C PRX data collection was performed on our home area detector (DIP2030) with a  $\Phi$  goniometer using Cu  $K\alpha$  radiation from a rotating-anode generator (Nonius BV, model FR591). Indexing, integration and merging of the data were carried out with the *HKL* suite (Otwinowski & Minor, 1996). The WT crystals (form I, obtained without seeding) belong to the monoclinic space group  $P2_1$ , with unit-cell parameters  $a = 59.26$ ,  $b = 68.80$ ,  $c = 75.71 \text{ \AA}$ ,  $\beta = 93.45^\circ$ . The crystal diffracted to 1.62  $\text{\AA}$ , with overall data completeness and  $I/\sigma(I)$  of 95.8% and 15, respectively, and values of 83.5% and 4, respectively, for the 1.68–1.62  $\text{\AA}$  shell. The  $R_{\text{merge}}$  of the data set was 0.062% overall and 0.19% for the 1.8–1.6  $\text{\AA}$  shell (Table 1). The WT PRX orthorhombic crystals (form II) diffracted to 2.48  $\text{\AA}$  and belong to space group  $P2_12_12$ , with unit-cell parameters  $a = 64.70$ ,  $b = 130.73$ ,  $c = 35.59 \text{ \AA}$  (Table 1). The Matthews coefficients  $V_M$  (Matthews,

1968) for the monoclinic and the orthorhombic forms were 2.22 and 2.17 Å<sup>3</sup> Da<sup>-1</sup>, respectively, which correspond to 42.4 and 41.1% solvent content, respectively, assuming four and two molecules per asymmetric unit. The mutant V152C PRX crystals belong to the triclinic space group (P1), with unit-cell parameters  $a = 36.65$ ,  $b = 41.53$ ,  $c = 58.06$  Å,  $\alpha = 70.52$ ,  $\beta = 93.45$ ,  $\gamma = 64.31^\circ$ . They diffracted to 2.17 Å resolution (Table 1). Assuming two molecules per asymmetric unit, the Matthews coefficient  $V_M$  is 2.10 Å<sup>3</sup> Da<sup>-1</sup> (39.2% solvent content).

#### 2.4. Phase determination

Molecular-replacement trials using the program *AMoRe* (Navaza, 1994) were performed with different modifications of human red blood cell PRX coordinates (PDB code 1qmv) or rat PRX coordinates (PDB code 1qq2) used as a model (28 and 25% identity, respectively), but were unsuccessful. Several attempts were also made to obtain either xenon or bromide derivatives. Finally, release of the coordinates of human peroxiredoxin V (PDB code 1hd2; 42% identity) allowed the determination of the phases by molecular replacement using *AMoRe*. The search model used is the

human PRX refined structure in which all the non-aligned residues (except Gly and Pro residues) between the poplar PRX and human PRX V have been replaced by alanines. Using data in the resolution range 12–4 Å and an integration radius of 25 Å, a clear solution was obtained with two molecules in the asymmetric unit for the WT orthorhombic form, with a correlation coefficient and an  $R$  factor of 44.9 and 44.5%, respectively (next best solution: 33.8 and 48.8%, respectively). Model building and refinement of these three structures is currently under way.

#### References

- Alphey, M. S., Bond, C. S., Tetaud, E., Fairlamb, A. H. & Hunter, W. N. (2000). *J. Mol. Biol.* **300**, 903–916.
- Choi, H. J., Kang, S. W., Yang, C. H., Rhee, S. G. & Ryu, S. E. (1998). *Nature Struct. Biol.* **5**, 400–406.
- Declercq, J. P., Evrard, C., Clippe, A., Stricht, D. V., Knoop, A. & Bernard, B. (2001). *J. Mol. Biol.* **311**, 751–759.
- Hirotsu, S., Abe, Y., Okada, K., Nagahara, N., Hori, H., Nishino, T. & Hakoshima, T. (1999). *Proc. Natl Acad. Sci. USA*, **96**, 12333–12338.
- Jancarik, J. & Kim, S.-H. (1991). *J. Appl. Cryst.* **24**, 409–411.
- Kang, S. W., Baines, I. C. & Rhee, S. G. (1998). *J. Biol. Chem.* **273**, 6303–6311.
- Kang, S. W., Chae, H. Z., Seo, M. S., Kim, K., Baines, I. C. & Rhee, S. G. (1998). *J. Biol. Chem.* **273**, 6297–6302.
- Kong, W., Shiota, S., Shi, Y., Nakayama, H. & Nakayama, K. (2000). *Biochem. J.* **351**, 107–114.
- McPherson, A. (1999). *Crystallization of Biological Macromolecules*. New York: Cold Spring Harbor Laboratory Press.
- Matthews, B. W. (1968). *J. Mol. Biol.* **33**, 491–497.
- Montemartini, M., Nogoceke, E., Singh, M., Steinert, P., Flohe, L. & Kalisz, H. M. (1998). *J. Biol. Chem.* **273**, 4864–4871.
- Navaza, J. (1994). *Acta Cryst.* **A50**, 157–163.
- Otwinowski, Z. & Minor, W. (1996). *Methods Enzymol.* **276**, 307–326.
- Pedrajas, J. R., Miranda-Vizuete, A., Javanmardy, N., Gustafsson, J. A. & Spyrou, G. (2000). *J. Biol. Chem.* **275**, 16296–16301.
- Poole, L. B. (1996). *Biochemistry*, **35**, 65–75.
- Rouhier, N., Gelhaye, E. & Jacquot, J. P. (2002). *J. Biol. Chem.* **277**, 13609–13614.
- Rouhier, N., Gelhaye, E., Sautière, P. E., Brun, A., Laurent, P., Tagu, D., de Fay, E., Meyer, Y. & Jacquot, J. P. (2001). *Plant Physiol.* **127**, 1299–1309.
- Schröder, E., Littlechild, J. A., Lebedev, A. A., Errington, N., Vagin, A. A. & Isupov, M. N. (2000). *Structure Fold. Des.* **8**, 605–615.
- Seo, M. S., Kang, S. W., Kim, K., Baines, I. C., Lee, T. H. & Rhee, S. G. (2000). *J. Biol. Chem.* **275**, 20346–20354.
- Zhang, P., Liu, B., Kang, S. W., Seo, M. S., Rhee, S. G. & Obeid, L. M. (1997). *J. Biol. Chem.* **272**, 30615–30618.
- Zhou, Y., Kok, K. H., Chun, A. C., Wong, C. M., Wu, H. W., Lin, M. C., Fung, P. C., Kung, H. & Jin, D. Y. (2000). *Biochem. Biophys. Res. Commun.* **268**, 921–927.

Article numéro 14 :

**Rouhier N, Gelhaye E, Corbier C, Jacquot JP.**

*Active site mutagenesis and phospholipid hydroperoxide reductase activity of type II poplar peroxiredoxin.*

***Physiol. Plant., accepté.***

Deux nouvelles mutations ont été effectuées sur la Prx de type II, en se basant sur un alignement de séquences des différents types de Prx existant et sur la structure d'une tryparédoxine peroxidase de *Crithidia fasciculata*. En effet, ces deux approches indiquent que la thréonine en position 48, la cystéine 51 et l'arginine 129 (numérotation de l'enzyme de peuplier) sont les trois seuls acides aminés conservés parmi toutes les séquences. Ainsi, les protéines recombinantes Prx T48V et R129Q ont été produites et purifiées et leur activité comparée à celle de la protéine sauvage. Ces deux mutants sont soit faiblement actifs ou totalement inactifs. Cette perte d'activité serait due plutôt à une perte de reconnaissance du substrat que du donneur d'électrons (Trx ou Grx) puisque ces protéines mutantes sont légèrement actives en présence CUOOH. Par ailleurs, cet article fait état pour la première fois d'une activité de réduction des phospholipide hydroperoxydes et plus précisément des phosphatidylcholine hydroperoxydes (PCOOH), pour une Prx de plante alors que cette activité était déjà décrite pour des Prx d'autres organismes. Cette activité de réduction des phospholipide hydroperoxydes vient d'être mise en évidence également pour les Prx à 2 cystéines (König *et al.*, 2003). D'un point de vue physiologique, cette activité est importante puisque les ROS vont notamment endommager les membranes des cellules par ces phénomènes de peroxydation des lipides.



# Active site mutagenesis and phospholipid hydroperoxide reductase activity of poplar type II peroxiredoxin

Nicolas Rouhier<sup>¶‡</sup>, Eric Gelhaye<sup>¶</sup>, Catherine Corbier\* and Jean Pierre Jacquot<sup>¶</sup>

<sup>¶</sup> UMR 1136 Interaction Arbres Microorganismes INRA-UHP. Université Henri Poincaré, Faculté des Sciences BP 239, 54506 Vandoeuvre Cedex France.

\* LCM3B, Groupe Biocristallographie, UMR 7036, UHP, Faculté des Sciences, 54506 Vandoeuvre Cedex, France.

Jacquot Jean Pierre

Unité mixte de recherche 1136 IaM INRA-UHP Université Henri Poincaré Faculté des Sciences BP 239, 54506 Vandoeuvre Cedex France.

Telephone : ++ 33 383684225, Email : j2p@scbiol.uhp-nancy.fr

## Abbreviations

CUOOH, cumene hydroperoxide; Grx, glutaredoxin; GSH, glutathione; GR, glutathione reductase; NTR, NADPH thioredoxin reductase; PCOOH, phosphatidylcholine hydroperoxide; PHGpx, phospholipid hydroperoxide glutathione peroxidase; Prx, peroxiredoxin; t-BOOH, tertiary butyl hydroperoxide; Trx, thioredoxin.

## **Abstract**

The nature of the active site and the substrate specificity of poplar type II peroxiredoxin, an enzyme which uses preferentially glutaredoxin as an electron donor, have been investigated in this study. The type II peroxiredoxin is able to use phospholipid hydroperoxide nearly as efficiently as hydrogen peroxide. Two of the hyper conserved amino acid residues in peroxiredoxins have been altered, by site-directed mutagenesis, generating the mutants T48V and R129Q. The two mutant proteins are inactive with hydrogen peroxide or tertiary butyl hydroperoxide as substrates. On the other hand, the mutant enzymes catalyze the degradation of cumene hydroperoxide with low efficiency. This suggests that the thiol-dependent regeneration process of the catalytic cysteine is not affected by the mutations and that all substrates are not accommodated identically in the active site.

## Introduction

Peroxiredoxins (Prx), also known as thiol peroxidases or thioredoxin peroxidases, are non heme proteins which catalyze the reduction of various hydroperoxides into the corresponding alcohol and water (Chae *et al.* 1994). In plants, four subclasses have been defined taking into account the subunit composition and the position of the conserved cysteine residues (Dietz *et al.* 2002, Rouhier and Jacquot 2002). The first subclass called 2-Cys Prx is a homodimeric chloroplastic enzyme where the two subunits are linked covalently via a disulfide bridge in the oxidized form (Cheong *et al.* 1999, Goyer *et al.* 2002, König *et al.* 2002). A second group is constituted by the so-called chloroplastic Prx Q enzyme, which functions as a monomer possessing an intramolecular disulfide bond (Kong *et al.* 2000). Another type is the 1-Cys Prx, monomeric enzymes essentially restricted to seeds, containing only one conserved catalytic cysteine (Stacy *et al.* 1996, Haslekas *et al.* 1998, Mowla *et al.* 2002). Finally, the fourth group is defined as type II Prx, an enzyme which has the peculiarity of using thioredoxin (Trx) (Choi *et al.* 1999), but also and with a better efficiency glutaredoxin (Grx) as electron donors (Rouhier *et al.* 2001). Another feature of this subclass is the existence of multiple isoforms localized in many subcellular compartments (Dietz *et al.* 2002, Horling *et al.* 2002). The catalytic cysteine which performs the attack of the peroxides is strictly conserved in all classes but the mechanisms of reduction depend on the subtype (Rouhier and Jacquot 2002). Sequence comparisons reveal that there are very few other conserved residues and two of those were demonstrated in trypanosomal enzymes as participating to the active site of Prx, a threonine in position 48 and an arginine in position 129 (poplar numbering in this work) (Montemartini *et al.* 1999).

It has been reported that peroxiredoxins catalyze the reduction of a wide variety of hydroperoxides, ranging from the most simple, hydrogen peroxide (H<sub>2</sub>O<sub>2</sub>), to more complex molecules such as cumene hydroperoxide (CUOOH), tertiary butyl hydroperoxide (t-BOOH) or phospholipid hydroperoxides (PCOOH) (Flohé *et al.* 2002, Manevitch *et al.* 2002). In addition, yeast, plant 2-Cys Prx, bovine Prx or bacterial counterparts known as AhpC catalyze the reduction of peroxynitrite *in vitro* and *in vivo* (Chen *et al.* 1998, Bryk *et al.* 2000, Peschenko and Schichi 2001, Wong *et al.* 2002, Sakamoto *et al.* 2003). Moreover, a Prx from *Leishmania chagasi* was also shown to perform hydroxyl radical detoxication (Barr *et al.* 2001).

We have earlier described a type II Prx from poplar and detailed its molecular interactions with the two alternative donors, Trx and Grx (Rouhier *et al.* 2002a). Moreover,

we have shown that poplar type II Prx is able to catalyze the reduction of various hydroperoxides with similar efficiency. We present here new data concerning the catalytic mechanism and substrate specificity of this protein, two domains which have not been extensively explored for plant enzymes.

## Materials and Methods

### Plasmids, strains and chemicals

The *Escherichia coli* strains used throughout this study were DH5 $\alpha$  for cloning experiments and BL21(DE3) for protein expression. The construction of the plasmids and the purification of the recombinant wild type (WT) Prx and Grx are described in (Rouhier *et al.* 2001, Rouhier *et al.*, 2002b). All chemicals and matrices used were of the highest grade and either from Sigma chemical company or Amersham Pharmacia Biotech.

### Construction of the mutagenized plasmids

The T48V and R129Q mutations were introduced by PCR using a combination of cloning and mutagenic oligonucleotides following the methods previously described in (Rouhier *et al.* 2002a). The mutagenic oligonucleotides have the following sequences :

T48V forward : 5' GTTCCCGGGGCCTTCG**T**CCCCACCTGCAGCTTG 3'

T48V reverse : 5' CAAGCTGCAGGTGGGGACGAAGGCCCCCGGGAAC 3'

R129Q forward 5' GGCACACGTTCTAGGCAGTTTGCTCTCTTGGTT 3'

R129Q reverse 5' AACCAAGAGAGCAA**A**CTGCCTAGAACGTGTGCC 3'

The mutagenic bases are in bold characters. The resulting plasmids were called pET Prx T48V and pET Prx R129Q. The expression of the recombinant proteins was performed in the presence of the helper plasmid pSBET as described in (Rouhier *et al.* 2002b). The purification of the mutant proteins was performed following the same procedure as for the WT enzyme, using a combination of ammonium sulfate precipitation, ACA 44 gel filtration and anion exchange chromatography. The concentration of the recombinant mutated proteins was estimated from their UV absorption using an extinction coefficient of 13490 M<sup>-1</sup> cm<sup>-1</sup>. The proteins were stored at -20°C in 30 mM Tris-HCl pH 8.0, 1 mM EDTA.

### Phospholipid hydroperoxide synthesis and purification

The synthesis of phosphatidylcholine hydroperoxide was realized in the presence of soybean type IV lipoxygenase as described in (Maiorino *et al.* 1990). Briefly, in a 2.5 mL reaction mixture containing 450 mM sodium borate pH 9.0 and 250 mM sodium deoxycholate, 593  $\mu$ g of phosphatidylcholine were incubated in the presence of 100  $\mu$ g of

type IV soybean lipoxygenase (36000 units) for two hours at room temperature with continuous shaking. The purification of PCOOH was then performed using Sep pak C18 columns from Waters using 100% methanol as an eluent. The concentration of PCOOH was estimated by a colorimetric reaction using the ferrous oxidation of xylenol orange reagent (FOX 2) by reference to a calibration curve realized with known H<sub>2</sub>O<sub>2</sub> concentrations (Wolff 1994). PCOOH was kept frozen at -20°C at a concentration of 1.7 mM.

### ***In vitro* hydroperoxide reduction by type II poplar Prx**

The H<sub>2</sub>O<sub>2</sub>, t-BOOH or CUOOH (250 μM) reduction were measured in a coupled reaction by following the oxidation of NADPH at 340 nm via NADPH/GR/GSH/Grx or NADPH/NTR/Trx in a 500 μL reaction medium at 30°C as described in (Rouhier *et al.* 2002a). A slight modification is the addition of 15 μL of 20% Triton X-100 for the measurement of PCOOH reduction (250 μM unless otherwise indicated) by recombinant type II Prx. A second assay consists in the time course measurement of the disappearance of PCOOH and other hydroperoxides using the FOX 2 or FOX 1 reagents respectively. The reaction medium (50 to 300 μL) had the following composition : 50 mM Tris HCl pH 8.0, 500 μM DTT, 250 μM PCOOH and varying amounts of Prx, between 0 to 3 μM. The reaction was started by adding PCOOH after one minute incubation at ambient temperature. For each time point, 50 μL of the reaction mixture were added to 950 μL FOX 2 reagent. The absorbance at 560 nm was read after one hour of incubation. All kinetics were repeated three times with two different enzyme preparations and the indicated values represent the average of the three measurements. The percentages presented in Table I are computed from the kcat values obtained for each enzyme.

## Results

### Prx sequence analysis and nature of the active site

When aligning the poplar type II Prx sequence with homologous enzymes from different sources (mammals, yeast, bacteria, trypanosoma), seven amino acid residues appear to be very conserved, P44, T48, C51, S78, D103, G122 and R129 (poplar numbering). If additional sequences are taken into account, out of those seven residues, only three amino acids remain strictly conserved, the catalytic cysteine, C51, one threonine, T48, and one arginine, R129 (data not shown). These properties suggest that T48 and R129 are likely to play an important role in catalysis as demonstrated in the case of trypanosomal enzymes (Montemartini *et al.* 1999, Flohé *et al.* 2002).

We have recently obtained crystals of poplar type II Prx that diffract to 1.6Å (Echalier *et al.* 2002) and solved the 3D structure of the protein (unpublished data). The structure confirms that the threonine and arginine residues are indeed in close proximity to the cysteine of the active site. Fig. 1 shows a blow up of the active site region of the poplar enzyme with the positioning of the three above mentioned residues. The partial structure presented here, fits well the hypothesis of the catalytic triad. The positions of two additional side chains which are more distant from the active site (W88 and C76) are also shown in Fig. 1. Cys76, which is the second cysteine of type II Prx, is dispensable for activity (Rouhier *et al.* 2002) and W88 is a conserved aromatic residue found also in the *Leishmania donovani* structure (Flohé *et al.* 2002).

### Active site mutagenesis

Thus, despite the low sequence identity (20%) between the poplar and the *Leishmania* enzymes, these data suggest a common catalytic mechanism for all peroxiredoxins. In order to confirm that T48 and R129 are indeed implicated in the catalysis of type II Prx, site-directed mutagenesis was performed to create the two single mutants, T48V, in which the OH group is removed, and R129Q where the positive charge is replaced by a non charged side chain. Fig. 2 shows the electrophoretic behavior of the various protein preparations generated. As observed before, despite being highly homogeneous, all preparations present a polypeptide doublet with a molecular mass of *ca* 17 kDa irrespective of the reducing conditions (Rouhier *et al.* 2001). The 3D structure indicates that the C-terminus is complete and N-terminal sequencing shows that all amino acids are present and no cleavage of the polypeptide occurred, except for a partial processing of the initial methionine which could perhaps explain

the presence of the doublet (data not shown). In addition, mass analysis suggests that no post-translational modification occurred in *E. coli* (data not shown). In oxidizing conditions, no evidence for a dimer was observed, indicating that the proteins do not contain an intermolecular disulfide bridge irrespective of the nature of the mutations.

### **Catalytic efficiencies of the WT and mutant enzymes**

The catalytic activities of the WT and of the mutated enzymes were first determined by using a coupled system in which the reduction of peroxides is coupled to NADPH oxidation *via* the Grx system. Table I shows the relative efficiencies of the WT and mutant peroxiredoxins, using various hydroperoxides as substrates. The T48V and R129Q mutants are marginally active with no more than 4% of the activity of the WT protein, when using H<sub>2</sub>O<sub>2</sub> or t-BOOH. Likewise, with CUOOH as a substrate, the activities of the mutants are depressed, but they retain a higher level of activity compared to the WT enzyme (7.8 and 16.3%). It should be mentioned that CUOOH does not behave as the two other substrates since the reaction catalysed by the WT enzyme is quickly inhibited, but the rates remain linear with the mutants. With the two other substrates the reactions are linear as a function of time whatever the enzyme used (data not shown).

The catalytic impairment of the mutants was confirmed by using a different activity measurement that relies on the direct determination of the remaining peroxides (Fig. 3). As observed in the coupled assay, the T48V and R129Q mutations resulted in catalysts that were essentially inactive or severely impaired with H<sub>2</sub>O<sub>2</sub> and t-BOOH. The results with CUOOH were not as clear cut as the mutants were more active than the WT enzyme. The discrepancy between this result and the one obtained using the coupled assay results from the above mentioned inhibition of the WT enzyme in the presence of CUOOH that occurs after *ca* 20 sec catalysis and the selected time of analysis in this second experiment (3 minutes).

We have also studied whether poplar type II Prx can use an additional substrate of physiological importance, phospholipid hydroperoxides. The direct determination of remaining PCOOH by FOX 2 after catalysis in the presence of the WT type II Prx and DTT is shown in Fig. 4. PCOOH is obviously a substrate of the enzyme, and the rate and extent of its removal is directly proportional to the concentration of enzyme present. The time course of PCOOH reduction indicates that the reaction, is complete after 45 seconds incubation in the presence of 500 μM DTT and 3 μM Prx. When the Prx concentration is lowered, the catalytic rates are reduced accordingly. DTT alone did not induce any noticeable degradation of PCOOH. Fig. 5 presents a plot showing the reaction rate as a function of PCOOH



concentration using the coupled assay. The reaction saturates at a PCOOH concentration of *ca* 50  $\mu\text{M}$ . These data indicate that the  $K_m$  for PCOOH is 23  $\mu\text{M}$ .

## Discussion

In plants as in other biological organisms, ROS can be extremely damaging for biological macromolecules and especially for phospholipids. It is often observed that the peroxidation of the membrane lipids leads to the destruction of those barriers and ultimately to the death of the cells. In order to fight these disastrous effects, several enzymes are able to reduce lipid hydroperoxides. Prominent among those, are the phospholipid hydroperoxide glutathione peroxidases (PHGpx) which are more efficient with phospholipid hydroperoxides than with other hydroperoxides (Maiorino *et al.* 1990). For some of the plant enzymes, homologous to mammalian PHGpx, glutathione is a poor donor which can be replaced more efficiently by Trx (Herbette *et al.* 2002, Jung *et al.* 2002). Surprisingly, it has been reported that the enzymes from *Lycopersicon esculentum* and *Heliantus annuus* exhibit catalytic activity with H<sub>2</sub>O<sub>2</sub> only when Trx was used as a donor (Herbette *et al.* 2002). This type of PHGpx could thus constitute a fifth type of peroxiredoxin unrecognized so far.

It has also been shown that mammalian, bacterial or trypanosomal peroxiredoxins can reduce phospholipid hydroperoxides (Maiorino *et al.* 1990, Hillas *et al.* 1997, Nogoceke *et al.* 1997). A recent report indicates that this is also true for barley 2-Cys Prx, which exhibits a low catalytic turnover with linoleic acid hydroperoxide and phosphatidylcholine dilinoleyl hydroperoxide, but this has not been shown for other plant enzymes yet (König *et al.* 2003). The data generated in this study indicate that type II Prx also possesses this additional function. This observation is further supported by the relatively good efficiency of this enzyme with PCOOH as kcat values are 2.6 s<sup>-1</sup> (H<sub>2</sub>O<sub>2</sub>), 2.1 s<sup>-1</sup> (PCOOH), 1.5 s<sup>-1</sup> (t-BOOH) and 0.89 s<sup>-1</sup> (CUOOH). The kcat values recorded for type II Prx with H<sub>2</sub>O<sub>2</sub> are very similar to those obtained with human Prx V, a mammalian homolog (Seo *et al.* 2001). From the data presented on tryparedoxin peroxidase from *Crithidia fasciculata* and on phospholipid hydroperoxide glutathione peroxidase from *Helianthus annuus*, catalytic efficiencies can be computed (Nogoceke *et al.* 1997, Herbette *et al.* 2002). The values of kcat/Km oscillate between 4X10<sup>3</sup> and 4X10<sup>4</sup> M<sup>-1</sup>.sec<sup>-1</sup>. The poplar type II Prx possesses a catalytic efficiency of 8X10<sup>4</sup> M<sup>-1</sup>.sec<sup>-1</sup> using PCOOH as a substrate, which indicates that it is quite a good catalyst for this reaction.

As the hydroperoxides used in this study display varied structures, it was of interest to investigate the nature of the active site of type II Prx. Through site-directed mutagenesis, we have obtained evidence that the type II Prx active site is indeed very similar to the active sites present in other peroxiredoxins, consisting of a catalytic triad formed by the catalytic

cysteine, a threonine and an arginine in conserved positions (Wood *et al.* 2003). The Thr and Arg residues are likely to play a role in increasing the reactivity of the catalytic cysteine, by stabilizing the thiolate form of the cysteine, maybe by lowering the pKa of the peroxidatic cysteine. The molecular mutants where the hydroxyl group of T48 or the guanidyl group of R129 are removed, are essentially inactive with t-BOOH and H<sub>2</sub>O<sub>2</sub> as a substrate whatever the electron donor used, DTT (Fig. 3), Grx (Table I) or Trx (data not shown). On the other hand, the mutants exhibit low activity with CUOOH as a substrate. This suggests that the mutations really affect the active site structure and reactivity but not the regeneration of the enzyme by thiols since the mutants keep some activity with one of the substrates. Also, at that point it is not entirely clear what the preferred substrate of type II Prx is, since all tested peroxides can serve for catalysis. As phospholipid hydroperoxides have extremely varied structures, it will be of interest to test whether there is a specificity in this new class of substrates for type II Prx.

## References

Barr SD, Gedamu L (2001) Cloning and characterization of three differentially expressed peroxidoxin genes from *Leishmania chagasi*. Evidence for an enzymatic detoxification of hydroxyl radicals. *J Biol Chem* 276: 34279-34287

Bryk R, Griffin P, Nathan C (2000) Peroxynitrite reductase activity of bacterial peroxiredoxins. *Nature* 407: 211-215

Chae HZ, Uhm TB, Rhee SG (1994) Dimerization of thiol-specific antioxidant and the essential role of cysteine 47. *Proc Natl Acad Sci U S A* 91: 7022-7026

Chen L, Xie QW, Nathan C (1998) Alkyl hydroperoxide reductase subunit C (AhpC) protects bacterial and human cells against reactive nitrogen intermediates. *Mol Cell* 1: 795-805

Cheong NE, Choi YO, Lee KO, Kim WY, Jung BG, Chi YH, Jeong JS, Kim K, Cho MJ, Lee SY (1999) Molecular cloning, expression, and functional characterization of a 2Cys-peroxiredoxin in *Chinese cabbage*. *Plant Mol Biol* 40: 825-834

Choi YO, Cheong NE, Lee KO, Jung BG, Hong CH, Jeong JH, Chi YH, Kim K, Cho MJ, Lee SY (1999) Cloning and expression of a new isotype of the peroxiredoxin gene of *Chinese cabbage* and its comparison to 2Cys-peroxiredoxin isolated from the same plant. *Biochem Biophys Res Commun* 258: 768-771

Dietz KJ, Horling F, König J, Baier M (2002) The function of the chloroplast 2-cysteine peroxiredoxin in peroxide detoxification and its regulation. *J Exp Bot* 53: 1321-1329

Echalier A, Corbier C, Rouhier N, Jacquot JP, Aubry A (2002) Crystallization and preliminary X-ray data of a bifunctional peroxiredoxin from poplar. *Acta Crystallogr D Biol Crystallogr* 58: 1501-1503

Flohé L, Budde H, Bruns K, Castro H, Clos J, Hofmann B, Kansal-Kalavar S, Krumme D, Menge U, Plank-Schumacher K, Sztajer H, Wissing J, Wylegalla C, Hecht HJ (2002)

Tryparedoxin peroxidase of *Leishmania donovani*: molecular cloning, heterologous expression, specificity, and catalytic mechanism. Arch Biochem Biophys 397: 324-335

Goyer A, Haslekas C, Miginiac-Maslow M, Klein U, Le Marechal P, Jacquot JP, Decottignies P (2002) Isolation and characterization of a thioredoxin-dependent peroxidase from *Chlamydomonas reinhardtii*. Eur J Biochem 269: 272-282

Haslekas C, Stacy RA, Nygaard V, Culianez-Macia FA, Aalen RB (1998) The expression of a peroxiredoxin antioxidant gene, AtPer1, in *Arabidopsis thaliana* is seed-specific and related to dormancy. Plant Mol Biol 36: 833-845

Herbette S, Lenne C, Leblanc N, Julien JL, Drevet JR, Roeckel-Drevet P (2002) Two GPX-like proteins from *Lycopersicon esculentum* and *Helianthus annuus* are antioxidant enzymes with phospholipid hydroperoxide glutathione peroxidase and thioredoxin peroxidase activities. Eur J Biochem 269: 2414-2420

Hillas PJ, del Alba FS, Oyarzabal J, Wilks A, Ortiz De Montellano PR (2000) The AhpC and AhpD antioxidant defense system of *Mycobacterium tuberculosis*. J Biol Chem 275: 18801-18809

Hofmann B, Hecht HJ, Flohe L (2002) Peroxiredoxins. Biol Chem 383: 347-364

Horling F, König J, Dietz KJ (2002) Type II peroxiredoxin C, a member of the peroxiredoxin family of *Arabidopsis thaliana*: its expression and activity in comparison with other peroxiredoxins Plant Physiol Biochem 40: 491-499

Jung BG, Lee KO, Lee SS, Chi YH, Jang HH, Kang SS, Lee K, Lim D, Yoon SC, Yun DJ, Inoue Y, Cho MJ, Lee SY (2002) A *Chinese cabbage* cDNA with high sequence identity to phospholipid hydroperoxide glutathione peroxidases encodes a novel isoform of thioredoxin-dependent peroxidase. J Biol Chem 277: 12572-12578

König J, Baier M, Horling F, Kahmann U, Harris G, Schurmann P, Dietz KJ (2002) The plant-specific function of 2-Cys peroxiredoxin-mediated detoxification of peroxides in the redox-hierarchy of photosynthetic electron flux. *Proc Natl Acad Sci U S A* 99: 5738-5743

König J, Lotte K, Plessow R, Brockhinke A, Baier M, Dietz KJ (2003) Reaction mechanism of plant 2-Cys peroxiredoxin: Role of the C-terminus and the quaternary structure. *J Biol Chem*, in press

Kong W, Shiota S, Shi Y, Nakayama H, Nakayama K (2000) A novel peroxiredoxin of the plant *Sedum lineare* is a homologue of *Escherichia coli* bacterioferritin co-migratory protein (Bcp). *Biochem J* 351: 107-114

Maiorino M, Gregolin C, Ursini F (1990) Phospholipid hydroperoxide glutathione peroxidase. *Methods Enzymol* 186: 448-457

Manevich Y, Sweitzer T, Pak JH, Feinstein SI, Muzykantov V, Fisher AB (2002) 1-Cys peroxiredoxin overexpression protects cells against phospholipid peroxidation-mediated membrane damage. *Proc Natl Acad Sci U S A* 99: 11599-11604

Montemartini M, Kalisz HM, Hecht HJ, Steinert P, Flohe L (1999) Activation of active-site cysteine residues in the peroxiredoxin-type trypanothione peroxidase of *Crithidia fasciculata*. *Eur J Biochem* 264: 516-524

Mowla SB, Thomson JA, Farrant JM, Mundree SG (2002) A novel stress-inducible antioxidant enzyme identified from the resurrection plant *Xerophyta viscosa* Baker. *Planta* 15: 716-726

Nogoceke E, Gommel DU, Kiess M, Kalisz HM, Flohe L (1997) A unique cascade of oxidoreductases catalyses trypanothione-mediated peroxide metabolism in *Crithidia fasciculata*. *Biol Chem* 378: 827-836

Peshenko IV, Shichi H (2001) Oxidation of active center cysteine of bovine 1-Cys peroxiredoxin to the cysteine sulfenic acid form by peroxide and peroxy nitrite. *Free Radic Biol Med* 31: 292-303

Rouhier N, Gelhaye E, Sautière PE, Brun A, Laurent P, Tagu D, de Fay E, Meyer Y, Jacquot JP (2001) Isolation and characterization of a new peroxiredoxin from poplar sieve tubes that uses either glutaredoxin or thioredoxin as a proton donor. *Plant Physiol* 127: 1299-1309

Rouhier N, Gelhaye E, Jacquot JP (2002a) Glutaredoxin-dependent peroxiredoxin from poplar. Protein-protein interaction and catalytic mechanism. *J Biol Chem* 277: 13609-13614

Rouhier N, Gelhaye E, Sautiere PE, Jacquot JP (2002b) Enhancement of poplar glutaredoxin expression by optimization of the cDNA sequence. *Protein Expr Purif* 24: 234-241

Rouhier N, Jacquot JP (2002) Plant peroxiredoxins: alternative hydroperoxide scavenging enzymes. *Photosynth Res* 74: 259-268

Sakamoto A, Tsukamoto S, Yamamoto H, Ueda-Hashimoto M, Takahashi M, Suzuki H, Morikawa H (2003) Functional complementation in yeast reveals a protective role of chloroplast 2-Cys peroxiredoxin against reactive nitrogen species. *Plant J* 33: 841-851

Seo MS, Kang SW, Kim K, Baines IC, Lee TH, Rhee SG (2000) Identification of a new type of mammalian peroxiredoxin that forms an intramolecular disulfide as a reaction intermediate. *J Biol Chem* 275: 20346-20354

Stacy RA, Munthe E, Steinum T, Sharma B, Aalen RB (1996) A peroxiredoxin antioxidant is encoded by a dormancy-related gene, *Per1*, expressed during late development in the aleurone and embryo of barley grains. *Plant Mol Biol* 31: 1205-1216

Wolff SP (1994) Ferrous ion oxidation of ferric ion indicator xylenol orange for measurement of hydroperoxides. *Methods Enzymol* 233: 182-189

Wood ZA, Schroder E, Robin Harris J, Poole LB (2003) Structure, mechanism and regulation of peroxiredoxins. *Trends Biochem Sci* 28: 32-40

Wong CM, Zhou Y, Ng RW, Kung Hf HF, Jin DY (2002) Cooperation of yeast peroxiredoxins Tsa1p and Tsa2p in the cellular defense against oxidative and nitrosative stress. *J Biol Chem* 277: 5385-5394



## Figure legends

Fig. 1. Reaction center of poplar type II Prx.

The figure was generated using PyMOL (Delano W, <http://www.pymol.org>). The side chains of the catalytic triad that includes Thr48, Cys51 and Arg129 are shown in sticks with a ribbon rendering of the closeby secondary structural units. The threonine and cysteine residues are located respectively close to or in helix  $\alpha$ 2 and the arginine in the penultimate strand  $\beta$ 9. The additional cysteine (Cys76 of  $\beta$ 4) and the conserved residue Trp88 of helix  $\alpha$ 3 are also shown.

Fig. 2. SDS PAGE analysis of the recombinant type II peroxiredoxins.

SDS PAGE 15 % showing WT type II Prx (lanes a and d) and mutants T48V (lanes b and e) and R129Q (lanes c and f) in reducing conditions (700 mM  $\beta$ -mercaptoethanol, lanes a, b, c) and in non reducing conditions (lanes d, e, f). The molecular weight marker (lane M) (15, 20, 25, 37, 50, 75 kDa) is the Precision Plus Protein Unstained Standard form BIORAD.

Fig. 3. DTT dependent activity of type II Prx WT, T48V, R129Q.

The reaction were carried out with 2  $\mu$ M of Prx in the presence of 500  $\mu$ M DTT and 500  $\mu$ M hydroperoxides. All experiments are triplicates.

Fig. 4. Time course of phosphatidylcholine hydroperoxide reduction.

The reduction of PCOOH by WT type II Prx was measured by following the disappearance of 250  $\mu$ M PCOOH using 500  $\mu$ M DTT as a reductant and the FOX 2 reagent. Close circles : minus Prx, open circles : 1  $\mu$ M Prx, close triangles : 2  $\mu$ M Prx, open triangles : 3  $\mu$ M Prx.

Fig. 5. Kinetics of hydroperoxide reduction as a function of the substrate concentration.

The 500  $\mu$ L reaction mixture contained 150  $\mu$ M NADPH, 500  $\mu$ M GSH, 0.5 unit GR, 2  $\mu$ M poplar Grx, 1  $\mu$ M type II Prx and various concentrations of PCOOH, ranging from 25 to 250  $\mu$ M. The catalytic activity was expressed as  $\mu$ moles of oxidized NADPH per min per mg of protein.

	H <sub>2</sub> O <sub>2</sub>	t-BOOH	CUOOH	PCOOH
Prx WT	100 (2.6 s <sup>-1</sup> )	100 (1.5 s <sup>-1</sup> )	100 (0.9 s <sup>-1</sup> )	100 (2.1 s <sup>-1</sup> )
Prx T48V	2.3	0.4	16.3	2.2
Prx R129Q	0.3	3.6	7.8	0

Table I: Relative activity of WT Prx and T48V or R129Q mutants with various substrates. 100% activity corresponds to the WT enzyme activity with each substrate. In brackets are indicated the kcat (s<sup>-1</sup>) for each substrate in the enzymatic coupled assay.

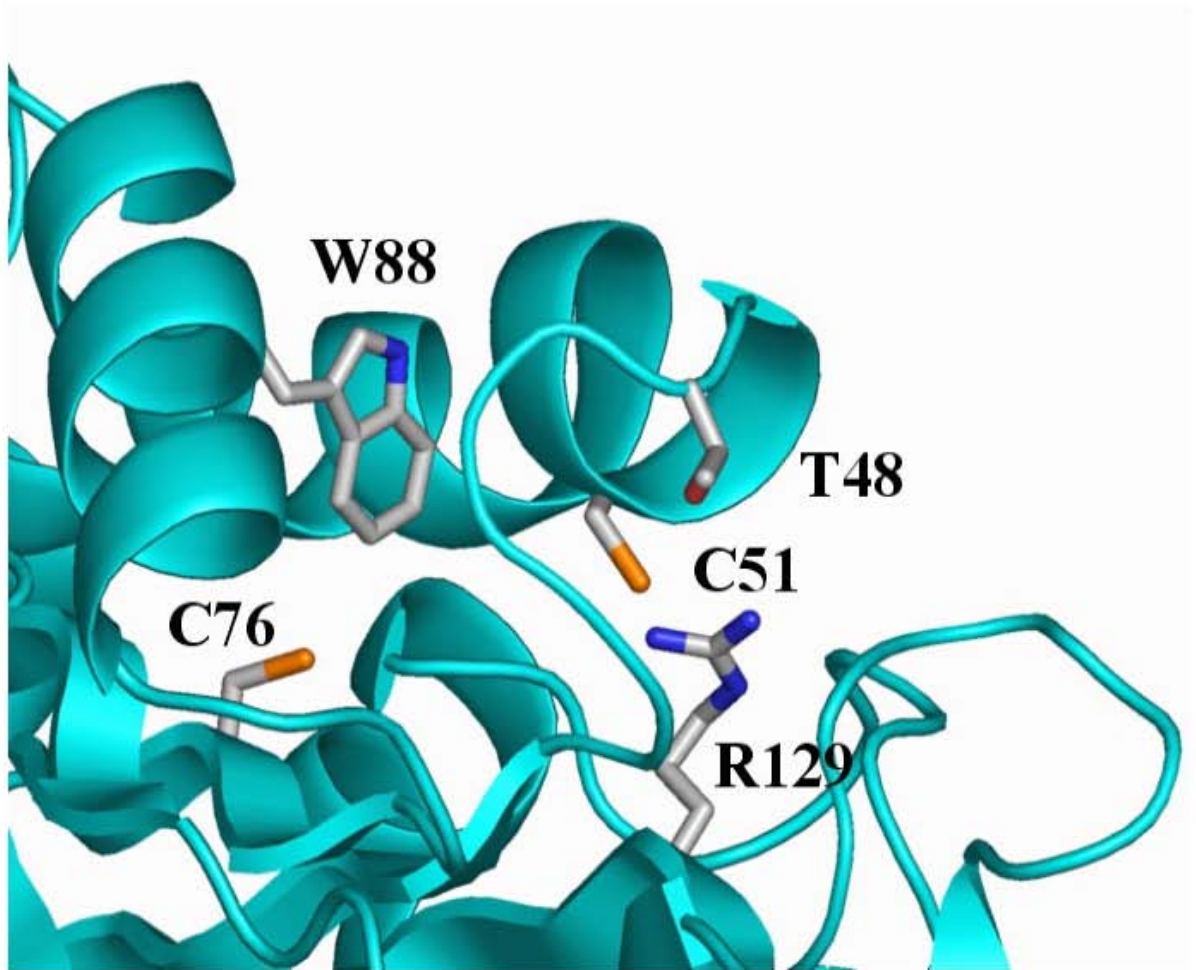

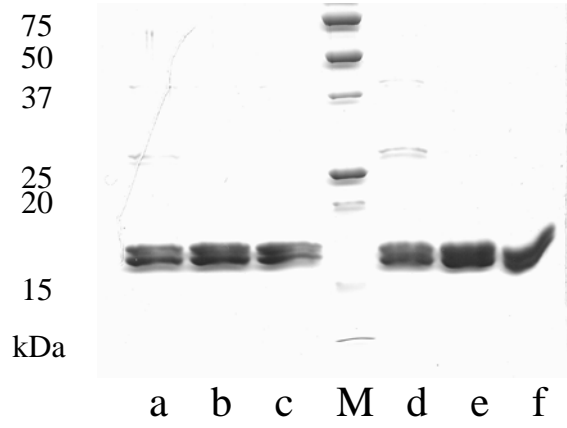

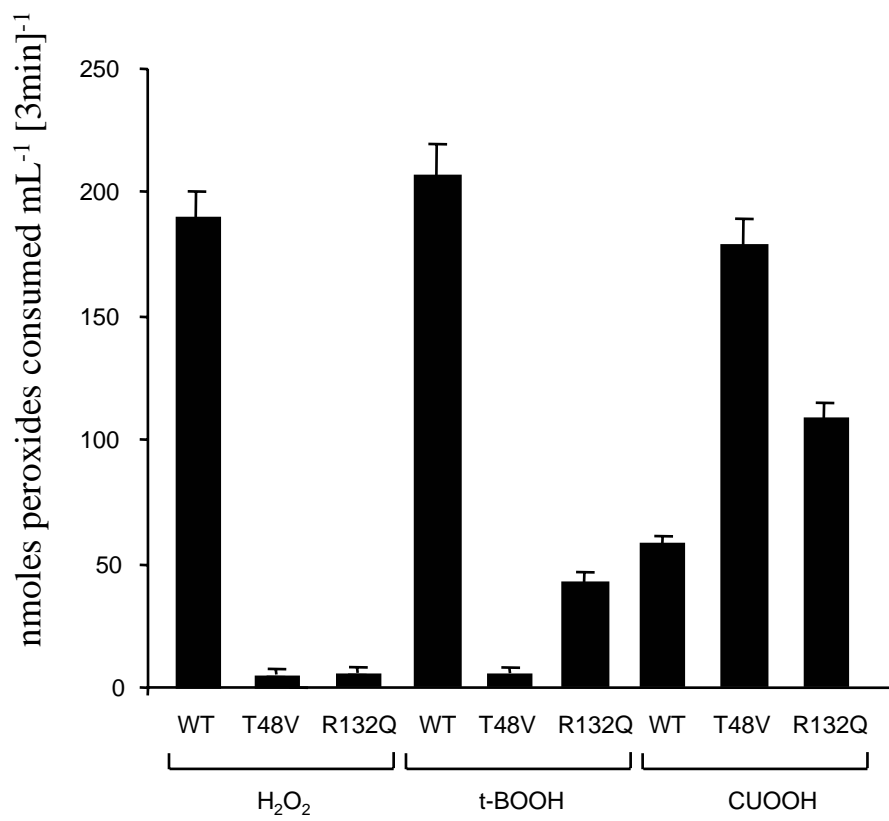

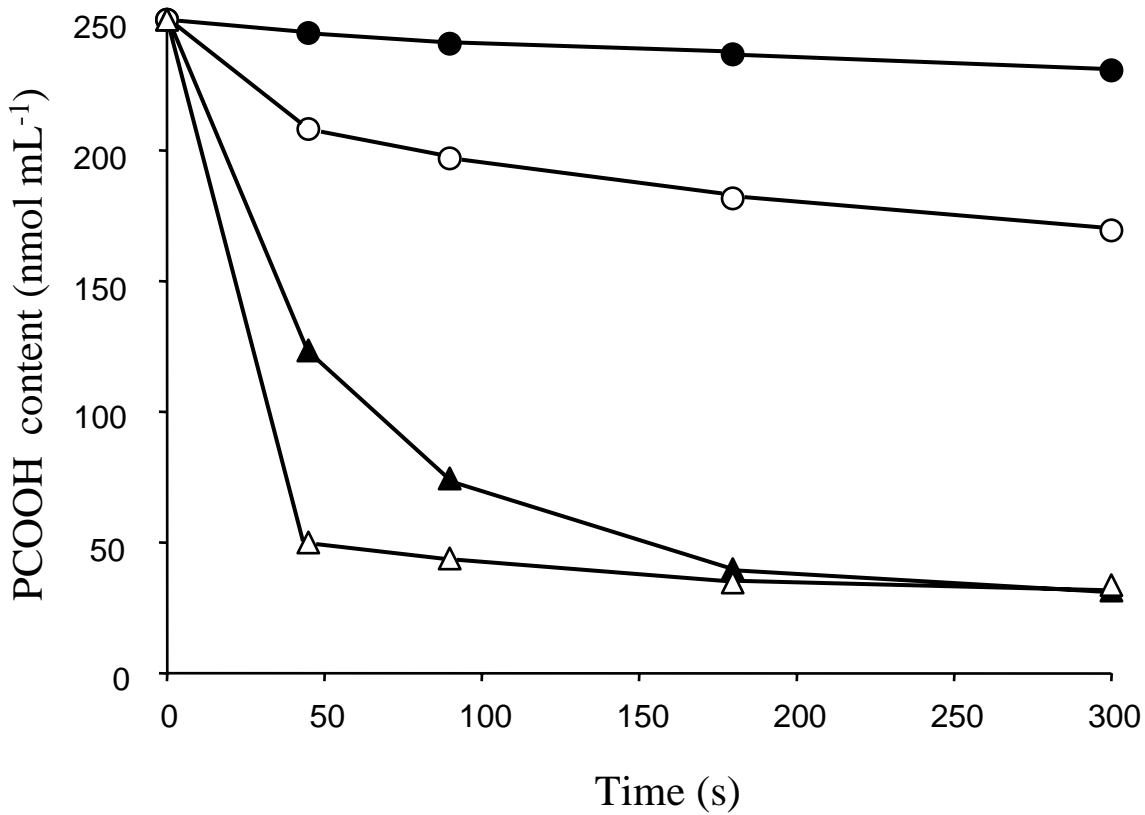

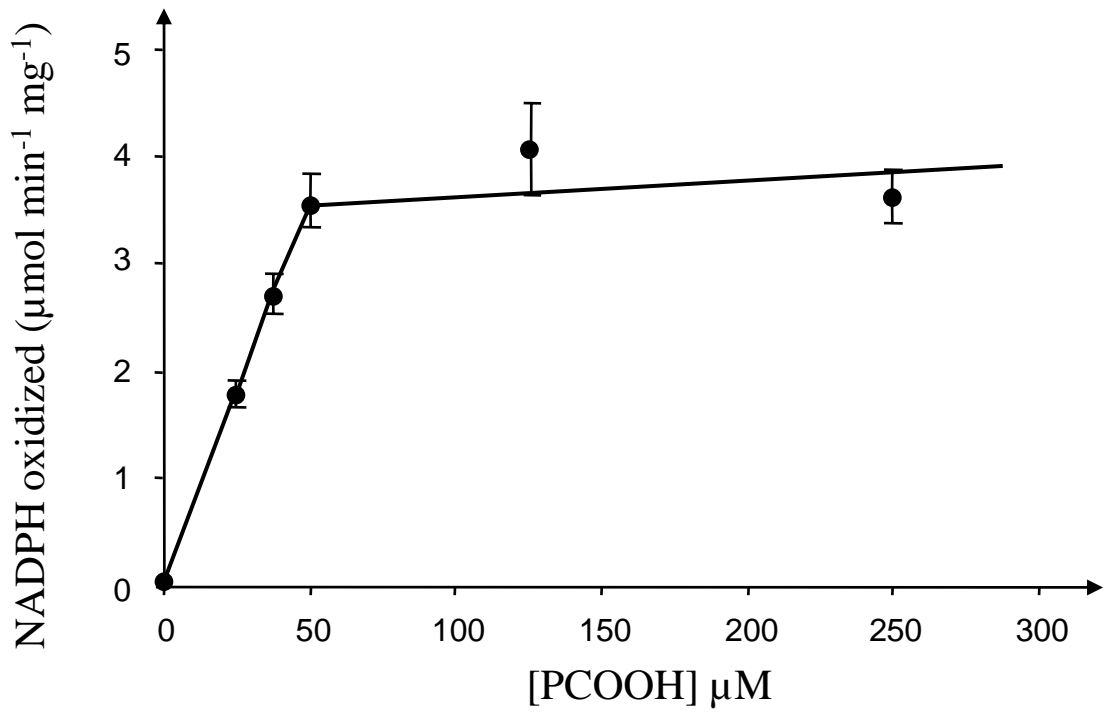

Article numéro 15 :

**Rouhier N, Gelhaye E, Gualberto J, de Fay E, Jordy MN, Hirasawa M, Duplessis S, Martin F, Knaff D, Schürmann P, Frey P, Jacquot JP.**

*Molecular characterization of chloroplastic poplar peroxiredoxin Q and its involvement in the pathogenic response.*

**En préparation**

Les Prx Q représentent un des 4 groupes de Prx chez les plantes. Ces enzymes possèdent une extension N-terminale par rapport à la protéine mature isolée chez *Sedum lineare*. Afin de déterminer la fonction de cette extension, une fusion de celle-ci avec la GFP (green fluorescent protein) a été réalisée. Elle indique que c'est un peptide d'adressage de la protéine vers les chloroplastes. Des études d'immunolocalisation démontrent que la protéine est présente dans les chloroplastes des cellules du mésophylle et des stomates. Par ailleurs, la protéine ne semble être exprimée que dans les feuilles. De plus, la quantité de Prx Q est régulée lors de l'interaction du peuplier avec un champignon pathogène *Melampsora larici-populina*. Ainsi, lors d'une réaction compatible, c'est-à-dire lorsque le champignon infecte la feuille, la quantité de Prx Q décroît durant les 24 premières heures d'infection. Lors d'une réaction incompatible, c'est-à-dire lorsque la plante lutte pour repousser le champignon et qu'elle met en place une réponse hypersensible caractérisée par la formation de ROS, la quantité de cette protéine augmente fortement dès la première heure d'infection. Cette Prx semble donc jouer un rôle dans la réponse à une infection par un pathogène. D'un point de vue biochimique, ce sont des enzymes monomériques et leur mécanisme catalytique passe par la formation d'un pont disulfure intramoléculaire entre les deux cystéines contenues dans la séquence, les cystéines 46 et 51. Ce pont disulfure n'est réduit que par les Trx mais pas par les Grx. Pourtant, le mutant Prx Q C51S est toujours actif avec les Trx comme donneur d'électrons mais le devient aussi avec les Grx comme si l'absence de cette cystéine permettait aux Grx de réduire directement le SOH formé lors de la catalyse. Le fait que la Grx ne puisse pas réduire le pont disulfure pourrait s'expliquer par le potentiel rédox très négatif de la Prx, de l'ordre de -325 mV à pH 7. Enfin, il ne semble pas qu'il existe de spécificité de reconnaissance *in vitro* entre les Prx Q et les différentes isoformes de Trx puisque des Trx cytosoliques réduisent mieux la Prx Q que les Trx chloroplastiques.



Biological sciences : Biochemistry or Plant biology

## **Molecular characterization of chloroplastic peroxiredoxin Q from poplar and its involvement in the pathogenic response**

Rouhier Nicolas<sup>\*\*\*</sup>, Gelhaye Eric<sup>\*</sup>, Gualberto José M<sup>†</sup>, Jordy Marie-Noelle<sup>\*</sup>, De Fay Elisabeth<sup>\*</sup>, Hirasawa Masa<sup>‡</sup>, Duplessis Sébastien<sup>\*</sup>, Lemaire Stéphane<sup>§</sup>, Frey Pascal<sup>¶</sup>, Martin Francis<sup>\*</sup>, Manieri Wanda<sup>||</sup>, Knaff David<sup>‡</sup>, Jacquot Jean-Pierre<sup>\*</sup>

<sup>\*</sup> Unité Mixte de Recherche INRA-UHP 1136, Interactions Arbres/Micro-organismes, Université Henri Poincaré, Faculté des Sciences, BP 239 54506 Vandoeuvre Cedex France.

<sup>†</sup> Institut de Biologie Moléculaire des Plantes, CNRS 67084 Strasbourg Cedex

<sup>‡</sup> Department of Chemistry and Biochemistry, and Center for Biotechnology and Genomics, Texas Tech University, Lubbock, Texas 79409-1061, USA.

<sup>§</sup> Institut de Biotechnologie des Plantes, Université de Paris Sud 91405 Orsay cedex.

<sup>¶</sup> INRA, Unité Pathologie Forestière, F-54280 Seichamps, France

<sup>||</sup> Laboratoire de Biochimie Végétale CH-2007 Neuchatel, Switzerland

<sup>\*\*</sup> To whom correspondence should be addressed:

Unité Mixte de Recherche INRA-UHP 1136, Interactions Arbres/Micro-organismes, Université Henri Poincaré, Faculté des Sciences, BP 239 54506 Vandoeuvre Cedex France. Telephone. ++33383684225 email: nrouhier@sbiol.uhp-nancy.fr

Abbreviations : BCP, bacterioferritin comigratory protein ; CUOOH, cumene hydroperoxide ; Grx, glutaredoxin ; NTR, NADPH thioredoxin reductase ; Prx peroxiredoxin ; tBOOH, tertio-butyl hydroperoxide ; Trx, thioredoxin.

## Abstract

Peroxiredoxins are ubiquitous thioredoxin or glutaredoxin dependent peroxidases, the function of which is to destroy peroxides. Peroxiredoxin Q, one of the four plant subtypes, is a homolog of the bacterial bacterioferritin comigratory proteins. We show here that the poplar protein acts as a monomer with an intramolecular disulfide bridge between two conserved cysteines. A broad spectrum of electron donors and substrates was tested. Unlike type II peroxiredoxin, peroxiredoxin Q cannot use glutaredoxin but various cytosolic chloroplastic and mitochondrial thioredoxins are efficient electron donors with no marked specificities. The redox potential of the peroxiredoxin Q catalytic disulfide is -325 mV at pH 7.0, explaining why the WT protein is reduced by thioredoxin (-290 mV) but not by glutaredoxin (*ca* -230 mV). Peroxiredoxin Q can reduce various alkyl hydroperoxides, but with a better efficiency for cumene hydroperoxide than hydrogen peroxide and tertiary butyl hydroperoxide. Additional evidence that Trx can be a donor was obtained by the formation of heterodimers between peroxiredoxin Q and monocysteinic mutants of spinach thioredoxin m. The use of a green fluorescence protein construct indicates that the transit sequence efficiently targets peroxiredoxin Q to the chloroplasts and especially to those of the guard cells. Immunolocalization confirms that peroxiredoxin Q is located in chloroplast. The expression of this protein is modified in response to an infection by various races of *Melampsora larici-populina*, the causative agent of the poplar rust. In the case of an hypersensitive response, the peroxiredoxin expression increased whereas it decreased, during a compatible interaction.

## Introduction

Organisms living under aerobic conditions have developed an array of antioxidative systems to protect the cells from oxidative damages caused by reactive oxygen and nitrogen species (ROS, RNS). An emerging family of non-heme peroxidases, called peroxiredoxins (Prx) has been described in all kingdoms during the past years (1, 2, 3). These ubiquitous proteins are able to reduce both organic and inorganic hydroperoxides with electrons provided mainly by NADPH or NADH and different proteins such as thioredoxin (Trx), glutaredoxin (Grx), cyclophilin A and subunit F of alkyl hydroperoxide reductase subunit F (AhpF) (1, 4, 5, 6). In addition to their documented activity as peroxidases, peroxiredoxins are involved in resistance to RNS (7, 8). The C subunits of many bacterial alkyl hydroperoxide reductase (AhpC) also possesses a peroxynitrite reductase activity (9). Recently, a complex reduction system of AhpC was found to occur in *Mycobacterium tuberculosis* with an electron flow starting from NADH and involving a dihydrolipoamide dehydrogenase, a dihydrolipoamide succinyl-transferase and an alkyl hydroperoxide reductase subunit D (AhpD) (10). The peroxiredoxins were first classified into two subclasses, the 1-Cys Prx and the 2-Cys Prx according to the number of conserved cysteines. However, the increasing number of Prx found in all organisms leads to a more complex hierarchy. Indeed, there are at least six Prx isoforms in mammals, five in yeast, and eight out of the ten genes present in the genome of *Arabidopsis thaliana* are expressed (3, 11, 12). The plant sequences can be organized into four distinct subgroups (3, 13). The first one corresponds to the 1-Cys Prx. These are seed restricted enzymes which are mainly localized in the nucleus of the embryo and the aleurone layer (14). The second group, which comprises the dimeric 2-Cys Prx, is well characterized in terms of function and catalysis (3, 15, 16). These proteins, homologous to the mammalian Prx I to IV and bacterial AhpC, are chloroplastic enzymes. The third class is a large group of monomeric type II Prx, with at least four expressed isoforms in *A. thaliana*. Two of these are assumed to be cytosolic enzymes, the two other are probably chloroplastic and mitochondrial (17-19). Finally, the last class is constituted by Prx Q, an enzyme homologous to the bacterioferritin comigratory proteins (BCP). Until recently, this type of enzyme was only found in prokaryotes and lower eukaryotes but an enzyme of *Sedum lineare* has been recently characterized (20). Up to now, there are no homologous of Prx Q in mammalian cells. Apparently, this enzyme is a monomer with an intramolecular disulfide bridge between two cysteine residues separated by only four amino acids (20). The functions of the BCP and Prx Q are not very well understood. BCP is involved in the resistance of *Escherichia coli* against

various oxidants and overexpressed in *Frankia sp.* during the formation of symbiosis with *Alnus glutinosa* (21, 22). In *Helicobacter pylori*, the role of this protein in resistance to oxidative and nitrosative stress is minimal in comparison to the two other Prx existing in this organism (23). In *A. thaliana*, the transcripts of Prx Q were found to decrease with leaf age, after a transfer to low light intensity, in response to a salt stress or to an exogenous application of ascorbate (19, 24). On the other hand, the transcript levels of Prx Q were found to increase in response to oxidative stresses generated by hydrogen peroxide (H<sub>2</sub>O<sub>2</sub>) or tertio-butyl hydroperoxide (tBOOH) or to a transfer to high light (24). The physiological electron donor for this enzyme is not currently known, even though Prx Q was retained on a monocysteinic Trx m mutant column (25).

This work focuses first on the biochemical properties of the poplar Prx Q in terms of catalytic mechanism, electron donor and substrate specificities. In addition, the cellular and subcellular localizations and the function of this enzyme were investigated. We found that Prx Q is definitely a chloroplastic enzyme as suggested by its N-terminal extension and that it participates in the response to the infection of poplar by the rust fungus *Melampsora larici-populina*.

## Materials and Methods

### Materials

Poplar Trx h1, h2, h3 and Grx were purified as described previously (26-29). *Arabidopsis thaliana* NTR and WT and mutant spinach thioredoxin m and f were prepared as in (30, 31). The sequence of *Chlamydomonas reinhardtii* Trx y (CrTrx y) is described in (32). The production and purification of poplar cyclophilin will be described later.

### Cloning of poplar Prx Q and site-directed mutagenesis

The ORF of poplar Prx Q in which the nucleotide sequence encoding the chloroplastic transit peptide was deleted, was cloned by PCR from a leaf cDNA library from *Populus tremula* x *P. tremuloides* into the expression plasmid pET-3d between the two restriction sites *Nco*I and *Bam*HI with the following oligonucleotides:

forward oligonucleotide 5' CCCCCCCATGGCTAAGGTAAACAAAGG 3'

reverse oligonucleotide 5' CCCCCGATCCTCAAAGGCTTTGAAGTAGTTT 3'.

Both restriction sites are underlined. The recombinant plasmid was called pET-3d Prx Q WT. This construction was made possible by deleting the transit sequence until the phenylalanine residue in position 63 by comparison with the mature Prx Q of *Sedum lineare*. The recombinant protein starts thus with the sequence MAKVN. The mutation into serine of the two cysteine residues in position 46 and 51 was made by PCR-mediated site-directed mutagenesis with two complementary mutagenic primers. The mutagenic primers are as follows:

C46S forward 5' GATGAAACCCCTGGGAGCACCAAACAGGCCTG 3'

C46S reverse 5' CAGGCCTGTTTGGTGCTCCCAGGGGTTTCATC 3'

C51S forward 5' GGGTGCACCAAACAGGCCAGTGCTTTTAGAGATTC 3'

C51S reverse 5'GAATCTCTAAAAGCACTGGCCTGTTTGGTGCACCC 3'

Mutagenic bases are in bold characters. The two plasmids constructed were called pET-3d Prx Q C46S and pET-3d Prx Q C51S. The nature of each mutation was verified by DNA sequencing.

### Expression and purification of WT and mutant poplar Prx Q

*Escherichia coli* strain BL21(DE3) was cotransformed with the helper plasmid pSBET and each of the recombinant plasmids (33). Cultures of 5 liters of ampicillin and kanamycin resistant clones were induced with 100  $\mu$ M IPTG during 4 hours. The cells were then

harvested by centrifugation at 4400 x g and suspended in buffer A (30 mM Na-acetate pH 5.5, 1 mM EDTA, 200 mM NaCl) in the presence of 5 mM DTT. Bacteria were lysed by sonication for 5 minutes. The extract was then precipitated between 25 and 80% of ammonium sulfate saturation. This fraction was successively subjected to an ACA 44 gel filtration equilibrated with buffer A and after dialysis to a carboxymethyl cellulose equilibrated with buffer A without NaCl. Proteins were eluted with a gradient of NaCl between 0 and 0.4 M and then dialyzed and concentrated against buffer A without NaCl. The homogeneity of the proteins was assessed by 15 % SDS-PAGE.

### **Trx linked peroxidase activity**

The reaction mixture (50  $\mu$ L) contained 30 mM Tris HCl pH 7.0, 500  $\mu$ M DTT, 1  $\mu$ M Prx Q and various concentrations of Trx or Grx ranging between 1 and 50  $\mu$ M. The reaction was started by adding 500  $\mu$ M H<sub>2</sub>O<sub>2</sub>. After 3 minutes, 5  $\mu$ L were mixed with 495  $\mu$ L of the FOX1 (ferrous oxidation in xylenol orange) reagent (34). The absorbance was then read at 560 nm after one hour incubation.

The peroxidase activity of Prx Q was also measured by following the NADPH oxidation at 340 nm with the Trx systems (*Arabidopsis thaliana* NTR/poplar Trx h3) as reductants and with H<sub>2</sub>O<sub>2</sub>, tBOOH and cumene hydroperoxide (CUOOH) following a procedure already described for poplar type II Prx (3). The only slight modification is that the reaction was made in 50 mM K<sup>+</sup>/Na<sup>+</sup> phosphate buffer pH 7.0. The determination of the catalytic parameters was effected with 1  $\mu$ M Prx Q by varying the concentration of one substrate at saturating concentrations of the other substrate (6  $\mu$ M Trx h3 or 200  $\mu$ M hydroperoxide).

### **Formation of heterodimers between Prx Q C51S and Trx m C40S or Trx f C49S**

The formation of heterodimers between poplar Prx Q WT or C51S and spinach Trx m C40S or Trx f C49S was realized by derivatizing the various Prx Q with DTNB to form Prx Q-TNB as described for thioredoxin reductase in (35) or by diamide treatment in the presence of poplar donors (Trx h1 C42S, Grx C30S, cyclophilin A) as in (4). For the DTNB treatment, Prx Q was reduced with 20 mM DTT, dialyzed and then reacted with a 50 fold excess of DTNB. The mixture was then dialyzed to eliminate this excess. Equimolar concentrations of Prx Q-TNB and reduced Trx or Grx monocysteine mutants or WT cyclophilin A were used to create heterodimers in 30 mM Tris HCl pH 7.0, 1 mM EDTA. The mixture was then subjected to SDS-PAGE under non-reducing conditions.

### **Thiol titration**

500  $\mu\text{g}$  of Prx Q wt, C46S and C51S were reduced by 10 mM DTT during 30 minutes at room temperature, then precipitated with one volume of 20% trichloroacetic acid (TCA) and stored on ice for 30 minutes. The mixture was centrifuged for 10 minutes at 13000  $\times g$  and washed two times with 2% TCA. The precipitate was resuspended in Tris-HCl 30 mM pH 7.0, EDTA 1 mM, 1% SDS. The concentration was estimated by UV spectrophotometry ( $\epsilon_{\text{M}} = 13490 \text{ M}^{-1} \text{ cm}^{-1}$ ) before adding DTNB to a final concentration of 100  $\mu\text{M}$ . After one hour incubation in the dark, the absorbance was read at 412 nm and the thiol content estimated using a molar extinction coefficient of  $13600 \text{ M}^{-1} \cdot \text{cm}^{-1}$ .

### **Determination of the redox potential**

Redox titrations were performed using monobromobimane (mBBr) as in (36). Prx Q at a concentration of 100-200  $\mu\text{g}/\text{mL}$  (6 to 12  $\mu\text{M}$ ) was incubated in 500  $\mu\text{L}$  aliquots at defined  $E_{\text{h}}$  values obtained by varying oxidized and reduced dithiothreitol (total concentration 2.5 mM) for 3 hours. An  $E_{\text{m}}$  value of  $-330 \text{ mV}$  and a value of 9.2 was used for the  $\text{pK}_{\text{a}}$  of the more acidic thiol of reduced DTT (references listed in 36). The following buffers were used : MES pH 6.0, MOPS pH 6.5 to 7.5, Tricine pH 8.0 to 8.5, Bistris-propane pH above 8.5. After equilibrating the Prx Q sample at the defined  $E_{\text{h}}$  values with the DTT redox buffers, mBBr dissolved in acetonitrile was added to a final concentration of 10 mM. After 20 min incubation with mBBr, the Prx Q was precipitated by addition of 500  $\mu\text{L}$  20% TCA. The resulting protein pellet obtained by centrifugation was washed and dissolved in 100 mM Tris-HCl buffer pH 8.0 and 1% SDS. The fluorescence of these samples was measured at 450 nm,

excited by 380 nm light, using an Aminco-Bowman Series 2 Luminescence Spectrofluorimeter. Fitting of the data was done as in (36).

### **Infection of the leaves, protein extraction, antibody purification and Western blot analysis**

*Populus x interamericana* 'Beaupré' plants were grown for 12 weeks in a greenhouse from dormant cuttings in pots containing a sand-peat mixture. Fully expanded leaves were detached and spray-inoculated on their abaxial surface with an urediniospore suspension in water-agar (0.1 g.l<sup>-1</sup>) adjusted to 5000 urediniospores.ml<sup>-1</sup> or with water-agar (control). Two isolates of *M. larici-populina* were used: 98AG31 (pathotype 3-4-7) and 93ID6 (pathotype 3-4), virulent and avirulent, respectively, on 'Beaupré' (37). The inoculated leaves were then incubated with the abaxial surface uppermost, floating on deionized water in Petri dishes, at 20°C under artificial illumination, for various durations ranging from 1 hour to 10 days. 400 mg of leaves were ground with a mortar and pestle on ice and then 4 mL of the extraction buffer (50 mM Tris HCl pH 7.5, 1 mM EDTA, PVP 2.5 mg/mL and 25 mM β-mercaptoethanol) were added. The mixture was centrifuged twice for 10 minutes at 14000 x g and the supernatant precipitated with 80% acetone. Proteins were pelleted by centrifugation and washed with 80% acetone. Proteins were resuspended in 125 mM Tris-HCl buffer (pH 6.8) containing glycerol 20%, SDS 2%, β-mercaptoethanol 5% and bromophenol blue 0.05% and their concentration was determined by the Bradford reaction kit from BIO-RAD. Protein extraction of untreated leaves, stems and roots was carried out as described in (18). Polyclonal antibodies raised in rabbit against poplar Prx Q were purified by affinity on a Prx Q Sepharose column following the procedure described previously (18). Western blots were performed using PVDF membranes from Millipore and the Immune Star Goat Anti Rabbit Detection Kit from BIO-RAD.

### **Intracellular localization via GFP fusion**

For *in vivo* intracellular localization, the first 195 bp of the poplar Prx Q cDNA, corresponding to the N-terminal presequence (65 amino acids) were cloned into the *NcoI* and *BamHI* sites of pCK-GFP3A using the two following primers:

5' CCCCCATGGCTTCCATTTCTCTC 3' and

5' CCCCGGATCCTTGGCAAAAATGGTATTCTT 3'



The PCR amplified fragment was fused to GFP at the *Bam*HI site, resulting in a chimeric protein where the transit sequence of Prx Q is present on the N-terminus side of GFP and under the control of a double 35S promoter (38). *Nicotiana bentamiana* cells were transfected by bombardment of leaves with tungsten particles coated with plasmid DNA and images were obtained with a Zeiss LSM510 confocal microscope.

### **Immunolocalization**

Sections of 25 mm<sup>2</sup> were cut from expanded leaves of 2 months old poplar and fixed for 3h at 4°C in 4% paraformaldehyde (w/v) and 0.5% (v/v) glutaraldehyde in 0.1 M cacodylate buffer, pH 7.4. The samples were subsequently rinsed in 0.1 M cacodylate, treated with 2% OsO<sub>4</sub>, dehydrated in increasing alcohol and propylene oxide, embedded in Durcupan (Fluka) and finally polymerized at 56°C for 48h.

For immunocytochemistry ultrathin sections (70 nm) were placed onto 300 mesh nickel grids. Grids were floated for 15 min in a 50 mM glycine, 50 mM Tris phosphate–buffered saline (TPBS) solution, transferred for 30 min on a blocking solution of 1% BSA in Tris phosphate–buffered saline (TPBS/BSA) and then treated overnight at 4°C with purified rabbit Prx Q antibodies (diluted 100x in TPBS/BSA). Controls were realized by omission of this step. After washing, sections were incubated for 2h in a solution of 50 mM Tris-HCl buffer containing 0.05% PEG with gold-labelled goat anti-rabbit IgG (10 nm, Sigma) (dilution 1:20). After rinsing, the sections were dried and stained with uranyl acetate and lead citrate. Observations were made using a Zeiss, TEM 902 electronic microscope.

For histochemical detection of Prx Q using fluorescence, 130 nm thin sections are coated with polylysine (Sigma) on a glass slide. The resin was removed by dissolution for 20 min with ethanol saturated in NaOH washed with 100% ethanol and then with 100% acetone. Slides were treated 15 min with in TPBS solution containing 50 mM glycine, washed with TPBS and finally treated with TPBS/BSA for 2h30 before incubation with purified rabbit Prx Q antibodies overnight (diluted 100 fold). After rinsing with TPBS and TPBS/BSA, the slides were incubated for 2h with secondary antibodies coupled to FITC (fluorescein isothiocyanate) diluted 160 fold. Control experiments were performed either by omitting primary antibodies or by testing preimmune serum. The slides were rinsed and mounted in TPBS containing 50% glycerol. Sections were viewed on epifluorescence microscope (Nikon Optiphot II coupled to a mercury lamp and B2A filters) and images were captured using a Nikon D1 camera.

## Results

### Sequence analysis

The deduced amino acid sequence of the poplar enzyme studied here consists of 213 residues with a putative transit peptide of 64 residues, identified by analogy to the mature Prx Q of *Sedum lineare* (20). The recombinant mature form of poplar Prx Q used in this study contains 151 amino acids, including two residues (one methionine and one alanine) that have been added to the N-terminus immediately after the putative cleavage site of the precursor. Its calculated molecular mass and isoelectric point are 16831 Da and 9.3, respectively.

An amino acid sequence comparison of three plant Prx Q and four BCP from cyanobacteria, bacteria, yeast and archaebacteria is shown in Fig. 1. All the plant sequences contain a N-terminal extension of 60 to 70 amino acids, which was identified as a chloroplastic target sequence by prediction softwares (<http://www.cbs.dtu.dk/services/TargetP/> and <http://psort.nibb.ac.jp/form.html>). The *Saccharomyces cerevisiae* enzyme also possesses a N-terminal extension, but the cellular location of the yeast enzyme has not yet been identified. The sequences of the mature proteins, devoid of the transit peptides, are 149 to 156 amino acid long and all of them contain the two putative active site cysteines in position 46 and 51 (poplar numbering of the shortened construction). Cys 46 is the residue that is homologous to the catalytic cysteine present in all plant peroxiredoxins, whatever their subtype (consensus sequence P-(X)<sub>3</sub>-T-[P/F]-(X)-C-[T/S/P]) and which is involved in catalysis via the transient formation of a sulfenic acid. The identity levels of the sequences of the mature plant proteins range from 84 to 88%. Comparisons between plant and non-plant enzymes show much lower identity levels, ranging from 35 to 55%.

## Biochemical characterization

### *Expression, purification and mutagenesis*

Using a combination of gel filtration and cation exchange, recombinant Prx Q WT, C46S and C51S were purified to homogeneity (Fig. 2A). The overall yield was about 7 to 30 mg homogenous protein per liter of *E. coli* culture. The oxidized form of purified WT Prx Q is a monomeric enzyme as judged by its behavior during gel filtration (data not shown) and its migration in non-reducing 15% SDS PAGE (Fig. 2B, lane 4). The two monocysteine mutants are able to form measurable amounts of homodimer, presumably via disulfide bonds involving the remaining cysteine (Fig. 2B, lane 5 and 6). Thiol titrations of the reduced enzymes confirmed the presence of two thiols per mole enzyme for the reduced form of WT Prx Q, while no thiols could be detected in the oxidized state (data not shown). This observation suggests that there is an intramolecular disulfide in the monomer. Only one cysteine was detected per mol enzyme for the two mutants (data not shown).

### *Electron donor and substrate specificity*

Regardless of the conditions used, we could not observe DTT functioning as a direct electron donor to Prx Q using the FOX detection method. Activity was only observed if Trx was added to promote catalysis (Fig. 3). Thus, in order to investigate whether the enzyme exhibits a preference for a given electron donor, the efficiency of several chloroplastic donors including spinach Trx m and f and the recently described *Chlamydomonas reinhardtii* Trx y, has been studied (32). In addition, one mitochondrial Trx (poplar Trx h2, unpublished data), two cytosolic Trx (poplar Trx h1 and h3), cyclophilin A and Grx have been also tested as electron donors. Fig. 3 shows that unlike type II Prx, WT Prx Q cannot use Grx as an electron donor. Likewise, the poplar cyclophilin A used in this study was ineffective as a donor. On the other hand, all Trx tested were active with an apparent efficiency order  $h1 > y > h3 > [m, f, h2]$ . Experiments carried out with different Trx concentrations, indicated that the reactions typically saturate at Trx concentrations between 5 and 10  $\mu$ M. Experiments using NADPH reduction of poplar Trx h3, catalyzed by *Arabidopsis thaliana* NTR provides a method for monitoring spectrophotometrically the Trx dependent reduction of hydroperoxide by Prx Q. The kinetic parameters, determined in this fashion, are shown in Table I. Several hydroperoxides can be used as substrates by Prx Q in the presence of Trx h3. The reactions saturate at a Trx concentration of *ca* 6  $\mu$ M and the  $K_m$  for Trx h3, the best electron donor is around 1.5  $\mu$ M. The preferred substrate is CUOOH followed by H<sub>2</sub>O<sub>2</sub> and tBOOH when considering the catalytic efficiencies (k<sub>cat</sub>/K<sub>m</sub>).

### *Characterization of the active site by site-directed mutagenesis*

Fig. 4 shows the peroxidase activity of WT Prx Q, Prx Q C46S or C51S with H<sub>2</sub>O<sub>2</sub> as a substrate and in the presence of DTT and either WT Grx, or Grx C30S or Trx h1. As observed before, the WT Prx Q is only reduced by Trx h1 (column 7) but not by Grx (col. 1 and 4) even at high concentration (50 μM). The C46S mutant does not possess any biochemical activity, whatever the reductants (Trx, Grx) or the substrates (H<sub>2</sub>O<sub>2</sub>, tBOOH, CUOOH) used (col. 2, 5, 8 and data not shown). On the other hand, the activity of C51S mutant is not detectable at low Trx concentration (*ca* 5 μM) but it can be partially rescued by increasing the Trx concentration to 50 μM (Fig. 4, col. 9). Unexpectedly, this mutant possesses a peroxidase activity in the presence of WT Grx but it is weakly active with the mutant Grx C30S (col. 3 and 6). These results were confirmed spectrophotometrically by following the NADPH oxidation in the presence of the Trx or Grx systems (data not shown). These results fully confirm that Cys 46 is the catalytic cysteine. In the WT enzyme it is regenerated via the formation of a disulfide bridge with the adjacent Cys 51, which disulfide bond is reduced by Trx but not Grx (Fig. 4, col. 1, 4, 7). Nevertheless, it is likely that in the C51S mutant, the sulfenic acid formed in Cys 46 can be reduced directly by Trx or Grx in the absence of the second cysteine (Fig. 4, col. 3, 9).

### *Complex formation*

The biochemical characteristics described above have been confirmed by establishing that heterodimers can form between the donors and Prx Q C51S. While, in agreement with the biochemical results, cyclophilin A was unable to form heterodimers with Prx Q (data not shown). On the other hand, heterodimers were present when mixing Prx C51S and the various monocysteine Trx, either Trx f C49S or Trx h1 C42S (data not shown) or Trx m C40S (Fig. 2B, lane 2). The dissociation of this complex by excess DTT indeed proves that the heterodimer was linked by a covalent disulfide bridge (lane 4). The size of the heterodimer polypeptide (*ca* 30 kDa) is in good agreement with the addition of one Trx (13 kDa) to one Prx Q (17 kDa). The observation that WT Grx does not form stable heterodimers with Prx Q C51S, whereas it can support the activity of this mutant is consistent with the formation of a transient intermolecular disulfide bridge that is subsequently reduced by the second active site cysteine of Grx (data not shown). Grx C30S does not form dimers with Prx Q C51S while it makes excellent heterodimeric structures with type II Prx in agreement with its lower catalytic efficiency (4).

### *Redox potential*

Fig. 5 summarizes the results of redox titrations of the Prx Q disulfide over the pH range from pH 5.5 to 10.5. Each point represents the average of at least two determinations and the average deviations suggest that the experimental uncertainty in  $E_m$  is between 5 and 10 mV. Titrations at all pH values gave excellent fits to the Nernst Equation for a single two-electron redox couple. Titrations at three different total DTT concentrations in the redox buffers used (1 mM, 1.75 mM and 2.5 mM) and at two different redox equilibration times (2 and 3 hours) gave identical titration curves (within the experimental uncertainties), as expected for titrations in which redox equilibrium has been established. The  $E_m$  value for the disulfide of Prx Q at pH 7.0, determined using the mBBBr fluorescence method, is  $-325 \pm 10$  mV (Fig. 5A). A plot of  $E_m$  vs pH contains two linear regions (Fig. 5B). At pH values between 5.5 and 9.0, the slope is  $-59$  mV per pH unit, the value expected for a process in which a two-electron reduction is accompanied by the uptake of two protons (39). Between pH 9.0 and 10.5, the  $E_m$  vs pH slope is  $-29.5$  mV per pH unit, indicating that the two-electron reduction is accompanied by the uptake of only a single proton over this pH range (). The intersection of these two straight-line segments corresponds to the  $pK_a$  of an acid/base couple with a protonation state that is linked to the redox state of Prx Q (39). Although the simplest explanation for this data is that the more acidic active-site cysteine of reduced Prx Q has a  $pK_a$  value close to 9.0, thermodynamic measurements alone cannot identify the actual amino acid(s) involved in this redox-coupled proton uptake.

### **Expression and localization of Prx Q**

#### *Localization of Prx Q*

Several experiments aimed at investigating the cellular and subcellular localization of Prx Q have been undertaken. First, a transient expression experiment was carried out using a chimeric protein obtained by fusing the transit peptide of Prx Q to GFP. After bombardment of tobacco leaf epidermis (which contain epidermal cells and underlying parenchymal photosynthetic cells) fluorescence was detected in the chloroplasts of the mesophyll cells (data not shown) and also in the chloroplasts of the guard cells of stomata (Fig. 6, panel C). Control experiments showing the natural fluorescence of chlorophyll indicate that the GFP fluorescence coincides with the chloroplasts (Fig. 6, panel B). These results indicate that the transit sequence at the N-terminus of mature Prx Q efficiently targets the protein to chloroplasts and especially to those of the guard cells of stomata.

In a second series of experiments, semi-thin sections of poplar leaves have been incubated with purified Prx Q antibodies and the presence of the polypeptide detected by using anti rabbit antibodies coupled to FITC. As above with the GFP experiments, the secondary fluorescence was found in the chloroplasts of mesophyll cells and also in the chloroplasts of guard cells (data not shown). Immunocytochemistry experiments indicate that Prx Q is present both in the stromal part of the chloroplasts and also somehow associated with the thylakoid membranes in a distribution similar to the one observed for 2-Cys peroxiredoxin (Fig. 7) (16).

#### *Expression of Prx Q and involvement in the pathogenic response*

The expression of Prx Q was followed both at the mRNA and protein levels in roots, stems or leaves and leaves inoculated or not by the rust fungus *Melampsora larici-populina* either in the case of a compatible or a incompatible reaction.

The expression of *prx Q* in plant organs was investigated by recording the number of ESTs encoding this protein in the Genbank database. Only nine ESTs are present out of a total of 114443, which suggests that the gene is transcribed at very low levels in leaves (4 hits), bark (3 hits) and flowers (2 hits). Fig. 8A shows that the Prx Q polypeptide is only present in detectable amounts in leaves but not in stems or roots.

On the other hand, the content in Prx Q polypeptide increased markedly with the time of infection in the case of a hypersensitive response (Fig. 8B) with a maximum at *ca* 24 hours. Conversely, in the compatible reaction, the Prx Q content decreased as infection proceeded (Fig. 8C). After 10 days of infection, the Prx Q content is approximatively equivalent to the one before infection. In non infected leaves (control), the relative amount of Prx Q remained nearly unchanged (Fig. 8D).

## Discussion

Peroxiredoxins from plants, like their counterparts in other biological organisms, are subjects of great current interest because of their documented or sometimes postulated protective role in oxidative or nitrosative stress. Two subtypes have been extensively studied, the chloroplastic dimeric 2-Cys Prx and the type II Prx. Less is known about the 1-Cys Prx and the Prx Q. We present here new data concerning the molecular mechanism, substrate and donor specificity and *in vivo* function and localization of Prx Q in poplar, a woody species.

### *Catalytic mechanism*

Using recombinant technology and site-directed mutagenesis, we have identified the active site of the poplar enzyme as an intramolecular disulfide which involves Cys 46 and Cys 51. Based on several lines of evidence, Cys 46 is proposed to be the catalytic cysteine. First it is in a conserved position with respect to all other Prx types where it has been shown to be the peroxidatic cysteine. Secondly, the C46S mutant is inactive while the C51S mutant is partially active at high electron donors concentration. We propose here that in the wild type form of the enzyme, the regeneration of Cys 46 involves the transient formation of a disulfide with Cys 51 which is subsequently reduced by Trx but not Grx. In the C51S mutant, the sulfenic acid can be reduced directly by Trx or Grx, albeit these results were not physiologically relevant because these isoforms of Trx and Grx used here are not located in the chloroplast (Fig. 3). These data for the WT or the Prx Q C51S mutant are depicted in the reaction scheme presented in Fig. 9. These observations are in agreement with results obtained for the BCP from *E. coli*, for which only the equivalent of Cys 46 is essential and the two other BCP cysteines are dispensable (21). A complete alignment analysis of BCP is also consistent with this observation. Whereas the first cysteine is totally conserved, the second is not present in BCP from *Helicobacter pylori* or *Synechocystis sp.* (accession numbers AAD05701 and BAA16704). Although site-directed mutagenesis experiments carried out with the *Sedum lineare* enzyme have been interpreted in terms of two essential cysteines (20), the experiments using mutated *S. lineare* enzyme did not investigate the possibility of activity at high Trx concentrations (20).

### *Substrate specificity*

From the biochemical analysis of poplar Prx Q, we found that its catalytic efficiency vs  $\text{H}_2\text{O}_2$  (kcat/Km of  $7.98 \times 10^3 \text{ M}^{-1} \text{ s}^{-1}$ ) is comparable to the value obtained for the *E. coli* BCP

( $2.45 \times 10^3 \text{ M}^{-1} \text{ s}^{-1}$ ) and to those of the 2-Cys Prx from *A. thaliana* ( $36 \times 10^3 \text{ M}^{-1} \text{ s}^{-1}$ ) (16, 21). In addition to reducing  $\text{H}_2\text{O}_2$ , Prx Q also catalyses the reduction of other artificial peroxides, with a preference for CUOOH compared to tBOOH. The fact that Prx Q does not display the same affinity *vs* the various peroxides tested (see Table II), indicates that the active site has a remarkable flexibility (*i.e.* it accomodates substrates with very diverse structures) but also possesses some selectivity as all substrates are not equally reduced. Given the important roles postulated for  $\text{H}_2\text{O}_2$ , especially in the chloroplast metabolism, these findings are likely to be of physiological importance.

### *Physiological electron donor*

The chloroplast of photosynthetic organisms is a complex organelle which contains a multiplicity of proteins with possible similar function. Indeed, in addition to many ascorbate or glutathione peroxidases, four Prx isoforms are also found in the chloroplasts of *A. thaliana*; two dimeric 2-Cys Prx, one type II Prx and one Prx Q (3). On the other hand, a large number of Trx isoforms are likely to be located in this compartment, four Trx m, two Trx f, two Trx y, one Trx x and CDP32 (chloroplast drought-induced protein of 32 kDa), a thioredoxin-like protein which is able to reduce the 2-Cys Prx (40, 41). Earlier studies with the *Sedum* enzyme used the couple *E. coli* Trx/ *E. coli* Trx reductase as an electron donor for the reaction which is not a physiological reductant (20). We have carried out an extensive study of the electron donor specificity of Prx Q, testing a large number of chloroplastic and non-chloroplastic thioredoxins. Although all Trx tested were able to serve as electron donors, their efficiencies differed. The most efficient reductant is a cytosolic Trx suggesting there is no marked specificity between the thioredoxins for the reduction of this enzyme (Fig. 3). On the other hand, other documented donors such as glutaredoxin and cyclophilin A are totally inefficient with the WT Prx Q (4, 5). This observation clearly separates Prx Q from type II Prx which can use both Trx and Grx as electron donors (4).

As has been observed for dimeric 2-Cys Prx, DTT cannot serve as a direct donor for Prx Q, in contrast to its ability to serve as a donor to type II Prx (24). As the redox potential of DTT is sufficient to reduce Prx Q (see below), this observation suggests an important role for the active site of Trx in the protein/protein recognition needed for the interaction with the catalytic disulfide of Prx Q. While it will be necessary to obtain the 3D structure of Prx Q to understand the detailed nature of these molecular contacts, some insight is provided by the recently resolved structure of a fusion protein from *Haemophilus influenzae* between Prx and Grx modules (42). The interactions between Prx and Grx derived from charged interactions



between three Asp residues of Prx in position 148, 154 and 156 and Lys and Arg of Grx whereas the interactions between Prx and Trx are of hydrophobic nature. In poplar, the type II Prx which was previously found to interact with Grx possess two Glu residues equivalent to the Asp residues in position 148 and 156 partly explaining the interaction (4, 42). When comparing all these proteins with poplar Prx Q, we can observe that Prx Q possesses two Glu residues (at positions 200 and 205) in position equivalent to Asp148 and 154 of the Prx/Grx fusion that might be involved in similar electrostatic interactions. These observations could explain why Prx Q C51S is able to interact with Grx but not why the disulfide bond of WT Prx Q is not reduced catalytically by Grx.

In order to assess whether a thermodynamic barrier exists for the reduction of Prx Q by Grx, we carried out an extensive series of oxidation-reduction titrations of Prx Q. The  $E_m$  value of -325 mV, measured for Prx Q at pH 7.0, explains why Grx, with an  $E_m$  value at pH 7.0 between -200 to -230 mV (43) is such a poor donor in this reaction. The  $E_m$  value for poplar Prx Q is more negative than those of other peroxiredoxins, which range from -320 mV (2-Cys Prx B) to -288 mV (Prx II B) (16) and reduction of the poplar enzyme by Trx would be slightly unfavorable. This situation is similar to those observed for reduction of the regulatory disulfide of chloroplast FBPase ( $E_m$  values of -305 and -315 mV have been reported for the spinach and pea enzymes, respectively, while the  $E_m$  for pea and spinach Trx f is -290 mV) and the reduction of the C-terminal regulatory disulfide of sorghum NADP-malate dehydrogenase ( $E_m$  of -330 mV) by Trx m ( $E_m$  of -300 mV) (44). Despite the slightly unfavorable  $\Delta E_m$  values of 20 to 30 mV, reduction of these regulatory disulfides can occur efficiently but the much greater  $\Delta E_m$  of *ca* 100 mV for reduction of Prx Q by Grx is probably too high for the reaction to proceed.

#### *Expression and localization of Prx Q*

Among the three organs tested, leaves, stems and roots, Prx Q is only expressed in leaves. The cellular and subcellular distribution of Prx Q in leaves has been investigated by immunofluorescence or immunogold labelling. All techniques gave similar results, indicating that the protein is localized in the chloroplasts of mesophyll cells and also in those of the guard cells of stomata. This observation is in good agreement with the predictions made on the basis of the transit sequence analysis. As  $H_2O_2$  is known to be a compound which affects stomatal closure, the intervention of Prx Q in this process is rather likely (45). In addition, pathogen attacks of leaves very often involve the colonization of the fungus via the ostiole of the stomata (46). This second property together with the important observation that Prx Q is

highly overproduced in poplar leaves inoculated with an incompatible isolate of *Melampsora*, strongly suggests that Prx Q may play an important role to control the content of reactive species in mesophyll cells and also especially at the stomatal level. The transcription of a type II Prx in pepper leaf was shown to respond to bacterial infection by *Xanthomonas campestris* pv. *vesicatoria* (47). Moreover, as in the case of animal cells, when plants are submitted to a pathogenic attack, they respond to an host invasion by producing in the infected tissues H<sub>2</sub>O<sub>2</sub> and nitric oxide (NO) during the hypersensitive response for direct intoxication of the pathogen and induction of defence-related gene expression in adjacent cells (48-51). Moreover, the peroxide dependent synthesis, deposition and assembly of lignin, cellulose, suberin and other cell wall thickening materials during fungal infection results in papilla hardening driven by cross-linking reactions (51). Subsequently, plant cells may need to be protected against the damaging ROS and RNS and Prx Q could be a first line of defense for the photosynthetic cells.

## References

1. Chae, H.Z., Chung, S.J. & Rhee, S.G. (1994) *J. Biol. Chem.* **269**, 27670-27678.
2. Chae, H.Z., Robison, K., Poole, L.B., Church, G., Storz, G. & Rhee, S.G. (1994) *Proc. Natl. Acad. Sci. USA* **91**, 7017-7021.
3. Dietz, K.J., Horling, F., König, J., & Baier, M. (2002) *J. Exp. Bot.* **53**, 1321-1329.
4. Rouhier, N., Gelhaye, E., & Jacquot, J.P. (2002) *J. Biol. Chem.* **277**, 13609-13614.
5. Lee, S.P., Hwang, Y.S., Kim, Y.J., Kwon, K.S., Kim, H.J., Kim, K., & Chae, H.Z. (2001) *J. Biol. Chem.* **276**, 29826-29832.
6. Niimura, Y., Poole, L.B., & Massey, V. (1995) *J. Biol. Chem.* **270**, 25645-25650.
7. Sakamoto, A., Tsukamoto, S., Yamamoto, H., Ueda-Hashimoto, M., Takahashi, M., Suzuki, H., & Morikawa, H. (2003) *Plant J.* **33**, 841-851.
8. Wong, C.M., Zhou, Y., Kung, H.F., & Jin, D.Y. (2002) *J. Biol. Chem.* **277**, 5385-5394.
9. Bryk, R., Griffin, P., & Nathan, C. (2000) *Nature* **407**, 211-215.
10. Bryk, R., Lima, C.D., Erdjument-Bromage, H., Tempst, P., & Nathan, C. (2002) *Science* **295**, 1073-1077.
11. Fujii, J. & Ikeda, Y. (2002) *Redox Rep.* **7**, 123-130.
12. Park, S.-G., Cha, M.K., Jeong, W., & Kim, I.H. (2000) *J. Biol. Chem.* **275**, 5723-5732.
13. Rouhier, N. & Jacquot, J.P. (2002) *Photosynthesis research* **74**, 259-268.
14. Stacy, R.A., Nordeng, T.-W., Cullanez-Macia, F.A., & Aalen, R.B. (1999) *Plant J.* **19**, 1-8.
15. Goyer, A., Haslekas, C., Miginiac-Maslow, M., Klein, U., Le Marechal, P., Jacquot, J.P., & Decottignies, P. (2002) *Eur. J. Biochem.* **269**, 272-282.
16. König, J., Baier, M., Horling, F., Kahmann, U., Harris, G., Schurmann, P., & Dietz, K.J. (2002) *Proc. Natl. Acad. Sci. USA* **99**, 5738-5743.
17. Choi, Y.O., Cheong, N.E., Lee, K.O., Jung, B.G., Hong, C.H., Jeong, J.H., Chi, Y.H., Kim, K., Cho, M.J., & Lee, S.Y. (1999) *Biochem. Biophys. Res. Commun.* **258**, 768-771.
18. Rouhier, N., Gelhaye, E., Sautiere, P.-E., Brun, A., Laurent, P., Tagu, D., Gerard, J., de Fay, E., Meyer, Y., & Jacquot, J.P. (2001) *Plant Physiol.* **127**, 1299-1309.
19. Horling, F., König, J. & Dietz, K.J. (2002) *Plant Physiol. Biochem.* **40**, 491-499
20. Kong, W., Shiota, S., Shi, Y., Nakayama, H., & Nakayama, K. (2000) *Biochem. J.* **351**, 107-114.
21. Jeong, W., Cha, M.-K., & Kim, I.H. (2000) *J. Biol. Chem.* **275**, 2924-2930.

22. Hammad, Y., Marechal, J., Cournoyer, B., Normand, P., & Domenach, A.M. (2001) *Can. J. Microbiol.* **47**, 541-547.
23. Comtois, S.L., Gidley, M.D. & Kelly, D.J. (2003) *Microbiology* **149**, 121-129.
24. Horling, F., Lamkemeyer, P., Konig, J., Finkemeier, I., Kandlbinder, A., Baier, M., & Dietz, K.J. (2003) *Plant Physiol.* **131**, 317-325.
25. Motohashi, K., Kondoh, A., Stumpp, M.T., & Hisabori, T. (2001) *Proc. Natl. Acad. Sci. USA* **98**, 11224-11229.
26. Behm, M., & Jacquot, J.P. (2000) *Plant Physiol. Biochem.* **38**, 363-369.
27. Gelhaye, E., Rouhier, N., Vlamis-Gardikas, A., Girardet, J.M., Sautiere, P.E., Sauzet, M., Martin, F., & Jacquot, J.P. (2003) *Plant Physiol. Biochem.* *In press*
28. Gelhaye, E., Rouhier, N., Laurent, P., Sautiere, P.E., Martin, F., & Jacquot, J.P. (2002) *Physiol. Plant.* **114**, 165-171.
29. Rouhier, N., Gelhaye, E., Sautiere, P.E. & Jacquot, J.P. (2002) *Protein Expr. Purif.* **24**, 234-241.
30. Jacquot, J.P., Rivera-Madrid, R., Marinho, P., Kollarova, M., Le Marechal, P., Miginiac-Maslow, M., & Meyer, Y. (1994) *J. Mol. Biol.* **235**, 1357-1363.
31. Capitani, G., Markovic-Housley, Z., DelVal, G., Morris, M., Jansonius, J.N., & Schürmann, P. (2000) *J. Mol. Biol.* **302**, 135-154.
32. Lemaire, S.D., Collin, V., Keryer, E., Issakidis-Bourguet, E., Lavergne, D. & Miginiac-Maslow, M. (2003) *Plant Physiol. Biochem.*, *In press*.
33. Schenk, P.M., Baumann, S., Mattes, R., & Steinbiss, H.H. (1995) *Biotechniques* **19**, 196-200.
34. Wolff, S.P. (1994) *Methods Enzymol.* **233**, 182-189.
35. Wang, P.F., Veine, D.M., Ahn, S.H., & Williams, C.H. (1996) *Biochemistry* **35**, 4812-4819.
36. Krimm, I., Lemaire, S., Ruelland, E., Miginiac-Maslow, M., Jacquot, J.P., Hirasawa, M., Knaff, D.B., & Lancelin, J.M. (1998) *Eur. J. Biochem.* **255**, 185-195.
37. Miot, S., Frey, P., & Pinon, J. (1999) *Eur. J. Forest Pathol.* **29**, 411-423.
38. Menand, B., Marechal-Drouard, L., Sakamoto, W., Dietrich, A., & Wintz, H. (1998) *Proc. Natl. Acad. Sci. USA* **95**, 11014-11019.
39. Chivers, P.T., Prehoda, K.E., & Raines, R.T. (1997) The CXXC motif: a rheostat in the active site. *Biochemistry* **36**, 4061-4066.
40. Meyer, Y., Vignols, F. & Reichheld, J.P. (2002) *Methods Enzymol.* **347**, 394-402.
41. Broin, M., Cuine, S., Eymery, F. & Rey, P. (2002) *Plant Cell* **14**, 1417-1432.

42. Kim, S.J., Woo, J.R., Hwang, Y.S., Jeong, D.G., Shin, D.H., Kim, K. & Ryu, S.E. (2003) *J. Biol. Chem.* **278**, 10790-10798.
43. Prinz, W.A., Aslund, F., Holmgren, A. & Beckwith, J. (1997) *J. Biol. Chem.* **272**, 15661-15667.
44. Schürmann, P. & Jacquot, J.P. (2000) *Annu. Rev. Plant Physiol. Plant Mol. Biol.* **51**, 371-400.
45. Zhang, X., Zhang, L., Dong, F., Gao, J., Galbraith, D.W. & Song, C.P. (2001) *Plant Physiol.* **126**, 1438-1448.
46. Mendgen K, Hahn M. (2002) *Trends Plant Sci.* **7**, 352-356.
47. Do, H.M., Hong, J.K., Jung, H.W., Kim, S.H., Ham, J.H., Hwang, B.K. (2003) *Mol. Plant Microbe Interact.* **16**, 196-205.
48. Nathan, C. & Shiloh, M.U. (2000) *Proc. Natl. Acad. Sci. USA* **97**, 8841-8848.
49. Levine, A., Tenhaken, R., Dixon, R. & Lamb, C. (1994) *Cell* **79**, 583-593.
50. Delledonne, M., Zeier, J., Marocco, A. & Lamb, C. (2001) *Proc. Natl. Acad. Sci. USA* **98**, 13454-13459.
51. Mellersh, D.G., Foulds, I.V., Higgins, V.J. & Heath, M.C. (2002) *Plant J.* **29**, 257-268.

### **Figure legends**

Fig. 1. Alignment of poplar Prx Q with homologous proteins using ClustalW. Accession numbers are xxxxx for the *Populus tremula* x *P. tremuloides* Prx Q (Pop trem), BAA90524 for *Sedum lineare* (Sed line), BAB01069 for *Arabidopsis thaliana* (Ara thal), NP\_487223 for *Nostoc sp. PCC 7120* (Nos pcc7), NP\_343463 for *Sulfolobus solfataricus* (Sul solf), P23480 for *Escherichia coli* (Esc coli), CAA86239 for *Saccharomyces cerevisiae* (Sac cere). The arrow represents the site of truncation of the poplar sequence.

Fig. 2. A : SDS PAGE 15% analysis of the recombinant Prx Q proteins. Poplar Prx Q WT (lanes 1 and 4), Prx Q C46S (lanes 2 and 5) and Prx Q C51S (lanes 3 and 6) in reducing conditions (10 mM DTT, lanes 1, 2, 3) and in non reducing conditions (lanes 4, 5, 6).

B : Non reducing SDS PAGE showing the formation of heterodimers between Prx Q C51S and Trx m C40S. Lane 1 : Prx Q C51S-TNB, lane 2 : Prx Q C51S-TNB + Trx m C40S, lane 3 : Trx m C40S, lane 4 : Prx Q C51S-TNB + Trx m C40S + 10 mM DTT. The star represents the heterodimer between Prx Q C51S and Trx m C40S, a and c are respectively monomer and dimer of Trx m C40S, b and d are respectively monomer and dimer of Prx Q C51S.

Fig. 3. Time course of H<sub>2</sub>O<sub>2</sub> reduction mediated by the recombinant WT Prx Q and various Trx in the presence of DTT. Open squares : Trx h2, closed squares : Trx h1, open circles : spinach Trx m, closed circles spinach Trx f, open triangles : Trx h1 and close triangles : poplar Grx, cyclophilin A DTT alone, minus Trx, minus Prx Q.

Fig. 4. Trx or Grx dependent peroxidase activity of Prx Q WT, C51S or C46S.

The peroxidase activity was measured with 500 μM H<sub>2</sub>O<sub>2</sub>, 5 μM of either WT Prx Q (columns 1, 4, 7) or Prx Q C46S (2, 5, 8) or Prx Q C51S (3, 6, 9), in the presence of 5 mM DTT with 50 μM of either WT Grx (columns 1, 2, 3), or Grx C30S (4, 5, 6) or Trx h1 WT (7, 8, 9). The activity was stopped 5 min after H<sub>2</sub>O<sub>2</sub> addition and expressed as a concentration of consumed H<sub>2</sub>O<sub>2</sub> during 5 minutes. Each experiment was repeated three times. Background values of the reactions are in the order of 50 μM.

Fig. 5. Oxidation-reduction properties of Prx Q. A. Oxidation-reduction titration of Prx Q at pH 7.0. Each reaction mixture contained 100 μg of Prx Q in 1.0 ml of 100 mM MOPS buffer (pH 7.0) containing DTT at a total concentration of 2.5 mM (E<sub>h</sub> was adjusted by varying the ratio of reduced:oxidized DTT). Samples were equilibrated for 3.0 hours before the addition of mBBBr. B. Effect of pH on the E<sub>m</sub> value of Prx Q. Reaction conditions were as in (A) except for the pH buffers used (see Methods).

Fig. 6. Chloroplast localization of the fusion protein comprising the N-terminal sequence of Prx fused to GFP. 1- Image of stomata from *Nicotiana bentamiana* under visible light. Only the lower guard cell was transfected. 2- Autofluorescence of chlorophyll (red). 3- Fluorescence of the fusion protein (green). 4- Merged images.

Fig. 7. Immunogold labelling of Prx Q in a chloroplast of mesophyll cells from light grown poplar leaves.

Fig. 8. Expression pattern of poplar Prx Q in plant organs or in response of *Melampsora larici-populina*.

Western blot showing the expression of Prx Q in leaves (L), stems (S) or roots (R) (A), and during an incompatible reaction between 0 and 72 hours (B), a compatible reaction between 0 and 24h and 10 days after infection (C) or in non treated plant (D).

	kcat (s <sup>-1</sup> )	Km (μM)	kcat/Km (x10 <sup>3</sup> M <sup>-1</sup> s <sup>-1</sup> )	Vmax (μmoles NADPH ox min <sup>-1</sup> μmoles <sup>-1</sup> ) (μmoles NADPH ox min <sup>-1</sup> mg protein <sup>-1</sup> )
H <sub>2</sub> O <sub>2</sub>	2.93	367 ± 37 ;5	7.98	176 (10.46)
tBOOH	0.896	375.2 ± 125.7	2.39	53.76 (3.19)
CUOOH	2.35	98.8 ± 19.1	23.78	141.12 (8.38)

Table I : Catalytic parameters of WT Prx Q vs various hydroperoxides

These parameters were determined by following the NADPH oxidation in the presence of 1μM WT Prx Q. The apparent Km for the various hydroperoxides was measured at saturating concentrations of Trx h3. The Km of Prx Q for Trx h3 is 1.5 μM.

Pop trem ----MASISLPKHSLPSSLPTLKPITSSSQNLPILSKSSSQSQFYGLKFSHSTSLSIPS 54  
 Sed line -----QTLQTSSSQSQFHGLKFSHASSFKSPS 54  
 Ara thal MAASSSSFTLCNHTTLRTLPLRKTLLVTKTQ-FSVPTKSSESNFFGSTLTHSSYISPVS 57  
 Nos pcc7 -----  
 Sul solf -----  
 Esc coli -----  
 Sac cere -----MGEALRRSTRIAISKRMLEEEESKLAPISTPEVPPKKIKTGPKHNANQAVVQ 52



Pop trem SSSVKNTIFAKVKNKGQAPPSFTLKDQDGKTLSSLKFKGK--PVVVYFYPADETPGCTK 110  
 Sed line APLRKNSIFAKVTKGSTPPPFTLKDQEGRPVSLSKFKGK--PVVVYFYPADETPGCTK 110  
 Ara thal SSSLKGLIFAKVKNKGQAAPDFTLKDQNGKPVSLKKYKGGK--PVVLYFYPADETPGCTK 113  
 Nos pcc7 -----MPVKVGD SAPDFTLPAQNGSSVLSDFRGKK-AVVLYFYPKDDTPGCTA 48  
 Sul solf -----MVKVGDKAPLFEGIADNGEKISLSDYIGKH-NIVLYFYPKDDTPGCTR 47  
 Esc coli -----MNPLKAGDIAPKFSLPDQDGEQVNLDFQGG--RVLVYFYPKAMTPGCTV 48  
 Sac cere EANRS-SDVNELEIGDPIPDLSLLNEDNDSISLKKITENNRVVVFFVYPRASTPGCTR 109

\* \* \* \* \*

Pop trem QACAFRDSYEKFKKAGAEVVGISGDDPSSHKAFAKKYRLPFTLLSDEGNKIRKEWGV 168  
 Sed line QACAFRDSYEKFKKAGAEVVGISGDSSESHKAFAKKYKLPFTLLSDEGNKVRKEWGV 168  
 Ara thal QACAFRDSYEKFKKAGAEVIGISGDDSASHKAFAKKYKLPYFTLLSDEGNKVRKDWGV 171  
 Nos pcc7 ESCAFRDRYEVFQTAGAEIIGVSGDSNESHQKFAKYNLFPFTLLSDKGDQVRKLYGAT 106  
 Sul solf EACAFRDNWDLKDYDVVVIGVSSDDINSHKRFKEKYKLPFILVSDPKKIRELYGAK 105  
 Esc coli QACGLRDNMDELKKAGVDVLGISTDKPEKLSRFAEKELLNFTLLSDEDHQVCEQFGVW 106  
 Sac cere QACGFRDNYQELKKY-AAVFGLSADSVTSQKKFQSKQNLPHYLLSDPKREFIGLLGAK 166

\* \* \* \* \*

Pop trem AD---LFGTLPG--RQTYVLDKKGVVQLIYNNQFQPEKHIDETLKLQSL----- 213  
 Sed line SD---LFGTLPG--RETYVLDKNGVVQLVYNNQFQPEKHIDETLKLQSLK----- 214  
 Ara thal GD---LFGALPG--RQTYVLDKNGVVQLIYNNQFQPEKHIDETLKLFLKAA----- 216  
 Nos pcc7 A---AFGLFPG--RVTYVIDQQGVVQYVFDSMFNFQGHVEEALKTLQQLASK--- 153  
 Sul solf G-----FILPA--RITFVIDKKGIIIRHIYNSQMNPNANHVNEALKALKQIKEEEIS 153  
 Esc coli GEKSFMGKTYDGIHRISFLIDADGKIEHVFD-DFKTSNHHDVVLNWLKEHA----- 156  
 Sac cere KTP--LSGSIRS--HFIFVDGKLFKRVKISPEVSVNDAKKEVLEVAEKFKEE--- 215

\*



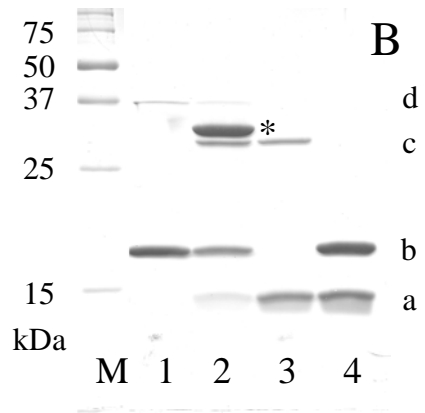
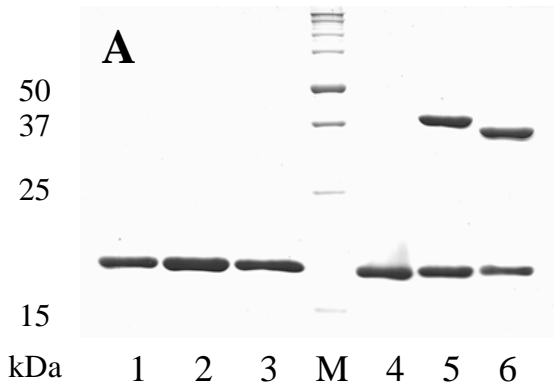

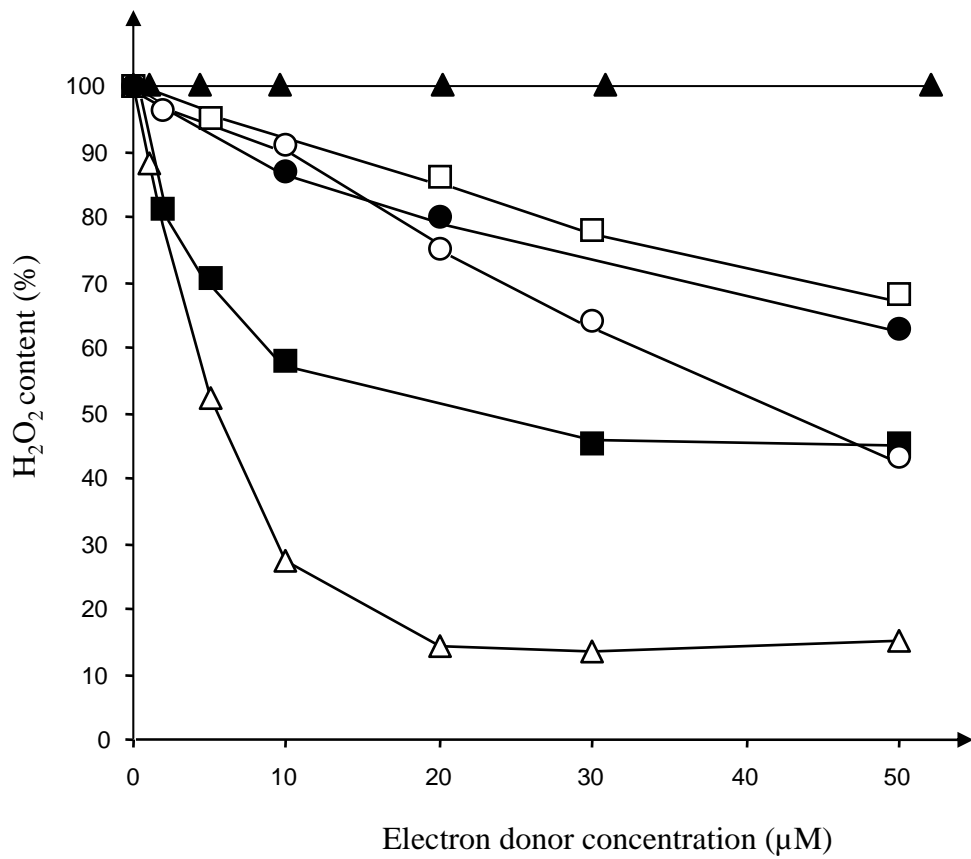

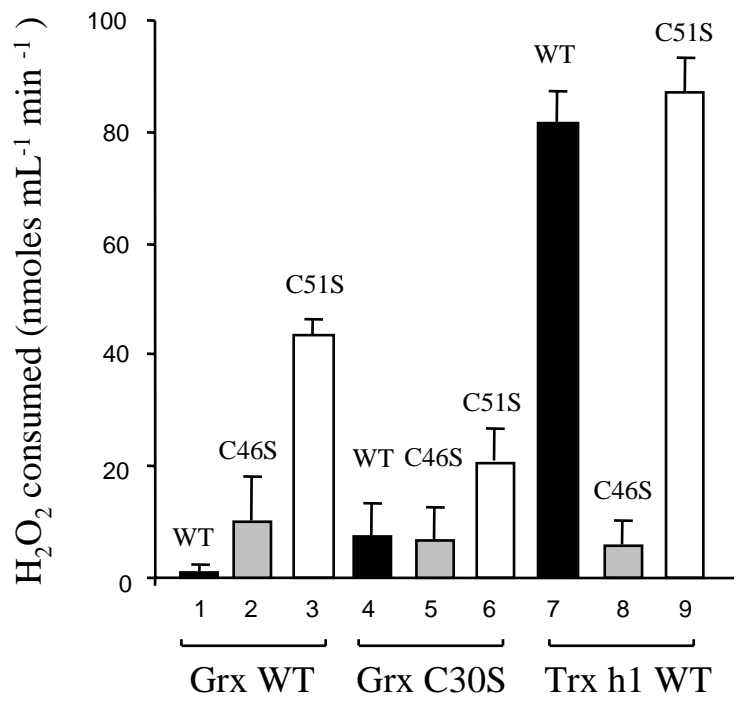

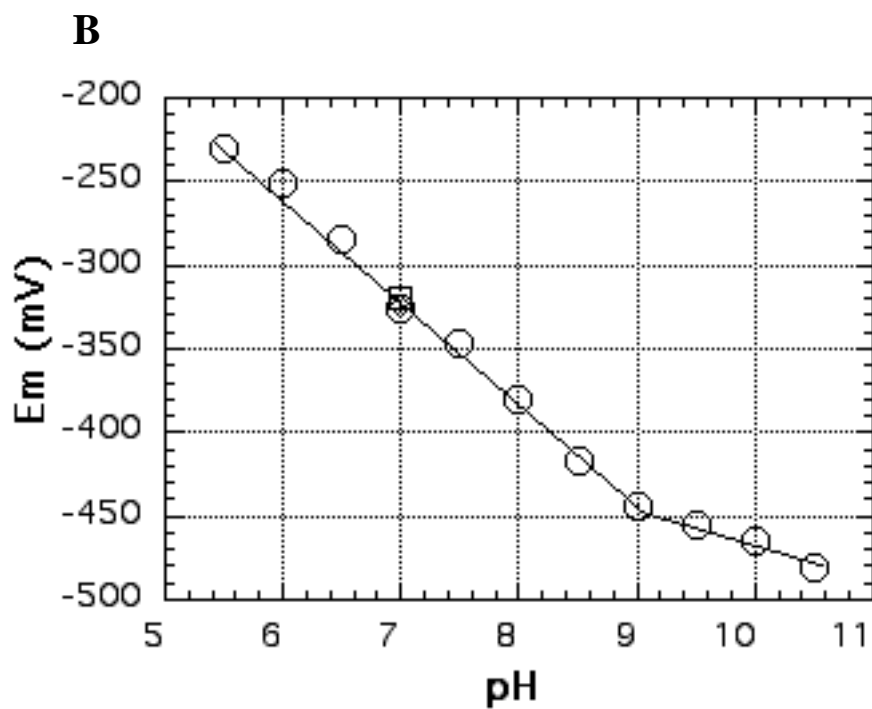
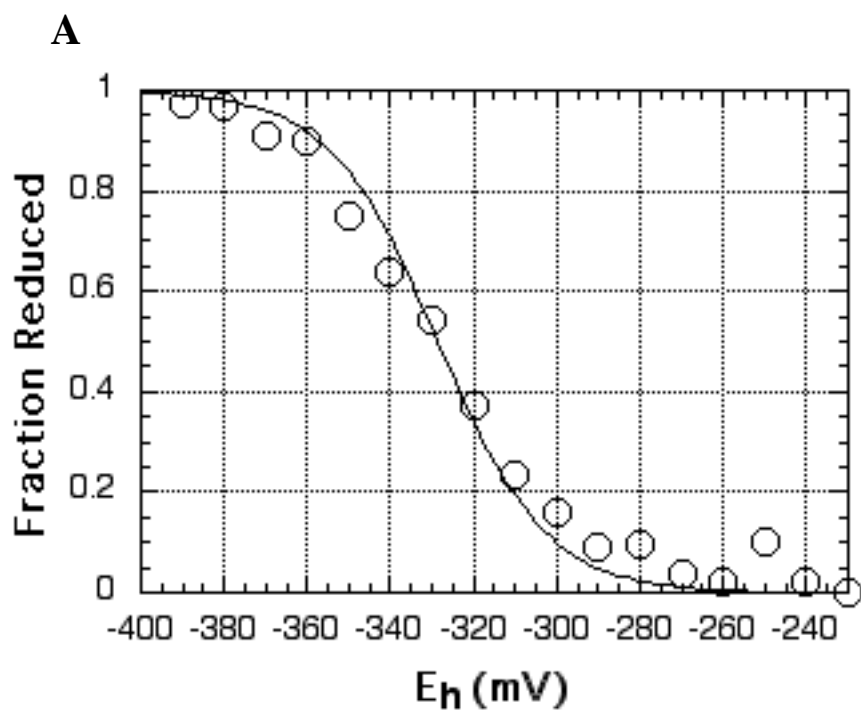

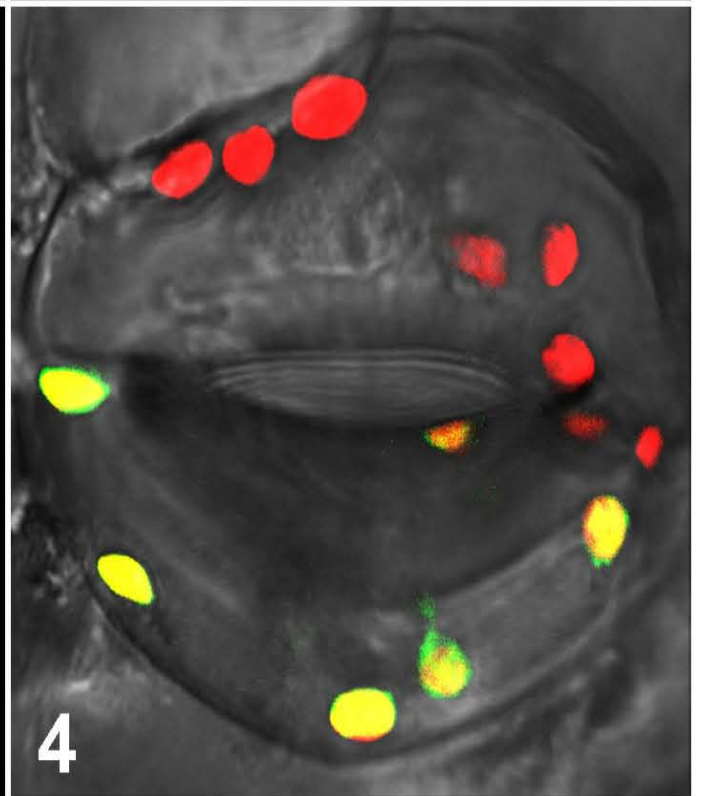
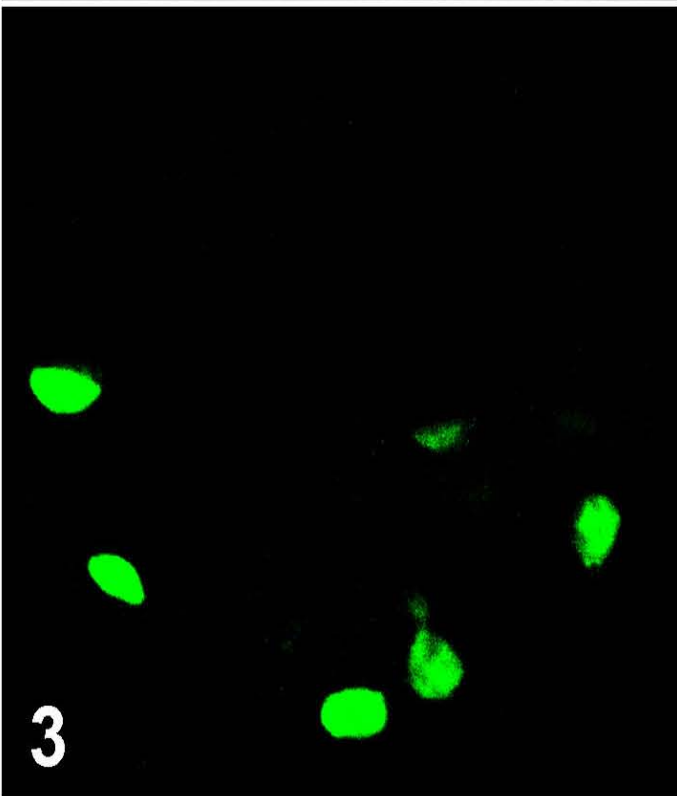
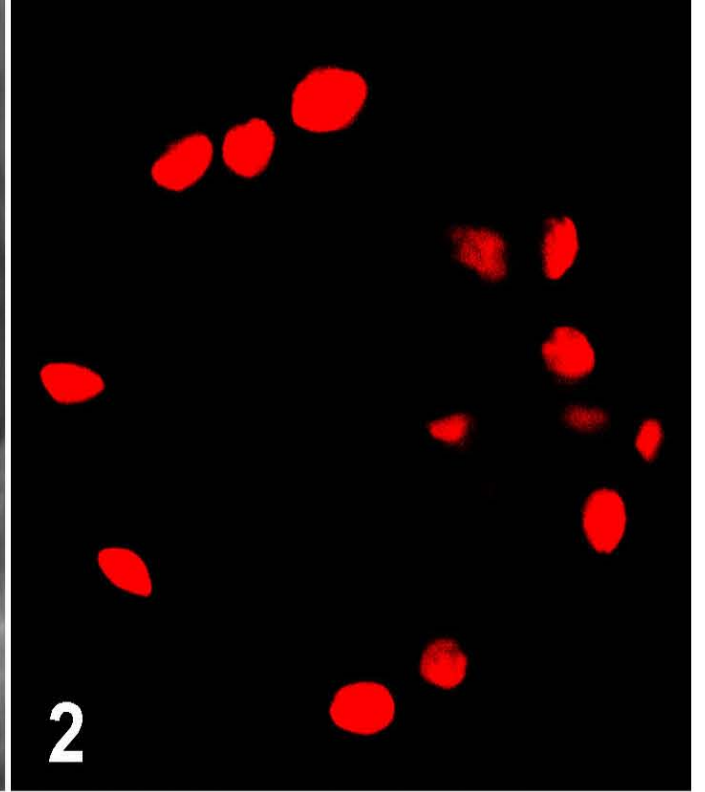
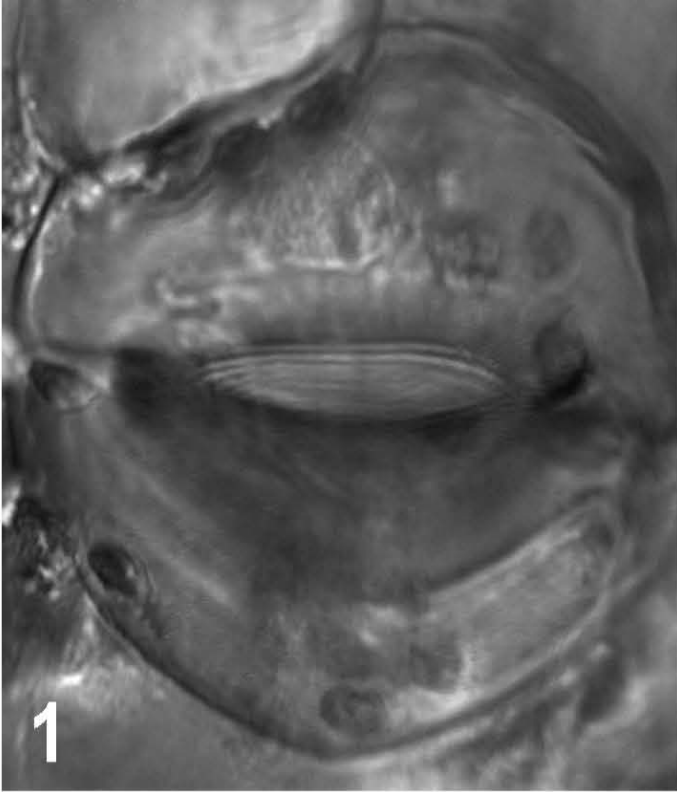

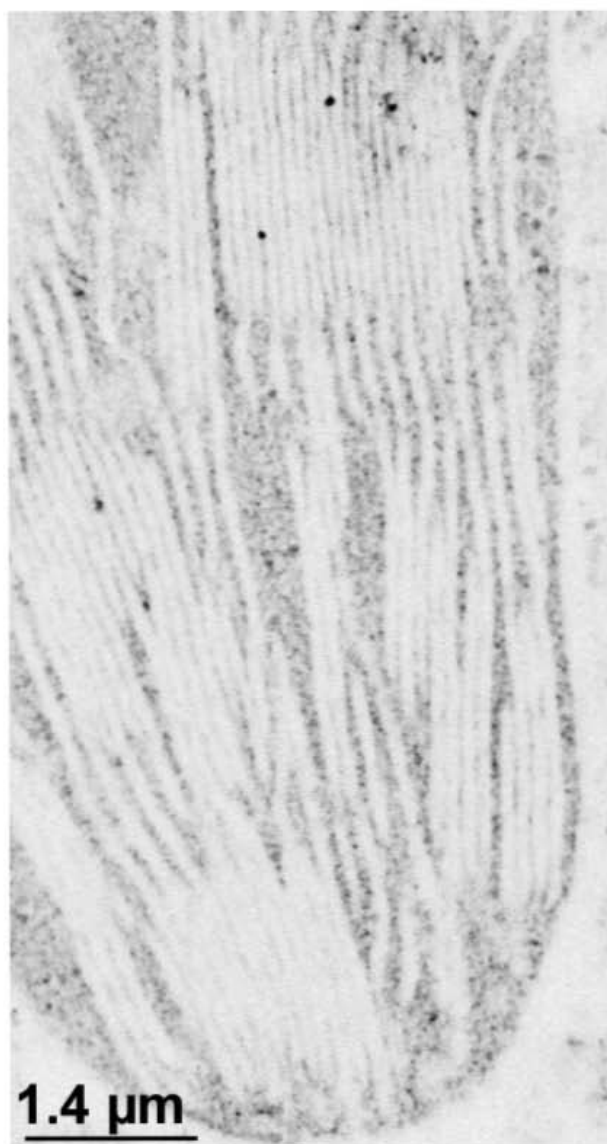

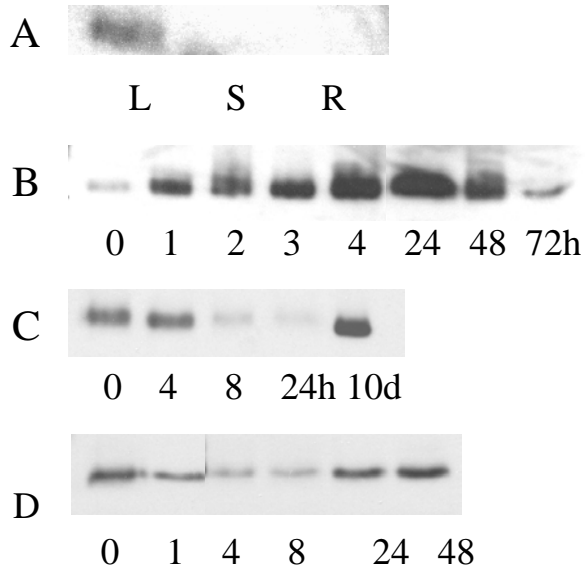

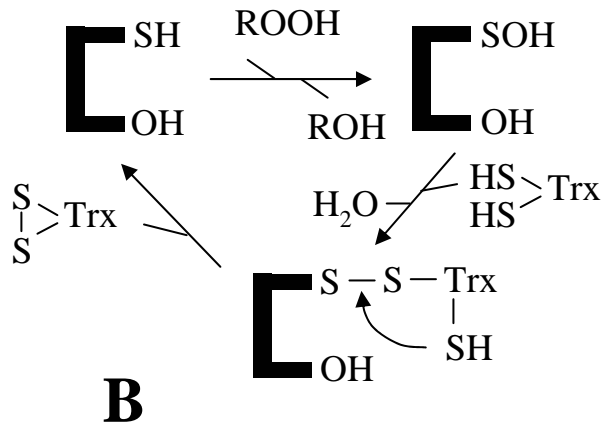
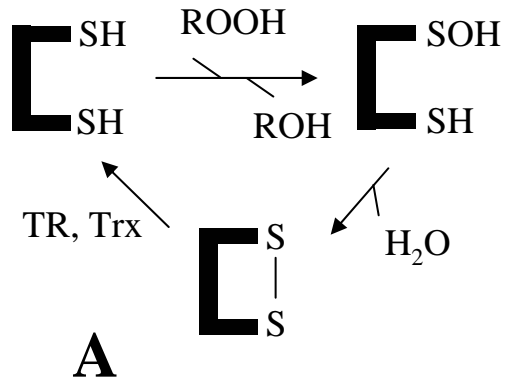



Article numéro 16 :

**Rouhier N, Kauffmann B, Tete-Favier F, Paladino P, Gans P, Boschi-Muller S, Branlant G, Aubry A, Jacquot JP.**

*Functional and structural aspects of poplar cytosolic and plastidial type A methionine sulfoxide reductases.*

**En préparation**

Deux isoformes de MsrA de peuplier, une MsrA cytosolique (cMsrA) et une plastidiale (pMsrA) sans son peptide de transit ont été exprimées chez *E. coli*. Les protéines recombinantes sont monomériques et possèdent une activité de réduction de la méthionine sulfoxyde (L-R,S MetSO). Différents types de MsrA existent selon le nombre et la position des cystéines impliquées dans la catalyse (voir introduction). Les deux MsrA de peuplier possèdent cinq cystéines en position conservée (31, 66, 85, 182 et 188 pour la cMsrA et 46, 81, 100, 196 et 202 pour la pMsrA). Les cinq cystéines de la cMsrA ont été mutées une à une et les trois cystéines 46, 196 et 202 de la pMsrA également. Les protéines sauvages possèdent une activité de réduction de la MetSO en Met dépendante des Trx cytosoliques Trx h1 et h3 mais pas des Grx. Les mutants cMsrA C66S et C85S conservent également cette activité suggérant que ces cystéines ne sont pas essentielles à la catalyse. Par contre, tous les autres mutants sont inactifs avec les Trx. Par ailleurs, pour déterminer le rôle de chacune de ces cystéines, le contenu en thiols libres de ces mutants a été estimé en présence et en absence de MetSO et la stoechiométrie d'apparition de la Met de ces différents mutants analysés en présence d'une concentration connue de MsrA réduite. Les résultats obtenus indiquent que la cystéine 31 ou 46 selon l'isoforme considérée est la cystéine catalytique et que les cystéines 182 et 188 ou 196 et 202 participent à la régénération Trx dépendante de l'enzyme, selon un mécanisme identique à la MsrA d'*E. coli*. Par ailleurs, la structure cristallographique de la pMsrA a pu être résolue. Cette structure démontre que comme pour les autres structures de MsrA déterminées jusqu'à présent, un important réarrangement est indispensable pour la formation des ponts disulfures nécessaires à la réduction de l'enzyme.

## **Functional and structural aspects of poplar cytosolic and plastidial type A methionine sulfoxide reductases**

Nicolas Rouhier<sup>1\*</sup>, Brice Kauffmann<sup>2\*</sup>, Frédérique Tete-Favier<sup>2</sup>, Pasquale Paladino<sup>2</sup>, Jérémie Couturier<sup>1</sup>, Pierre Gans<sup>4</sup>, Sandrine Boschi-Muller<sup>3</sup>, Guy Branlant<sup>3</sup>, André Aubry<sup>2</sup> and Jean-Pierre Jacquot<sup>1,5</sup>

<sup>1</sup>Unité Mixte de Recherches 1136 INRA Université Henri-Poincaré, Interactions Arbres Microorganismes. Faculté des Sciences BP 239 54506 Vandoeuvre Cedex France

<sup>2</sup>LCM3B, Groupe de Biocristallographie, UMR CNRS 7036, Université Henri-Poincaré, Faculté des Sciences BP 239 54506 Vandoeuvre Cedex France

<sup>3</sup>Laboratoire MAEM, Université Henri Poincaré, Faculté des Sciences BP 239 54506 Vandoeuvre Cedex France

<sup>4</sup>Laboratoire de Résonance Magnétique Nucléaire. Institut de Biologie Structurale CEA-CNRS-UJF "Jean-Pierre Ebel" 38027 Grenoble Cedex 1.

<sup>5</sup>Corresponding author : Tel ++ 33 3 83684225, email : j2p@sbiol.uhp-nancy.fr

\*These two authors have equally contributed to the work.

Running title: Structure and function of plant MsrA

Keywords : methionine sulfoxide reductase/mutagenesis/poplar/structure/thioredoxin

## **Abstract**

This study presents new data concerning the molecular functioning and structure of plant type A methionine sulfoxide reductases (MsrA). Both cytosolic and plastidial poplar MsrA were analyzed. The enzymes are highly homologous, monomeric and active in the reduction of methionine sulfoxide with either dithiothreitol or poplar thioredoxins as a reductant. In both enzymes, five conserved cysteines are found in positions 31, 66, 85, 182 and 188 (cytosolic isoform numbering). Site-directed mutagenesis indicates that three cysteines are involved in catalysis/regeneration by thioredoxin: Cys 31, the catalytic cysteine and the two C-terminal cysteines Cys 182 and 188. As observed with other MsrA, in the tridimensional structure of the plastidial enzyme, the three cysteinyl residues are far apart, but molecular modelling suggests the presence of two hinges that could provide the needed flexibility of the C-terminal part.

## Introduction

In aerobic organisms, various oxidants can damage macromolecules including proteins, nucleic acids and unsaturated lipids (Storz and Imlay, 1999). All the amino acids are susceptible to oxidation, although some of them are more easily damaged (Stadtman, 1993). The two sulfur containing amino acids, cysteine and methionine, are exposed to various reversible or irreversible oxidations (Cooper *et al.*, 2002; Brot and Weissbach, 2000). To counter these deleterious effects, living organisms have developed an array of antioxidative enzymes either to directly detoxify the reactive oxygen or nitrogen species (ROS or RNS) or to repair the damages induced.

Methionine residues can be oxidized reversibly into methionine sulfoxide (MetSO) or irreversibly into methionine sulfone (Brot and Weissbach, 2000). Ubiquitous enzymes called methionine sulfoxide reductases (Msr) are able to reduce free or peptide bound MetSO into methionine (Brot *et al.*, 1981). This reduction is achieved with the help of the thioredoxin (Trx) system (Gonzales Porque *et al.*, 1970; Russel and Model, 1986). Based on the stereoselectivity vs the two diastereoisomers of MetSO, L-S-MetSO or L-R-MetSO, and the catalytic mechanism of the enzymes, two types of Msr can be distinguished. Type A Msr (MsrA) specifically reduces the S enantiomer whereas type B Msr (MsrB) only reduces the R enantiomer (Moskovitz *et al.*, 2000; Sharov *et al.*, 2000; Grimaud *et al.*, 2001). Moreover, recent studies using protein extracts of a double mutant MsrA/MsrB of *Escherichia coli* indicate that *E. coli* possesses in addition a Msr isoform able to reduce free R-MetSO, another one which would reduce only the S-MetSO in a peptide linkage and finally, a membrane bound associated activity of reduction of R or S-MetSO in peptides (Etienne *et al.*, 2003; Spector *et al.*, 2003). In some organisms such as bacteria of the *Neisseria* genus, both MsrA and MsrB modules are fused in tandem and the protein called PILB possesses the two activities (Lowther *et al.*, 2002; Olry *et al.*, 2002; Kryukov *et al.*, 2002). In mammals, MsrB are selenoproteins and sometimes zinc containing proteins, whereas only one isoform of MsrA from *Chlamydomonas reinhardtii* was found to contain a selenocysteine and no MsrA isoforms were shown to have a bound metal or cofactor (Novoselov *et al.*, 2002).

The catalytic mechanisms of multiple cysteine-containing MsrA and MsrB are similar despite the low sequence identity between the two proteins. The first step in catalysis is the formation of a transient sulfenic acid. Subsequently, the regeneration of the active site involves the formation of one or two disulfides which comprise the catalytic cysteine and one or two additional cysteines. Ultimately, the latest disulfide bond is reduced by Trx (Lowther

*et al.*, 2000; Boschi-Muller *et al.*, 2000; Jung *et al.*, 2002; Kumar *et al.*, 2002). The catalytic cysteine of MsrA is present in the consensus sequence GCFW[G/C/S]. Despite their identical functions, MsrA and MsrB are structurally different but the active sites display a similar organization and catalysis occurs through similar mechanisms (Tete-Favier *et al.*, 2000; Lowther *et al.*, 2002).

The cyclic oxidation/reduction of methionine residues is a pathway known to regulate the function of some proteins such as calmodulin or potassium channels (Yao *et al.*, 1996; Ciorba *et al.*, 1997). Moreover, this phenomenon seems to play a role in the antioxidant defense because Msr can repair damages caused to methionine residues (Moskovitz *et al.*, 1997; Moskovitz *et al.*, 1998; Levine *et al.*, 2000; Stadtman *et al.*, 2002). MsrA are also involved in pathogenicity processes probably by promoting cell adherence or by degrading ROS or RNS (Wizemann *et al.*, 1996; Hassouni *et al.*, 1999; Dhandayuthapani *et al.*, 2001; St John *et al.*, 2001).

In plants, the complete sequencing of the *Arabidopsis thaliana* genome leads to the identification of at least four MsrA, one chloroplastic and three cytosolic enzymes. A cytosolic and a chloroplastic enzyme from *A. thaliana* are active in the reduction of MetSO in the presence of dithiothreitol (DTT) (Sadanandom *et al.*, 2000). The gene encoding the cytosolic isoform was found to be expressed in nearly all plant tissues and to respond to a pathogen infection by the cauliflower mosaic virus whereas the gene encoding the plastidial isoform is only expressed in photosynthetic tissues, regulated by light and prevents the inactivation of a small heat shock protein (Hsp21) (Sadanandom *et al.*, 2000; Gustavsson *et al.*, 2002).

Previous reports on the plant enzymes have focused essentially on the expression pattern of MsrA, but the functioning and structure of the enzymes have not been addressed. This work describes the biochemical properties and the catalytic mechanism of two poplar MsrA. Site-directed mutagenesis of cysteine residues was used to elucidate which cysteines of the plant MsrA are implicated in the reduction of S-MetSO and in the regeneration into a reduced and catalytically active form by thioredoxins. Moreover, two isoforms of Trx have been tested to investigate the efficiency of putative physiological reductants with the two MsrA. In addition, the first structure of a plant MsrA is described and discussed in relation with the biological activity.

## Results

### *Sequence analysis*

Two isoforms of Populus MsrA, a chloroplastic isoform that we call here conveniently pMsrA (plastidial MsrA) and a cytosolic isoform cMsrA (cytosolic MsrA), were isolated from poplar leaf and root cDNA libraries respectively. Based on transit peptide prediction programs and amino acid comparisons with homologous proteins from *Arabidopsis thaliana*, pMsrA (259 amino acids for the precursor) is predicted to present a 56 amino acids long N-terminal chloroplastic transit peptide (Sadanandom *et al.*, 2000). The size of the mature recombinant pMsrA devoid of the transit peptide produced here is 22980 Da (204 amino acids including the initial methionine and an alanine adding for cloning facility) and the theoretical pI is 5.8. The *cmsra* open reading frame encodes a protein of 190 amino acids with a molecular weight of 21271 Da and a theoretical pI of 6.12. The identity between the mature pMsrA and cMsrA poplar isoforms is 62%. It ranges from 58 to 82% within the plant sequences and from 32 to 40% vs the *Escherichia coli* and *Bos taurus* enzymes, two proteins for which cristallographic structures have been elucidated (Figure 1). As the cysteine residues are recognized as critical for the functioning of MsrA, it is interesting to comment on their positions in the plant sequences. In the poplar cytosolic enzyme, four of the five cysteines (Cys 31, 66, 182, 188) are found in positions strictly conserved by comparison with the other plant sequences, whereas the cysteine in position 85 is replaced by a valine in the *Brassica* pMsrA. Interestingly, this residue has no equivalent in *E. coli* or *Bos taurus* MsrA which contain the four other cysteines in conserved positions (Lowther *et al.*, 2000; Boschi-Muller *et al.*, 2000). The five cysteine residues of pMsrA (Cys 46, 81, 100, 196 and 202) are in the same position than in cMsrA.

### *Methionine sulfoxide reductase activity*

The two poplar MsrA isoforms were produced as recombinant proteins and purified to homogeneity. The methionine sulfoxide reductase activity of the two poplar MsrA isoforms was first measured by high pressure liquid chromatography (HPLC) with DTT as a donor, and both enzymes were found to be catalytically active (data not shown). This was confirmed using a spectrophotometric test by following the NADPH oxidation in the presence of two reducing systems, the Trx (NADPH/ NADPH thioredoxin reductase/ Trx) or glutaredoxin (Grx) (NADPH/ glutathione reductase/ reduced glutathione/ Grx) systems. The Grx system was inefficient to reduce both WT MsrA (data not shown). Table I presents the kinetic

parameters of both enzymes obtained in the presence of two cytosolic poplar Trx (Trx h1 and Trx h3). The affinities of the two isoforms for Trx or L Met-R,S-SO are nearly identical and apparent  $K_m$  values are respectively around 15 to 18  $\mu\text{M}$  and 200 to 400  $\mu\text{M}$ . The catalytic efficiency, expressed as  $k_{\text{cat}}/K_{\text{MetSO}}$ , was around 3 fold higher at pH 8.0 for cMsrA vs pMsrA. Given the high sequence identity between the two enzymes, the difference in specific activity between the two enzymes is a bit surprising. It could result either from a dissymmetry in the pH optimum of the two isoforms or from the distorting of the active site or from a lower efficiency of the cytosolic Trx used here with the plastidial enzyme, despite an apparent similar affinity. In order to discriminate between these possibilities, we used DTT as a donor instead of Trx in a direct determination of either MetSO or Met content by NMR. The concentration of these two species was obtained from the intensity of the resonances signals at 2.15 ppm and 2.65 ppm corresponding to the Met methyl resonance and the MetSO methyl resonance, respectively. As illustrated in Figure 2, addition of either cytosolic or plastidial MsrA results in a rapid decrease of the MetSO concentration (Figure 2A) concomitant with the apparition of Met (Figure 2B). When analyzed at pH 8.5, cMsrA was also approximately 3 fold more active than the pMsrA, suggesting that the cytosolic Trx h1 is a poor donor for the pMsrA. In agreement with the known stereoselectivity of MsrA species, we observe that only the L-Met-S-SO is reduced by the pMsrA or cMsrA. This is shown by the diminution of only one half of the MetSO initial content after completion of the reaction.

In order to investigate the catalytic mechanism of the two enzymes, the cysteine residues were independently mutated into serines. As cMsrA possesses a higher catalytic turnover in the coupled assay, the mutations of the five cysteines have been performed preferentially on this protein. In addition, the three cysteines presumed to be involved in the catalytic mechanism were also mutated in pMsrA. Only cMsrA C66S and C85S mutants retain activity with Trx as reductant (data not shown). The mutation of Cys 31, the conserved cysteine in all MsrA, and of Cys 182 and 188, the two C-terminal cysteines, completely abolished the Trx-dependent regeneration of the enzyme. These results suggest that Cys 66 and 85 are not involved in catalysis in contrast to Cys 31, 182 and 188. In agreement with these results, the pMsrA C46S, C196S and C202S mutants are inactive in the Trx-dependent assay (data not shown). The two mutants cMsrA C31S and pMsrA C46S were also found to be totally inactive in the presence of DTT in the NMR assay (Figure 2). To determine the sequence of events involving these three cysteines in methionine sulfoxide reduction, the stoichiometry of the reaction was measured by following the methionine formed at a fixed concentration of reduced MsrA without any other reductant using HPLC. In the hypothesis of

a mechanism similar to the one of *E. coli* MsrA, the stoichiometry is assumed to be two moles of methionine formed per mole enzyme for cMsrA WT enzyme, cMsrA C66S and cMsrA C85S, only one for cMsrA C182S and C188S and none for the C31S mutant. Table II shows the results obtained with the poplar enzymes. The WT cMsrA and pMsrA present a stoichiometry near 2 as expected based on the presumed catalytic mechanism. The cMsrA C66S and C85S mutants reduce only 1.4 moles of Met per mole enzyme instead of the 2 expected presumably because part of these enzymes was in an oxidized form. The cMsrA C31S mutant is totally inactive as it reduces 0 moles of Met per mole enzyme, whereas the cMsrA C182S and C188S mutants possess a stoichiometry of 1.16 and 1.68 respectively instead of the expected value of 1. From these data, Cys 31 is the catalytic cysteine but whether Cys 182 and Cys 188 are both involved in the Trx dependent regeneration is not clear. In order to gain additional information about the involvement of the Cys182 and Cys188 in catalysis, the thiol content of each recombinant protein was estimated after reduction in the presence or absence of an excess of L Met-R,S-SO (Table III). For the pMsrA WT, C46S, C196S and C202S mutants, the decrease in free thiol groups matches well the theoretical values assuming an attack of Cys 46 by MetSO to form a sulfenic acid which is then reduced by disulfide bonding with Cys 196, the resulting disulfide bond being finally reduced by Cys 202. For the cMsrA mutants, the results also essentially agree with the postulated mechanism within the uncertainty inherent to thiol measurement.

### **Overall structure of pMsrA**

Crystallisation trials were performed for both chloroplastic and cytosolic MsrA, but crystals of sufficient dimension for X-Ray analysis were obtained only for the pMsrA form. The trigonal crystals (space group  $P3_1$ ) contain one molecule per asymmetric unit and 45% of solvent, and diffract to 1.7Å resolution (Table IV and V). The structure was solved and refined with final R- and free-R-factors of 19.5 and 20.1%, respectively. Superimposition of the poplar pMsrA with the *E. coli* and the bovine structures (PDB entries : 1FF3 and 1FVA, respectively) (Tete-Favier *et al.*, 2000; Lowther *et al.*, 2000) shows that the cores of the three enzymes possess the same overall fold as expected from the sequence identity between these enzymes (Figure 3), while the long N and C-terminal ends display the following substantial differences:

- The core of the MsrA structure starts at the first  $\beta$ -strand, S1, at the end of which is found the GCFWG footprint containing the catalytic cysteine residue Cys46, and ends 3 amino



acids after the AExxHQx $\phi$  footprint, next to the last  $\beta$ -strand S6 (see Tete-Favier *et al.*, 2000 for secondary structure numbering). Selecting the corresponding amino acids, Gln37 to Lys182 in pMsrA, Met42 to Lys192 in the *E. coli* MsrA, and Thr63 to Lys212 in the bovine MsrA, C $_{\alpha}$  atoms can be superimposed with a root mean square distance (rmsd) of 0.800 Å for the poplar/*E. coli* pair and with an rmsd value of 0.874 Å for the poplar/bovine pair.

- In the *E. coli* MsrA, the long N-terminal end coils up around the core of the domain. It is constituted of 41 amino acids, the first seven residues being observed in different conformations in the three monomers of the asymmetric unit. In the bovine MsrA model, in which amino acids 1 to 27 are not present, residues 28 to 62 display the same overall conformation than in the *E. coli* enzyme. In the pMsrA structure, only residues Pro22 to Gly36 of the N-terminal end were observed in the electron density. Their positions strongly differ from those observed in the *E. coli* and bovine MsrA structures (Figure 3). The coil is hydrogen-bonded via the main chains to the extended segment that links S5 to S6. This different position of the N-terminal end arises from the sequence of the hinge region connecting the N-terminal end to the core of the enzyme: <sup>35</sup>Pro-Gly<sup>36</sup> is present in poplar, while it is <sup>40</sup>Asp-Gly<sup>41</sup> in *E. coli*, and <sup>61</sup>Glu-Gly<sup>62</sup> in the bovine enzyme. The missing residues <sup>1</sup>Met-Asp<sup>21</sup> are very disordered since no electron density is observed upstream from Pro22, and are probably situated in the large solvent cavity observed near Pro22.
- The <sup>193</sup>Asn-Ala<sup>211</sup> C-terminal end of the *E. coli* MsrA was observed in only one monomer among three in the asymmetric unit, leading to conclude to its flexibility. Despite the presence of an intermolecular disulfide bridge involving Cys202 that could have forced the C-terminal end to adopt an unlikely conformation in the *E. coli* model, it is surprising to observe a similar position of the <sup>213</sup>Asp-Pro<sup>228</sup> C-terminal end in the bovine MsrA structure. The extended coil runs above the active site and then antiparallel to  $\alpha$ -helices H2 and H3. In the pMsrA model, the <sup>183</sup>Gly-Gly<sup>204</sup> C-terminal end is folded in a completely different way (Figure 3) : it consists of a coil that runs first parallel to the  $\alpha$ -helix H1 and then, after a turn, antiparallel to it (Figure 4). Numerous hydrogen bonds are observed inside this C-terminal part, and between the C-terminal part and the core of the domain. This region is involved in the crystal packing, since several residues are observed

at the proximity of two symmetry-related monomers. However, the intermolecular contacts seem weaker than the intramolecular contacts.

### ***The active site and the cysteine residues***

As previously observed in the *E. coli* and the bovine MsrA structures, the active site of pMsrA is a large open cavity, which gives high accessibility to the catalytic cysteine residue Cys46. This amino acid, as well as residues Cys196 and Cys202, clearly shows an extra-density on its sulfur atom that was unambiguously modeled as a bonded  $\beta$ -mercaptoethanol, present in the crystallisation solution. Cys81 also possesses an extra-density, however its weaker weight and smallest size have been interpreted as a sulfenic acid (Figure 5). Only Cys100 was observed in its reduced form. It is puzzling to note that neither in the *E. coli* MsrA nor in the bovine enzyme structure, the three cysteine residues involved in the catalytic mechanism are observed in a reduced form.

Two successive intramolecular disulfide bridges are formed in the mechanism of the *E. coli* and the bovine enzymes (Boschi-Muller *et al.*, 2000; Lowther *et al.*, 2000). Sequence alignments point to Cys196 as the residue of pMsrA involved in the first disulfide bridge with Cys46, and Cys202 would then form the consecutive bridge with Cys196. The distance between  $S\gamma_{46}$  and  $S\gamma_{196}$ , 18.0Å, is far from being compatible with the formation of a disulfide bridge. Therefore, the distances between the  $S\gamma$  atoms of the five cysteine residues have been measured (Table VI) in order to evaluate their ability to form disulfide bridges, considering that their current position would be unchanged in an hypothetical structure with five reduced cysteine residues. None of the cysteine pairs, even the narrowest one (Cys46-Cys202, for which the distance observed between the  $S\gamma$  atoms is 7.2Å), is compatible with the formation of a disulfide bridge if no conformational change occurs.

## Discussion

Most of the available data concerning plant MsrA are devoted essentially to expression studies, but unlike in other organisms, little is known about their catalytic mechanism and structural properties (Sadanandom *et al.*, 2002). This paper fills the gap in knowledge concerning the plant enzymes by providing site-directed mutagenesis data together with a first tridimensional structure of a plant MsrA and a catalytic mechanism for poplar MsrA.

### *Catalytic mechanism of poplar MsrA*

Using site-directed mutagenesis, all the five cysteines of cMsrA and the presupposed essential cysteines of pMsrA have been mutated into serines. All the WT and mutated recombinant enzymes are able to reduce MetSO with DTT as a reductant except the cMsrA C31S and pMsrA C46S indicating that these cysteines are the catalytic ones. Moreover, the Trx dependent regeneration was abolished for cMsrA C182S and C188S and unaffected for the cMsrA C66S and C85S mutated proteins suggesting that C66 and C85 do not participate to catalysis whereas the two C-terminal cysteines are involved in the cysteine sulfenic acid reduction of C31. The stoichiometry of the reaction was checked for each recombinant proteins. The results confirm previous observations but do not permit actually to ascertain definitively the involvement of the cysteines C182 and C188 in the Trx dependent reduction. Whether these two cysteines are implicated to form two successive disulfide bridges as for the *E. coli* enzyme, was also assessed by measuring the decrease in free thiol groups of each recombinant protein after MetSO treatment. The data obtained from this experiment confirm with no doubt that C31 (C46 for pMsrA) is the catalytic cysteine which is reduced after attack of the sulfenic acid intermediates by C182 (C196) forming a first disulfide bridge. This disulfide is subsequently attacked by C188 (C202) forming a second disulfide bridge between C182 and C188 (C196 and C202) which will be reduced by Trx but not by Grx as a mechanism similar to the *E. coli* MsrA (Boschi-Muller *et al.*, 2000). Why Grx is not able to reduce this disulfide is not clear actually. Whether the redox potential of the C182-C188 disulfide is too low to be reduced by Grx or whether the interaction could be prevented by steric hindrance or by unadapted surface protein recognition needs to be addressed. Nevertheless, two independent observations are in the favor of a possible Grx dependent regeneration of MsrA in other organisms. First, the growth on MetSO of a methionine auxotroph Trx A<sup>-</sup> *E. coli* strain is restored by Grx 1 overexpression (Stewart *et al.*, 1998). Second, a coding sequence, found in the red algae *Gracilaria gracilis* (accession number

AAD43253), consist of two Grx modules fused with a MsrA module. This module is highly similar to other plant MsrA except for the absence of the cysteine equivalent to the C182 of poplar cMsrA. Whether this protein use a different catalytic mechanism and is reduced by the Grx modules in the presence of glutathione is not known actually.

To gain insight into the interaction between Trx and MsrA, 3D structures of each partner must be resolved at least independently or in complex. Such attempts for linking covalently the two proteins are under investigation. Some heterodimers are observed on non-reducing SDS-PAGE when mixing MsrA and a monocysteinic Trx but the amount is too low to isolate the complex (data not shown).

### ***Structural comparison to other MsrA***

Two structures of MsrA from *E. coli* and *B. taurus* are currently available (Lowther *et al.*, 2000 ; Tete-Favier *et al.*, 2000). The amino acid sequences of these two enzymes are 57% homologous and as a consequence their tridimensional crystallographic structures present extensive homologies. Both enzymes are monomeric, they share a common fold and the core of the protein is similar, but the N and C-termini differ in both structures and none of the cysteines is close enough to the catalytic cysteine to accomodate for the formation of a disulfide bridge. Recent structural data obtained by NMR, which gives a more dynamic picture of the protein, have confirmed that the cysteinyl side chains are indeed not properly located for the formation of the necessary disulfide bridges (Beraud *et al.*, 2002). As a consequence, for both enzymes it has been postulated that important conformational rearrangements are needed or the Trx-mediated regeneration of these enzymes. In connection with these existing data it is obviously of interest to obtain the structure of an additional MsrA.

The structure of the pMsrA from poplar presented here is rather similar to the ones described for the bacterial and mammalian enzymes. All enzymes share the same fold and the catalytic cysteine of the active site is in a similar environment. On the other hand, the orientation and the amino acid composition of the C-terminal part that contains the two additional cysteines implicated in the regeneration process is radically different from the *E. coli* and *B. taurus* MsrA. Indeed, the spacing between the two C-terminal located cysteinyl residues is 5 amino acids for poplar pMsrA instead of 7 or 8 amino acids for the mammalian and bacterial enzymes respectively. Moreover, the high content in glycines between these two cysteines is not present in the poplar enzyme. The C-terminal loop of pMsrA is highly organized with many hydrogen bonds connecting the two parts of the loop whereas it is

poorly structured in the two other models. However as in the other MsrA, the cysteines are in positions that do not allow for the formation of a disulfide bridge. Due to the positions of the monomers in the crystal, it is likely that the conformation of the loop is influenced by the packing of the molecules. In order to understand how the necessary disulfide bridges can be created in pMsrA, molecular modelling studies have been undertaken. The results suggest that there are two hinges in the loop centered on Gly residues (Gly43 and Gly195) that would allow the required movement of the loop for catalysis to occur.

### ***Conclusion***

The data generated here suggest that MsrA enzymes have kept a similar structure and mode of catalysis along evolution. In several cysteine requiring enzymes such as thioredoxin reductase of glutathione peroxidase, the mammalian catalysts have been altered into more complex enzymes that contain selenocysteines. The presence of this residue is generally correlated with a much higher specific activity of the enzyme. Plants are generally recognized as lacking selenocysteines with the notable exception of the green alga *Chlamydomonas reinhardtii* which does contain this unusual amino acid in many catalysts (Novoselov *et al.*, 2002). Analysis of the tridimensional structures of thioredoxin reductases indicates that the plant enzyme (*Arabidopsis thaliana*) is similar to the bacterial enzyme (*E. coli*) but not to the mammalian enzyme. Using this grid of evaluation, plants appear to be closer to bacteria than to mammals. Analysis of the MsrA structures leads to the conclusion that all models of this protein have remained relatively constant along the lines of evolution. It could be correlated to the presence of alternate catalysts as MsrB which seem to have varied more along evolution. The need for several isoforms of MsrA in cytosol of plants is not yet completely clear. The major sources for ROS in plants are likely to be the peroxisomes, chloroplasts and to a lesser extent mitochondria, but few enzymatic systems generate those oxidants in the cytosol. In connection with this observation, it is puzzling that the cytosolic enzyme exhibits a higher catalytic turnover than the plastidial enzyme. It remains to be determined whether this could be compensated by a higher level of expression of the plastidial isoform. Another question to be investigated is whether those enzymes are able to reduce peptide bound MetSO and whether they display a preference for substrates *in vivo* when using oxidized proteins as substrates instead of free L-MetSO.

## Materials and Methods

### *Cloning and site-directed mutagenesis*

The nucleotidic sequences encoding cMsrA and pMsrA were cloned by PCR into the expression plasmid pET-3d using as templates respectively a root cDNA library of *Populus x interamericana* (clone Beaupré) (Kohler *et al.*, in press) and a leaf cDNA library of *Populus tremula x tremuloides* (Larsson *et al.*, 1997). Both reactions also contained Pfu DNA polymerase (Promega) and the forward and reverse MsrA oligonucleotides described in Table VII. In the pMsrA cloning, a codon for alanine was inserted downstream the methionine closest to the putative cleavage site and the corresponding N-terminal amino acid sequence starts thus with MANIL. Various monocysteinic mutations were introduced in the cytosolic MsrA (cMsrA C31S, C66S, C85S, C182S, C188S) and plastidic MsrA (pMsrA C46S, C196S, C202S) using two complementary mutagenic primers per mutation (Table VII) following a procedure previously described (Jacquot *et al.*, 1997). The introduction of the mutation in the cDNA sequence was verified by sequencing.

### *Mutagenesis, expression and purification of the recombinant proteins*

The recombinant plasmids were used to transform the BL21(DE3) *E. coli* strain which also contains the helper plasmid pSBET (Schenk *et al.*, 1995). Cultures of 5 L of a kanamycin (50 µg/mL) and ampicillin (50 µg/mL) resistant colony were grown at 37 °C and induced by 100 µM IPTG in the exponential phase. Bacteria were harvested by centrifugation, resuspended in buffer A (30 mM Tris-HCl, 1 mM EDTA, 200 mM NaCl) containing 20 mM DTT and lysed by sonication. The soluble and insoluble fractions were separated by centrifugation. For the pMsrA WT, the recombinant protein was in the soluble fraction and precipitated between 0 and 50% of ammonium sulfate. All the other recombinant proteins were produced essentially as inclusion bodies with only a small soluble part when cultures were grown at 30°C without induction. When needed, the insoluble fraction was resuspended in buffer A in the presence of 20 mM DTT and 8 M urea and then dialyzed against 1 L of buffer A containing 500 mM urea for at least 5 hours at 5°C (all subsequent steps were realized at that temperature). The extract was centrifuged and the soluble fraction dialyzed against 1 L of buffer A for 5 hours and centrifuged. The resulting soluble fraction was purified by exclusion size chromatography onto an ACA 44 column equilibrated in buffer A. The fractions of interest were pooled, dialyzed to remove salts, and separated by DEAE Sephacel chromatography. The recombinant proteins were eluted around 100 mM NaCl using

a linear gradient from 0 to 400 mM NaCl. The purified fractions were dialyzed to remove salts, adjusted to 1.6 M NaCl and applied to a Phenyl Sepharose column equilibrated with buffer B (30 mM Tris-HCl, 1 mM EDTA, 1.6 M NaCl). The recombinant proteins were eluted by a decreasing gradient between 1.6 and 0 M NaCl, dialyzed and concentrated. The purity of the proteins was assessed using 15% SDS-PAGE. The protein concentration was estimated spectrophotometrically using a molar extinction coefficient of  $25700 \text{ M}^{-1} \text{ cm}^{-1}$  for cMsrA and pMsrA. The proteins were stored at  $-30^\circ\text{C}$  in buffer A either in the presence of 14 mM  $\beta$ -mercaptoethanol or 25 to 30 mM DTT.

### ***Crystallization, X-ray data collection, structure determination and refinement***

Crystallisation of pMsrA was achieved by hanging-drop vapour-diffusion method in Linbro multiwell tissue-culture plates, at 277 K. The purified enzyme was concentrated to 40 mg/ml in a solution containing 30 mM Tris-HCl, pH 7.0, 14 mM  $\beta$ -mercaptoethanol, and 1 mM EDTA. The crystals were grown from 4  $\mu\text{l}$  droplets composed of equal volumes of the protein solution and of the precipitant solution (10% W/V polyethyleneglycol 6000, 2 M NaCl), and equilibrated against 700  $\mu\text{L}$  reservoirs. Long needles (1 mm) with a thin triangular cross-section (0.03 mm) appeared after 6 weeks. Crystals were briefly soaked in a cryoprotectant solution (10 % V/V methylpentanediol mixed with the precipitant solution) and flash-frozen by fast immersion in nitrogen gas stream at 100 K, maintained during the X-Ray diffraction experiments performed on beamline BM30A (FIP) at the ESRF.

Crystals belong to space group  $P3_1$  with unit cell parameters  $a = b = 68.6 \text{ \AA}$ ,  $c = 40.7 \text{ \AA}$  and contain one monomer per asymmetric unit. Using a wavelength of  $1.009 \text{ \AA}$ , one native data set was collected up to  $1.7 \text{ \AA}$  resolution, and processed using DENZO (Otwinowski and Minor, 1997). Further details are given in Table IV.

The structure was solved using the molecular replacement method implemented in Molrep (Vagin and Teplyakov, 1997) of the CCP4 program suite. The initial model used in Molrep consisted of the core ( $^{41}\text{Gly-Pro}^{194}$ ) of the *E. coli* MsrA structure (PDB entry: 1FF3). The molecular replacement solution was submitted to the Molrep mode and then to the warpNtrace mode of the Arp/wArp5.1 automatic model building and refinement program (Perrakis *et al.*, 1999). It produced a model that contained 4 polypeptide chains representing 164 amino acids, with R and free-R factors of 20.6 and 25.8 %, respectively. Manual corrections (in particular, building of the missing residues) and automatic CNS refinement (Brünger *et al.*, 1998) of the model were then performed in an iterative procedure, until the

model fulfilled satisfactory criteria. The final structure corresponds to 183 amino acids among 204 (residues <sup>22</sup>Pro-Gly<sup>204</sup>), 183 water molecules, with R = 19.5 %, R<sub>free</sub> = 20.1%. Further details are given in Table V.

### ***Thiol content titration***

250 µg of the recombinant proteins were treated either with 50 mM DTT or 50 mM L-MetSO during one hour at room temperature. The proteins were then precipitated on ice by addition of one volume of 20% trichloroacetic acid (TCA) for 30 minutes. The proteins were pelleted by centrifugation and washed twice with 2% TCA. The pellets were resuspended in 30 mM Tris-HCl pH 8.0, 1 mM EDTA and 2% SDS. The concentration of the proteins were determined spectrophotometrically at this stage and then DTNB was added to a final concentration of 100 µM and the absorbance was read at 412 nm one hour later. The thiol content was determined using a molar extinction coefficient of 13600 M<sup>-1</sup> cm<sup>-1</sup> for TNB<sup>-</sup>.

### ***Enzymatic assays***

#### ***HPLC detection and measurement of MsrA activity in the presence of DTT***

The reaction mixture of 1 mL contained 10 mM DTT or various Trx amounts, 5 µM pMsrA and 100 mM L-MetSO in buffer C. After 1, 2, 3 or 4 minutes, 2.5 µL of trifluoroacetic acid (TFA) were added to aliquots of 250 µL and the methionine formed was measured by HPLC on Sephasil C18 column (Boschi-Muller *et al.*, 2000).

#### ***Thioredoxin dependent methionine sulfoxide reductase activity***

The activity of cMsrA and pMsrA in the presence of Trx was measured by following the NADPH oxidation at 340 nm in the presence of the Trx or Grx system. A 500 µL cuvette is constituted of 30 mM Tris-HCl pH 8.0, 1 mM EDTA, 200 µM NADPH, 2 µM *Arabidopsis thaliana* NADPH thioredoxin reductase, various concentrations of cytosolic thioredoxins and 10 mM L-MetSO. After one minute of incubation, MsrA was added to the reaction mixture. Trx h1 and h3 and Grx from poplar were purified as described previously (Behm and Jacquot, 1999, Gelhaye *et al.*, in press, Rouhier *et al.*, 2002). The reaction was carried out at 30°C with a Cary 50 spectrophotometer. The catalytic parameters for Trx or MetSO were determined at saturating concentrations of the other enzyme substrate.



### *Stoichiometry of methionine formation in the absence of reductants*

The different proteins were reduced by 50 mM DTT and dialyzed twice against 1 L of 30 mM Tris-HCl pH 8.0, 1 mM EDTA (buffer C). A typical 200  $\mu$ L reaction mixture containing 100 to 400  $\mu$ M proteins and 100 mM L MetSO in buffer C was incubated at room temperature for 10 minutes. 100  $\mu$ L were then injected onto a Sephasil C18 column to quantify the concentration of Met formed (Boschi-Muller *et al.*, 2000).

### *NMR determination of activity*

The reductase activity was determined by monitoring the reduction of MetSO to Met by MsrA using DTT as reducing agent. The assay conditions were 100 mM phosphate buffer, 50 mM DTT, 20 mM L-MetR,S-SO at pH 8.5 in 90%/10% H<sub>2</sub>O/D<sub>2</sub>O. L-alanine (10 mM) was used for internal concentration calibration. The enzyme was added directly in the NMR cell and careful homogeneization of the sample was performed just before recording. NMR spectra were recorded with 8 scans at 27 °C every 79 seconds on Varian Inova 400 MHz spectrometer equipped with a triple-resonance (1H, 13C, 15N) probe including shielded z-gradients. Data were processed using FELIX 97 (Accelrys).

## References

Behm, M. and Jacquot, J.P. (2000) Isolation and characterization of thioredoxin h from poplar xylem. *Plant Physiol. Biochem.*, **38**, 363-369.

Beraud, S., Bersch, B., Brutscher, B., Gans, P., Barras, F. and Blackledge, M. (2002) Direct structure determination using residual dipolar couplings: reaction-site conformation of methionine sulfoxide reductase in solution. *J. Am. Chem. Soc.*, **124**, 13709-13715.

Boschi-Muller, S., Azza, S., Sanglier-Cianferani, S., Talfournier, F., Van Dorsselaar, A. and Branlant, G. (2000) A sulfenic acid enzyme intermediate is involved in the catalytic mechanism of peptide methionine sulfoxide reductase from *Escherichia coli*. *J. Biol. Chem.*, **275**, 35908-35913.

Boschi-Muller, S., Azza, S. and Branlant, G. (2000) *E. coli* methionine sulfoxide reductase with a truncated N terminus or C terminus, or both, retains the ability to reduce methionine sulfoxide. *Protein Sci.*, **10**, 2272-2279.

Brot, N., Weissbach, L., Werth, J. and Weissbach, H. (1981) Enzymatic reduction of protein-bound methionine sulfoxide. *Proc. Natl. Acad. Sci. USA*, **78**, 2155-2158.

Brot, N. and Weissbach, H. (2000) Peptide methionine sulfoxide reductase: biochemistry and physiological role. *Biopolymers*, **55**, 288-296.

Brünger, A. T., Adams, P. D., Clore, G. M., DeLano, W. L., Gros, P., Grosse-Kunstleve, R. W., Jiang, J. S., Kuszewski, J., Nilges, M., Pannu, N. S., Read, R. J., Rice, L. M., Simonson, T. and Warren, G. L. (1998) Crystallography & NMR system: a new software suite for macromolecular structure determination. *Acta Crystallogr. D Biol. Crystallogr.*, **54**, 905-921.

Ciorba, M.A., Heinemann, S.H., Weissbach, H., Brot, N. and Hoshi, T. (1997) Modulation of potassium channel function by methionine oxidation and reduction. *Proc. Natl. Acad. Sci. USA*, **94**, 9932-9937.

Cooper,C.E., Patel,R.P., Brookes,P.S. and Darley-Usmar,V.M. (2002) Nanotransducers in cellular redox signaling: modification of thiols by reactive oxygen and nitrogen species. *Trends Biochem. Sci.*, **27**, 489-492.

Dhandayuthapani,S., Blaylock,M.W., Bebear,C.M., Rasmussen,W.G. and Baseman,J.B. (2001) Peptide methionine sulfoxide reductase (MsrA) is a virulence determinant in *Mycoplasma genitalium*. *J. Bacteriol.*, **183**, 5645-5650.

Etienne,F., Spector,D., Brot,N. and Weissbach, H. (2003) A methionine sulfoxide reductase in *Escherichia coli* that reduces the R enantiomer of methionine sulfoxide. *Biochem. Biophys. Res. Commun.*, **300**, 378-382.

Gelhaye,E., Rouhier,N., Vlamis-Gardikas,A., Girardet,J.M., Sautière,P.E., Sauzet,M., Martin,F., Jacquot,J.P. Identification and characterization of a third thioredoxin h in poplar. *Plant Physiol. Biochem.*, *In press*

Gonzalez-Porque,P., Baldesten,A. and Reichard, P. (1970) The involvement of the thioredoxin system in the reduction of methionine sulfoxide and sulfate. *J. Biol. Chem.*, **245**, 2371-2374.

Grimaud,R., Ezraty,B., Mitchell,J.K., Lafitte,D., Briand,C., Derrick,P.J. and Barras,F. (2001) Repair of oxidized proteins. Identification of a new methionine sulfoxide reductase. *J. Biol. Chem.*, **276**, 48915-48920.

Gustavsson,N., Kokke,B.P., Harndahl,U., Silow,M., Bechtold,U., Poghosyan,Z., Murphy,D., Boelens,W.C. and Sundby,C. (2002) A peptide methionine sulfoxide reductase highly expressed in photosynthetic tissue in *Arabidopsis thaliana* can protect the chaperone-like activity of a chloroplast-localized small heat shock protein. *Plant J.*, **29**, 545-553.

Hassouni,M.E., Chambost,J.P., Expert,D., Van Gijsegem,F. and Barras,F. (1999) The minimal gene set member msrA, encoding peptide methionine sulfoxide reductase, is a virulence determinant of the plant pathogen *Erwinia chrysanthemi*. *Proc. Natl. Acad. Sci. USA*, **96**, 887-892.

Jacquot,J.P., Stein,M., Suzuki,A., Liottet,S., Sandoz,G. and Miginiac-Maslow,M. (1997) Residue Glu-91 of *Chlamydomonas reinhardtii* ferredoxin is essential for electron transfer to ferredoxin-thioredoxin reductase. *FEBS Lett.*, **400**, 293-296.

Jung,S., Hansel,A., Kasperczyk,H., Hoshi,T. and Heinemann,S.H. (2002) Activity, tissue distribution and site-directed mutagenesis of a human peptide methionine sulfoxide reductase of type B: hCBS1. *FEBS Lett.*, **527**, 91-94.

Kohler,A., Delaruelle, C., Martin, D., Encelot, N. and Martin, F. (2003) The poplar root transcriptome: analysis of 7000 expressed sequence tags. *FEBS Lett.*, *In press*

Kryukov,G.V., Kumar,R.A., Koc,A., Sun,Z. and Gladyshev,V.N. (2002) Selenoprotein R is a zinc-containing stereo-specific methionine sulfoxide reductase. *Proc. Natl. Acad. Sci. USA*, **99**, 4245-4250.

Kumar,R.A., Koc,A., Cerny,R.L. and Gladyshev,V.N. (2002) Reaction mechanism, evolutionary analysis, and role of zinc in *Drosophila* methionine-R-sulfoxide reductase. *J. Biol. Chem.*, **277**, 37527-37535.

Larsson,S., Bjorkbacka,H., Forsman,C., Samuelsson,G. and Olsson,O. (1997) Molecular cloning and biochemical characterization of carbonic anhydrase from *Populus tremula x tremuloides*. *Plant Mol. Biol.*, **34**, 583-592.

Levine,R.L., Moskovitz,J. and Stadtman,E.R. (2000) Oxidation of methionine in proteins: roles in antioxidant defense and cellular regulation. *IUBMB Life*, **50**, 301-307.

Lowther,W.T., Brot,N., Weissbach,H. and Matthews, B.W. (2000) Structure and mechanism of peptide methionine sulfoxide reductase, an "anti-oxidation" enzyme. *Biochemistry*, **39**, 13307-13312.

Lowther,W.T., Weissbach,H., Etienne,F., Brot,N. and Matthews,B.W. (2002) The mirrored methionine sulfoxide reductases of *Neisseria gonorrhoeae* pilB. *Nat. Struct. Biol.*, **9**, 348-352.

Moskovitz,J., Berlett,B.S., Poston,J.M. and Stadtman,E.R. (1997) The yeast peptide-methionine sulfoxide reductase functions as an antioxidant *in vivo*. *Proc. Natl. Acad. Sci. USA*, **94**, 9585-9589.

Moskovitz,J., Flescher,E., Berlett,B.S., Azare,J., Poston,J.M. and Stadtman,E.R. (1998) Overexpression of peptide-methionine sulfoxide reductase in *Saccharomyces cerevisiae* and human T cells provides them with high resistance to oxidative stress. *Proc Natl Acad Sci USA*, **95**, 14071-14075.

Moskovitz,J., Poston,J.M., Berlett,B.S., Nosworthy,N.J., Szczepanowski,R. and Stadtman,E.R. (2000) Identification and characterization of a putative active site for peptide methionine sulfoxide reductase (MsrA) and its substrate stereospecificity. *J. Biol. Chem.*, **275**, 14167-14172.

Novoselov,S.V., Rao,M., Onoshko,N.V., Zhi,H., Kryukov,G.V., Xiang,Y., Weeks,D.P., Hatfield,D.L. and Gladyshev,V.N. (2002) Selenoproteins and selenocysteine insertion system in the model plant cell system, *Chlamydomonas reinhardtii*. *EMBO J.*, **21**, 3681-3693.

Olry,A., Boschi-Muller,S., Marraud,M., Sanglier-Cianferani,S., Van Dorsselaar,A. and Branlant,G. (2002) Characterization of the methionine sulfoxide reductase activities of PILB, a probable virulence factor from *Neisseria meningitidis*. *J. Biol. Chem.*, **277**, 12016-12022.

Otwinowski,Z., and Minor,W. (1997) Processing of X-ray diffraction data collected in oscillation mode. *Methods Enzymol.*, **276**, 307-326.

Perrakis,A., Morris,J.R. and Lamzin,V.S. (1999) Automated protein model building combined with iterative structure refinement. *Nat. Struct. Biol.*, **6**, 458-463.

Rouhier,N., Gelhaye,E., Sautiere,P.E. and Jacquot,J.P. (2002) Enhancement of poplar glutaredoxin expression by optimization of the cDNA sequence. *Protein Expr. Purif.*, **24**, 234-241.

Russel,M. and Model,P. (1986) The role of thioredoxin in filamentous phage assembly. Construction, isolation, and characterization of mutant thioredoxins. *J. Biol. Chem.*, **261**, 14997-15005.

Sadanandom,A., Poghosyan,Z., Fairbairn,D.J. Murphy,D.J. (2000) Differential regulation of plastidial and cytosolic isoforms of peptide methionine sulfoxide reductase in *Arabidopsis*. *Plant Physiol.*, **123**, 255-264.

Saint-John,G., Brot,N., Ruan,J., Erdjument-Bromage,H., Tempst,P., Weissbach,H. and Nathan,C. (2001) Peptide methionine sulfoxide reductase from *Escherichia coli* and *Mycobacterium tuberculosis* protects bacteria against oxidative damage from reactive nitrogen intermediates. *Proc. Natl. Acad. Sci. USA*, **98**, 9901-9906.

Schenk,P.M., Baumann,S., Mattes,R. and Steinbiss,H.H. (1995) Improved high-level expression system for eukaryotic genes in *Escherichia coli* using T7 RNA polymerase and rare Arg tRNA's. *Biotechniques*, **19**, 196-200.

Sharov,V.S., Ferrington,D.A., Squier,T.C. and Schoneich,C. (1999) Diastereoselective reduction of protein-bound methionine sulfoxide by methionine sulfoxide reductase. *FEBS Lett.*, **455**, 247-250.

Spector,D., Etienne,F., Brot,N. and Weissbach,H. (2003) New membrane-associated and soluble peptide methionine sulfoxide reductases in *Escherichia coli*. *Biochem. Biophys. Res. Commun.*, **302**, 284-289.

Stadtman, E.R. (1993) Oxidation of free amino acids and amino acid residues in proteins by radiolysis and by metal-catalyzed reactions. *Annu. Rev. Biochem.*, **62**, 797-821.

Stadtman,E.R., Moskovitz,J., Berlett,B.S. and Levine,R.L. (2002) Cyclic oxidation and reduction of protein methionine residues is an important antioxidant mechanism. *Mol. Cell. Biochem.*, **234**, 3-9.

Stewart,E.J., Aslund,F. and Beckwith,J. (1998) Disulfide bond formation in the *Escherichia coli* cytoplasm: an in vivo role reversal for the thioredoxins. *EMBO J.*, **17**, 5543-5550.

Storz,G. and Imlay,J.A. (1999) Oxidative stress. *Curr. Opin. Microbiol.*, **2**, 188-194.

Tete-Favier,F., Cobessi,D., Boschi-Muller,S., Azza,S., Branlant,G. and Aubry,A. (2000) Crystal structure of the *Escherichia coli* peptide methionine sulphoxide reductase at 1.9 Å resolution. *Structure Fold Des.*, **8**, 1167-1178.

Vagin,A., and Teplyakov,A. (1997) MOLREP: an automated program for molecular replacement., *J. Appl. Cryst.*, **30**, 1022-1025.

Wizemann,T.M., Moskovitz,J., Pearce,B.J., Cundell,D., Arvidson,C.G., So,M., Weissbach,H., Brot,N. and Masure,H.R. (1996) Peptide methionine sulfoxide reductase contributes to the maintenance of adhesins in three major pathogens. *Proc. Natl. Acad. Sci. USA.*, **93**, 7985-7990.

Yao,Y., Yin,D., Jas,G.S., Kuczer,K., Williams,T.D., Schoneich,C. and Squier,T.C. (1996) Oxidative modification of a carboxyl-terminal vicinal methionine in calmodulin by hydrogen peroxide inhibits calmodulin-dependent activation of the plasma membrane Ca-ATPase. *Biochemistry*, **35**, 2767-2787.

## Figure legends

**Fig. 1.** Amino acid comparison of the two poplar MsrA with known MsrA sequences. The sequences were compared using ClustalW. The accession numbers (GenBank or MATDB) are as follow : *Populus tremula x tremuloides* pMsrA (Pt pMsrA) : **xxxxxx**, *Arabidopsis thaliana* cMsrA (At cMsrA) : At5g61640, *Arabidopsis thaliana* pMsrA (At pMsrA) : At4g25130, *Brassica napus* pMsrA (Bn pMsrA) : P54151, *Populus tremula x tremuloides* cMsrA (Pt cMsrA) : **xxxxxx**, *Escherichia coli* MsrA (Ec MsrA) : NP\_418640, *Bos taurus* MsrA (Bs MsrA) : P54149. The stars represent strict amino acid identities.

**Fig. 2.** MetSO reductive activity of wild-type and mutant cytosolic (cMsrA) and plastidial (pMsrA) poplar sulfoxide methionine reductases. A) MetSO concentration evolution as a function of time; cMsrA (full circles), pMsrA (full squares), C31S mutant of pMsrA (open circles), C46S mutant of cMsrA (open squares). B) Met concentration evolution as a function of time; cMsrA (full circles), pMsrA (full squares), C31S mutant of cMsrA (open squares), C46S mutant of pMsrA (open circles). Reactions were recorded at 25 °C in the presence of 100 mM phosphate buffer with 50 mM DTT, 20 mM (L)Met(D,L)SO at pH 8.5. The enzyme concentrations were for cMsrA, pMsrA, C31S and C46S : 4.7 M, 6.1 M, 4.7 M and 4.9 M respectively. MetSO and Met concentrations were determined from the methyl peak intensity of the MetSO at 2.65 ppm and the Met at 2.15 ppm.

**Fig. 3.** C $\alpha$ traces of the pMsrA (blue) and *E. coli* MsrA (red). The five cysteinyl residues of the poplar enzyme are shown in balls and sticks.

**Fig. 4.** Schematic drawing of the pMsrA structure. The  $\beta$ -strands are represented as arrows and the  $\alpha$ -helices as springs. The trace of residues <sup>167</sup>Lys-Gly<sup>204</sup> is shown in red. The five cysteinyl residues are shown in balls and sticks.

**Fig. 5.** 3Fo-2Fc electron density maps contoured at 1.2 $\sigma$  in the Cys46 (a), Cys81 (b), Cys100 (c), Cys196 (d) and Cys202 (e) regions. Cys46, Cys196 and Cys202 are bonded to a  $\beta$ -mercaptoethanol molecule via a disulfide bridge. Cys81 is observed as a sulfenic acid, while Cys100 is in reduced form.





	$K_{\text{Trx h1}}$ ( $\mu\text{M}$ )	$K_{\text{Trx h3}}$ ( $\mu\text{M}$ )	$K_{\text{MetSO}}$ ( $\mu\text{M}$ )	kcat ( $\text{s}^{-1}$ )	kcat/ $K_{\text{MetSO}}$ ( $\times 10^3 \text{ M}^{-1} \text{ s}^{-1}$ )	$V_{\text{max}}$ ( $\mu\text{moles NADPH ox/min}/\mu\text{moles}$ ) ( $\mu\text{moles NADPH ox/min}/\text{mg protein}$ )
cMsrA	$15.2 \pm 2.9$	$17.5 \pm 3.2$	$383 \pm 101$	1.2	3.13	73 (1.55)
pMsrA	$17.9 \pm 8$	n.d.	$239 \pm 33$	0.29	1.2	17.22 (0.40)

**Table I.** Catalytic parameters of pMsrA and cMsrA. These parameters were determined by following the NADPH oxidation in the presence of 10 mM L-Met-R,S-SO, poplar cytosolic Trx h1 and h3 as electron donors and 0.5  $\mu\text{M}$  cMsrA or 3  $\mu\text{M}$  pMsrA. The  $K_m$  for Trx h1, Trx h3 and MetSO were measured at saturating concentration of the other substrate. n.d. : not determined.

	Stoichiometry
cMsrA wt	1.72 (2)
cMsrA C31S	0 (0)
cMsrA C66S	1.4 (2)
cMsrA C85S	1.41 (2)
cMsrA C182S	1.16 (1)
cMsrA C188S	1.68 (1)
pMsrA wt	1.8 (2)

**Table II.** Stoichiometry of Met formed in the absence of reductant. The results are expressed in mol Met formed /mol enzyme. In parenthesis, the theoretical ratio based on the catalytic mechanism of *E. coli*.

	Number of free thiols without L-Met-R,S-SO	Number of free thiols with L-Met-R,S-SO	Decrease in free thiols
cMsrA wt	4.48 (5)	1.11 (2)	3.37 (3)
cMsrA C31S	3.9 (4)	3.7 (4)	0.2 (0)
cMsrA C66S	4.09 (4)	0.7 (1)	3.39 (3)
cMsrA C85S	3.9 (4)	0.4 (1)	3.5 (3)
cMsrA C182S	3.4 (4)	2.37 (3)	1.03 (1)
cMsrA C188S	3.85 (4)	1.5 (2)	2.35 (2)
pMsrA wt	4.25 (5)	1.33 (2)	2.92 (3)
pMsrA C46S	4.3 (4)	4.0 (4)	0.3 (0)
pMsrA C196S	3.5 (4)	2.4 (3)	1.1 (1)
pMsrA C202S	4.1 (4)	1.8 (2)	2.3 (2)

**Table III.** Thiol content of WT and mutants MsrA after treatment or not with L-Met-R,S-SO. In parenthesis, the theoretical content of thiols based on the catalytic mechanism of *E. coli* MsrA.

Wavelength	1.009 Å (ESRF, BM30)
Temperature	100 K
Resolution	25.0-1.7 (1.74-1.70) Å
Number of measured reflections	114471
Number of independent reflections	23121
Completeness	98.2 (83.4) %
R <sub>sym</sub>	4.8 (21.9) %
$\langle I \rangle / \langle \sigma_I \rangle$	8.6 (2.5)

**Table IV.** Statistics of X-ray diffraction data collection for the pMsrA crystals. Values in parenthesis refer to data in the highest resolution shell.

Resolution range <sup>†</sup> (Å)	25.0 – 1.7 (1.76 – 1.70)
No. of reflections used for R calculation <sup>†</sup>	21710 (1812)
No. of reflections used for R <sub>free</sub> calculation <sup>†</sup>	1103 (84)
Data cutoff F/ (F)	0.0
R value <sup>†</sup> (%)	19.5 (23.4)
R <sub>free</sub> value <sup>†</sup> (%)	20.1 (23.4)
No. of non-hydrogen protein atoms	1478
No. of water molecules	183
Mean B-factor, protein main chain atoms (Å <sup>2</sup> )	23.6
Mean B-factor, protein side chain atoms (Å <sup>2</sup> )	25.2
Mean B-factor, solvent atoms (Å <sup>2</sup> )	28.5
B-factor from the Wilson plot (Å <sup>2</sup> )	27.6
Ramachandran plot:	
residues in most favoured regions (%)	92.7
residues in additionally allowed regions (%)	7.3
residues in generously allowed regions (%)	0
residues in disallowed regions (%)	0
Rms deviation from ideal geometry	
bond length (Å)	0.006
bond angle (°)	1.31
Rms deviation for isotropic thermal factor restraints	
(Å <sup>2</sup> ) :	0.98
Main-chain bond	1.53
Main-chain angle	1.82
Side-chain bond	2.65
Side-chain angle	

**Table V.** Refinement and model statistics. <sup>†</sup>Values indicated between parenthesis correspond to statistics in the outer resolution shell.

	Cys46	Cys81	Cys100	Cys196	Cys202
Cys46		10.0 Å	22.1 Å	18.0 Å	7.2 Å
Cys81			22.1 Å	27.5 Å	16.0 Å
Cys100				16.4 Å	22.8 Å
Cys196					15.8 Å
Cys202					

**Table VI.** Distances measured between the S $\gamma$  atoms of the five cysteine residues present in the pMsrA structure.

cMsrA forward	5' <u>CCCCCCATGGCA</u> ACCAGCACCACCAAT 3'
cMsrA reverse	5' CCCC <u>GGATCCTT</u> AACCATAGCATCTAATAGG 3'
cMsrA C31S forward	5' GCTCAATTCGGAGCTGGA <b>AG</b> TTTCTGGGGGGTT 3'
cMsrA C31S reverse	5' AACCCCCCAGAAACTTCCAGCTCCGAATTGAGC 3'
cMsrA C66S forward	5' ACTTACAAGCTGGTATCCACCAACACCACCAAC 3'
cMsrA C66S reverse	5' GTTGGTGGTGTGGTGGATAACCAGCTTGTAAGT 3'
cMsrA C85S forward	5' TTTGACCCGGAAGTTTCCCCATATACCAACCTC 3'
cMsrA C85S reverse	5' GAGGTTGGTATATGGGGAAACTTCCGGGTCAAA 3'
cMsrA C182S forward	5' TCTGCTGAAAAAGGTTCCAATGACCCTATTAGA 3'
cMsrA C182S reverse	5' TCTAATAGGGTCATTGGAACCTTTTTTCAGCAGA 3'
cMsrA C188S reverse	5' CCCC <u>GGATCCTT</u> AACCATAGCTTCTAATAGGGTCATTG CA 3'
pMsrA forward	5' <u>CCCCCCATGG</u> <b>CT</b> AACATCCTTAGCAAAGTAGGC 3'
pMsrA reverse	5' CCCC <u>GGATCCTT</u> AGCCATAGCATCGGATTGGATC 3'
pMsrA C46S forward	5' TTTGGAGCTGGTTCTTTTTGGGGTGT 3'
pMsrA C46S reverse	5' AACACCCCCAAAA <b>GA</b> ACCAGCTCCAAA 3'
pMsrA C196S forward	5' GCTGAGAAAGGATCCAATGATCCAATC 3'
pMsrA C196S reverse	5' GATTGGATCATTGGATCCTTTCTCAGC 3'
pMsrA C202S reverse	5' CCCC <u>GGATCCTT</u> AGCCATAGGATCGGATTGG 3'

**Table VII.** Cloning and mutagenic oligonucleotides. The *Nco*I and *Bam*HI restriction sites are underlined and the mutagenic bases in bold characters. The primer pMsrA forward allows us to integrate an alanine (codon GCT in bold) downstream the initial methionine.



Pt pMsrA	MLQTLSTHLSSTSTSTTTPLLLLLSKPFLSPSAKSQLSHSHKPFNFPRTLKPISYKPMN-I	59
At cMsrA	-----MN-I	3
At pMsrA	MQVLVVSPLIAAASLSKPLNLSKAALSFS---RAKPICPFPPQTSRRPISVYKSPMNNL	57
Bn pMsrA	MLSIVASPPVISAVLSKPLQSLAKAALSLSK--RAKPTSPFPKTAR-SISVYKSPMNNL	57
Pt cMsrA	-----	
Bt MsrA	-----MLSVTRRALQLFHSLFPIPRM---G--DSAAKIV	29
Ec MsrA	-----MSLF-----D-KKHLV	10
Pt pMsrA	LSKLGFGRSPDPSTMDPT----IPQGPDDDLPAQGFQFAQFGAGCFWGVELAFQRVPGV	115
At cMsrA	LNRLGLGSSGQ--TNMDPS---PIAQGNDDTPAPGNQFAQFGAGCFWGVELAFQRVPGV	58
At pMsrA	FNRLGFGSRPQ--AQADPS-SAAIAQGPDDVPSGQFAQFGAGCFWGVELAYQRVPGV	114
Bn pMsrA	FTRLGFGSRP----QPDPAASSAIAQGPDDVPSGQFAQFGAGCFWGAELAYQRVPGV	113
Pt cMsrA	---MATSTTNP---ALDPD---LGQ-PDN--P--NHEFAQFGAGCFWGVELAFQRLHGV	45
Bt MsrA	SPQEALPGRKE---PLVVAAKHHVNGNRTVEPFPEGTQMAVFGMCFWGAERKFWTLKGV	86
Ec MsrA	SPADALPGRNT---PMPVATLHAVNG-HSMTNVPDGMEIAIFAMGCFWGVVERLFWQLPGV	66
	* * * * * * * * *	
Pt pMsrA	TKTEVGYTQGLLHNPTYEDVCTGTTNHNEVVRVQYDPKECSFDTLIDVLWARHDP TTLNR	175
At cMsrA	TQTEAGYTQGTVDNPSYGDVCSGTTGHSEVVRVQYDLNDCTYESLLDLFWSRHDPTTLNR	118
At pMsrA	TKTEVGYSHGIVHNPSYEDVCTGTTGHNEVVRVQYDPKECSFESLLDVFWNRHDPTTLNR	174
Bn pMsrA	TKTEVGYSHGIVDNPTYEDVCSSETTGHNEIVRVQYDPKEVVSFESLLDVFWKRHDPTTLNR	173
Pt cMsrA	VKTEVGYSQGNVPDPTYKLVCTKTTNHVEVVRVQFDPEVCPYTNLLSLFWSRHDPTTLNR	105
Bt MsrA	YSTQVGFAGGYTPNPTYKEVCSGKTGHAEVVRVVFQPEHISFEELLKVFWENHDPTQGMR	146
Ec MsrA	YSTAAGYTGGYTPNPTYREVCSGDTGHAEAVRIVYDPSVISYEQLLQVFWENHDP AQGMR	126
	* * * * * * * * *	
Pt pMsrA	QGNDVGTQYRSGIYYTPEQEKAAKESLERQQ----K-LLNRKIVTEILPAKKFYRAEEY	230
At cMsrA	QGNDVGTQYRSGIYFYTPEQEKLARESLERHQ----Q-QMERKIMTEILPAKKFYRAEEH	173
At pMsrA	QGGDVGTQYRSGIYYTDEQERIAREAVEKQQ----K-ILNRKIVTEILPATKFYRAENY	229
Bn pMsrA	QGNDVGTRYRSGIYFYTDEQEKLAREAMEKQQ----K-ILNRKIVTEILPATKFYRAENY	228
Pt cMsrA	QGGDVGTQYRSGIYYYNEAQAKLAQESKEAKQ----LGLTDNTVVTEILPAKRFYRAEEY	161
Bt MsrA	QGNDHGSQYRSAIYPTSAEHVGAALKSKEDYQKVLSEHGFG-LITTDIREGQTFYEAEDY	205
Ec MsrA	QGNDHGTQYRSAIYPLTPEQDAAARASLERFQAAMLAADDDRHITTEIANATPFYEAEDD	186
	** * * * * * * * * *	
Pt pMsrA	HQQYLAKGGRFGFMQSAEKGCNDPIRCYG	259
At cMsrA	HQQYLSKGGFRFGQGSTAKGCNDPIRCYG	202
At pMsrA	HQQYLAKGGRMGLRQSAEKGCNDPIRCYG	258
Bn pMsrA	HQQYLAKGGRMGLSQSAEKGCNDPIRCYG	257
Pt cMsrA	HRQYLEKGGGRSAKQSAEKGCNDPIRCYG	190
Bt MsrA	HQQYLSKDP-DGYCGLGGTGVSCPLGIKK	233
Ec MsrA	HQQYLHKNP-YGYCGIGGIGVCLPPEA--	212
	* * * * * * * *	

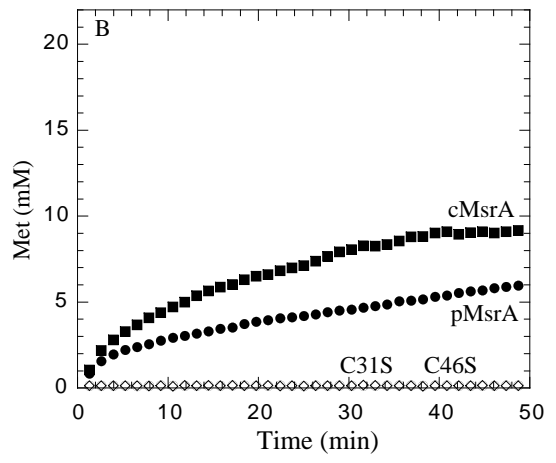
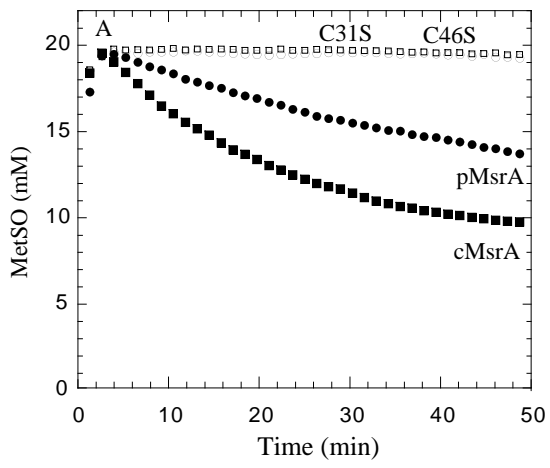

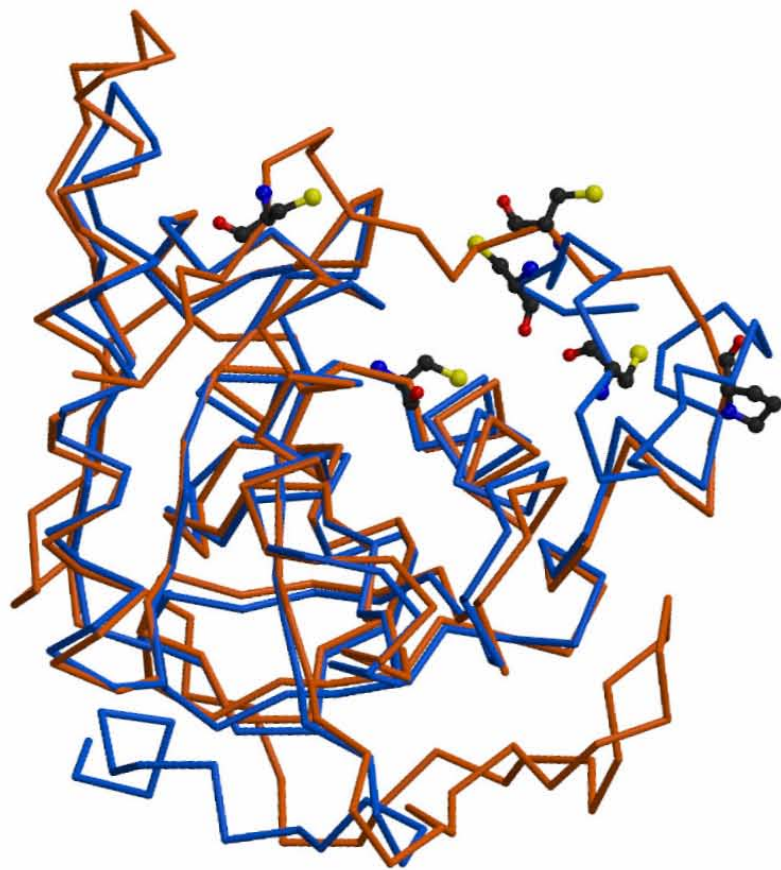

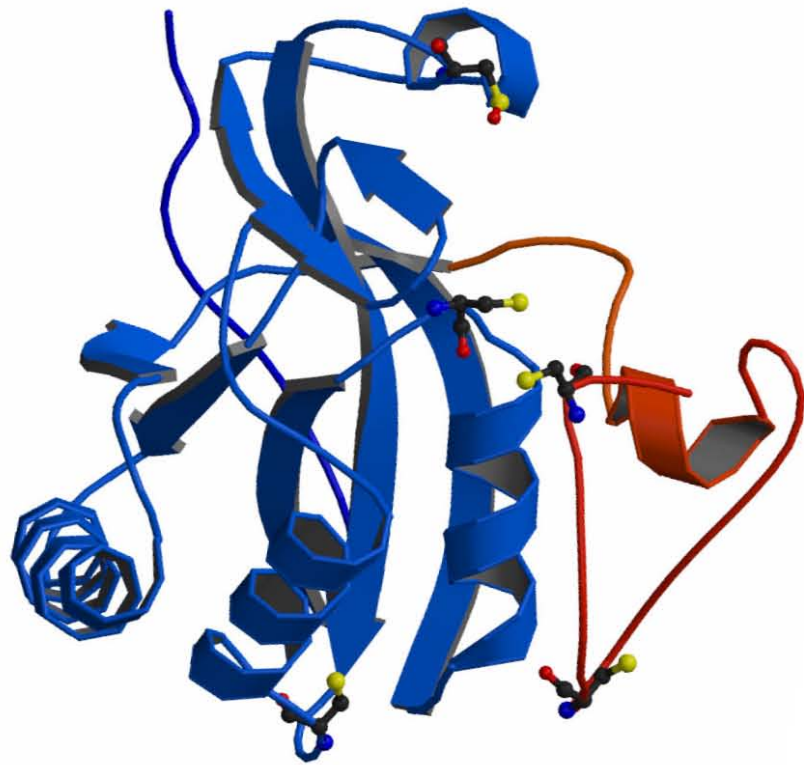

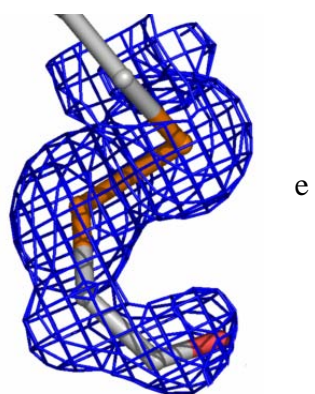
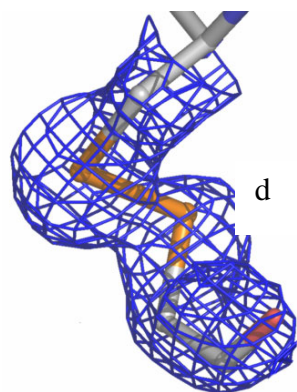
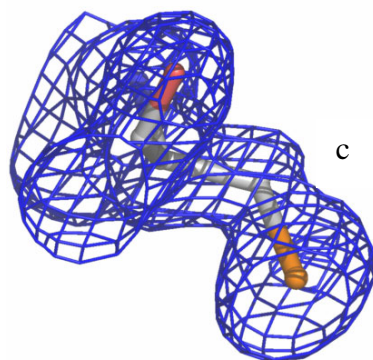
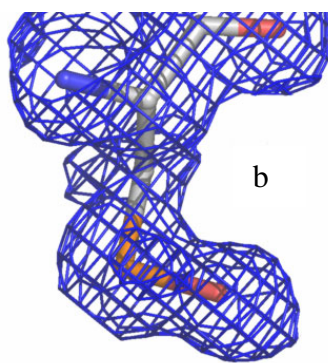
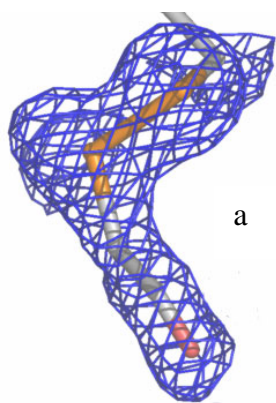

## *Discussion*

### 1. Le rôle des espèces réactives chez les plantes

Le peuplier (*Populus sp.*) constitue un organisme modèle des plantes ligneuses au même titre qu'*Arabidopsis thaliana* pour les espèces herbacées, que *Chlamydomonas reinhardtii* et *Synechocystis sp.* pour les organismes unicellulaires photosynthétiques eucaryotiques et procaryotiques. Des programmes de séquençage d'EST ou du génome ont été entrepris pour ces différentes espèces, permettant l'accès à de nombreuses séquences génomiques. L'annotation des gènes constituant le génome de ces espèces démontre que beaucoup n'ont pas encore de fonction connue. Actuellement, de nombreux outils sont développés pour identifier leur fonction et permettre de regarder à grande échelle les changements intervenant au niveau des gènes (génomique), de leur expression (transcriptomique), des protéines (protéomique) et des métabolites (métabolomique). Le peuplier est un arbre d'importance économique possédant un petit génome (550 Mb), qui peut être propagé végétativement et transformé par *Agrobacterium tumefaciens*. De plus, des programmes génétiques de cartographie de QTL sont engagés. Ainsi, de nombreux programmes de séquençages EST ont débuté en Suède essentiellement mais aussi à l'intérieur de notre unité de recherche. Près de 115 000 EST sont actuellement disponibles dans la base de donnée GenBank de NCBI (<http://www.ncbi.nlm.nih.gov>). Comme tous les organismes dépourvus de mouvements, les arbres sont soumis à des contraintes biotiques dues à divers micro-organismes (bactéries, champignons, virus) et aussi à de nombreuses contraintes abiotiques comme la sécheresse, la pollution atmosphérique, la forte salinité ou l'accumulation de métaux lourds dans les sols et les conditions changeantes de température et de lumière (Figure 19). Toutes ces réactions engendrent la formation d'espèces réactives oxygénées, nitrées ou soufrées, souvent toxiques pour les cellules. Ces molécules, radicalaires ou non, produites en grande quantité lors d'un dysfonctionnement métabolique, doivent être maintenues sous contrôle. Par ailleurs, il apparaît de plus en plus que le peroxyde d'hydrogène et l'oxyde nitrique notamment jouent un rôle essentiel dans la signalisation cellulaire. Ces espèces réactives activent ou désactivent des protéines (canaux calciques ou potassiques, calmoduline), oxydent des facteurs de transcription qui vont à leur tour modifier l'expression de nombreux autres gènes et modulent l'action de phosphatases ou de kinases et par conséquent régulent des voies de transduction (Van Camp *et al.*,

1998 ; Kovtun *et al.*, 2000 ; Pei *et al.*, 2000 ; Meinhard & Grill, 2001 ; Murata *et al.*, 2001, Zhang *et al.*, 2001a ; Neill *et al.*, 2002 ; Rodriguez *et al.*, 2002 ; Yang *et al.*, 2002a). Ainsi, l'action d' $\text{H}_2\text{O}_2$  a été démontrée dans de nombreux phénomènes, le gravitropisme des racines, la mort cellulaire programmée, le contrôle de l'ouverture et de la fermeture des stomates, la mise en place de la symbiose *Rhizobium*-Légumineuses et les phénomènes de croissance et de développement (Bestwick *et al.*, 1997 ; Joo *et al.*, 2001 ; Zhang *et al.*, 2001b ; Hérouart *et al.*, 2002 ; Ren *et al.*, 2002 ; Tiwari *et al.*, 2002). Par conséquent, tous les systèmes et enzymes impliqués dans la dégradation des ROS et RNS ont potentiellement un rôle à jouer dans ces phénomènes.

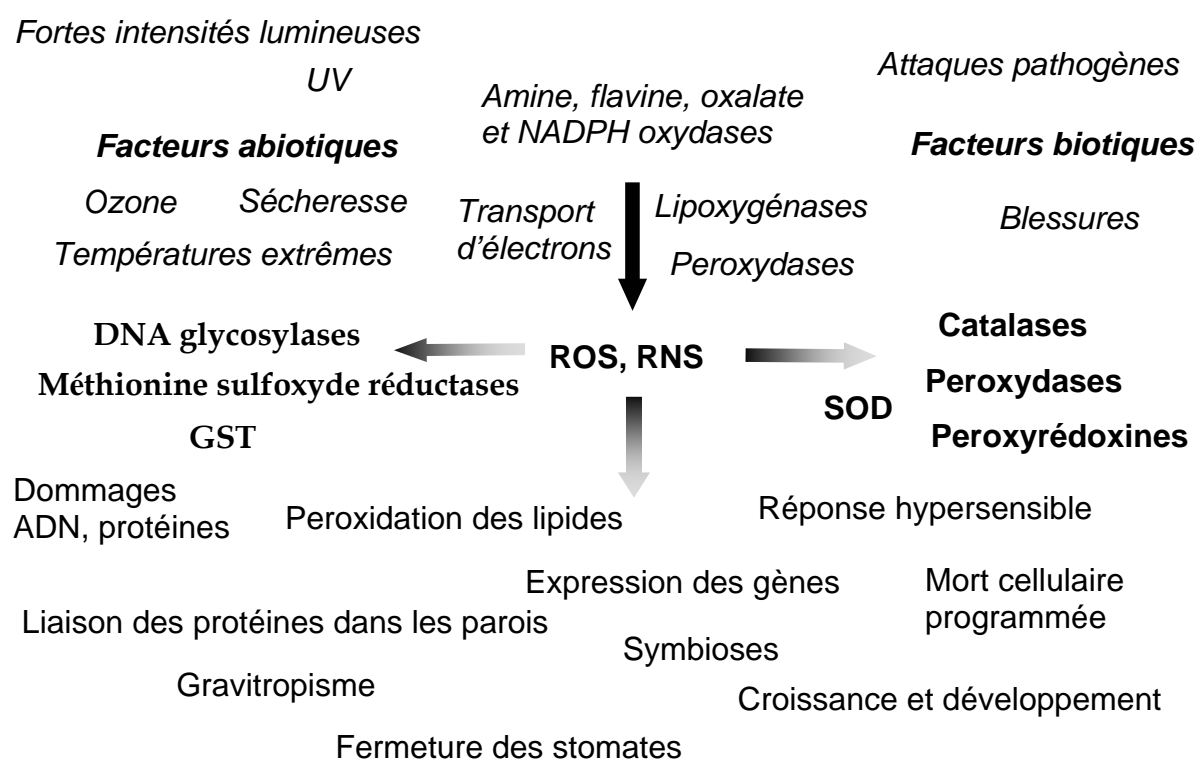

Figure 19 : **Formation et dégradation des ROS et RNS et changements induits dans la cellule.** Les ROS et RNS produits par le fonctionnement de certaines enzymes ou suite à l'apparition de stress biotiques et abiotiques provoquent de nombreux dommages pour les macromolécules, modifient l'expression des gènes et régulent certaines activités enzymatiques. Ces composés sont d'autant plus dangereux qu'ils réagissent entre eux (réactions de Fenton et de Haber-Weiss) pour former des molécules encore plus destructrices (Henle & Linn, 1997).



## 2. Intervention des Trx, Grx, Prx et MsrA dans la lutte antioxydante

Une approche de caractérisation des protéines (production de protéines recombinantes, mutagenèse dirigée, activités enzymatiques) a été employée dans ce travail pour étudier d'un point de vue fonctionnel et structural différentes isoformes de Trx et de Grx mais aussi leur interaction avec deux type d'enzymes cibles, les Prx, enzymes qui détruisent les alkyl ou phospholipide hydroperoxydes et les méthionine sulfoxyde réductases, enzymes qui réduisent les MetSO libres ou intégrées dans des peptides. Sous-jacent à ce travail, il serait intéressant de déterminer si ces multiples isoformes de Trx, Grx, Prx et MsrA sont redondantes ou spécifiques de certaines fonctions. En effet, il existe au moins 55 Trx ou Grx mono ou bicystéiniques chez *A. thaliana*, de nombreuses protéines « thioredoxin like », 8 isoformes exprimées de Prx dans différents compartiments cellulaires dont au moins 4 sont localisées dans le chloroplaste et au moins 4 isoformes de MsrA dont 3 sont vraisemblablement cytosoliques. Pour ce qui est des Prx, cette redondance est d'autant plus surprenante qu'il existe également 6 isoformes de catalases, au moins 8 de Gpx et 7 d'Apx (Frugoli *et al.*, 1996, résultats de blast dans MATDB). Cette étude visait donc à déterminer la localisation et le rôle de ces isoformes dans les différents organes de la plante et à isoler si possible des cibles spécifiques de ces isoformes et identifier leur mode d'interaction.

### 2.1 Spécificité ou redondance des systèmes réducteurs ?

Le travail préalable mené sur les Trx h et les Grx de peuplier consiste à isoler et caractériser les différentes isoformes constituant les systèmes de réduction du peuplier.

Quatre isoformes de Trx cytosoliques bicystéiniques ont ainsi été isolées chez le peuplier, popTrx h1, h3 et h4, une Trx monocystéinique (popTrx CxxS2), une Trx mitochondriale (popTrx h2) et deux Grx, une bicystéinique et une monocystéinique. Les isoformes popTrx h1 et h3 possèdent 2 sites actifs différents (WCPPC et WCGPC respectivement) mais elles ont toutes deux la capacité de réduire les Prx (Q et de type II) et les MsrA suggérant qu'il n'y a pas de spécificité *in vitro* des Trx envers ces enzymes alors que la Grx ne réduit que la Prx de type II. Néanmoins, certaines spécificités entre donneurs d'électrons et protéines cibles existent

quelquefois *in vitro*. Des études d'activité entre 7 Trx chloroplastiques d'*A. thaliana* et 3 protéines cibles (FBPase, MDH à NADP et Prx à 2 cystéines) indiquent que certaines Trx ne réduisent spécifiquement que certaines protéines cibles. Ainsi, par exemple la Trx x ne réduit que la Prx à 2 cystéines et la FBPase n'est réduite que par la Trx f (Collin *et al.*, 2003). Certains travaux ont déjà mis en évidence ce type de spécificité *in vivo*. Ainsi, la complémentation d'un double mutant pour les Trx de *S. cerevisiae* avec différentes Trx (h, m, f et x) d'*A. thaliana* a permis de montrer que des spécificités de reconnaissance existent puisque certaines Trx cytosoliques et chloroplastiques testées ne complémentent que certaines déficiences (Mouaheb *et al.*, 1998 ; Bréhelin *et al.*, 2000 ; Issakidis-Bourguet *et al.*, 2001).

La spécificité d'interaction peut être due également à une localisation commune et/ou une expression simultanée dans le temps du réducteur et de la protéine cible. Ainsi, des études d'expression menées avec une Trx h de *Zea mays*, deux Trx h de *Triticum aestivum*, 8 Trx h et 5 Trx chloroplastiques d'*A. thaliana* démontrent que les gènes ne sont effectivement exprimés que dans certains organes ou tissus ou seulement en réponse à des traitements précis (Mestres-Ortega & Meyer, 1999 ; Serrato *et al.*, 2001 ; Reichheld *et al.*, 2002 ; Santandrea *et al.*, 2002).

Ces études sur la spécificité ne concernent pas que les plantes, ainsi chez *Helicobacter pylori* et *D. melanogaster*, seule une des 2 Trx isolées est capable de réduire respectivement une AhpC ou la thiorédoxine peroxidase 1 (Baker *et al.*, 2001 ; Bauer *et al.*, 2002). Chez *E. coli*, il existe 2 Trx et 3 Grx bicystéiniques et seules certaines sont des donneurs d'électrons pour des protéines cibles telles que la ribonucléotide réductase ou la PAPS réductase (Russel *et al.*, 1990 ; Aslund *et al.*, 1994 ; Lillig *et al.*, 1999).

Lorsque j'ai débuté mon travail de recherche, pratiquement aucune information n'était disponible sur les Grx de plantes. La production de la protéine recombinante chez *E. coli*, rendue possible par des modifications de la séquence nucléotidique et par l'utilisation du plasmide pSBET a été une avancée importante. En effet, ce plasmide a permis également l'expression de protéines qui n'étaient pas produites en son absence, mais aussi l'expression plus importante de certaines protéines. Cette Grx possède une activité de réduction du DHA en ascorbate et représente donc un système alternatif aux DHAR. Cette enzyme est aussi un donneur d'électrons potentiel pour la RNR de peuplier puisqu'elle est capable de réduire celle d'*E. coli*. Toutefois, elle ne permet pas de réduction directe d'H<sub>2</sub>O<sub>2</sub>

contrairement à la Grx1 de *S. cerevisiae* et à une isoforme de Grx d'*O. sativa* (Collinson *et al.*, 2002 ; Lee *et al.*, 2002). Par contre, cette Grx participe tout de même à la détoxification des ROS en tant que donneur d'électrons pour la Prx de type II mais pas pour la Prx Q ni pour les MsrA. Cette Prx de type II constitue donc la première enzyme cible des Grx identifiée chez les plantes. L'importance des acides aminés constituant le site actif de cette Grx ( $_{26}YCPYC_{30}$ ) a notamment démontré qu'elle peut fonctionner selon un mode monothiol puisque la Cys30 n'est pas nécessaire pour la plupart des réactions catalysées par la Grx. De plus, la transformation du site actif en un site actif de Trx ( $_{26}WCPPC_{30}$ ) n'est pas suffisante pour modifier l'activité de l'une en l'autre. En effet, les interactions des Trx et des Grx avec leurs protéines cibles dépendent de plusieurs paramètres, notamment de la présence en surface de la protéine d'acides aminés hydrophobes ou chargés (Kim *et al.*, 2003).

D'autres cibles des Grx ont déjà été identifiées chez d'autres organismes. Ce sont souvent des facteurs de transcription ou des enzymes qui réagissent avec les Grx soit pour la réduction de ponts disulfures soit pour les phénomènes de S-thiolation (Björnstedt *et al.*, 1994 ; Davis *et al.*, 1997 ; Demple *et al.*, 1998 ; Barrett *et al.*, 1999 ; Shi *et al.*, 1999 ; Hirota *et al.*, 2000 ; Bandyopadhyay *et al.*, 2001, Daily *et al.*, 2001a ; Lillig *et al.*, 2003 ; Song *et al.*, 2003). En général, ces cibles sont également réduites par les Trx mais l'inverse est moins vrai. Il semble que l'explication principale soit le potentiel rédox plus électronégatif des Trx par rapport aux Grx.

Une particularité des Grx est l'existence de très nombreuses isoformes de Grx monocystéiniques alors que seulement 2 isoformes de Trx monocystéiniques ont été identifiées chez *A. thaliana*. En effet, ces Grx sont fonctionnelles et jouent un rôle essentiel notamment dans les phénomènes de S-thiolation comme la glutathionylation au même titre que les enzymes bicystéiniques (Klatt & Lamas, 2000 ; Starke *et al.*, 2003). Ce processus intervient souvent en réponse à un stress oxydant pour protéger les cystéines critiques de certaines enzymes contre une oxydation irréversible (Fratelli *et al.*, 2002). De manière surprenante, aucune information sur la glutathionylation chez les plantes n'est présente alors qu'elles possèdent un très grand nombre d'isoformes de Grx monocystéiniques. Par contre, quelques informations concernant la fonction de ces enzymes sont disponibles pour d'autres organismes. Parmi les 3 Grx monocystéiniques Grx 3, Grx 4, et Grx 5

identifiées chez *S. cerevisiae*, Grx 5, qui a une localisation mitochondriale, joue un rôle dans la réponse au stress oxydant, dans l'assemblage des centres fer-soufre et dans les phénomènes de S-thiolation (Rodriguez-Manzaneque *et al.*, 1999 ; Belli *et al.*, 2002 ; Rodriguez-Manzaneque *et al.*, 2002 ; Shenton *et al.*, 2002). De plus, un triple mutant de ces isoformes n'est pas viable démontrant l'importance de ces Grx à 1 cystéine (Rodriguez-Manzaneque *et al.*, 1999). Par ailleurs, les Grx 3 à 5 de *S. cerevisiae* et une Grx à 1 cystéine de *Plasmodium falciparum*, qui possèdent un site actif CGFS, sont homologues au motif protéique appelé PICOT-HD (Protein Kinase C Interacting Cousin of Thioredoxin Homology Domain) suggérant que ces protéines pourraient jouer un rôle dans la régulation de cette kinase (Isakov *et al.*, 2002 ; Rahlfs *et al.*, 2001).

## 2.2 Les connexions entre les systèmes Trx et Grx

Dans la plupart des cellules vivantes, l'équilibre rédox est maintenu par les systèmes TR/Trx et GR/GSH/Grx. Une des inconnues majeures est la relation entre ces systèmes *in vivo*.

Chez *S. cerevisiae*, il semble que la fonctionnalité d'un seul des deux systèmes est suffisante pour la viabilité (Draculic *et al.*, 2000). De plus, ces auteurs démontrent que le système Trx est maintenu réduit indépendamment du système GSH/Grx (Trotter & Grant, 2003).

Des données récentes indiquent qu'une Trx humaine est glutathionylée en réponse à un stress oxydant sur une des trois cystéines additionnelles à celles du site actif, lui faisant perdre sa capacité de réducteur (Casagrande *et al.*, 2002). Cette réaction est réversible puisque la Trx peut retrouver son activité après s'être déglutathionylée de manière auto-catalytique. Il est intéressant de noter également que l'activité de cette Trx peut aussi être régulée par nitrosylation sur une des 2 autres cystéines (Haendeler *et al.*, 2002). Certaines Trx ou Grx de plantes possèdent également des cystéines additionnelles qui pourraient être impliquées dans ce type de régulation.

Par ailleurs, il existe des organismes qui ne possèdent pas de voie de biosynthèse du GSH. C'est le cas de la plupart des bactéries Gram<sup>+</sup> et de bactéries Gram<sup>-</sup> telles qu'*H. pylori* ou *Haemophilus influenzae* (Comtois *et al.*, 2003 ; Vergauwen *et al.*, 2003). Ce dernier doit prélever du GSH chez son hôte afin de

l'utiliser pour réduire des protéines GSH dépendantes et notamment une protéine fusion entre des modules Prx et Grx impliquée dans la défense contre les ROS produit par les macrophages (Vergauwen *et al.*, 2003).

De plus, il semble qu'un système de réduction particulier ait évolué chez les insectes. En effet, aucune GR, homologue à celles caractérisées chez d'autres organismes n'a jamais été trouvée chez ces organismes qui possèdent néanmoins du GSH. Il a ainsi été démontré chez *D. melanogaster* notamment qu'un système TR/Trx était capable de réduire le glutathion oxydé (GSSG) (Kanzok *et al.*, 2001). Ce système n'est pas unique puisque le système Trx de *P. falciparum* est aussi capable de réduire le GSSG avec une plus grande efficacité que la GR (Kanzok *et al.*, 2000). Aucune activité de ce type n'a été détectée jusqu'à présent avec les Trx de peuplier.

Enfin, une sélénoprotéine comportant une Grx couplée à une Trx réductase NADPH dépendante a été mise en évidence chez les mammifères et certains parasites (Sun *et al.*, 2001 ; Agorio *et al.*, 2003). Cette enzyme fonctionne à la fois avec le GSH et avec la Trx constituant un système bifonctionnel inédit. Chez *Clostridium pasteurianum*, une fusion entre une TR NADH dépendante et une Grx a également été caractérisée (Reynolds *et al.*, 2002).

### 2.3 Les mécanismes de réduction catalytiques des Prx et des MsrA

L'activité de ces enzymes est basée sur la présence de cystéines réactives qui vont former des acides sulféniques (SOH) intermédiaires. Ces derniers pourront ensuite soit être réduits directement par les Trx ou les Grx soit être impliqués dans la formation de ponts disulfures intra ou intermoléculaires qui seront ensuite réduits par échange dithiol-disulfure avec les Trx et les Grx. Jusqu'à présent, peu de protéines ont été démontrées ayant un SOH en tant qu'intermédiaire réactionnel (Claiborne *et al.*, 2001). Ce sont essentiellement des disulfide réductases à FAD telles que les NADH peroxidases, NADH oxydases et GR, ou des protéines dépendantes des Trx ou des Grx, telles que les Prx, les MsrA et B, des tyrosine phosphatases et les facteurs de transcription AP1 (Activator Protein-1), OhrR (organic hydroperoxide resistance) et OxyR (Claiborne *et al.*, 2001 ; Fuangthong *et al.*, 2002).

Pour élucider d'une part le mécanisme catalytique de l'enzyme et d'autre part le mode d'interaction entre la cible et son réducteur, deux types d'approches ont été utilisées. La première a été d'isoler lorsque cela est possible des protéines de fusion

entre les modules à étudier alors que la deuxième a été de muter systématiquement les cystéines des protagonistes et de suivre l'activité des différentes protéines mutées selon toutes les combinaisons possibles.

Toutes les Prx possèdent une cystéine en position N-terminale, conservée quelles que soient les séquences de Prx considérées. Elle a été clairement établie comme la cystéine catalytique qui attaque les hydroperoxydes et qui est transformée en SOH. Néanmoins, la régénération de ces enzymes varie selon les types de Prx envisagés. Ce travail de mutagenèse a permis de mettre en évidence que la Prx de type II fonctionne avec une seule cystéine et surtout qu'elle accepte à la fois les Trx et les Grx pour la réduction du SOH formé au cours de la catalyse. De manière tout à fait intéressante, l'homologue de la Prx de type II chez les mammifères (Prx V) possède un pont disulfure intramoléculaire entre la cystéine catalytique et une autre cystéine située du côté C-terminal en position 152. Ce pont disulfure n'est réduit que par les Trx suggérant soit que le potentiel rédox de cette Prx constitue une barrière thermodynamique pour une réduction par la Grx, soit que l'interaction avec la Grx n'est pas possible à cause de l'absence de résidus spécifiques nécessaires à l'interaction ou pour des raisons de conformations spatiales inadaptées (Seo *et al.*, 2000). Jusqu'à présent c'est la seule isoforme de Prx de plante qui utilise la Grx en tant que donneur d'électrons. Les seuls autres exemples décrits dans la littérature sont la réduction d'une Gpx humaine par les systèmes Trx et Grx, la réduction d'une Prx appelée AhpC par la fusion NADH TR/Grx chez *Clostridium pasteurianum* et la réduction par le GSH d'une protéine de fusion entre une Grx et une Prx homologue aux Prx de type II de plantes chez *Chromatium gracile* et *H. influenzae* notamment (Björnstedt *et al.*, 1994 ; Vergauwen *et al.*, 2001 ; Reynolds *et al.*, 2002 ; Pauwels *et al.*, 2003). Une protéine de fusion Grx/Prx de *Neisseria meningitidis*, produite chez *E. coli* et purifiée, présente une activité de réduction des hydroperoxydes en présence de GSH (Rouhier *et al.*, résultats non publiés). Chaque module possède son activité de réduction spécifique dans la protéine de fusion mais aussi lorsque chaque module est isolé indépendamment.

L'autre isoforme de Prx caractérisée dans ce travail est une Prx Q, homologue à des protéines appelées BCP pour « bacterioferritin comigratory proteins ». Ces Prx possèdent généralement 2 résidus cystéinyles séparés par 4 acides aminés mais certains organismes possèdent des BCP avec la cystéine catalytique comme seule cystéine conservée (Jeong *et al.*, 2000). Au commencement de ce travail, il existait

une ambiguïté quant au mécanisme utilisé par cette enzyme puisque les 2 cystéines de la Prx Q de *Sedum lineare* étaient essentielles à l'activité de la protéine alors qu'une seule l'était pour la BCP d'*E. coli* (Jeong *et al.*, 2000 ; Kong *et al.*, 2000). Ce travail démontre la présence d'un pont disulfure intramoléculaire dans la Prx Q de peuplier qui ne sera réduit que par les Trx. Par contre, le mutant de la deuxième cystéine (Prx Q C51S), qui mime les séquences de BCP à une seule cystéine, conserve une activité de réduction des hydroperoxydes en présence des Trx ou des Grx, suggérant cette fois que les deux protéines sont capables de réduire le SOH formé. Dans ce cas, il semble que la Grx soit capable d'interagir avec la Prx Q mais pas de réduire le pont disulfure formé, là encore vraisemblablement pour un problème de différence de potentiel rédox insurmontable.

Pour les Prx, l'oxydation du SOH formé pendant la catalyse en acide sulfinique (SO<sub>2</sub>H) ou sulfonique (SO<sub>3</sub>H) était présumée jusqu'à maintenant être une modification irréversible de la protéine inactivant l'enzyme. Cet état sur-oxydé a été visualisé pour différentes Prx et se traduit par l'apparition d'une forme de Prx avec un pI plus acide observable par électrophorèse bidimensionnelle (Prouzet-Mauleon *et al.*, 2002 ; Rabilloud *et al.*, 2002 ; Yang *et al.*, 2002 ; Baker *et al.*, 2003). Pour la Prx de *S. cerevisiae* Ahp1 et la thiol peroxidase d'*E. coli*, l'inactivation est induite par des alkyl hydroperoxydes mais pas par H<sub>2</sub>O<sub>2</sub> (Prouzet-Mauleon *et al.*, 2002 ; Baker *et al.*, 2003). Pour les enzymes humaines, il semble qu'H<sub>2</sub>O<sub>2</sub> soit capable d'induire l'inactivation de la Prx seulement si celle-ci est engagée dans le cycle catalytique en présence du système Trx (Yang *et al.*, 2002b). Néanmoins, un article récent décrit la réduction d'un acide sulfinique de la Prx I de mammifère la rendant à nouveau active (Woo *et al.*, 2003). Dans le même temps, un autre article démontre l'existence d'une conformation structurale qui expliquerait pourquoi les Prx à 2 cystéines bactériennes sont moins sujettes à l'oxydation que leur homologue eucaryote (Wood *et al.*, 2003b). Cette sensibilité des enzymes eucaryotes est interprétée comme un moyen de faciliter la signalisation par H<sub>2</sub>O<sub>2</sub>.

Les Msr sont des enzymes connues depuis longtemps pour réduire les MetSO en Met et pour utiliser le système Trx comme donneur de pouvoir réducteur mais ce n'est que récemment que le mécanisme catalytique et le mode de régénération des MsrA et MsrB ont été mis en évidence chez *E. coli* (Boschi-Muller *et al.*, 2000 ; Grimaud *et al.*, 2001). Comme pour les Prx, ces enzymes comportent une cystéine

conservée qui passe également par un intermédiaire réactionnel SOH. Les alignements de séquences indiquent qu'il existe au moins 6 classes de MsrA qui diffèrent par la position des cystéines conservées et même une septième si on considère une MsrA de *C. reinhardtii* qui possède une sélénocystéine à la place de la cystéine catalytique (Novoselov *et al.*, 2002). Plusieurs observations nous ont conduits à nous intéresser à ces MsrA. Ces enzymes n'étaient caractérisées ni d'un point de vue biochimique, ni en terme de réducteurs physiologiques. Par ailleurs, l'observation que la croissance d'un mutant pour le gène *trxA* d'*E. coli* incapable de croître en présence de MetSO, est restaurée par surexpression de la Grx 1, laissait présager une possible réduction des Msr par les Grx (Stewart *et al.*, 1998). De plus, l'existence d'une protéine de fusion entre deux modules Grx et un module MsrA chez *Gracilaria gracilis* était un autre indice fort de cette interaction possible. Ainsi, dans notre recherche de protéines cibles des Grx, deux isoformes de MsrA ont été isolées, leur mécanisme catalytique et leur mode de réduction examinés. Les expériences de mutagenèse dirigée indiquent que trois cystéines sont essentielles à une activité Trx dépendante des MsrA mais aucune activité Grx dépendante des MsrA de peuplier n'a été observée jusqu'à présent. Malgré une identité de séquences assez faible (42%) notamment du côté C-terminal de la protéine et une structure quelque peu divergente, il apparaît que les mécanismes catalytiques et de régénération par les Trx des MsrA de plantes sont similaires à ceux d'*E. coli*. Par contre, l'enzyme de *G. gracilis* possède bien une activité de réduction de la MetSO en présence de DTT ou de GSH (Rouhier *et al.*, résultats non publiés). La structure cristallographique de l'enzyme plastidiale a été résolue et indique, comme pour les autres structures connues de Msr, qu'un important changement conformationnel est nécessaire pour corroborer les résultats issus de la mutagenèse sur le mécanisme catalytique. Néanmoins, la rotation de la boucle C-terminale au niveau de 2 résidus glycinyll pourrait permettre d'obtenir une conformation et des distances entre les cystéines adaptées pour la catalyse.

### 3. Expression et localisation de ces protéines

La disponibilité de 115 000 séquences EST de peuplier issues de diverses banques d'ADNc permet d'estimer et de compléter des profils d'expression de chacun des gènes étudiés. Avant de discuter les profils d'expression des différents



gènes ou protéines, il est important de noter que chaque conclusion est basée sur l'analyse de plants non stressés s'étant développés dans des conditions définies. On peut donc imaginer que l'expression de la protéine puisse être induite dans des conditions précises de développement ou lors de réponse à des conditions changeantes. Ainsi, *poptrx h1* est exprimé dans les feuilles, les tiges et les racines et la protéine peut être détectée dans les feuilles et les racines mais pas dans les tiges. Ces résultats sont confirmés par l'analyse de séquences EST de peuplier. 68 séquences nucléotidiques correspondent à cette isoforme ce qui en ferait la *trx* la plus exprimée. Les ADNc sont présents principalement dans les feuilles, les racines, les tissus conducteurs et les fleurs. *Poptrx h2* est exprimée à des niveaux détectables seulement dans les feuilles et les racines mais la protéine est trouvée dans ces 2 organes et dans les tiges (résultats non publiés, Gelhaye *et al.*). L'analyse des 50 séquences EST de *poptrx h2* confirme ces résultats puisque 80% des séquences sont d'origine foliaire et 10% sont des EST de racine et de pétiole. Aucune étude d'expression n'a encore été effectuée pour *popTrx h3*. Seulement 9 séquences EST codant pour *popTrx h3* sont détectées, 3 dans les racines, 2 dans les graines imbibées, et 1 dans les tissus apicaux, les fleurs, les pétioles et le cambium.

La Grx de peuplier est exprimée à des niveaux identiques dans les 3 organes testés, feuilles, tiges et racines (Rouhier *et al.*, résultats non publiés). D'après les séquences EST trouvées dans les différentes banques d'ADNc, les transcrits codant pour cette Grx seraient présents dans les racines et les fleurs essentiellement mais aussi dans les tissus apicaux, les tissus conducteurs et les graines imbibées.

Parmi les Prx, la Prx de type II est l'isoforme la plus exprimée puisque parmi les 115000 EST, 69 correspondent aux Prx de type II, 13 aux Prx à 2 cystéines, 9 aux Prx Q et 2 aux Prx à 1 cystéine.

Les expériences de northern blot indiquent que les transcrits codant pour la Prx de type II sont présent dans les feuilles, les tiges et les racines. L'analyse des EST disponibles confirme ces résultats et indique également que les transcrits sont présents dans les graines et dans les fleurs en forte proportion. Au niveau protéique, la présence de la Prx de type II est détectée dans les 3 organes testés, feuilles, tiges, et racines. Par ailleurs, des études plus précises d'immunolocalisation démontrent que la protéine est située dans le phloème au niveau des tubes criblés.

Le gène codant la Prx Q paraît peu exprimé puisqu'on ne retrouve que 9 EST dans la base de donnée, 4 sont issues de la banque d'ADNc de feuille, 3 de la banque d'écorce et 2 de la banque de fleur. La protéine n'est détectée que dans les feuilles par western blot mais pas dans les tiges et les racines. Par ailleurs, la localisation chloroplastique de la protéine a été déterminée par des expériences de fluorescence et de microscopie électronique. Enfin, cette protéine semble impliquée dans les mécanismes de réponse à une attaque pathogène. En effet, la quantité de protéine augmente en fonction du temps lors d'une interaction avec une race incompatible de *Melampsora larici-populina* alors qu'elle décroît lors d'une réaction avec une race compatible. Lors d'une réaction incompatible, un phénomène de mort cellulaire programmée qu'on appelle réponse hypersensible se met en place. Lors de cette réponse hypersensible, de grandes quantités d'H<sub>2</sub>O<sub>2</sub> sont produites et on peut donc imaginer que la Prx Q ait un rôle à jouer dans le contrôle de ce phénomène.

Pour les *msrA*, l'analyse des séquences EST permet de distinguer 2 isoformes qui sont celles que l'on a isolé, alors que 4 isoformes sont présentes chez *A. thaliana*. Les 2 *msrA* paraissent peu exprimés, seulement 10 et 7 EST codant respectivement pour la cMsrA et la pMsrA. Pour *cmsrA*, les transcrits sont présents dans les racines, les fleurs, les feuilles et le bois et pour *pmsrA*, dans les feuilles, les racines, les fleurs et le bois. Au niveau protéique, les premières expériences indiquent que la pMsrA est exprimée dans les feuilles, les tiges et les racines alors que la cMsrA est difficilement détectable avec les anticorps dirigés contre la pMsrA, vraisemblablement parce que la protéine est peu exprimée car ces anticorps reconnaissent parfaitement la protéine recombinante (Rouhier *et al.*, résultats non publiés). Par ailleurs, la quantité de ces protéines ne varie pas en réponse à une attaque pathogène par *M. larici-populina* (Rouhier *et al.*, résultats non publiés).

#### 4. Les structures tridimensionnelles

Les Trx, Grx et Prx ont toutes une structure tridimensionnelle similaire basée sur ce que l'on appelle en anglais le « thioredoxin fold » alors que ces protéines n'ont pas du tout la même séquence primaire ni la même fonction excepté pour les Trx et les Grx (Schröder & Ponting, 1998). Les MsrA ont aussi par certains aspects une structure similaire aux Trx (Gladyshev *et al.*, 2002).

Au cours de ma thèse, la collaboration entreprise avec le laboratoire de cristallographie de Nancy a d'ores et déjà permis de résoudre la structure de 3 protéines, la Grx en complexe avec le GSH, la Prx de type II et la pMsrA. Toutes trois sont dans leur famille les premières structures pour des enzymes de plante. Ces structures permettent d'appréhender notamment l'accessibilité et la conformation du site actif de l'enzyme et la répartition des charges en surface de la protéine. Par conséquent, elles représentent un outil indispensable pour étudier les interactions protéine-protéine ou protéine-substrat.



## *Perspectives*

Le travail de caractérisation entrepris sur les Trx, les Grx et leurs protéines cibles ainsi que l'apparition récente dans la base de données GenBank de nombreuses séquences EST ouvrent des perspectives intéressantes. Quelques-unes d'entre elles sont listées ci-dessous :

- Isoler de nouvelles isoformes de Trx, Grx, Prx et MsrA afin de comparer leurs propriétés biochimiques, leurs expressions et déterminer leurs fonctions dans la cellule.
- Déterminer les interactions à l'origine de la reconnaissance entre les Trx et les Grx et leurs protéines cibles soit par résolution de la structure des protéines en complexe soit en étudiant au niveau structural et biochimique d'éventuelles protéines de fusion.
- Poursuivre l'étude de l'expression de ces diverses protéines lors de la croissance du peuplier ou en réponse à divers stress.
- Identifier de nouvelles protéines cibles des différentes Trx et Grx isolées en utilisant les outils de la protéomique et les EST disponibles.
- Etudier par RMN les changements structuraux qui interviennent lors de l'interaction Grx-Prx de type II.
- Etudier le transcriptome et le protéome de plants de peuplier infectés par la rouille.
- Transformer des plants de peuplier par certains de gènes pour augmenter leur résistance.



## *Références*



## A

Abrahams JP, Leslie AGW. (1996) Methods used in the structure determination of bovine mitochondrial F1 ATPase. *Acta Crystallogr. D Biol. Crystallogr.* 52 :30-42.

Agorio A, Chalar C, Cardozo S, Salinas G. (2003) Alternative mRNAs arising from trans-splicing code for mitochondrial and cytosolic variants of *Echinococcus granulosus* thioredoxin glutathione reductase. *J. Biol. Chem.* 278:12920-12928.

Aguilar F, Brunner B, Gardet-Salvi L, Stutz E, Schurmann P. (1992) Biosynthesis of active spinach-chloroplast thioredoxin f in transformed *E. coli*. *Plant Mol. Biol.* 20:301-306.

Alphey MS, Bond CS, Tetaud E, Fairlamb AH, Hunter WN. (2000) The structure of reduced trypanothione peroxidase reveals a decamer and insight into reactivity of 2Cys-peroxiredoxins. *J. Mol. Biol.* 300:903-916.

Altschul SF, Gish W, Miller W, Myers EW, Lipman DJ. (1990) Basic local alignment search tool. *J. Mol. Biol.* 215:403-410.

Anderson LE, Li AD, Stevens FJ. (1998) The enolases of ice plant and *Arabidopsis* contain a potential disulphide and are redox sensitive. *Phytochemistry* 47:707-713.

Asada K. (1992) Ascorbate peroxidase a hydrogen peroxide scavenging enzyme in plants. *Physiol. Plant.* 85:235-241.

Asada K. (1999) The water-water cycle in chloroplasts: scavenging of active oxygen and dissipation of excess photons. *Annu. Rev. Plant Physiol. Plan Mol. Biol.* 50:601-639.

Aslund F, Ehn B, Miranda-Vizuete A, Pueyo C, Holmgren A. (1994) Two additional glutaredoxins exist in *Escherichia coli*: glutaredoxin 3 is a hydrogen donor for ribonucleotide reductase in a thioredoxin/glutaredoxin 1 double mutant. *Proc. Natl. Acad. Sci. USA* 91:9813-9817.

Aslund F, Berndt KD, Holmgren A. (1997) Redox potentials of glutaredoxins and other thiol-disulfide oxidoreductases of the thioredoxin superfamily determined by direct protein-protein redox equilibria. *J. Biol. Chem.* 272:30780-30786.

Aslund F, Beckwith J. (1999) Bridge over troubled waters : sensing stress by disulfide bond formation. *Cell* 96:751-753.

Aslund F, Zheng M, Beckwith J, Storz G. (1999) Regulation of the OxyR transcription factor by hydrogen peroxide and the cellular thiol-disulfide status. *Proc. Natl. Acad. Sci. USA* 96:6161-6165.

## B

Baalmann E, Backhausen JE, Rak C, Vetter S, Scheibe R. (1995) Reductive modification and non reductive activation of purified spinach chloroplast NADP-dependent glyceraldehyde-3-phosphate dehydrogenase. *Arch. Biochem. Biophys.* 324:201-208.

Babychuk E, Kushnir S, Van Montagu M, Inze D. (1994) The *Arabidopsis thaliana* apurinic endonuclease Arp reduces human transcription factors Fos and Jun. *Proc. Natl. Acad. Sci. USA* 91:3299-3303.

Baier M, Dietz KJ. (1996) Primary structure and expression of plant homologues of animal and fungal thioredoxin-dependent peroxide reductases and bacterial alkyl hydroperoxide reductases. *Plant Mol. Biol.* 31:553-564.

Baier M, Dietz KJ. (1997) The plant 2-Cys peroxiredoxin BAS1 is a nuclear-encoded chloroplast protein: its expressional regulation, phylogenetic origin, and implications for its specific physiological function in plants. *Plant J.* 12:179-190.

Baier M, Dietz KJ. (1999a) Protective function of chloroplast 2-cysteine peroxiredoxin in photosynthesis. Evidence from transgenic *Arabidopsis*. Plant Physiol. 119:1407-1414.

Baier M, Dietz KJ. (1999b) Alkyl hydroperoxide reductases: the way out of the oxidative breakdown of lipids in chloroplasts. Trends Plant Sci. 4:166-168.

Baier M, Dietz KJ. (1999c) The costs and benefits of oxygen for photosynthesizing plant cells. Prog. Botany 60:282-314.

Baier M, Noctor G, Foyer CH, Dietz KJ. (2000) Antisense suppression of 2-cysteine peroxiredoxin in *Arabidopsis* specifically enhances the activities and expression of enzymes associated with ascorbate metabolism but not glutathione metabolism. Plant Physiol. 124:823-832.

Baker LM, Raudonikiene A, Hoffman PS, Poole LB. (2001) Essential thioredoxin-dependent peroxiredoxin system from *Helicobacter pylori*: genetic and kinetic characterization. J. Bacteriol. 183:1961-1973.

Baker LM, Poole LB. (2003) Catalytic mechanism of thiol peroxidase from *Escherichia coli*. Sulfenic acid formation and overoxidation of essential CYS61. J. Biol. Chem. 278:9203-9211.

Ballicora MA, Frueauf JB, Fu Y, Schurmann P, Preiss J. (2000) Activation of the potato tuber ADP-glucose pyrophosphorylase by thioredoxin. J. Biol. Chem. 275:1315-1320.

Balmer Y, Schurmann P. (2001) Heterodimer formation between thioredoxin f and fructose 1,6-bisphosphatase from spinach chloroplasts. FEBS Lett. 492:58-61.

Balmer Y, Stritt-Etter AL, Hirasawa M, Jacquot JP, Keryer E, Knaff DB, Schurmann P. (2001) Oxidation-reduction and activation properties of chloroplast fructose 1,6-bisphosphatase with mutated regulatory site. Biochemistry 40:15444-15450.

Balmer Y, Koller A, del Val G, Manieri W, Schurmann P, Buchanan BB. (2003) Proteomics gives insight into the regulatory function of chloroplast thioredoxins. Proc. Natl. Acad. Sci. USA 100:370-375.

Bandyopadhyay S, Starke DW, Mieyal JJ, Gronostajski RM. (1998) Thioltransferase (glutaredoxin) reactivates the DNA-binding activity of oxidation-inactivated nuclear factor I. J. Biol. Chem. 273:392-397.

Bao Y, Jemth P, Mannervik B, Williamson G. (1997) Reduction of thymine hydroperoxide by phospholipid hydroperoxide glutathione peroxidase and glutathione transferases. FEBS Lett. 410:210-212.

Bar-Noy S, Moskovitz J. (2002) Mouse methionine sulfoxide reductase B: effect of selenocysteine incorporation on its activity and expression of the seleno-containing enzyme in bacterial and mammalian cells. Biochem. Biophys. Res. Commun. 97:956-961.

Barr SD, Gedamu L. (2001) Cloning and characterization of three differentially expressed peroxidoxin genes from *Leishmania chagasi*. Evidence for an enzymatic detoxification of hydroxyl radicals. J. Biol. Chem. 276:34279-34287.

Barrett WC, DeGnore JP, Konig S, Fales HM, Keng YF, Zhang ZY, Yim MB, Chock PB. (1999) Regulation of PTP1B via glutathionylation of the active site cysteine 215. Biochemistry 38:6699-6705.

Bauer H, Kanzok SM, Schirmer RH. (2002) Thioredoxin-2 but not thioredoxin-1 is a substrate of thioredoxin peroxidase-1 from *Drosophila melanogaster*: isolation and characterization of a second thioredoxin in *D. Melanogaster* and evidence for distinct biological functions of Trx-1 and Trx-2. J. Biol. Chem. 277:17457-17463.

Beckman KB, Ames BN. (1997) Oxidative decay of DNA. J. Biol. Chem. 272:19633-19636.

Beeor-Tzahar T, Ben-Hayyim G, Holland D, Faltin Z, Eshdat Y. (1995) A stress-associated citrus protein is a distinct plant phospholipid hydroperoxide glutathione peroxidase. *FEBS Lett.* 66:151-155.

Behm M, Jacquot JP. (2000) Isolation and characterization of thioredoxin h from poplar xylem. *Plant Physiol. Biochem.* 38:363-369.

Belli G, Polaina J, Tamarit J, De La Torre MA, Rodriguez-Manzanique MT, Ros J, Herrero E. (2002) Structure-function analysis of yeast Grx5 monothiol glutaredoxin defines essential amino acids for the function of the protein. *J. Biol. Chem.* 277:37590-37596.

Berardi MJ, Bushweller JH. (1999) Binding specificity and mechanistic insight into glutaredoxin-catalyzed protein disulfide reduction. *J. Mol. Biol.* 292:151-161.

Berggren MI, Husbeck B, Samulitis B, Baker AF, Gallegos A, Powis G. (2001) thioredoxin peroxidase-1 (peroxiredoxin-1) is increased in thioredoxin-1 transfected cells and results in enhanced protection against apoptosis caused by hydrogen peroxide but not by other agents including dexamethasone, etoposide, and doxorubicin. *Arch. Biochem. Biophys.* 392:103-109.

Berlett BS, Stadtman ER. (1997) Protein oxidation in aging, disease, and oxidative stress. *J. Biol. Chem.* 272:20313-20316.

Besse I, Wong JH, Kobrehel K, Buchanan BB. (1996) Thiocalcin: a thioredoxin-linked, substrate-specific protease dependent on calcium. *Proc. Natl. Acad. Sci. USA* 93:3169-3175.

Bestwick CS, Brown IR, Bennett MH, Mansfield JW. (1997) Localization of hydrogen peroxide accumulation during the hypersensitive reaction of lettuce cells to *Pseudomonas syringae* pv *phaseolicola*. *Plant Cell* 9:209-221.

Bick JA, Aslund F, Chen Y, Leustek T. (1998) Glutaredoxin function for the carboxyl-terminal domain of the plant-type 5'-adenylylsulfate reductase. Proc. Natl. Acad. Sci. USA 95:8404-8409.

Bick JA, Dennis JJ, Zylstra GJ, Nowack J, and Leustek T. (2000) Identification of a new class of 5'-adenylylsulfate (APS) reductases from sulfate-assimilating bacteria. J. Bacteriol. 182:135-142.

Binda C, Coda A, Aliverti A, Zanetti G, Mattevi A. (1998) Structure of the mutant E92K of [2Fe-2S] ferredoxin I from *Spinacia oleracea* at 1.7 Å resolution. Acta Crystallogr. D Biol. Crystallogr. 54:1353-1358.

Bjornstedt M, Xue J, Huang W, Akesson B, Holmgren A. (1994) The thioredoxin and glutaredoxin systems are efficient electron donors to human plasma glutathione peroxidase. J. Biol. Chem. 269:29382-29384.

Boschi-Muller S, Azza S, Sanglier-Cianferani S, Talfournier F, Van Dorsselear A, Branlant G. (2000) A sulfenic acid enzyme intermediate is involved in the catalytic mechanism of peptide methionine sulfoxide reductase from *Escherichia coli*. J. Biol. Chem. 275:35908-35913.

Boschi-Muller S, Azza S, Branlant G. (2001) *E. coli* methionine sulfoxide reductase with a truncated N terminus or C terminus, or both, retains the ability to reduce methionine sulfoxide. Protein Sci. 10:2272-2279.

Bower MS, Matias DD, Fernandes-Carvalho E, Mazzurco M, Gu T, Rothstein SJ, Goring DR. (1996) Two members of the thioredoxin-h family interact with the kinase domain of a Brassica S locus receptor kinase. Plant Cell 8:1641-1650.

Brandes HK, Larimer FW, Hartman FC.. (1996) The molecular pathway for the regulation of phosphoribulokinase by thioredoxin f. J. Biol. Chem. 271:3333-3335.

Brehelin C, Mouaheb N, Verdoucq L, Lancelin JM, Meyer Y. (2000) Characterization of determinants for the specificity of *Arabidopsis* thioredoxins h in yeast complementation. J. Biol. Chem. 275:31641-31647.

Broin M, Cuine S, Peltier G, Rey P. (2000) Involvement of CDSP 32, a drought-induced thioredoxin, in the response to oxidative stress in potato plants. FEBS Lett. 467:245-248.

Broin M, Cuine S, Eymery F, Rey P. (2002) The plastidic 2-cysteine peroxiredoxin is a target for a thioredoxin involved in the protection of the photosynthetic apparatus against oxidative damage. Plant Cell 14:1417-1432.

Brot N, Weissbach H. (2000) Peptide methionine sulfoxide reductase: biochemistry and physiological role. Biopolymers 55:288-296.

Brugidou C, Marty I, Chartier and Meyer Y. (1993) The *Nicotiana tabacum* genome encodes two cytoplasmic thioredoxin genes which are differently expressed. Mol. Gen. Genet. 238:285-293.

Brumlik MJ, van der Goot FG, Wong KR, and Buckley JT. (1997) The disulfide bond in the *Aeromonas hydrophila* lipase/acyltransferase stabilizes the structure but is not required for secretion or activity. J. Bacteriol. 179:3116-3121.

Brunger AT, Adams PD, Clore GM, DeLano WL, Gros P, Grosse-Kunstleve RW, Jiang JS, Kuszewski J, Nilges M, Pannu NS, Read RJ, Rice LM, Simonson T, Warren GL. (1998) Crystallography & NMR system : A new software suite for macromolecular structure determination. Acta Crystallogr. D Biol. Crystallogr. 54:905-921.

Bryk R, Griffin P, Nathan C. (2000) Peroxynitrite reductase activity of bacterial peroxiredoxins. Nature 407:211-215.

Bryk R, Lima CD, Erdjument-Bromage H, Tempst P, Nathan C. (2002) Metabolic enzymes of mycobacteria linked to antioxidant defense by a thioredoxin-like protein. *Science* 295:1073-1077.

Buchanan BB, Schürmann P, Decottignies P, Lozano RM. (1994) Thioredoxin: a multifunctional regulatory protein with a bright future in technology and medicine. *Arch. Biochem. Biophys.* 314:257-260.

Buchanan BB, Schurmann P, Jacquot JP. (1994) Thioredoxin and metabolic regulation. *Semin. Cell. Biol.* 5:285-293.

Buchanan BB, Schürmann P, Wolosiuk RA, Jacquot JP. (2002) The ferredoxin/thioredoxin system: from discovery to molecular structures and beyond. *Photosynth. Res.* 73:215-222.

Bucheler US, Werner D, Schirmer RH. (1990) Random silent mutagenesis in the initial triplets of the coding region: a technique for adapting human glutathione reductase-encoding cDNA to expression in *Escherichia coli*. *Gene* 96:271-276.

Buettner GR, Jurkiewicz BA. (1996) Chemistry and biochemistry of ascorbic acid. *Handbook of antioxidant*, ed. E cadenas, L Packer, pp91-115. New York : Dekker.

Bunik V, Raddatz G, Lemaire S, Meyer Y, Jacquot JP, Bisswanger H. (1999) Interaction of thioredoxins with target proteins: role of particular structural elements and electrostatic properties of thioredoxins in their interplay with 2-oxoacid dehydrogenase complexes. *Protein Sci.* 8:65-74.

Bushweller JH, Aslund F, Wuthrich K, Holmgren A. (1992) Structural and functional characterization of the mutant *Escherichia coli* glutaredoxin (C14----S) and its mixed disulfide with glutathione. *Biochemistry* 31:9288-9293.

**C**



Capitani G, Markovic-Housley Z, DeVal G, Morris M, Jansonius JN, Schurmann P. (2000) Crystal structures of two functionally different thioredoxins in spinach chloroplasts. *J. Mol. Biol.* 302:135-154.

Carmel-Harel O, Storz G. (2000) Roles of the glutathione- and thioredoxin-dependent reduction systems in the *Escherichia coli* and *Saccharomyces cerevisiae* responses to oxidative stress. *Annu. Rev. Microbiol.* 54:439-461.

Casagrande S, Bonetto V, Fratelli M, Gianazza E, Eberini I, Massignan T, Salmona M, Chang G, Holmgren A, Ghezzi P. (2002) Glutathionylation of human thioredoxin: a possible crosstalk between the glutathione and thioredoxin systems. *Proc. Natl. Acad. Sci. USA.* 99:9745-9749.

Chae HZ, Chung SJ, Rhee SG. (1994) Thioredoxin-dependent peroxide reductase from yeast. *J. Biol. Chem.* 269:27670-27678.

Chae HZ, Uhm TB, Rhee SG. (1994) Dimerization of thiol-specific antioxidant and the essential role of cysteine 47. *Proc. Natl. Acad. Sci. USA* 91:7022-7026.

Chae HZ, Kim HJ, Kang SW, Rhee SG. (1999) Characterization of three isoforms of mammalian peroxiredoxin that reduce peroxides in the presence of thioredoxin. *Diabetes Res. Clin. Pract.* 45:101-112.

Chen L, Xie QW, Nathan C. (1998) Alkyl hydroperoxide reductase subunit C (AhpC) protects bacterial and human cells against reactive nitrogen intermediates. *Mol. Cell.* 1:795-805.

Cheong NE, Choi YO, Lee KO, Kim WY, Jung BG, Chi YH, Jeong JS, Kim K, Cho MJ, Lee SY. (1999) Molecular cloning, expression, and functional characterization of a 2Cys-peroxiredoxin in *Chinese cabbage*. *Plant Mol. Biol.* 40:825-834.

Chiadmi M, Navaza A, Miginiac-Maslow M, Jacquot JP, Cherfils J. (1999) Redox signalling in the chloroplast: structure of oxidized pea fructose-1,6-bisphosphate phosphatase. *EMBO J.* 18:6809-6815.

Chivers PT, Prehoda KE, Raines RT. (1997) The CXXC motif: a rheostat in the active site. *Biochemistry* 36:4061-4066.

Choi HJ, Kang SW, Yang CH, Rhee SG, Ryu SE. (1998) Crystal structure of a novel human peroxidase enzyme at 2.0 Å resolution. *Nat. Struct. Biol.* 5:400-406.

Choi YO, Cheong NE, Lee KO, Jung BG, Hong CH, Jeong JH, Chi YH, Kim K, Cho MJ, Lee SY. (1999) Cloning and expression of a new isotype of the peroxiredoxin gene of *Chinese cabbage* and its comparison to 2Cys-peroxiredoxin isolated from the same plant. *Biochem. Biophys. Res. Commun.* 258:768-771.

Chrestensen CA, Starke DW, Mieyal JJ. (2000) Acute cadmium exposure inactivates thioltransferase (Glutaredoxin), inhibits intracellular reduction of protein-glutathionyl-mixed disulfides, and initiates apoptosis. *J. Biol. Chem.* 275:26556-26565.

Ciaffi M, Paolacci AR, Dominici L, Tanzarella OA, Porceddu E. (2001) Molecular characterization of gene sequences coding for protein disulfide isomerase (PDI) in durum wheat (*Triticum turgidum ssp. durum*). *Gene* 265:147-156.

Ciorba MA, Heinemann SH, Weissbach H, Brot N, Hoshi T. (1997) Modulation of potassium channel function by methionine oxidation and reduction. *Proc. Natl. Acad. Sci. USA* 94:9932-9937.

Ciorba MA, Heinemann SH, Weissbach H, Brot N, Hoshi T. (1999) Regulation of voltage-dependent K<sup>+</sup> channels by methionine oxidation: effect of nitric oxide and vitamin C. *FEBS Lett.* 442:48-52.

Claiborne A, Yeh JI, Mallett TC, Luba J, Crane EJ, Charrier V, Parsonage D. (1999) Protein-sulfenic acids: diverse roles for an unlikely player in enzyme catalysis and redox regulation. *Biochemistry* 38:15407-15416.

Claiborne A, Mallett TC, Yeh JI, Luba J, Parsonage D. (2001) Structural, redox, and mechanistic parameters for cysteine-sulfenic acid function in catalysis and regulation. *Adv. Protein. Chem.* 58:215-276.

Collet JF, Riemer J, Bader MW, Bardwell JC. (2002) Reconstitution of a disulfide isomerization system. *J. Biol. Chem.* 277:26886-26892.

Collin V, Issakidis-Bourguet E, Marchand C, Hirasawa M, Lancelin JM, Knaff DB, Miginiac-Maslow M. (2003) The *Arabidopsis* plastidial thioredoxins: new functions and new insights into specificity. *J. Biol. Chem.* In press.

Collinson EJ, Wheeler GL, Garrido EO, Avery AM, Avery SV, Grant CM. (2002) The yeast glutaredoxins are active as glutathione peroxidases. *J. Biol. Chem.* 277:16712-16717.

Comtois SL, Gidley MD, Kelly DJ. (2003) Role of the thioredoxin system and the thiol-peroxidases Tpx and Bcp in mediating resistance to oxidative and nitrosative stress in *Helicobacter pylori*. *Microbiology* 149:121-129.

Cooper CE, Patel RP, Brookes PS, Darley-Usmar VM. (2002) Nanotransducers in cellular redox signaling: modification of thiols by reactive oxygen and nitrogen species. *Trends Biochem. Sci.* 27:489-492.

Costa Seaver L, Imlay JA. (2001) Alkyl hydroperoxide reductase is the primary scavenger of endogenous hydrogen peroxide in *Escherichia coli*. *J. Bacteriol.* 183:7173-7181.

Cudney R, Patel S, Weisgraber K, Newhouse Y, McPherson A. (1994) Screening and optimization strategies for macromolecular crystal growth. *Acta Crystallogr. D Biol. Crystallogr.* 50:414-423.

**D**

Dai S, Saarinen M, Ramaswamy S, Meyer Y, Jacquot JP, Eklund H. (1996) Crystal structure of *Arabidopsis thaliana* NADPH dependent thioredoxin reductase at 2.5 Å resolution. *J. Mol. Biol.* 264:1044-1057.

Dai S, Schwendtmayer C, Johansson K, Ramaswamy S, Schurmann P, Eklund H. (2000) How does light regulate chloroplast enzymes? Structure-function studies of the ferredoxin/thioredoxin system. *Q. Rev. Biophys.* 33:67-108.

Dai S, Schwendtmayer C, Schurmann P, Ramaswamy S, and Eklund H. (2000) Redox signaling in chloroplasts: cleavage of disulfides by an iron-sulfur cluster. *Science* 287:655-658.

Daily D, Vlamis-Gardikas A, Offen D, Mittelman L, Melamed E, Holmgren A, Barzilai A. (2001a) Glutaredoxin protects cerebellar granule neurons from dopamine-induced apoptosis by activating NF-kappa B via Ref-1. *J. Biol. Chem.* 276:1335-1344.

Daily D, Vlamis-Gardikas A, Offen D, Mittelman L, Melamed E, Holmgren A, Barzilai A. (2001) Glutaredoxin protects cerebellar granule neurons from dopamine-induced apoptosis by dual activation of the ras-phosphoinositide 3-kinase and jun n-terminal kinase pathways. *J. Biol. Chem.* 276:21618-21626.

Davis DA, Newcomb FM, Starke DW, Ott DE, Mieyal JJ, Yarchoan R. (1997) Thioltransferase (glutaredoxin) is detected within HIV-1 and can regulate the activity of glutathionylated HIV-1 protease *in vitro*. *J. Biol. Chem.* 272:25935-25940.

Debarbieux L, Beckwith J. (1999) Electron avenue: pathways of disulfide bond formation and isomerization. *Cell* 99:117-119.

Declercq JP, Evrard C, Clippe A, Stricht DV, Bernard A, Knoops B. (2001) Crystal structure of human peroxiredoxin 5, a novel type of mammalian peroxiredoxin at 1.5 Å resolution. *J. Mol. Biol.* 311:751-759.

Decottignies P, Schmitter JM, Miginiac-Maslow M, Le Marechal P, Jacquot JP, Gadal P. (1988) Primary structure of the light-dependent regulatory site of corn NADP-malate dehydrogenase. *J. Biol. Chem.* 263:11780-11785.

Delledonne M, Zeier J, Marocco A, Lamb C. (2001) Signal interactions between nitric oxide and reactive oxygen intermediates in the plant hypersensitive disease resistance response. *Proc. Natl. Acad. Sci. USA* 98:13454-13459.

Demple B. (1998) A bridge to control. *Science* 279:1655-1656.

Dhandayuthapani S, Blaylock MW, Bebear CM, Rasmussen WG, Baseman JB. (2001) Peptide methionine sulfoxide reductase (MsrA) is a virulence determinant in *Mycoplasma genitalium*. *J. Bacteriol.* 183:5645-5650.

Dietz KJ, Horling F, König J, Baier M. (2002) The function of the chloroplast 2-cysteine peroxiredoxin in peroxide detoxification and its regulation. *J. Exp. Bot.* 53:1321-1329.

Dixon DP, Laphorn A, Edwards R. (2002) Plant glutathione transferases. *Genome Biol.* 3:1-10.

Do HM, Hong JK, Jung HW, Kim SH, Ham JH, Hwang BK. (2003) Expression of peroxidase-like genes, H<sub>2</sub>O<sub>2</sub> production, and peroxidase activity during the hypersensitive response to *Xanthomonas campestris* pv. *vesicatoria* in *Capsicum annuum*. *Mol. Plant Microbe Interact.* 16:196-205.

Draculic T, Dawes IW, Grant CM. (2000) A single glutaredoxin or thioredoxin gene is essential for viability in the yeast *Saccharomyces cerevisiae*. *Mol. Microbiol.* 36:1167-1174.

Dunford RP, Catley MA, Raines CA, Lloyd JC, Dyer TA. (1998) Purification of active chloroplast sedoheptulose-1,7-bisphosphatase expressed in *Escherichia coli*. *Protein Expr. Purif.* 14:139-145.

Dyson HJ, Jeng MF, Tennant LL, Slaby I, Lindell M, Cui DS, Kuprin S, Holmgren A. (1997) Effects of buried charged groups on cysteine thiol ionization and reactivity in *Escherichia coli* thioredoxin: structural and functional characterization of mutants of Asp 26 and Lys 57. *Biochemistry* 36:2622-2636.

## E

Ejiri SI, Weissbach H, Brot N. (1979) Reduction of methionine sulfoxide to methionine by *Escherichia coli*. *J. Bacteriol.* 139:161-164.

Eklund H, Cambillau C, Sjoberg BM, Holmgren A, Jornvall H, Hoog JO, Branden CI. (1984) Conformational and functional similarities between glutaredoxin and thioredoxins. *EMBO J.* 3:1443-1449.

Eklund H, Ingelman M, Soderberg BO, Uhlin T, Nordlund P, Nikkola M, Sonnerstam U, Joelson T, Petratos K. (1992) Structure of oxidized bacteriophage T4 glutaredoxin (thioredoxin). Refinement of native and mutant proteins. *J. Mol. Biol.* 228:596-618.

Enright AJ, Iliopoulos I, Kyripides NC, Ouzounis CA. (1999) Protein interaction maps for complete genomes based on gene fusion events. *Nature* 402:86-90.

Entus R, Poling M, Herrmann KM. (2002) Redox regulation of *Arabidopsis* 3-deoxy-D-arabino-heptulosonate 7-phosphate synthase. *Plant Physiol.* 129:1866-1871.

Etienne F, Spector D, Brot N, Weissbach H. (2003) A methionine sulfoxide reductase in *Escherichia coli* that reduces the R enantiomer of methionine sulfoxide. *Biochem. Biophys. Res. Commun.* 300:378-382.

## F

Finkel T, Holbrook NJ. (2000) Oxidants, oxidative stress and the biology of ageing. *Nature* 408:239-247.

Fischer N, Hippler M, Setif P, Jacquot JP, Rochaix JD. (1998) The PsaC subunit of photosystem I provides an essential lysine residue for fast electron transfer to ferredoxin. *EMBO J.* 17:849-858.

Flohe L, Budde H, Bruns K, Castro H, Clos J, Hofmann B, Kansal-Kalavar S, Krumme D, Menge U, Plank-Schumacher K, Sztajer H, Wissing J, Wylegalla C, Hecht HJ. (2002) Tryparedoxin peroxidase of *Leishmania donovani*: molecular cloning, heterologous expression, specificity, and catalytic mechanism. *Arch. Biochem. Biophys.* 397:324-335.

Florencio FJ, Yee BC, Johnson TC, Buchanan BB. (1988) An NADP/thioredoxin system in leaves. Purification and characterization of NADP-thioredoxin reductase and thioredoxin h from spinach. *Arch. Biochem. Biophys.* 266:496-507.

Foloppe N, Sagemark J, Nordstrand K, Berndt KD, Nilsson L. (2001) Structure, dynamics and electrostatics of the active site of glutaredoxin 3 from *Escherichia coli* : comparison with functionally related proteins. *J. Mol. Biol.* 310:449-470.

Fortelle E, Bricogne G. (1997) Maximum-likelihood heavy-atom parameter refinement for multiple isomorphous replacement and multiwavelength anomalous diffraction methods. *Methods Enzymol.* 276:472-494.

Foyer CH, Rowell J, Walker D. (1983) Measurements of the ascorbate content of spinach leaf protoplasts and chloroplasts during illumination. *Planta* 157:239-244.

Foyer CH, Souriau N, Perret S, Lelandais M, Kunert KJ, Pruvost C, Jouanin L. (1995) Overexpression of glutathione reductase but not glutathione synthetase leads to increases in antioxidant capacity and resistance to photoinhibition in poplar trees. *Plant Physiol.* 109:1047-1057.

Foyer CH, Mullineaux PM. (1998) The presence of dehydroascorbate and dehydroascorbate reductase in plant tissues. *FEBS Lett.* 425:528-529.

Foyer CH, Noctor G. (2000) Oxygen processing in photosynthesis: regulation and signalling. *New Phytol.* 146:359-388.

Fra AM, Fagioli C, Finazzi D, Sitia R and Alberini C. (1993) Quality control of ER synthesized proteins: an exposed thiol group as a three-way switch mediating assembly, retention and degradation. *EMBO J* 12:4755-4761.

Frand AR, Cuozzo JW, Kaiser CA. (2000) Pathways for protein disulphide bond formation. *Trends Cell. Biol.* 10:203-210.

Fratelli M, Demol H, Puype M, Casagrande S, Eberini I, Salmona M, Bonetto V, Mengozzi M, Duffieux F, Miclet E, Bachi A, Vandekerckhove J, Gianazza E, Ghezzi P. (2002) Identification by redox proteomics of glutathionylated proteins in oxidatively stressed human T lymphocytes. *Proc. Natl. Acad. Sci. USA.* 99:3505-3510.

Frugoli JA, Zhong HH, Nuccio ML, McCourt P, McPeck MA, Thomas TL, McClung CR. (1996) Catalase is encoded by a multigene family in *Arabidopsis thaliana* (L.) Heynh. *Plant Physiol.* 112:327-336.

Fujii J, Ikeda Y. (2002) Advances in our understanding of peroxiredoxin, a multifunctional, mammalian redox protein. *Redox Rep.* 7:123-130.

## G

Gabbita SP, Aksenov MY, Lovell MA, Markesbery WR. (1999) Decrease in peptide methionine sulfoxide reductase in Alzheimer's disease brain. *J. Neurochem.* 73:1660-1666.

Garcia-Sanchez MI, Diaz-Quintana A, Gotor C, Jacquot JP, De la Rosa MA, Vega JM. (2000) Homology predicted structure and functional interaction of ferredoxin from the eukaryotic alga *Chlamydomonas reinhardtii* with nitrite reductase and glutamate synthase. *J. Biol. Inorg. Chem.* 5:713-719.



Garrido EO, Grant CM. (2002) Role of thioredoxins in the response of *Saccharomyces cerevisiae* to oxidative stress induced by hydroperoxides. *Mol. Microbiol.* 43:993-1003.

Gautier MF, Lullien-Pellerin V, de Lamotte-Guery F, Guirao A, Joudrier P. (1998) Characterization of wheat thioredoxin h cDNA and production of an active *Triticum aestivum* protein in *Escherichia coli*. *Eur. J. Biochem.* 252:314-324.

Gaymard E, Franchini L, Manieri W, Stutz E, Schurmann P. (2000) A dicistronic construct for the expression of functional spinach chloroplast ferredoxin:thioredoxin reductase in *Escherichia coli*. *Plant Sci.* 158:107-113.

Geck MK, Larimer FW, Hartman FC. (1996) Identification of residues of spinach thioredoxin f that influence interactions with target enzymes. *J. Biol. Chem.* 271:24736-24740.

Genot G, Wintz H, Houlné G, Jamet E. (2001) Molecular characterisation of a bean chloroplastic 2-Cys peroxiredoxin. *Plant Physiol. Biochem.* 39:449-459.

Gille G, Sigler K. (1995) Oxidative stress and living cells. *Folia Microbiol.* 40:131-152.

Gladyshev VN, Liu A, Novoselov SV, Krysan K, Sun QA, Kryukov VM, Kryukov GV, Lou MF. (2001) Identification and characterization of a new mammalian glutaredoxin (thioltransferase), Grx2. *J. Biol. Chem.* 276:30374-30380.

Gladyshev VN. (2002) Thioredoxin and peptide methionine sulfoxide reductase: convergence of similar structure and function in distinct structural folds. *Prot. Struct. Funct. Genetics* 46:149-152.

Gleason FK. (1996) Glucose-6-phosphate dehydrogenase from the cyanobacterium, *Anabaena* sp. PCC 7120: purification and kinetics of redox modulation. *Arch. Biochem. Biophys.* 334:277-283.

Goyer A, Haslekas C, Miginiac-Maslow M, Klein U, Le Marechal P, Jacquot JP, Decottignies P. (2002) Isolation and characterization of a thioredoxin-dependent peroxidase from *Chlamydomonas reinhardtii*. Eur. J. Biochem. 269:272-282.

Grant CM. (2001) Role of the glutathione/glutaredoxin and thioredoxin systems in yeast growth and response to stress conditions. Mol. Microbiol. 39:533-541.

Gravina SA, Mieyal JJ. (1993) Thioltransferase is a specific glutathionyl mixed disulfide oxidoreductase. Biochemistry 32:3368-3376.

Grimaud R, Ezraty B, Mitchell JK, Lafitte D, Briand C, Derrick PJ, Barras F. (2001) Repair of oxidized proteins. Identification of a new methionine sulfoxide reductase. J. Biol. Chem. 276:48915-48920.

Gustavsson N, Kokke BP, Harndahl U, Silow M, Bechtold U, Poghosyan Z, Murphy D, Boelens WC, Sundby C. (2002) A peptide methionine sulfoxide reductase highly expressed in photosynthetic tissue in *Arabidopsis thaliana* can protect the chaperone-like activity of a chloroplast-localized small heat shock protein. Plant J. 29:545-553.

## H

Haendeler J, Hoffmann J, Tischler V, Berk BC, Zeiher AM, Dimmeler S. (2002) Redox regulatory and anti-apoptotic functions of thioredoxin depend on S-nitrosylation at cysteine 69. Nat. Cell Biol. 4:743-749.

Halliwell B, Gutteridge JM. (1990) Role of free radicals and catalytic metal ions in human disease: an overview. Methods Enzymol. 186:1-85.

Hammad Y, Marechal J, Cournoyer B, Normand P, Domenach AM. (2001) Modification of the protein expression pattern induced in the nitrogen-fixing actinomycete *Frankia sp.* strain ACN14a-tsr by root exudates of its symbiotic host *Alnus glutinosa* and cloning of the *sodF* gene. Can. J. Microbiol. 47:541-547.

Hansel A, Kuschel L, Hehl S, Lemke C, Agricola HJ, Hoshi T, Heinemann SH. (2002) Mitochondrial targeting of the human peptide methionine sulfoxide reductase (MSRA), an enzyme involved in the repair of oxidized proteins. *FASEB J.* 16:911-913.

Haslekas C, Stacy RA, Nygaard V, Culianez-Macia FA, Aalen RB. (1998) The expression of a peroxiredoxin antioxidant gene, *AtPer1*, in *Arabidopsis thaliana* is seed-specific and related to dormancy. *Plant Mol. Biol.* 36:833-845.

Hassouni ME, Chambost JP, Expert D, Van Gijsegem F, Barras F. (1999) The minimal gene set member *msrA*, encoding peptide methionine sulfoxide reductase, is a virulence determinant of the plant pathogen *Erwinia chrysanthemi*. *Proc. Natl. Acad. Sci. USA* 96:887-892.

Henle ES, Linn S. (1997) Formation, prevention, and repair of DNA damage by iron/hydrogen peroxide. *J. Biol. Chem.* 272:19095-19098.

Herbette S, Lenne C, Leblanc N, Julien JL, Drevet JR, Roeckel-Drevet P. (2002) Two GPX-like proteins from *Lycopersicon esculentum* and *Helianthus annuus* are antioxidant enzymes with phospholipid hydroperoxide glutathione peroxidase and thioredoxin peroxidase activities. *Eur. J. Biochem.* 269:2414-2420.

Hillas PJ, del Alba FS, Oyarzabal J, Wilks A, Ortiz De Montellano PR. (2000) The AhpC and AhpD antioxidant defense system of *Mycobacterium tuberculosis*. *J. Biol. Chem.* 275:18801-18809.

Hirasawa M, Schurmann P, Jacquot JP, Manieri W, Jacquot P, Keryer E, Hartman FC, Knaff DB. (1999) Oxidation-reduction properties of chloroplast thioredoxins, ferredoxin:thioredoxin reductase, and thioredoxin f-regulated enzymes. *Biochemistry* 38:5200-5205.

Hirasawa M, Ruelland E, Schepens I, Issakidis-Bourguet E, Miginiac-Maslow M, Knaff DB. (2000) Oxidation-reduction properties of the regulatory disulfides of

sorghum chloroplast nicotinamide adenine dinucleotide phosphate-malate dehydrogenase. *Biochemistry* 39:3344-3350.

Hirel PH, Schmitter MJ, Dessen P, Fayat G, Blanquet S. (1989) Extent of N-terminal methionine excision from *Escherichia coli* proteins is governed by the side-chain length of the penultimate amino acid. *Proc. Natl. Acad. Sci. USA* 86:8247-8251.

Hirota K, Matsui M, Murata M, Takashima Y, Cheng FS, Itoh T, Fukuda K, Yodoi J. (2000) Nucleoredoxin, glutaredoxin, and thioredoxin differentially regulate NF-kappaB, AP-1, and CREB activation in HEK293 cells. *Biochem. Biophys. Res. Commun.* 274:177-182.

Hirotsu S, Abe Y, Okada K, Nagahara N, Hori H, Nishino T, Hakoshima T. (1999) Crystal structure of a multifunctional 2-Cys peroxiredoxin heme-binding protein 23 kDa/proliferation-associated gene product. *Proc. Natl. Acad. Sci. USA* 96:12333-12338.

Hodges M, Miginiac-Maslow M, Decottignies P, Jacquot JP, Stein M, Lepiniec L, Crétin C, Gadal P. (1994) Purification and characterization of pea thioredoxin *f* expressed in *Escherichia coli*. *Plant Mol. Biol.* 26:225-234.

Hofmann B, Hecht HJ, Flohe L. (2002) Peroxiredoxins. *Biol. Chem.* 383:347-364.

Holmgren A. (1968) Thioredoxin. The amino acid sequence of the protein from *Escherichia coli*. *Eur. J. Biochem.* 6:475-484.

Holmgren A. (1979) Reduction of disulfides by thioredoxin. Exceptional reactivity of insulin and suggested functions of thioredoxin in mechanism of hormone action. *J. Biol. Chem.* 254:9627-9632.

Holmgren A. (1979) Glutathione-dependent synthesis of deoxyribonucleotides. Purification and characterization of glutaredoxin from *Escherichia coli*. *J. Biol. Chem.* 254:3664-3671.

Holmgren A. (1989) Thioredoxin and glutaredoxin systems. J. Biol. Chem. 264:13963-13966.

Holmgren A, Aslund F. (1995) Glutaredoxin. Methods Enzymol. 252:283-292.

Holmgren A. (2000) Antioxidant function of thioredoxin and glutaredoxin systems. Antioxid. Redox Signal. 2:811-820.

Horling F, Baier M, Dietz KJ. (2001) Redox-regulation of the expression of the peroxide-detoxifying chloroplast 2-cys peroxiredoxin in the liverwort *Riccia fluitans*. Planta 214:304-313.

Horling F, König J, Dietz KJ. (2002) Type II peroxiredoxin C, a member of the peroxiredoxin family of *Arabidopsis thaliana*: its expression and activity in comparison with other peroxiredoxins. Plant Physiol. Biochem. 40:491-499.

Horling F, Lamkemeyer P, König J, Finkemeier I, Kandlbinder A, Baier M, Dietz KJ. (2003) Divergent light-, ascorbate-, and oxidative stress-dependent regulation of expression of the peroxiredoxin gene family in *Arabidopsis*. Plant Physiol. 131:317-325.

Huang Y, Domann FE. (1998) Redox modulation of AP-2 DNA binding activity *in vitro*. Biochem. Biophys. Res. Commun. 249:307-312.

Huber HE, Russel M, Model P, Richardson CC. (1986) Interaction of mutant thioredoxins of *Escherichia coli* with the gene 5 protein of phage T7. The redox capacity of thioredoxin is not required for stimulation of DNA polymerase activity. J. Biol. Chem. 261:15006-15012.

Huber-Wunderlich M, Glockshuber R. (1998) A single dipeptide sequence modulates the redox properties of a whole enzyme family. Fold Des. 3:161-171.

Hurley JK, Hazzard JT, Martinez-Julvez M, Medina M, Gomez-Moreno C, Tollin G. (1999) Electrostatic forces involved in orienting *Anabaena* ferredoxin during binding

to *Anabaena* ferredoxin : NADP<sup>+</sup> reductase : site-specific mutagenesis, transient kinetic measurements, and electrostatic surface potentials. *Protein Sci.* 8:1614-1622.

## I

Isakov N, Witte S, Altman A. (2000) PICOT-HD: a highly conserved protein domain that is often associated with thioredoxin and glutaredoxin modules. *Trends Biochem. Sci.* 25:537-539.

Ishiwatari Y, Honda C, Kawashima I, Nakamura S, Hirano H, Mori S, Fujiwara T, Hayashi H, Chino M. (1995) Thioredoxin h is one of the major proteins in rice phloem sap. *Planta* 195:456-463.

Ishiwatari Y, Fujiwara T, McFarland KC, Nemoto K, Hayashi H, Chino M, Lucas WJ. (1998) Rice phloem thioredoxin h has the capacity to mediate its own cell-to-cell transport through plasmodesmata. *Planta* 205:12-22.

Issakidis E, Lemaire M, Decottignies P, Jacquot JP, Miginiac-Maslow M. (1996) Direct evidence for the different roles of the N- and C-terminal regulatory disulfides of sorghum leaf NADP-malate dehydrogenase in its activation by reduced thioredoxin. *FEBS Lett.* 392:121-124.

Issakidis-Bourguet E, Mouaheb N, Meyer Y, Miginiac-Maslow M. (2001) Heterologous complementation of yeast reveals a new putative function for chloroplast m-type thioredoxin. *Plant J.* 25:127-135.

## J

Jacquot JP, Gadal P, Nishizawa AN, Yee BC, Crawford NA, Buchanan BB. (1984) Enzyme regulation in C4 photosynthesis: mechanism of activation of NADP-malate dehydrogenase by reduced thioredoxin. *Arch. Biochem. Biophys.* 228:170-178.

Jacquot JP, de Lamotte F, Fontecave M, Schurmann P, Decottignies P, Miginiac-Maslow M, Wollman E. (1990) Human thioredoxin reactivity-structure/function relationship. *Biochem. Biophys. Res. Commun.* 173:1375-1381.

Jacquot JP, Keryer E, Issakidis E, Decottignies P, Miginiac-Maslow M, Schmitter JM, Crépin C. (1991) Properties of recombinant NADP-malate dehydrogenases from *Sorghum vulgare* leaves expressed in *Escherichia coli*. *Eur. J. Biochem.* 199:47-51.

Jacquot JP, Rivera-Madrid R, Marinho P, Kollarova M, Le Marechal P, Miginiac-Maslow M, Meyer Y. (1994) *Arabidopsis thaliana* NADPH thioredoxin reductase. cDNA characterization and expression of the recombinant protein in *Escherichia coli*. *J. Mol. Biol.* 235:1357-1363.

Jacquot JP, Issakidis E, Decottignies P, Lemaire M, Miginiac-Maslow. (1995a) Analysis and manipulation of target enzymes for thioredoxin control. *Methods Enzymol.* 252:240-252.

Jacquot JP, Lopez-Jaramillo J, Chueca A, Cherfils J, Lemaire S, Chedozeau B, Miginiac-Maslow M, Decottignies P, Wolosiuk R, Lopez-Gorge J. (1995b) High-level expression of recombinant pea chloroplast fructose-1,6-bisphosphatase and mutagenesis of its regulatory site. *Eur. J. Biochem.* 229:675-681.

Jacquot JP, Lancelin JM, Meyer Y. (1997) Thioredoxins: Structure and function in plant cells. *New Phytol.* 136:543-570.

Jacquot JP, Lopez-Jaramillo J, Miginiac-Maslow M, Lemaire S, Cherfils J, Chueca A, Lopez-Gorge J. (1997) Cysteine-153 is required for redox regulation of pea chloroplast fructose-1,6-bisphosphatase. *FEBS Lett.* 401:143-147.

Jacquot JP, Stein M, Suzuki A, Liottet S, Sandoz G, Miginiac-Maslow M. (1997) Residue Glu-91 of *Chlamydomonas reinhardtii* ferredoxin is essential for electron transfer to ferredoxin-thioredoxin reductase. *FEBS Lett.* 400:293-296.

Jancarik J, Kim SH. (1991) Sparse matrix sampling : a screening method for crystallization of proteins. *J. Appl. Cryst.* 24:409-411.

Jeng MF, Campbell AP, Begley T, Holmgren A, Case DA, Wright PE, Dyson HJ. (1994) High-resolution solution of oxidized and reduced *Escherichia coli* thioredoxin. *Structure* 2: 853-868.

Jeong W, Cha MK, Kim IH. (2000) Thioredoxin-dependent hydroperoxide peroxidase activity of bacterioferritin comigratory protein (BCP) as a new member of the thiol-specific antioxidant protein (TSA)/Alkyl hydroperoxide peroxidase C (AhpC) family. *J. Biol. Chem.* 275:2924-2930.

Jiao JA, Yee BC, Kobrehel K, Buchanan BB. (1992) Effect of thioredoxin-linked reduction on the activity and stability of the Kunitz and Bowman-Birk soybean trypsin-inhibitor proteins. *J. Agric. Food Chem.* 40:2333-2336.

Jiao JA, Yee BC, Wong JH, Kobrehel K, Buchanan BB. (1993) Thioredoxin-linked changes in regulatory properties of barley  $\alpha$ -amylase/subtilisin inhibitor protein. *Plant Physiol. Biochem.* 31:799-804.

Jin DY, Chae HZ, Rhee SG, Jeang KT. (1997) Regulatory role for a novel human thioredoxin peroxidase in NF-kappaB activation. *J. Biol. Chem.* 272:30952-30961.

Johansson K, Ramaswamy S, Saarinen M, Lemaire-Chamley M, Issakidis-Bourguet E, Miginiac-Maslow M, Eklund H. (1999) Structural basis for light activation of a chloroplast enzyme : the structure of sorghum NADP-malate dehydrogenase in its oxidized form. *Biochemistry* 38:4319-4326.

Joo JH, Bae YS, Lee JS. (2001) Role of auxin-induced reactive oxygen species in root gravitropism. *Plant Physiol.* 126:1055-1060.

Jung BG, Lee KO, Lee SS, Chi YH, Jang HH, Kang SS, Lee K, Lim D, Yoon SC, Yun DJ, Inoue Y, Cho MJ, Lee SY. (2002a) A *Chinese cabbage* cDNA with high



sequence identity to phospholipid hydroperoxide glutathione peroxidases encodes a novel isoform of thioredoxin-dependent peroxidase. *J. Biol. Chem.* 277:12572-12578.

Jung S, Hansel A, Kasperczyk H, Hoshi T, Heinemann SH. (2002b) Activity, tissue distribution and site directed mutagenesis of a human peptide methionine sulfoxide reductase of type B: hCBS1. *FEBS Lett.* 527:91-94.

## K

Kang SW, Baines IC, Rhee SG. (1998) Characterization of a mammalian peroxiredoxin that contains one conserved cysteine. *J. Biol. Chem.* 273:6303-6311.

Kang SW, Chae HZ, Seo MS, Kim K, Baines IC, Rhee SG. (1998) Mammalian peroxiredoxin isoforms can reduce hydrogen peroxide generated in response to growth factors and tumor necrosis factor-alpha. *J. Biol. Chem.* 273:6297-6302.

Kanzok SM, Fechner A, Bauer H, Ulschmid JK, Muller HM, Botella-Munoz J, Schneuwly S, Schirmer R, Becker K. (2001) Substitution of the thioredoxin system for glutathione reductase in *Drosophila melanogaster*. *Science* 291:643-646.

Kanzok SM, Schirmer RH, Turbachova I, Iozef R, Becker K. (2000) The thioredoxin system of the malaria parasite *Plasmodium falciparum*. Glutathione reduction revisited. *J. Biol. Chem.* 275:40180-40186.

Katti SK, Lemaster DM, Eklund H. (1990) Crystal structure of thioredoxin from *Escherichia coli* at 1.68 Å resolution. *J. Mol. Biol.* 212:167-184.

Katti SK, Robbins AH, Yang Y, Wells WW. (1995) Crystal structure of thioltransferase at 2.2 Å resolution. *Protein Sci.* 4:1998-2005.

Kemmink J, Darby NJ, Dijkstra K, Nilges M, Creighton TE. (1997) The folding catalyst protein disulfide isomerase is constructed of active and inactive thioredoxin modules. *Curr. Biol.* 7:239-245.

Kim H, Lee TH, Park ES, Suh JM, Park SJ, Chung HK, Kwon OY, Kim YK, Ro HK, Shong M. (2000) Role of peroxiredoxins in regulating intracellular hydrogen peroxide and hydrogen peroxide-induced apoptosis in thyroid cells. *J. Biol. Chem.* 275:18266-18270.

Kim HT, Russell RL, Raina AK, Harris PL, Siedlak SL, Zhu X, Petersen RB, Shimohama S, Smith MA, Perry G. (2000) Protein disulfide isomerase in Alzheimer disease. *Antioxid. Redox Signal.* 2:485-489.

Kim SJ, Woo JR, Hwang YS, Jeong DG, Shin DH, Kim K, Ryu SE. (2003) The tetrameric structure of *Haemophilus influenzae* hybrid Prx5 reveals interactions between electron donor and acceptor proteins. *J. Biol. Chem.* 278:10790-10798.

Klatt P, Lamas S. (2000) Regulation of protein function by S-glutathiolation in response to oxidative and nitrosative stress. *Eur. J. Biochem.* 267:4928-4944.

Kleczkowski LA, Randall DD. (1985) Light and thiol activation of maize leaf glycerate kinase. The stimulating effect of reduced thioredoxins and ATP. *Plant Physiol.* 79:274-277.

Klughammer B, Baier M, Dietz KJ. (1998) Inactivation by gene disruption of 2-cysteine-peroxiredoxin in *Synechocystis* sp. PCC 6803 leads to increased stress sensitivity. *Physiol. Plant.* 104:699-706.

Knaff DB, Hirasawa M. (1991) Ferredoxin-dependent chloroplast enzymes. *Biochim. Biophys. Acta.* 1056:93-125.

Knoblauch M, Van Bel AJE. (1998) Sieve tubes in action. *Plant Cell* 10:35-50.

Knoops B, Clippe A, Bogard C, Arsalane K, Wattiez R, Hermans C, Duconseille E, Falmagne P, Bernard A. (1999) Cloning and characterization of AOEB166, a novel mammalian antioxidant enzyme of the peroxiredoxin family. *J. Biol. Chem.* 274:30451-30458.

Kobrehel K, Yee BC, Buchanan BB. (1991) Role of the NADP/thioredoxin system in the reduction of alpha-amylase and trypsin inhibitor proteins. *J. Biol. Chem.* 266:16135-16140.

Kobrehel K, Wong JH, Balogh A, Kiss F, Yee BC, Buchanan BB. (1992) Specific reduction of wheat storage proteins by thioredoxin h. *Plant Physiol.* 99:919-924.

Köhler B, Hills A, Blatt MR. (2003) Control of guard cell ion channels by hydrogen peroxide and abscisic acid indicates their action through alternate signaling pathways. *Plant Physiol.* 131:385-388.

Kong W, Shiota S, Shi Y, Nakayama H, Nakayama K. (2000) A novel peroxiredoxin of the plant *Sedum lineare* is a homologue of *Escherichia coli* bacterioferritin co-migratory protein (Bcp). *Biochem. J.* 351:107-114.

König J, Baier M, Horling F, Kahmann U, Harris G, Schurmann P, Dietz KJ. (2002) The plant-specific function of 2-Cys peroxiredoxin-mediated detoxification of peroxides in the redox-hierarchy of photosynthetic electron flux. *Proc. Natl. Acad. Sci. USA* 99:5738-5743.

König J, Lotte K, Plessow R, Brockhinke A, Baier M, Dietz KJ. (2003) Reaction mechanism of plant 2-Cys peroxiredoxin: Role of the C-terminus and the quaternary structure. *J. Biol. Chem.* In press.

Koprivova A, Meyer AJ, Schween G, Herschbach C, Reski R, Kopriva S. (2002) functional knockout of the adenosine 5'-phosphosulfate reductase gene in *Physcomitrella patens* revives an old route of sulfate assimilation. *J. Biol. Chem.* 277:32195-32201.

Kortemme T, Creighton TE. (1995) Ionisation of cysteine residues at the termini of model alpha-helical peptides. Relevance to unusual thiol pKa values in proteins of the thioredoxin family. *J. Mol. Biol.* 253:799-812.

Kovtun Y, Chiu WL, Tena G, Sheen J. (2000) Functional analysis of oxidative stress-activated mitogen-activated protein kinase cascade in plants. *Proc. Natl. Acad. Sci. USA* 97:2940-2945.

Kowaltowski AJ, Vercesi AE, Rhee SG, Netto LE. (2000) Catalases and thioredoxin peroxidase protect *Saccharomyces cerevisiae* against  $Ca^{2+}$ -induced mitochondrial membrane permeabilization and cell death. *FEBS Lett.* 473:177-182.

Krause G, Holmgren A. (1991) Substitution of the conserved tryptophan 31 in *Escherichia coli* thioredoxin by site-directed mutagenesis and structure-function analysis. *J. Biol. Chem.* 266:4056-4066.

Krimm I, Lemaire S, Ruelland E, Miginiac-Maslow M, Jaquot JP, Hirasawa M, Knaff DB, Lancelin JM. (1998) The single mutation Trp35-->Ala in the 35-40 redox site of *Chlamydomonas reinhardtii* thioredoxin h affects its biochemical activity and the pH dependence of C36-C39  $^1H$ - $^{13}C$  NMR. *Eur. J. Biochem.* 255:185-195.

Kryukov GV, Kumar RA, Koc A, Sun Z, Gladyshev VN. (2002) Selenoprotein R is a zinc-containing stereo-specific methionine sulfoxide reductase. *Proc. Natl. Acad. Sci. USA* 99:4245-4250.

Kuge S, Arita M, Murayama A, Maeta K, Izawa S, Inoue Y, Nomoto A. Regulation of the yeast Yap1p nuclear export signal is mediated by redox signal-induced reversible disulfide bond formation. *Mol. Cell. Biol.* 21:6139-6150.

Kumar RA, Koc A, Cerny RL, Gladyshev VN. (2002) Reaction mechanism, evolutionary analysis, and role of zinc in *Drosophila* methionine-R-sulfoxide reductase. *J. Biol. Chem.* 277:37527-37535.

Kuschel L, Hansel A, Schonherr R, Weissbach H, Brot N, Hoshi T, Heinemann SH. (1999) Molecular cloning and functional expression of a human peptide methionine sulfoxide reductase (hMsrA). *FEBS Lett.* 456:17-21.

L

Laemmli UK. (1970) Cleavage of structural proteins during the assembly of the head of bacteriophage T4. *Nature* 227:680-685.

Laloi C, Rayapuram N, Chartier Y, Grienenberger JM, Bonnard G, Meyer Y. (2001) Identification and characterization of a mitochondrial thioredoxin system in plants. *Proc. Natl. Acad. Sci. USA* 98:14144-14149.

de Lamotte-Guery F, Miginiac-Maslow M, Decottignies P, Stein M, Minard P, Jacquot JP. (1991) Mutation of a negatively charged amino acid in thioredoxin modifies its reactivity with chloroplastic enzymes. *Eur. J. Biochem.* 196:287-294.

Lancelin JM, Stein M, Jacquot JP. (1993) Secondary structure and protein folding of recombinant chloroplastic thioredoxin Ch2 from the green alga *Chlamydomonas reinhardtii* as determined by <sup>1</sup>H NMR. *J. Biochem.* 114:421-431.

Lancelin JM, Guilhaudis L, Krimm I, Blackledge MJ, Marion D, Jacquot JP. (2000) NMR structures of thioredoxin m from the green alga *Chlamydomonas reinhardtii*. *Prot. Struct. Funct. Genetics* 41:334-349.

Laplace JM, Hartke A, Giard JC, Auffray Y. (2000) Cloning, characterization and expression of an *Enterococcus faecalis* gene responsive to heavy metals. *Appl. Microbiol. Biotechnol.* 53:685-689.

Laughner BJ, Sehnke PC, Ferl RJ. (1998) A novel nuclear member of the thioredoxin superfamily. *Plant Physiol.* 118:987-996.

Lee KO, Jang HH, Jung BG, Chi YH, Lee JY, Choi YO, Lee JR, Lim CO, Cho MJ, Lee SY. (2000) Rice 1Cys-peroxiredoxin over-expressed in transgenic tobacco does not maintain dormancy but enhances antioxidant activity. *FEBS Lett.* 486:103-106.

Lee KO, Lee JR, Yoo JY, Jang HH, Moon JC, Jung BG, Chi YH, Park SK, Lee SS, Lim CO, Yun DJ, Cho MJ, Lee SY. (2002) GSH-dependent peroxidase activity of the

rice (*Oryza sativa*) glutaredoxin, a thioltransferase. *Biochem. Biophys. Res. Commun.* 296:1152-1156.

Lee SP, Hwang YS, Kim YJ, Kwon KS, Kim HJ, Kim K, Chae HZ. (2001) Cyclophilin a binds to peroxiredoxins and activates its peroxidase activity. *J. Biol. Chem.* 276:29826-29832.

Lee TH, Yu SL, Kim SU, Kim YM, Choi I, Kang SW, Rhee SG, Yu DY. (1999) Characterization of the murine gene encoding 1-Cys peroxiredoxin and identification of highly homologous genes. *Gene* 234:337-344.

Lemaire S, Keryer E, Stein M, Schepens I, Issakidis-Bourguet E, Gerard-Hirne C, Miginiac-Maslow M, Jacquot JP. (1999) Heavy-metal regulation of thioredoxin gene expression in *Chlamydomonas reinhardtii*. *Plant Physiol.* 120:773-778.

Lemaire SD, Richardson JM, Goyer A, Keryer E, Lancelin JM, Makhatadze GI, Jacquot JP. (2000) Primary structure determinants of the pH- and temperature-dependent aggregation of thioredoxin. *Biochim. Biophys. Acta.* 1476:311-323.

Lemaire S, Collin V, Keryer E, Issakidis-Bourguet E, Lavergne D, Miginiac-Maslow M. (2003) *Chlamydomonas reinhardtii*: a model for the study of the thioredoxin family. *Plant Physiol. Biochem.* In press.

Levine A, Tenhaken R, Dixon R, Lamb C. (1994) H<sub>2</sub>O<sub>2</sub> from the oxidative burst orchestrates the plant hypersensitive disease resistance response. *Cell* 79:583-593.

Levine RL, Berlett BS, Moskovitz J, Mosoni L, Stadtman ER. (1999) Methionine residues may protect proteins from critical oxidative damage. *Mech. Ageing Dev.* 107:323-332.

Levine RL, Moskovitz J, Stadtman ER. (2000) Oxidation of methionine in proteins: roles in antioxidant defense and cellular regulation. *IUBMB Life* 50:301-307.

Lewis ML, Miki K, Ueda T. (2000) FePer 1, a gene encoding an evolutionarily conserved 1-Cys peroxiredoxin in buckwheat (*Fagopyrum esculentum* Moench), is expressed in a seed-specific manner and induced during seed germination. *Gene* 246:81-91.

Li D, Stevens FJ, Schiffer M, Anderson LE. (1994) Mechanism of light modulation: identification of potential redox-sensitive cysteines distal to catalytic site in light-activated chloroplast enzymes. *Biophys. J.* 67:29-35.

Lichter A, Häberlein I. (1998) A light-dependent redox signal participates in the regulation of ammonia fixation in chloroplasts of higher plants-ferredoxin : glutamate synthase is a thioredoxin-dependent enzyme. *J. Plant Physiol.* 153:83-90.

Liebler DC, Kling DS, Reed DJ. (1986) Antioxidant protection of phospholipid bilayers by alpha-tocopherol. Control of alpha-tocopherol status and lipid peroxidation by ascorbic acid and glutathione. *J. Biol. Chem.* 261:12114-12119.

Lillig CH, Prior A, Schwenn JD, Aslund F, Ritz D, Vlamis-Gardikas A, Holmgren A. (1999) New thioredoxins and glutaredoxins as electron donors of 3'-phosphoadenylylsulfate reductase. *J. Biol. Chem.* 274:7695-7698.

Lillig CH, Potamitou A, Schwenn JD, Vlamis-Gardikas A, Holmgren A. (2003) Redox regulation of 3' phosphoadenylylsulfate reductase from *Escherichia coli* by glutathione and glutaredoxins. *J. Biol. Chem.* Sous presse.

Lind C, Gerdes R, Schuppe-Koistinen I, Cotgreave IA. (1998) Studies on the mechanism of oxidative modification of human glyceraldehyde-3-phosphate dehydrogenase by glutathione : catalysis by glutaredoxin. *Biochem. Biophys. Res. Commun.* 247:481-486.

Looman AC, Bodlaender J, Comstock LJ, Eaton D, Jhurani P, de Boer HA, van Knippenberg PH. (1987) Influence of the codon following the AUG initiation codon on the expression of a modified *lacZ* gene in *Escherichia coli*. *EMBO J.* 6:2489-2492.

Lowther WT, Brot N, Weissbach H, Matthews BW. (2000) Structure and mechanism of peptide methionine sulfoxide reductase, an "anti-oxidation" enzyme. *Biochemistry* 39:13307-13312.

Lowther WT, Weissbach H, Etienne F, Brot N, Matthews BW. (2002) The mirrored methionine sulfoxide reductases of *Neisseria gonorrhoeae* pilB. *Nat. Struct. Biol.* 9:348-352.

Luikenhuis S, Perrone G, Dawes IW, Grant CM. (1998) The yeast *Saccharomyces cerevisiae* contains two glutaredoxin genes that are required for protection against reactive oxygen species. *Mol. Biol. Cell.* 9:1081-1091.

Lundberg M, Johansson C, Chandra J, Enoksson M, Jacobsson G, Ljung J, Johansson M, Holmgren A. (2001) Cloning and expression of a novel human glutaredoxin (Grx2) with mitochondrial and nuclear isoforms. *J. Biol. Chem.* 276:26269-26275.

Lundstrom J, Krause G, Holmgren A. (1992) A Pro to His mutation in active site of thioredoxin increases its disulfide-isomerase activity 10-fold. New refolding systems for reduced or randomly oxidized ribonuclease. *J. Biol. Chem.* 267:9047-9052.

Lundstrom-Ljung J, Vlamis-Gardikas A, Aslund F, Holmgren A. (1999) Reactivity of glutaredoxins 1, 2 and 3 from *Escherichia coli* and protein disulfide isomerase towards glutathionyl-mixed disulfides in ribonuclease A. *FEBS Lett.* 443:85-88.

Luthman M, Eriksson S, Holmgren A, and Thelander L. (1979) Glutathione-dependent hydrogen donor system for calf thymus ribonucleoside-diphosphate reductase. *Proc. Natl. Acad. Sci. USA* 76:2158-2162.

## M

Makrides SC. (1996) Strategies for achieving high-level expression of genes in *Escherichia coli*. *Microbiol. Rev.* 60:512-538.



Maiorino M, Gregolin C, Ursini F. (1990) Phospholipid hydroperoxide glutathione peroxidase. *Methods Enzymol.* 186:448-457.

Manevich Y, Sweitzer T, Pak JH, Feinstein SI, Muzykantov V, Fisher AB. (2002) 1-Cys peroxiredoxin overexpression protects cells against phospholipid peroxidation-mediated membrane damage. *Proc. Natl. Acad. Sci. USA* 99:11599-11604.

Marcotte EM, Pellegrini M, Ng HL, Rice DW, Yeates TO, Eisenberg D. (1999) Detecting protein function and protein-protein interactions from genome sequences. *Science* 285:751-753.

Martinez-Julvez M, Nogues I, Faro M, Hurley JK, Brodie TB, Mayoral T, Sanz-Aparicio J, Hermoso JA, Stankovich MT, Medina M, Tollin G, Gomez-Moreno C. (2001) Role of a cluster of hydrophobic residues near the FAD cofactor in *Anabaena* PCC 7119 ferredoxin-NADP<sup>+</sup> reductase for optimal complex formation and electron transfer to ferredoxin. *J. Biol. Chem.* 276:27498-27510.

Marx C, Wong JH, Buchanan BB. (2003) Thioredoxin and germinating barley: targets and protein redox changes. *Planta* 216:454-460.

Matthews BW. (1968) Solvent content of protein crystals. *J. Mol. Biol.* 33:491-497.

McIndoe RA, Linhardt S, Hood L. (1995) Improved high level expression system for eukaryotic genes in *Escherichia coli* using T7 RNA polymerase and rare Arg tRNAs. *Biotechniques* 19:196-200.

McPherson A. (1999) Crystallisation of biological macromolecules. Cold Spring Harbor Laboratory Press.

Meinhard M, Grill E. (2001) Hydrogen peroxide is a regulator of ABI1, a protein phosphatase 2C from *Arabidopsis*. *FEBS Lett.* 508:443-446.

Menand B, Marechal-Drouard L, Sakamoto W, Dietrich A, Wintz H. (1998) A single gene of chloroplast origin codes for mitochondrial and chloroplastic methionyl-tRNA synthetase in *Arabidopsis thaliana*. Proc. Natl. Acad. Sci. USA 95:11014-11019.

Menchise V, Corbier C, Didierjean C, Jacquot JP, Benedetti E, Aubry A, Saviano M. (2000) Crystal structure of the W35A mutant thioredoxin h of *Chlamydomonas reinhardtii*: the substitution of the conserved active site Trp leads to modifications in the environment of the two catalytic cysteines. Biopolymers 56:1-7.

Menchise V, Corbier C, Didierjean C, Saviano M, Benedetti E, Jacquot JP, Aubry A. (2001) Crystal structure of the wild-type and D30A mutant thioredoxin h of *Chlamydomonas reinhardtii* and implications for the catalytic mechanism. Biochem. J. 359:65-75.

Mendgen K, Hahn M. (2002) Plant infection and the establishment of fungal biotrophy. Trends Plant Sci. 7:352-356.

Meyer Y, Verdoucq L, Vignols F. (1999) Plant thioredoxins and glutaredoxins: identity and putative roles. Trends Plant Sci. 4:388-394.

Meyer Y, Vignols F, Reichheld JP. (2002) Classification of plant thioredoxins by sequence similarity and intron position. Methods Enzymol. 347:394-402.

Mestres-Ortega D, Meyer Y. (1999) The *Arabidopsis thaliana* genome encodes at least four thioredoxins m and a new prokaryotic-like thioredoxin. Gene 240:307-316.

Miginiac-Maslow M, Decottignies P, Jacquot JP, Gadal P. (1990) Regulation of corn leaf NADP-Malate dehydrogenase light-activation by the photosynthetic electron flow. Effect of photoinhibition studied in a reconstituted system. Biochim. Biophys. Acta 1017:273-279.

Miginiac-Maslow M, Johansson K, Ruelland E, Issakidis-Bourguet E, Schepens I, Goyer A, Lemaire-Chamley M, Jacquot JP, Le Maréchal P, Decottignies P. (2000)

Light activation of NADP-malate dehydrogenase : a highly controlled process for an optimized function. *Physiol. Plant.* 110:322-329.

Miki J, Maeda M, Mukohata Y, Futai M. (1988) The gamma-subunit of ATP synthase from spinach chloroplasts. Primary structure deduced from the cloned cDNA sequence. *FEBS Lett.* 232:221-226.

Milanez S, Mural RJ, Hartman FC. (1991) Roles of cysteinyl residues of phosphoribulokinase as examined by site-directed mutagenesis. *J. Biol. Chem.* 266:10694-10699.

Minakuchi K, Yabushita T, Masumura T, Ichihara K, Tanaka K. (1994) Cloning and sequence analysis of a cDNA encoding rice glutaredoxin. *FEBS Lett.* 337:157-160.

Mintz KP, Moskovitz J, Wu H, Fives-Taylor PM. (2002) Peptide methionine sulfoxide reductase (MsrA) is not a major virulence determinant for the oral pathogen *Actinobacillus actinomycetemcomitans*. *Microbiology* 148:3695-3703.

Miot S, Frey P, Pinon J. (1999) Varietal mixture of poplar clones: Effects on infection by *Melampsora larici-populina* and on plant growth. *Eur. J. Forest Pathol.* 29:411-423.

Miranda-Vizueté A, Damdimopoulos AE, Spyrou G. (2000) The mitochondrial thioredoxin system. *Antioxid. Redox Signal.* 2:801-810.

Mittard V, Blackledge MJ, Stein M, Jacquot JP, Marion D, Lancelin JM. (1997) NMR solution structure of an oxidised thioredoxin h from the eukaryotic alga *Chlamydomonas reinhardtii*. *Eur. J. Biochem.* 243:674-678.

Montemartini M, Nogoceke E, Singh M, Steinert P, Flohe L, Kalisz HM. (1998) Sequence analysis of the trypanothione peroxidase gene from *Crithidia fasciculata* and its functional expression in *Escherichia coli*. *J. Biol. Chem.* 273:4864-4871.

Montemartini M, Kalisz HM, Hecht HJ, Steinert P, Flohe L. (1999) Activation of active-site cysteine residues in the peroxiredoxin-type trypanothione peroxidase of *Crithidia fasciculata*. Eur. J. Biochem. 264:516-524.

Morell S, Follmann H, Haberlein I. (1995) Identification and localization of the first glutaredoxin in leaves of a higher plant. FEBS Lett. 369:149-152.

Moskovitz J, Rahman MA, Strassman J, Yancey SO, Kushner SR, Brot N, Weissbach H. (1995) *Escherichia coli* peptide methionine sulfoxide reductase gene : regulation of expression and role in protecting against oxidative damage. J. Bacteriol. 177:502-507.

Moskovitz J, Weissbach H, Brot N. (1996a) Cloning and expression of a mammalian gene involved in the reduction of methionine sulfoxide residues in proteins. Proc. Natl. Acad. Sci. USA 93:2095-2099.

Moskovitz J, Jenkins NA, Gilbert DJ, Copeland NG, Jursky F, Weissbach H, Brot N. (1996b) Chromosomal localization of the mammalian peptide-methionine sulfoxide reductase gene and its differential expression in various tissues. Proc. Natl. Acad. Sci. USA 93:3205-3208.

Moskovitz J, Berlett BS, Poston JM, Stadtman ER. (1997) The yeast peptide-methionine sulfoxide reductase functions as an antioxidant *in vivo*. Proc. Natl. Acad. Sci. USA 94:9585-9589.

Moskovitz J, Flescher E, Berlett BS, Azare J, Poston JM, Stadtman ER. (1998) Overexpression of peptide-methionine sulfoxide reductase in *Saccharomyces cerevisiae* and human T cells provides them with high resistance to oxidative stress. Proc. Natl. Acad. Sci. USA 95:14071-14075.

Moskovitz J, Berlett BS, Poston JM, Stadtman ER. (1999) Methionine sulfoxide reductase in antioxidant defense. Methods Enzymol. 300:239-244.

Moskovitz J, Poston JM, Berlett BS, Nosworthy NJ, Szczepanowski R, Stadtman ER. (2000) Identification and characterization of a putative active site for peptide methionine sulfoxide reductase (MsrA) and its substrate stereospecificity. *J. Biol. Chem.* 275:14167-14172.

Moskovitz J, Bar-Noy S, Williams WM, Requena J, Berlett BS, Stadtman ER. (2001) Methionine sulfoxide reductase (MsrA) is a regulator of antioxidant defense and lifespan in mammals. *Proc. Natl. Acad. Sci. USA* 98:12920-12925.

Moskovitz J, Singh VK, Requena J, Wilkinson BJ, Jayaswal RK, Stadtman ER. (2002) Purification and characterization of methionine sulfoxide reductases from mouse and *Staphylococcus aureus* and their substrate stereospecificity. *Biochem. Biophys. Res. Commun.* 290:62-65.

Mossner E, Huber-Wunderlich M, Glockshuber R. (1998) Characterization of *Escherichia coli* thioredoxin variants mimicking the active-sites of other thiol/disulfide oxidoreductases. *Protein Sci.* 7:1233-1244.

Mossner E, Huber-Wunderlich M, Rietsch A, Beckwith J, Glockshuber R, Aslund F. (1999) Importance of redox potential for the *in vivo* function of the cytoplasmic disulfide reductant thioredoxin from *Escherichia coli*. *J. Biol. Chem.* 274:25254-25259.

Motohashi K, Kondoh A, Stumpp MT, Hisabori T. (2001) Comprehensive survey of proteins targeted by chloroplast thioredoxin. *Proc. Natl. Acad. Sci. USA* 98:11224-11229.

Mouaheb N, Thomas D, Verdoucq L, Monfort P, Meyer Y. (1998) *In vivo* functional discrimination between plant thioredoxins by heterologous expression in the yeast *Saccharomyces cerevisiae*. *Proc. Natl. Acad. Sci. USA* 95:3312-3317.

Mowla SB, Thomson JA, Farrant JM, Mundree SG. (2002) A novel stress-inducible antioxidant enzyme identified from the resurrection plant *Xerophyta viscosa* Baker. *Planta* 215:716-726.

Mullineaux PM, Karpinski S, Jimenez A, Cleary SP, Robinson C, Creissen GP. (1998) Identification of cDNAs encoding plastid-targeted glutathione peroxidase. *Plant J.* 13:375-379.

Murata Y, Pei ZM, Mori IC, Schroeder J. (2001) Abscisic acid activation of plasma membrane Ca(2+) channels in guard cells requires cytosolic NAD(P)H and is differentially disrupted upstream and downstream of reactive oxygen species production in *abi1-1* and *abi2-1* protein phosphatase 2C mutants. *Plant Cell* 13:2513-2523.

## N

Nakamura T, Ohno T, Hirota K, Nishiyama A, Nakamura H, Wada H, Yodoi J. (1999) Mouse glutaredoxin - cDNA cloning, high level expression in *E. coli* and its possible implication in redox regulation of the DNA binding activity in transcription factor PEBP2. *Free Radic. Res.* 31:357-365.

Nathan C, Shiloh MU. (2000) Reactive oxygen and nitrogen intermediates in the relationship between mammalian hosts and microbial pathogens. *Proc. Natl. Acad. Sci. USA* 97:8841-8848.

Navaza J. (1994) AmoRe : an automated package for molecular replacement. *Acta Crystallogr. A Biol. Crystallogr.* 50:157-163.

Neill S, Desikan R, Hancock J. (2002a) Hydrogen peroxide signalling. *Curr. Opin. Plant Biol.* 5:388-395.

Neill SJ, Desikan R, Clarke A, Hancock JT. (2002b) Nitric oxide is a novel component of abscisic acid signaling in stomatal guard cells. *Plant Physiol.* 128:13-6.

Nemoto Y, Yamamoto T, Takada S, Matsui Y, Obinata M. (1990) Antisense RNA of the latent period gene (MER5) inhibits the differentiation of murine erythroleukemia cells. *Gene* 91:261-265.

Niimura Y, Poole LB, Massey V. (1995) *Amphibacillus xylanus* NADH oxidase and *Salmonella typhimurium* alkyl-hydroperoxide reductase flavoprotein components show extremely high scavenging activity for both alkyl hydroperoxide and hydrogen peroxide in the presence of *S. typhimurium* alkyl-hydroperoxide reductase 22-kDa protein component. J. Biol. Chem. 270:25645-25650.

Nikkola M, Gleason FK, Saarinen M, Joelson T, Bjornberg O, Eklund H. (1991) A putative glutathione-binding site in T4 glutaredoxin investigated by site-directed mutagenesis. J. Biol. Chem. 266:16105-16112.

Nishinaka Y, Masutani H, Nakamura H, Yodoi J. (2001) Regulatory roles of thioredoxin in oxidative stress-induced cellular responses. Redox Rep. 6:289-295.

Noctor G, Foyer CH. (1998) Ascorbate and glutathione : keeping active oxygen under control. Annu. Rev. Plant Physiol. Plant Mol. Biol. 49:249-279.

Nogoceke E, Gommel DU, Kiess M, Kalisz HM, Flohe L. (1997) A unique cascade of oxidoreductases catalyses trypanothione-mediated peroxide metabolism in *Crithidia fasciculata*. Biol. Chem. 378:827-836.

Nordstrand K, Aslund F, Holmgren A, Otting G, Berndt KD. (1999) NMR structure of *Escherichia coli* glutaredoxin 3-glutathione mixed disulfide complex: implications for the enzymatic mechanism. J. Mol. Biol. 286:541-552.

Nordstrand K, Sandstrom A, Aslund F, Holmgren A, Otting G, Berndt KD. (2000) NMR structure of oxidized glutaredoxin 3 from *Escherichia coli*. J. Mol. Biol. 303:423-432.

Novoselov SV, Rao M, Onoshko NV, Zhi H, Kryukov GV, Xiang Y, Weeks DP, Hatfield DL, Gladyshev VN. (2002) Selenoproteins and selenocysteine insertion system in the model plant cell system, *Chlamydomonas reinhardtii*. EMBO J. 21:3681-3693.

**O**

Olry A, Boschi-Muller S, Marraud M, Sanglier-Cianferani S, Van Dorsselaar A, Branlant G. (2002) Characterization of the methionine sulfoxide reductase activities of PILB, a probable virulence factor from *Neisseria meningitidis*. J. Biol. Chem. 277:12016-12022.

Otwinowski Z, Minor W. (1997) Processing of X-ray diffraction data collected in oscillation mode. Methods Enzymol. 276:307-326.

**P**

Padh H. (1990) Cellular functions of ascorbic acid. Biochem. Cell. Biol. 68:1166-1173.

Padilla CA, Spyrou G, Holmgren A. (1996) High-level expression of fully active human glutaredoxin (thioltransferase) in *E. coli* and characterization of Cys7 to Ser mutant protein. FEBS Lett. 378:69-73.

Park SG, Cha MK, Jeong W, Kim IH. (2000) Distinct physiological functions of thiol peroxidase isoenzymes in *Saccharomyces cerevisiae*. J. Biol. Chem. 275:5723-5732.

Pedrajas JR, Kosmidou E, Miranda-Vizuete A, Gustafsson JA, Wright AP, Spyrou G. (1999) Identification and functional characterization of a novel mitochondrial thioredoxin system in *Saccharomyces cerevisiae*. J. Biol. Chem. 274:6366-6373.

Pedrajas JR, Miranda-Vizuete A, Javanmardy N, Gustafsson JA, Spyrou G. (2000) Mitochondria of *Saccharomyces cerevisiae* contain one-conserved cysteine type peroxiredoxin with thioredoxin peroxidase activity. J. Biol. Chem. 275:16296-16301.

Pei ZM, Murata Y, Benning G, Thomine S, Klusener B, Allen GJ, Grill E, Schroeder JI. (2000) Calcium channels activated by hydrogen peroxide mediate abscisic acid signalling in guard cells. Nature 406:731-734.



Peshenko IV, Shichi H. (2001) Oxidation of active center cysteine of bovine 1-Cys peroxiredoxin to the cysteine sulfenic acid form by peroxide and peroxynitrite. *Free Radic. Biol. Med.* 31:292-303.

Petropoulos I, Mary J, Perichon M, Friguet B. (2001) Rat peptide methionine sulphoxide reductase: cloning of the cDNA, and down-regulation of gene expression and enzyme activity during aging. *Biochem. J.* 355:819-825.

Poole ES, Brown CM, Tate WP. (1995) The identity of the base following the stop codon determines the efficiency of *in vivo* translational termination in *Escherichia coli*. *EMBO J.* 14:151-158.

Poole LB. (1996) Flavin-dependent alkyl hydroperoxide reductase from *Salmonella typhimurium*. 2. Cystine disulfides involved in catalysis of peroxide reduction. *Biochemistry* 35:65-75.

Potamitou A, Holmgren A, Vlamis-Gardikas A. (2002) Protein levels of *Escherichia coli* thioredoxins and glutaredoxins and their relation to null mutants, growth phase, and function. *J. Biol. Chem.* 277:18561-18567.

Powis G, Mustacich D, Coon A. (2000) The role of the redox protein thioredoxin in cell growth and cancer. *Free Radic. Biol. Med.* 29:312-322.

Prieto-Alamo MJ, Jurado J, Gallardo-Madueno R, Monje-Casas F, Holmgren A, Pueyo C. (2000) Transcriptional regulation of glutaredoxin and thioredoxin pathways and related enzymes in response to oxidative stress. *J. Biol. Chem.* 275:13398-13405.

Prinz WA, Aslund F, Holmgren A, Beckwith J. (1997) The role of the thioredoxin and glutaredoxin pathways in reducing protein disulfide bonds in the *Escherichia coli* cytoplasm. *J. Biol. Chem.* 272:15661-15667.

Prosperi MT, Ferbus D, Rouillard D, Goubin G. (1998) The *pag* gene product, a physiological inhibitor of c-abl tyrosine kinase, is overexpressed in cells entering S phase and by contact with agents inducing oxidative stress. FEBS Lett. 423:39-44.

Prouzet-Mauleon V, Monribot-Espagne C, Boucherie H, Lagniel G, Lopez S, Labarre J, Garin J, Lauquin GJ. (2002) Identification in *Saccharomyces cerevisiae* of a new stable variant of alkyl hydroperoxide reductase 1 (Ahp1) induced by oxidative stress. J. Biol. Chem. 277:4823-4830.

## Q

Qin J, Yang Y, Velyvis A, Gronenborn A. (2000) Molecular views of redox regulation: three-dimensional structures of redox regulatory proteins and protein complexes. Antioxid. Redox Signal. 2:827-840.

## R

Rabilloud T, Heller M, Gasnier F, Luche S, Rey C, Aebersold R, Benahmed M, Louisot P, Lunardi J. (2002) Proteomics analysis of cellular response to oxidative stress. Evidence for *in vivo* overoxidation of peroxiredoxins at their active site. J. Biol. Chem. 277:19396-19401.

Rahlfs S, Fischer M, Becker K. (2001) *Plasmodium falciparum* possesses a classical glutaredoxin and a second, glutaredoxin-like protein with a PICOT homology domain. J. Biol. Chem. 276:37133-37140.

Raines CA, Lloyd JC, Longstaff M, Bradley D, Dyer T. (1988) Chloroplast fructose-1,6-bisphosphatase: the product of a mosaic gene. Nucleic Acids Res. 16:7931-7942.

Reichheld JP, Mestres-Ortega D, Laloi C, Meyer Y. (2002) The multigenic family of thioredoxin h in *Arabidopsis thaliana*: specific expression and stress response. Plant Physiol. Biochem. 40:685-690.

Ren D, Yang H, Zhang S. (2002) Cell death mediated by MAPK is associated with hydrogen peroxide production in *Arabidopsis*. J. Biol. Chem. 2002 277:559-565.

Rey P, Pruvot G, Becuwe N, Eymery F, Rumeau D, Peltier G. (1998) A novel thioredoxin-like protein located in the chloroplast is induced by water deficit in *Solanum tuberosum* L. plants. Plant J. 13:97-107.

Reynolds CM, Meyer J, Poole LB. (2002) An NADH-dependent bacterial thioredoxin reductase-like protein in conjunction with a glutaredoxin homologue form a unique peroxiredoxin (AhpC) reducing system in *Clostridium pasteurianum*. Biochemistry 41:1990-2001.

Rhee SG, Kim KH, Chae HZ, Yim MB, Uchida K, Netto LE, Stadtman ER. (1994) Antioxidant defense mechanisms: a new thiol-specific antioxidant enzyme. Ann. N. Y. Acad. Sci. 738:86-92.

Rhee SG, Kang SW, Netto LE, Seo MS, Stadtman ER. (1999) A family of novel peroxidases, peroxiredoxins. Biofactors 10:207-209.

Rhoads DM, Umbach AL, Sweet CR, Lennon AM, Rauch GS, Siedow JN. (1998) Regulation of the cyanide-resistant alternative oxidase of plant mitochondria. Identification of the cysteine residue involved in alpha-keto acid stimulation and intersubunit disulfide bond formation. J. Biol. Chem. 273:30750-30756.

Richardson JM, Lemaire SD, Jacquot JP, Makhatadze GI. (2000) Difference in the mechanisms of the cold and heat induced unfolding of thioredoxin h from *Chlamydomonas reinhardtii*: spectroscopic and calorimetric studies. Biochemistry 39:11154-11162.

Rintamaki E, Martinsuo P, Pursiheimo S, Aro EM. (2000) Cooperative regulation of light-harvesting complex II phosphorylation via the plastoquinol and ferredoxin-thioredoxin system in chloroplasts. Proc. Natl. Acad. Sci. USA 97:11644-11649.

Rivera-Madrid R, Mestres D, Marinho P, Jacquot JP, Decottignies P, Miginiac-Maslow M, Meyer Y. (1995) Evidence for five divergent thioredoxin h sequences in *Arabidopsis thaliana*. Proc. Natl. Acad. Sci. USA 92:5620-5624.

Rodriguez AA, Grunberg KA, Taleisnik EL. (2002) Reactive oxygen species in the elongation zone of maize leaves are necessary for leaf extension. Plant Physiol. 129:1627-1632.

Rodriguez-Manzaneque MT, Ros J, Cabisco E, Sorribas A, Herrero E. (1999) Grx5 glutaredoxin plays a central role in protection against protein oxidative damage in *Saccharomyces cerevisiae*. Mol. Cell. Biol. 19:8180-8190.

Rodriguez-Manzaneque MT, Tamarit J, Belli G, Ros J, Herrero E. (2002) Grx5 is a mitochondrial glutaredoxin required for the activity of iron/sulfur enzymes. Mol. Biol. Cell. 13:1109-1121.

Roth M, Carpentier P, Kaikati O, Joly J, Charrault P, Pirocchi M, Kahn R, Fanchon E, Jacquamet L, Borel F, Bertoni A, Israel-Gouy P, Ferrer JL. (2002) FIP: a highly automated beamline for multiwavelength anomalous diffraction experiments. Acta Crystallogr. D Biol. Crystallogr. 58:805-814.

Ruan H, Tang XD, Chen ML, Joiner ML, Sun G, Brot N, Weissbach H, Heinemann SH, Iverson L, Wu CF, Hoshi T, Chen ML, Joiner MA, Heinemann SH. (2002) High-quality life extension by the enzyme peptide methionine sulfoxide reductase. Proc. Natl. Acad. Sci. USA 99:2748-2753.

Ruelland E, Johansson K, Decottignies P, Djukic N, Miginiac-Maslow M. (1998) The autoinhibition of sorghum NADP malate dehydrogenase is mediated by a C-terminal negative charge. J. Biol. Chem. 273:33482-33488.

Ruelland E, Miginiac-Maslow M. (1999) Regulation of chloroplast enzyme activities by thioredoxins: activation or relief from inhibition? Trends Plant Sci. 4:136-141.

Russel M, Model P. (1986) The role of thioredoxin in filamentous phage assembly. Construction, isolation, and characterization of mutant thioredoxins. *J. Biol. Chem.* 261:14997-15005.

Russel M, Model P, Holmgren A. (1990) Thioredoxin or glutaredoxin in *Escherichia coli* is essential for sulfate reduction but not for deoxyribonucleotide synthesis. *J. Bacteriol.* 172:1923-1929.

## S

Sadanandom A, Piffanelli P, Knott T, Robinson C, Sharpe A, Lydiat D, Murphy D, Fairbairn DJ. (1996) Identification of a peptide methionine sulfoxide reductase gene in an oleosin promoter from *Brassica napus*. *Plant J.* 10:235-242.

Sadanandom A, Poghosyan Z, Fairbairn DJ, Murphy DJ. (2000) Differential regulation of plastidial and cytosolic isoforms of peptide methionine sulfoxide reductase in *Arabidopsis*. *Plant Physiol.* 123:255-264.

St John G, Brot N, Ruan J, Erdjument-Bromage H, Tempst P, Weissbach H, Nathan C. (2001) Peptide methionine sulfoxide reductase from *Escherichia coli* and *Mycobacterium tuberculosis* protects bacteria against oxidative damage from reactive nitrogen intermediates. *Proc. Natl. Acad. Sci. USA* 98:9901-9906.

Saitoh M, Nishitoh H, Fujii M, Takeda K, Tobiume K, Sawada Y, Kawabata M, Miyazono K, Ichijo H. (1998) Mammalian thioredoxin is a direct inhibitor of apoptosis signal-regulating kinase (ASK) 1. *EMBO J.* 17:2596-2606.

Sakamoto A, Tsukamoto S, Yamamoto H, Ueda-Hashimoto M, Takahashi M, Suzuki H, Morikawa H. (2003) Functional complementation in yeast reveals a protective role of chloroplast 2-Cys peroxiredoxin against reactive nitrogen species. *Plant J.* 233:841-851.

Sambrook J, Frisch EF, Maniatis T. (1989) *Molecular cloning: A laboratory manual*, Cold Spring Harbor, NY.

Santandrea G, Guo Y, O'Connell T, Thompson RD. (2002) Post-phloem protein trafficking in the maize caryopsis : zmTRXh1, a thioredoxin specifically expressed in the pedicel parenchyma of *Zea mays* L., is found predominantly in the placentochalaza. *Plant Mol. Biol.* 50:743-756.

Sasaki Y, Kozaki A, Hatano M. (1997) Link between light and fatty acid synthesis: thioredoxin-linked reductive activation of plastidic acetyl-CoA carboxylase. *Proc. Natl. Acad. Sci. USA* 94:11096-11101.

Sasaki T, Chino M, Hayashi H, Fujiwara T. (1998) Detection of several mRNA species in rice phloem sap. *Plant Cell Physiol.* 39:895-897.

Sauge-Merle S, Falconet D, Fontecave M. (1999) An active ribonucleotide reductase from *Arabidopsis thaliana* cloning, expression and characterization of the large subunit. *Eur. J. Biochem.* 266:62-69.

Saze H, Ueno Y, Hisabori T, hayashi H, Izui K. (2002) Thioredoxin mediated reductive activation of a protein kinase for the regulatory phosphorylation of C4-form phosphoenolpyruvate carboxylase from maize. *Plant Cell Physiol.* 42:1295-1302.

Schenk PM, Baumann S, Mattes R, Steinbiss HH. (1995) Improved high-level expression system for eukaryotic genes in *Escherichia coli* using T7 RNA polymerase and rare Arg tRNA's. *Biotechniques* 19:196-200.

Schmitter JM, Jacquot JP, de Lamotte-Guéry F, Beauvallet C, Dutka S, Gadal P, Decottignies P. (1988) Purification, properties and complete amino acid sequence of ferredoxin from a green alga, *Chlamydomonas reinhardtii*. *Eur. J. Biochem.* 172:405-412.

Schröder E, Ponting CP. (1998) Evidence that peroxiredoxins are novel members of the thioredoxin fold superfamily. *Protein Sci.* 7:2465-2468.

Schröder E, Littlechild JA, Lebedev AA, Errington N, Vagin AA, Isupov MN. (2000) Crystal structure of decameric 2-Cys peroxiredoxin from human erythrocytes at 1.7 Å resolution. *Structure Fold Des.* 8:605-615.

Schürmann P, Jacquot JP. (2000) Plant thioredoxin systems revisited. *Annu. Rev. Plant Physiol. Plant Mol. Biol.* 51:371-400.

Schwarz O, Schurmann P, Strotmann H. (1997) Kinetics and thioredoxin specificity of thiol modulation of the chloroplast H<sup>+</sup>-ATPase. *J. Biol. Chem.* 272:16924-16927.

Schwenn JD. (1989) Sulphate assimilation in higher plants: a thioredoxin PAPS reductase from spinach leaves. *Z. Naturforsch.* 4c:504-508.

Seo MS, Kang SW, Kim K, Baines IC, Lee TH, Rhee SG. (2000) Identification of a new type of mammalian peroxiredoxin that forms an intramolecular disulfide as a reaction intermediate. *J. Biol. Chem.* 275:20346-20354.

Serrato AJ, Crespo JL, Florencio FJ, Cejudo FJ. (2001) Characterization of two thioredoxins h with predominant localization in the nucleus of aleurone and scutellum cells of germinating wheat seeds. *Plant Mol. Biol.* 46:361-371.

Sha S, Minakuchi K, Higaki N, Sato K, Ohtsuki K, Kurata A, Yoshikawa H, Kotaru M, Masumura T, Ichihara K, Tanaka K. (1997) Purification and characterization of glutaredoxin (thioltransferase) from rice (*Oryza sativa* L.). *J. Biochem.* 121:842-848.

Sharov VS, Ferrington DA, Squier TC, Schoneich C. (1999) Diastereoselective reduction of protein-bound methionine sulfoxide by methionine sulfoxide reductase. *FEBS Lett.* 455:247-250.

Shenton D, Perrone G, Quinn KA, Dawes IW, Grant CM. (2002) Regulation of protein S-thiolation by glutaredoxin 5 in the yeast *Saccharomyces cerevisiae*. *J. Biol. Chem.* 277:16853-16859.

Shi J, Vlamis-Gardikas A, Aslund F, Holmgren A, Rosen BP. (1999) Reactivity of glutaredoxins 1, 2, and 3 from *Escherichia coli* shows that glutaredoxin 2 is the primary hydrogen donor to ArsC-catalyzed arsenate reduction. J. Biol. Chem. 274:36039-36042.

Shikanai T, Takeda T, Yamauchi H, Sano S, Tomizawa KI, Yokota A, Shigeoka S. (1998) Inhibition of ascorbate peroxidase under oxidative stress in tobacco having bacterial catalase in chloroplasts. FEBS Lett. 428:47-51.

Shin SH, Wong JH, Kobrehel K, Buchanan BB. (1993) Reduction of castor-seed 2S albumin protein by thioredoxin. Planta 189:557-560.

Singh VK, Moskovitz J, Wilkinson BJ, Jayaswal RK. (2001) Molecular characterization of a chromosomal locus in *Staphylococcus aureus* that contributes to oxidative defence and is highly induced by the cell-wall-active antibiotic oxacillin. Microbiology 147:3037-3045.

Skaar EP, Tobiason DM, Quick J, Judd RC, Weissbach H, Etienne F, Brot N, Seifert HS. (2002) The outer membrane localization of the *Neisseria gonorrhoeae* MsrA/B is involved in survival against reactive oxygen species. Proc. Natl. Acad. Sci. USA 99:10108-10113.

Sodano P, Xia TH, Bushweller JH, Bjornberg O, Holmgren A, Billeter M, Wuthrich K. (1991) Sequence-specific <sup>1</sup>H n.m.r. assignments and determination of the three-dimensional structure of reduced *Escherichia coli* glutaredoxin. J. Mol. Biol. 221:1311-1324.

Song JJ, Lee YJ. (2003) Differential role of glutaredoxin and thioredoxin in metabolic oxidative stress-induced ASK1 activation. Biochem. J. Sous presse.

Spector D, Etienne F, Brot N, Weissbach H. (2003) New membrane-associated and soluble peptide methionine sulfoxide reductases in *Escherichia coli*. Biochem. Biophys. Res. Commun. 302:284-289.



Stacy RA, Munthe E, Steinum T, Sharma B, Aalen RB. (1996) A peroxiredoxin antioxidant is encoded by a dormancy-related gene, *per1*, expressed during late development in the aleurone and embryo of barley grains. *Plant Mol. Biol.* 31:1205-1216.

Stacy RA, Nordeng TW, Culianez-Macia FA, Aalen RB. (1999) The dormancy-related peroxiredoxin anti-oxidant, PER1, is localized to the nucleus of barley embryo and aleurone cells. *Plant J.* 19:1-8.

Stadtman ER, Moskovitz J, Berlett BS, Levine RL. (2002) Cyclic oxidation and reduction of protein methionine residues is an important antioxidant mechanism. *Mol. Cell. Biochem.* 234:3-9.

Staples CR, Gaymard E, Stritt-Etter AL, Telser J, Hoffman BM, Schurmann P, Knaff DB, Johnson MK. (1998) Role of the [4Fe4S] cluster in mediating disulfide reduction in spinach ferredoxin:thioredoxin reductase. *Biochemistry* 37:4612-4620.

Starke DW, Chock PB, Mieyal JJ. (2003) Glutathione-thiyl radical scavenging and transferase properties of human glutaredoxin (thioltransferase). Potential role in redox signal transduction. *J. Biol. Chem.* 278:14607-14613.

Stehr M, Schneider G, Aslund F, Holmgren A, Lindqvist Y. (2001) Structural basis for the thioredoxin-like activity profile of the glutaredoxin-like NrdH-redoxin from *Escherichia coli*. *J. Biol. Chem.* 276:35836-35841.

Stein M, Jacquot JP, Jeannette E, Decottignies P, Hodges M, Lancelin JM, Mittard V, Schmitter JM, Miginiac-Maslow M. (1995) *Chlamydomonas reinhardtii* thioredoxins: structure of the genes coding for the chloroplastic *m* and cytosolic *h* isoforms; expression in *Escherichia coli* of the recombinant proteins, purification and biochemical properties. *Plant Mol. Biol.* 28:487-503.

Steinert P, Plank-Schumacher K, Montemartini M, Hecht HJ, Flohe L. (2000) Permutation of the active site motif of tryparedoxin 2. *Biol. Chem.* 381:211-219.

Stewart EJ, Aslund F, Beckwith J. (1998) Disulfide bond formation in the *Escherichia coli* cytoplasm : an in vivo role reversal for the thioredoxins. EMBO J. 17:5543-5550.

Sullivan DM, Wehr NB, Fergusson MM, Levine RL, Finkel T. (2000) Identification of oxidant-sensitive proteins: TNF-alpha induces protein glutathiolation. Biochemistry 39:11121-11128.

Sun C, Holmgren A, Bushweller JH. (1997) Complete  $^1\text{H}$ ,  $^{13}\text{C}$ , and  $^{15}\text{N}$  NMR resonance assignments and secondary structure of human glutaredoxin in the fully reduced form. Protein Sci. 6:383-390.

Sun C, Berardi MJ, Bushweller JH. (1998) The NMR solution structure of human glutaredoxin in the fully reduced form. J. Mol. Biol. 280:687-701.

Sun H, Gao J, Ferrington DA, Biesiada H, Williams TD, Squier TC. (1999) Repair of oxidized calmodulin by methionine sulfoxide reductase restores ability to activate the plasma membrane Ca-ATPase. Biochemistry 38:105-112.

Sun QA, Kirnarsky L, Sherman S, Gladyshev VN. (2001) Selenoprotein oxidoreductase with specificity for thioredoxin and glutathione systems. Proc. Natl. Acad. Sci. USA 98:3673-3678.

Sweetlove LJ, Heazlewood JL, Herald V, Holtzapffel R, Day DA, Leaver CJ, Millar AH. (2002) The impact of oxidative stress on *Arabidopsis* mitochondria. Plant J. 32:891-904.

Szederkényi J, Komor E, Schobert C. (1997) Cloning of the cDNA for glutaredoxin, an abundant sieve-tube exudate protein from *Ricinus communis* L. and characterisation of the glutathione-dependent thiol-reduction system in sieve tubes. Planta 202:349-356.

**T**

- Taha MK, Dupuy B, Saurin W, So M, Marchal C. (1991) Control of pilus expression in *Neisseria gonorrhoeae* as an original system in the family of two-component regulators. *Mol. Microbiol.* 5:137-148.
- Tamburro A, Allocati N, Masulli M, Rotilio D, Di Ilio C, Favaloro B. (2001) Bacterial peptide methionine sulphoxide reductase: co-induction with glutathione S-transferase during chemical stress conditions. *Biochem. J.* 360:675-681.
- Tete-Favier F, Cobessi D, Boschi-Muller S, Azza S, Branlant G, Aubry A. (2000) Crystal structure of the *Escherichia coli* peptide methionine sulphoxide reductase at 1.9 Å resolution. *Structure Fold Des.* 8:1167-1178.
- Tiwari BS, Belenghi B, Levine A. (2002) Oxidative stress increased respiration and generation of reactive oxygen species, resulting in ATP depletion, opening of mitochondrial permeability transition, and programmed cell death. *Plant Physiol.* 128:1271-1281.
- Trebitsh T, Meiri E, Ostersetzer O, Adam Z, Danon A. (2001) The protein disulfide isomerase-like RB60 is partitioned between stroma and thylakoids in *Chlamydomonas reinhardtii* chloroplasts. *J. Biol. Chem.* 276:4564-4569.
- Tron AE, Bertoncini CW, Chan RL, Gonzalez DH. (2002) Redox regulation of plant homeodomain transcription factors. *J. Biol. Chem.* 277:34800-34807.
- Trotter EW, Grant CM. (2003) Non-reciprocal regulation of the redox state of the glutathione-glutaredoxin and thioredoxin systems. *EMBO Rep.* 4:184-188.
- Tsukihara T, Fukuyama K, Mizushima M, Harioka T, Kusunoki M, Katsube Y, Hase T, Matsubara H. (1990) Structure of the [2Fe-2S] ferredoxin I from the blue-green alga *Aphanothece sacrum* at 2.2 Å resolution. *J. Mol. Biol.* 216:399-410.

Van Camp W, Van Montagu M, Inze D. (1998) H<sub>2</sub>O<sub>2</sub> and NO : redox signal in disease resistance. *Trends Plant Sci.* 3:330-334.

Vanlerberghe GC, McIntosh L, Yip JY. (1998) Molecular localization of a redox-modulated process regulating plant mitochondrial electron transport. *Plant Cell* 10:1551-1560.

Vassiliev IR, Jung YS, Yang F, Golbeck JH. (1998) PsaC subunit of photosystem I is oriented with iron-sulfur cluster F(B) as the immediate electron donor to ferredoxin and flavodoxin. *Biophys. J.* 74:2029-2035.

Verdoucq L, Vignols F, Jacquot JP, Chartier Y, Meyer Y. (1999) *In vivo* characterization of a thioredoxin h target protein defines a new peroxiredoxin family. *J. Biol. Chem.* 274:19714-19722.

Vergauwen B, Pauwels F, Jacquemotte F, Meyer TE, Cusanovich MA, Bartsch RG, Van Beeumen JJ. (2001) Characterization of glutathione amide reductase from *Chromatium gracile*. Identification of a novel thiol peroxidase (Prx/Grx) fueled by glutathione amide redox cycling. *J. Biol. Chem.* 276:20890-20897.

Vergauwen B, Pauwels F, Vaneechoutte M, Van Beeumen JJ. (2003) Exogenous glutathione completes the defense against oxidative stress in *Haemophilus influenzae*. *J. Bacteriol.* 185:1572-1581.

Vignols F, Mouaheb N, Thomas D, Meyer Y. (2003) Redox Control of Hsp70-Co-chaperone Interaction Revealed by Expression of a Thioredoxin-like *Arabidopsis* Protein. *J. Biol. Chem.* 278:4516-4523.

Villeret V, Huang S, Zhang Y, Xue Y, Lipscomb WN. (1995) Crystal structure of spinach chloroplast fructose-1,6-bisphosphatase at 2.8 Å resolution. *Biochemistry* 34:4299-4306.

Vlami-Gardikas A, Aslund F, Spyrou G, Bergman T, Holmgren A. (1997) Cloning, overexpression, and characterization of glutaredoxin 2, an atypical glutaredoxin from *Escherichia coli*. J. Biol. Chem. 272:11236-11243.

Vlami-Gardikas A, Holmgren A. (2002) Thioredoxin and glutaredoxin isoforms. Methods Enzymol. 347:286-296.

Vlami-Gardikas A, Potamitou A, Zarivach R, Hochman A, Holmgren A. (2002) Characterization of *Escherichia coli* null mutants for glutaredoxin 2. J. Biol. Chem. 277:10861-10868.

Vogt W. (1995) Oxidation of methionyl residues in proteins : tools, targets, and reversal. Free Radic. Biol. Med. 18:93-105.

Von Schaewen A, Langenkamper G, Graeve K, Wenderoth I, Scheibe R. (1995) Molecular characterization of the plastidic glucose-6-phosphate dehydrogenase from potato in comparison to its cytosolic counterpart. Plant Physiol. 109:1327-1335.

## **W**

Wang PF, Veine DM, Ahn SH, Williams CH. (1996) A stable mixed disulfide between thioredoxin reductase and its substrate, thioredoxin : preparation and characterization. Biochemistry 35:4812-4819.

Wang J, Boja ES, Tan W, Tekle E, Fales HM, English S, Mieyal JJ, Chock PB. (2001) Reversible glutathionylation regulates actin polymerization in A431 cells. J. Biol. Chem. 276:47763-47766.

Wangensteen OS, Chueca A, Hirasawa M, Sahrawy M, Knaff DB, Lopez Gorge J. (2001) Binding features of chloroplast fructose-1,6-bisphosphatase-thioredoxin interaction. Biochim. Biophys. Acta 154:156-166.

Watson JA, Rumsby MG, Wolowacz RG. (1999) Phage display identifies thioredoxin and superoxide dismutase as novel protein kinase C-interacting proteins: thioredoxin

inhibits protein kinase C-mediated phosphorylation of histone. *Biochem. J.* 343:301-305.

Weeks CM, Miller R. (1999) Optimizing Shake-and-Bake for proteins. *Acta Crystallogr. D Biol. Crystallogr.* 55:492-500.

Wells WW, Xu DP, Yang YF, Rocque PA. (1990) Mammalian thioltransferase (glutaredoxin) and protein disulfide isomerase have dehydroascorbate reductase activity. *J. Biol. Chem.* 265:15361-15364.

Wells WW, Yang Y, Deits TL, Gan ZR. (1993) Thioltransferases. *Adv. Enzymol. Relat. Areas Mol. Biol.* 66:149-201.

Wenderoth I, Scheibe R, von Schaewen A. (1997) Identification of the cysteine residues involved in redox modification of plant plastidic glucose-6-phosphate dehydrogenase. *J. Biol. Chem.* 272:26985-26990.

Wetterauer B, Véron M, Miginiac-Maslow, M, Decottignies P, Jacquot JP. (1992) Biochemical characterization of thioredoxin 1 from *Dictyostelium discoideum*. *Eur. J. Biochem.* 209:643-649.

Wieles B, Van Noort J, Drijfhout JW, Offringa R, Holmgren A, Ottenhoff TH. (1995) Purification and functional analysis of the *Mycobacterium leprae* thioredoxin/thioredoxin reductase hybrid protein. *J. Biol. Chem.* 270:25604-25606.

Winter J, Klappa P, Freedman RB, Lilie H, Rudolph R. (2002) Catalytic activity and chaperone function of human protein-disulfide isomerase are required for the efficient refolding of proinsulin. *J. Biol. Chem.* 277:310-317.

Wizemann TM, Moskovitz J, Pearce BJ, Cundell D, Arvidson CG, So M, Weissbach H, Brot N, Masure HR. (1996) Peptide methionine sulfoxide reductase contributes to the maintenance of adhesins in three major pathogens. *Proc. Natl. Acad. Sci. USA* 93:7985-7990.

Wolff SP. (1994) Ferrous ion oxidation of ferric ion indicator xylenol orange for measurement of hydroperoxides. *Methods Enzymol.* 233:182-189.

Wong CM, Zhou Y, Ng RW, Kung Hf HF, Jin DY. (2002) Cooperation of yeast peroxiredoxins Tsa1p and Tsa2p in the cellular defense against oxidative and nitrosative stress. *J. Biol. Chem.* 277:5385-5394.

Woo HA, Chae HZ, Hwang SC, Yang KS, Kang SW, Kim K, Rhee SG. (2003) Reversing the inactivation of peroxiredoxins caused by cysteine sulfinic acid formation. *Science* 300:653-656.

Wood ZA, Schroder E, Robin Harris J, Poole LB. (2003a) Structure, mechanism and regulation of peroxiredoxins. *Trends Biochem. Sci.* 28:32-40.

Wood ZA, Poole LB, Karplus PA. (2003b) Peroxiredoxin evolution and the regulation of hydrogen peroxide signaling. *Science.* 300:650-653.

Wu C, Colleoni C, Myers AM, James MG. (2002) Enzymatic properties and regulation of ZPU1, the maize pullulanase-type starch debranching enzyme. *Arch. Biochem. Biophys.* 406:21-32.

## X

Xia TH, Bushweller JH, Sodano P, Billeter M, Bjornberg O, Holmgren A, Wuthrich K. (1992) NMR structure of oxidized *Escherichia coli* glutaredoxin: comparison with reduced *E. coli* glutaredoxin and functionally related proteins. *Protein Sci.* 1:310-321.

Xia B, Vlamis-Gardikas A, Holmgren A, Wright PE, Dyson HJ. (2001) Solution structure of *Escherichia coli* glutaredoxin-2 shows similarity to mammalian glutathione-S-transferases. *J. Mol. Biol.* 310:907-918.

## Y

Yamamoto T, Matsui Y, Natori S, Obinata M. (1989) Cloning of a housekeeping-type gene (MER5) preferentially expressed in murine erythroleukemia cells. *Gene* 80:337-343.

Yamamoto Y. (2000) Fate of lipid hydroperoxides in blood plasma. *Free Radic. Res.* 33:795-800.

Yamashita H, Avraham S, Jiang S, London R, Van Veldhoven PP, Subramani S, Rogers RA, Avraham H. (1999) Characterization of human and murine PMP20 peroxisomal proteins that exhibit antioxidant activity *in vitro*. *J. Biol. Chem.* 274:29897-29904.

Yang Y, Jao SC, Nanduri S, Starke DW, Mieyal JJ, Qin J. (1998) Reactivity of the human thioltransferase (glutaredoxin) C7S, C25S, C78S, C82S mutant and NMR solution structure of its glutathionyl mixed disulfide intermediate reflect catalytic specificity. *Biochemistry* 37:17145-17156.

Yang T, Poovaiah BW. (2002a) Hydrogen peroxide homeostasis: activation of plant catalase by calcium/calmodulin. *Proc. Natl. Acad. Sci. USA* 99:4097-4102.

Yang KS, Kang SW, Woo HA, Hwang SC, Chae HZ, Kim K, Rhee SG. (2002b) Inactivation of human peroxiredoxin I during catalysis as the result of the oxidation of the catalytic site cysteine to cysteine-sulfinic acid. *J. Biol. Chem.* 277:38029-38036.

Yano H, Wong JH, Lee YM, Cho MJ, Buchanan BB. (2001) A strategy for the identification of proteins targeted by thioredoxin. *Proc. Natl. Acad. Sci. USA* 98:4794-4799.

Yao Y, Yin D, Jas GS, Kuczer K, Williams TD, Schoneich C, Squier TC. (1996) Oxidative modification of a carboxyl-terminal vicinal methionine in calmodulin by hydrogen peroxide inhibits calmodulin-dependent activation of the plasma membrane Ca-ATPase. *Biochemistry* 35:2767-2787.



Yohn CB, Cohen A, Danon A, Mayfield SP. (1998) A poly(A) binding protein functions in the chloroplast as a message-specific translation factor. Proc. Natl. Acad. Sci. USA 95: 2238-2243.

## Z

Zhang P, Liu B, Kang SW, Seo MS, Rhee SG, Obeid LM. (1997) Thioredoxin peroxidase is a novel inhibitor of apoptosis with a mechanism distinct from that of Bcl-2. J. Biol. Chem. 272:30615-30618.

Zhang N, Portis AR. (1999) Mechanism of light regulation of Rubisco: a specific role for the larger Rubisco activase isoform involving reductive activation by thioredoxin-f. Proc. Natl. Acad. Sci. USA 96:9438-9443.

Zhang X, Miao YC, An GY, Zhou Y, Shanguan ZP, Gao JF, Song CP. (2001a) K<sup>+</sup> channels inhibited by hydrogen peroxide mediate abscisic acid signaling in *Vicia* guard cells. Cell Res. 11:195-202.

Zhang X, Zhang L, Dong F, Gao J, Galbraith DW, Song CP. (2001b) Hydrogen peroxide is involved in abscisic acid-induced stomatal closure in *Vicia faba*. Plant Physiol. 126:1438-1448.

Zheng M, Aslund F, Storz G. (1998) Activation of the OxyR transcription factor by reversible disulfide bond formation. Science 279:1718-1721.

Zhou Y, Kok KH, Chun AC, Wong CM, Wu HW, Lin MC, Fung PC, Kung H, Jin DY. (2000) Mouse peroxiredoxin V is a thioredoxin peroxidase that inhibits p53-induced apoptosis. Biochem. Biophys. Res. Commun. 268:921-927.

**Résumé :** Le métabolisme cellulaire basal ainsi que les stress biotiques ou abiotiques génèrent des espèces réactives oxygénées (ROS) qui endommagent les macromolécules, protéines et lipides notamment. En maintenant l'équilibre oxydo-réducteur, les systèmes thiorédoxines et glutarédoxines permettent de lutter contre les ROS. Plusieurs variants moléculaires de ces protéines ont été caractérisés en utilisant une stratégie qui fait appel au clonage de séquences nucléotidiques, à l'expression de protéines recombinantes dans *Escherichia coli* et à la mutagenèse dirigée. Deux thiorédoxines et une glutarédoxine, toutes bicystéiniques, ont été ainsi caractérisées et leur mécanisme catalytique détaillé. De plus, la structure tridimensionnelle de la glutarédoxine de peuplier a pu être résolue par cristallographie. Notre intérêt s'est également porté sur deux types d'enzymes cibles des thiorédoxines et/ou des glutarédoxines, des peroxyrédoxines qui sont des peroxydases fonctionnant sans groupe prosthétique mais avec des cystéines réactives, et des méthionine sulfoxyde réductases de type A, qui réduisent l'isomère S des méthionine sulfoxydes en méthionine. Chez les plantes en général, et le peuplier en particulier, toutes ces protéines sont représentées par un grand nombre d'isoformes dans différents compartiments cellulaires. La caractérisation structurale et fonctionnelle de plusieurs isoformes de peroxyrédoxines et de méthionine sulfoxyde réductases de type A a permis d'identifier les acides aminés impliqués dans l'activité de ces protéines ainsi que ceux responsables des interactions protéine-protéine. Le résultat le plus original de ces travaux a été de montrer pour la première fois que les glutarédoxines peuvent servir de donneur d'électrons alternatifs et préférentiels pour une classe particulière de peroxyrédoxines. Outre la caractérisation moléculaire de ces systèmes, un travail d'expression et de localisation dans les différents organes de la plante a été entrepris.

**Mots clés :** glutarédoxines, hydroperoxydes, méthionine sulfoxyde réductases, peroxyrédoxines, peuplier, protéines, stress oxydant, thiorédoxines

**Title :** Functional and structural aspects of poplar thioredoxin and glutaredoxin systems and of their target enzymes, peroxiredoxins and type A methionine sulfoxide reductases.

**Abstract :** Basal cellular metabolism as well as biotic and abiotic stress conditions lead to the production of reactive oxygen species (ROS) which are extremely damaging to macromolecules including proteins and lipids. By maintaining the redox equilibrium, the thioredoxin and glutaredoxin systems help fight the damages generated by the ROS. Several molecular variants of these proteins have been characterized using strategies that combine nucleotidic sequence isolation, expression and mutagenesis of recombinant proteins in *Escherichia coli*. Two thioredoxins and one glutaredoxin, all bicysteinic, have been characterized and their catalytic mechanism detailed. Moreover, the 3D structure of poplar glutaredoxin has been solved by X-ray crystallography. This work has also focused on two thioredoxin/ glutaredoxin target enzymes, peroxiredoxins which are peroxydases devoid of prosthetic group and type A methionine sulfoxide reductases, which reduce S methionine sulfoxide into methionine. In plants in general and especially in poplar, there are several isoforms of these enzymes distributed in several subcellular compartments. The structural and functional characterization of several peroxiredoxin and type A methionine sulfoxide reductases has led to the identification of the active site amino acids as well as those necessary for the protein/protein interactions. The most original result is that glutaredoxin can serve as an alternative and preferential electron donor for a certain class of peroxiredoxins. In addition to the molecular characterization of these components, expression studies and localization experiments have been undertaken.

**Discipline :** Biochimie et Physiologie Végétale

**Adresse du laboratoire :** UMR 1136 INRA-UHP Université Henri Poincaré, Nancy I, Faculté des sciences, Entrée 1B 54500 Vandoeuvre