



HAL
open science

Modification et stabilisation de la réactivité de tanins traités chimiquement : applications à la préparation de résines adhésives et de mousses écosoutenables

Samuele Giovando

► To cite this version:

Samuele Giovando. Modification et stabilisation de la réactivité de tanins traités chimiquement : applications à la préparation de résines adhésives et de mousses écosoutenables. Alimentation et Nutrition. Université de Lorraine, 2013. Français. NNT : 2013LORR0227 . tel-01750522

HAL Id: tel-01750522

<https://hal.univ-lorraine.fr/tel-01750522v1>

Submitted on 29 Mar 2018

HAL is a multi-disciplinary open access archive for the deposit and dissemination of scientific research documents, whether they are published or not. The documents may come from teaching and research institutions in France or abroad, or from public or private research centers.

L'archive ouverte pluridisciplinaire **HAL**, est destinée au dépôt et à la diffusion de documents scientifiques de niveau recherche, publiés ou non, émanant des établissements d'enseignement et de recherche français ou étrangers, des laboratoires publics ou privés.



AVERTISSEMENT

Ce document est le fruit d'un long travail approuvé par le jury de soutenance et mis à disposition de l'ensemble de la communauté universitaire élargie.

Il est soumis à la propriété intellectuelle de l'auteur. Ceci implique une obligation de citation et de référencement lors de l'utilisation de ce document.

D'autre part, toute contrefaçon, plagiat, reproduction illicite encourt une poursuite pénale.

Contact : ddoc-theses-contact@univ-lorraine.fr

LIENS

Code de la Propriété Intellectuelle. articles L 122. 4

Code de la Propriété Intellectuelle. articles L 335.2- L 335.10

http://www.cfcopies.com/V2/leg/leg_droi.php

<http://www.culture.gouv.fr/culture/infos-pratiques/droits/protection.htm>

Université de Lorraine

Ecole Doctorale Sciences et Ingénierie des Ressources Procédés Produits et Environnement

Département de Formation Doctorale Sciences du Bois

THESE

Pour l'obtention du titre de

Docteur de l'Université de Lorraine

Spécialité : Sciences du Bois

Présentée par

Samuele GIOVANDO

**Modification et stabilisation de la réactivité de tanins
traités chimiquement : applications à la préparation de
résines adhésives et de mousses écosoutenables**

Soutenance prévue le 14 novembre 2013 devant le jury :

Rapporteurs

- M. Bertrand CHARRIER (Pr, IPREM, UPPA, Pau)
- M. Frédéric PICHELIN (Pr, HSB-BFH, Biel)

Examineurs

- M. Luc AVEROUS (Pr, ECPM-ICPEES, Strasbourg)
- M. André MERLIN (Pr, LERMAB, UL, Nancy)
- M. Antonio PIZZI (Pr, LERMAB, UL, Nancy)
- Mme. Béatrice GEORGE (MC, LERMAB, UL, Nancy)

Remerciements

A Les Institutions :

- A André Merlin, mon Directeur de thèse, pour la gentillesse de m'accueillir dans son groupe.
- A Prof. Antonio Pizzi, mon vrais Directeur de thèse, pour m'avoir chargé à faire sous forme de thèse nos projet de travail. Wow! c'a été possible!
- Une autre fois à Tony, pour sa familiarité et sa confiance. Pour la sensation qu'il me donne, d'être en train d'avoir un métier très promissent dans les mains. Peut-être qu'il soit vrais...
- A Silvateam et à Antonio, Michele et Stefano Battaglia pour leur confiance en moi et dans ce projet.
- A Beatrice George pour sa grande patience et sa disponibilité

A La Famille:

- A Marilena, mia moglie, che mi spinge a fare, e che ne accetta le conseguenze.
- A Beatrice, mia figlia, che ascoltando i miei sproloqui sui polifenoli, li ha ribattezzati i "pony e fagioli"!
- A Francesco, mio figlio appena nato, concepito sul percorso della tesi.

A Moi:

- Au nager à la piscine à penser aux résines de tanins!

Liste des publications et des brevets

- 1) **S.GIOVANDO**, A.PIZZI, H.PASCH, K.RODE, Synthetic tanins structure by MALDI-TOF mass spectrometry, *J.Appl.Polymer Sci.*, 114: 1339 - 1347 (2009)
- 2) A.PIZZI, H.PASCH, K.RODE, **S.GIOVANDO**, Polymer structure of commercial hydrolysable tanins by MALDI-TOF mass spectrometry, *J.Appl.Polymer Sci.*, 113 (6): 3847-3859 (2009)
- 3) C.BASSO, V.FIERRO, **S.GIOVANDO**, A.PIZZI, A.CELZARD, "Composizione per la fabbricazione di un materiale espanso a base di tanini, materiale espanso da essa ottenibile, e relativo procedimento di fabbricazione", Patent application number (Italy): TO2011A000656 (demande de brevet déposé le 21-07-2011), extended international PCT the 18/07/2012 with n. PCT/EP2012/003031.
- 4) M.C.BASSO, X.LI, **S.GIOVANDO**, V.FIERRO, A.PIZZI, A.CELZARD, Green, formaldehyde-free, foams for thermal insulation, *Advanced Materials Letters*, 2 (6): 378-382 (2011)
- 5) S.SPINA, X.ZHOU, C.SEGOVIA, A.PIZZI, M.ROMAGNOLI, **S.GIOVANDO**, H.PASCH, K.RODE, L.DELMOTTE, Phenolic resin adhesives based on chestnut hydrolysable tanins, *J.Adh.Sci.Technol*, DOI:10.1080/01694243.2012.697673 (2012)
- 6) **S.GIOVANDO**, M.C.BASSO, A.PIZZI, A.CELZARD, "Composizione a base di tanini, priva di formaldeide e di solventi organici bassobollenti, per la produzione di un materiale espanso, e relativo procedimento", Patent application number (Italy): TO2012A000860 (demande de brevet déposé le 02-10-2012)
- 7) N.RADEBE, K.RODE, A.PIZZI, **S.GIOVANDO**, H.PASCH, MALDI-TOF-CID for the Microstructure Elucidation of Polymeric Hydrolysable Tanins, *J.Appl.Polym.Sci.* 128: 97-107 (2013), DOI: 10.1002/APP.38156
- 8) **S.GIOVANDO**, A.PIZZI, H.PASCH, N.PRETORIUS, Structure and oligomers distribution of commercial Tara (*Caesalpinia spinosa*) hydrolysable tanin , *ProLigno*, 9 (1): 22-31 (2013)

9) S.SPINA, X.ZHOU, C.SEGOVIA, A.PIZZI, M.ROMAGNOLI, **S.GIOVANDO**, H.PASCH, K.RODE, L.DELMOTTE, Phenolic resin adhesives based on chestnut hydrolysable tanins, *Intern.Wood Prod.J.*, 4 (2): 95-100 (2013), DOI: 10.1179/2042645312Y.0000000020

10) M.C.BASSO, **S.GIOVANDO**, A.PIZZI, A.CELZARD, Tanin/furanic foams without blowing agents and formaldehyde, *Ind.Crops&Prods*, 49 (2013) 17- 22

Résumé

L'objectif de ce travail de thèse a été de produire des matériaux expansés à partir de produits d'origine naturelle, en particulier à partir de tanins.

Au moment où cette thèse a débuté, des études étaient publiées sur la possibilité d'élaborer ce type de matériaux avec des formulations similaires à celles des colles utilisées pour le bois mais qui comportaient du formaldéhyde. Cela allait à l'encontre du caractère naturel recherché puisqu'en fait, on utilisait des produits naturels et les mélangeait ou les faisait réagir avec des produits synthétiques irritants, toxiques voire cancérigènes. Il n'était donc pas possible de les présenter comme des matériaux « verts ».

Aussi, nous avons voulu au cours de ce travail, élaborer des matériaux expansés uniquement à partir de produits naturels ou en découlant.

Les tanins sont des substances naturelles chimiquement actives qui peuvent être utilisées afin de remplacer des produits homologues dérivés du pétrole comme le phénol par exemple qui présente des caractéristiques de réactivité chimique très similaires à celles des tanins condensés.

Des formulations comportant des tanins condensés ont d'ailleurs déjà été étudiées pour élaborer des matériaux expansés.

En considérant cela, ce travail de thèse s'est déroulé sous la forme de différents projets convergents vers un objectif commun : la production de mousses aux tanins plus naturelles et plus intéressantes pour l'industrie.

Cinq projets ont ainsi été menés :

1. analyses de différents tanins, condensés, hydrolysables et synthétiques;
2. production de mousses aux tanins sans utilisation de formaldéhyde;
3. production de mousses aux tanins sans solvants;
4. production de mousses aux tanins rigides ou élastiques;
5. production de mousses aux tanins, sans acides, mais avec une catalyse alcaline.

Sommaire

Introduction	1
Les tanins	2
Les tanins synthétiques.....	2
Les tanins végétaux : condensés et hydrolysables	4
Rôle naturel et propriétés	5
Processus d'extraction	6
Classification générale des tanins:	22
Réactivité des tanins condensés :	29
Réaction avec les aldéhydes.....	30
Réactivité avec le glyoxal	40
Autocondensation acide.....	41
Autocondensation alcaline	43
Autocondensation alcaline catalysée par la silice.	46
L'Alcool Furfurylique	48
Caractéristiques Physico-chimiques	48
Production de l'Alcool Furfurylique	49
Réactivité de l'alcool Furfurylique.....	51
Réactivité de l'alcool furfurylique avec les tanins	52
Les Mousses	54
Les mousses solides	56
Les mousses naturelles	58
Résultats et discussions	59
Caractérisation des tanins.	61
Structure moléculaire des tanins synthétiques par la spectrométrie de masse MALDI-TOF.....	61
Structure moléculaire des tanins hydrolysables commerciaux par la spectrométrie de masse MALDI-TOF.....	71
MALDI-TOF-CID pour l'élucidation de la microstructure des tanins hydrolysables polymères.	85
Structure et distribution des oligomères dans le tanin hydrolysable de Tara (Caesalpinia spinosa).	99
Nouvelles résines de tanins écosoutenables.....	111
Résines pour adhésifs phénoliques basés sur les tanins hydrolysables de châtaignier.	111
Une nouvelle recette de résines phénoliques à base de tanins de châtaignier.....	119

Mousses de tanins écosoutenables.	131
Mousses à base de tanins, sans formaldéhyde.	131
Mousses vertes, sans formaldéhyde, pour l'isolation thermique.	163
Mousses à base de tanins, sans formaldéhyde et sans solvant à bas point d'ébullition.	169
Mousses aux tanins et alcool furfurylique sans solvants organiques volatils et sans formaldéhyde.	207
Conclusions.....	217
Conclusions générales.....	217
Analyses des tanins, condensés, hydrolysables et synthétiques.....	217
Mousses aux tanins, sans utilisation de formaldéhyde	218
Mousses aux tanins, sans solvants	219
Mousses aux tanins, rigides ou élastiques	219
Mousses aux tanins polymérisables avec un catalyseur acide ou alcalin	220
Recommandations.....	223
Perspectives	225
Références.....	227

Introduction

Dans un monde où les ressources pétrolières se raréfient et dans lequel les matériaux polymères tiennent une très grande place, l'obtention de polymères à partir de produits naturels s'avère des plus intéressantes.

Le bois est une ressource très riche de ce point de vue parce qu'il est composé de macromolécules, telles que la cellulose, les hémicelluloses et la lignine et que les tanins qu'il renferme sont des composés polymérisables. Par ailleurs, il est possible d'obtenir à partir de diverses biomasses d'autres substances polymérisables comme le furfurol ou alcool furfurylique. Ces molécules naturelles sont en train de devenir très importantes dans l'industrie des polymères.

Les tanins

Le terme « tanins » englobe de manière large l'ensemble des composés tannants qu'ils soient synthétiques ou végétaux, condensés ou hydrolysables. Du point de vue chimique, ils ont tous en commun le fait qu'ils présentent des groupements – OH phénoliques et qu'ils sont réactifs vis-à-vis des protéines à pH acide et se colorent en bleu-noir avec les sels de fer.

Les tanins synthétiques



Les tanins synthétiques sont utilisés surtout pour le tannage des cuirs. Ils ont été synthétisés pour la première fois il y a environ un siècle, comme alternative aux tanins végétaux.

Ce sont des polymères qui résultent de la réaction du phénol, du naphthalène et de la dioxydiphénylsulfone sur le formaldéhyde et/ou l'urée.

Classiquement, du phénol est mis à réagir avec de l'acide sulfurique, pour donner du phénol sulfoné et/ou de la dioxydiphénylsulfone selon les conditions de température, de pression et les proportions des réactifs mis en jeu. Les produits sulfonés sont ensuite condensés avec le formaldéhyde en présence ou non d'urée. Les réactions chimiques générales sont décrites ci-dessous.

Sulfonation du phénol:

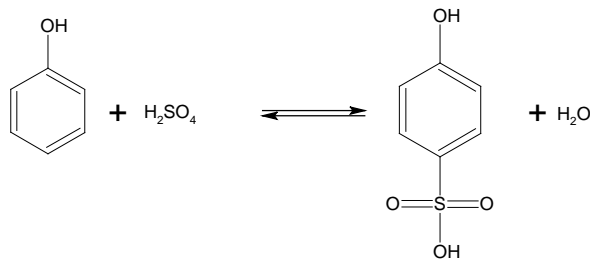

Production de la dioxydiphénylsulfone par réaction sur le phénol, puis séparation du phénol en excès et de l'eau formée par distillation:

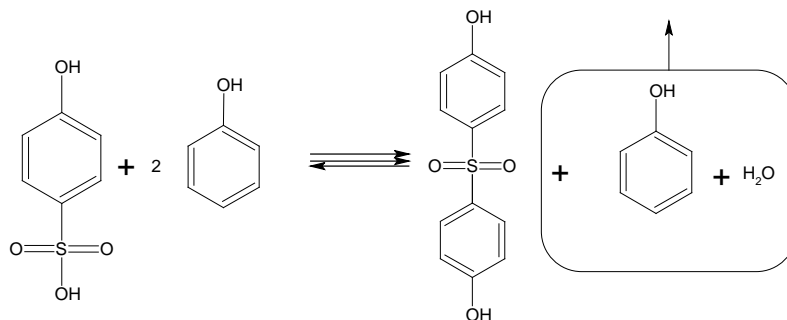

Condensation de la dioxydiphénylsulfone avec le formaldéhyde:

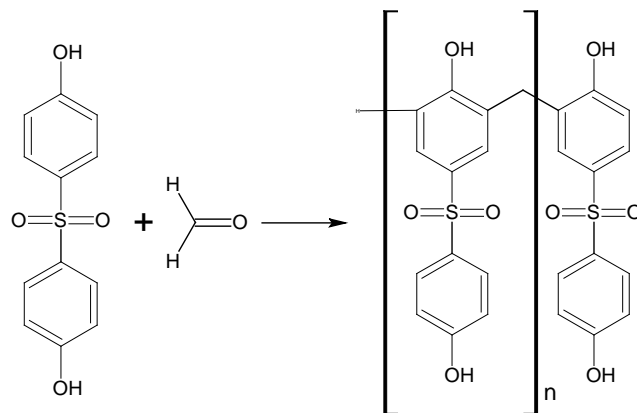

Condensation de l'acide phénolsulfonique avec le formaldéhyde et l'urée:

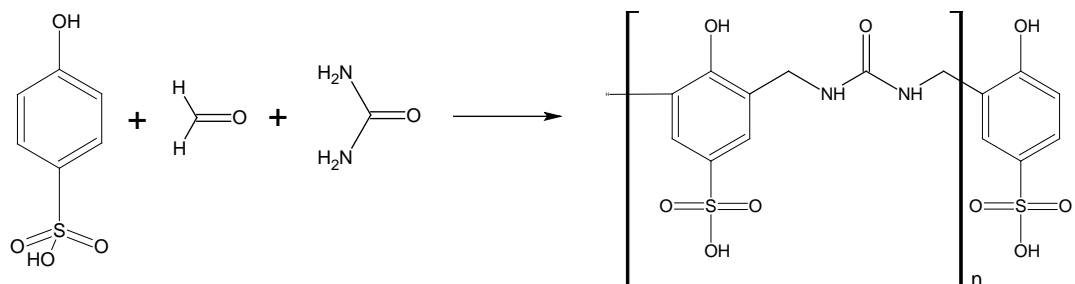

Les tanins végétaux : condensés et hydrolysables



Sur la base des structures moléculaires des tanins végétaux actuellement connus, et leur origine et leur rôle dans la vie des plantes, la définition suivante des tanins peut être employée:

Les tanins sont des métabolites secondaires polyphénoliques des plantes supérieures, et sont soit des esters galloyles et leurs dérivés, dans lesquels des fragments galloyles ou leurs dérivés sont attachés à une série de polyol, de noyaux catéchine et triterpénoïdes (gallotannins, ellagitannins et des tanins complexes), soit des oligomères et polymères proanthocyanidines pouvant posséder différents couplages interflavanyl et réseaux de substitution (tanins condensés) [Karamali Khanbabaee et Teunis van Ree – 2001].

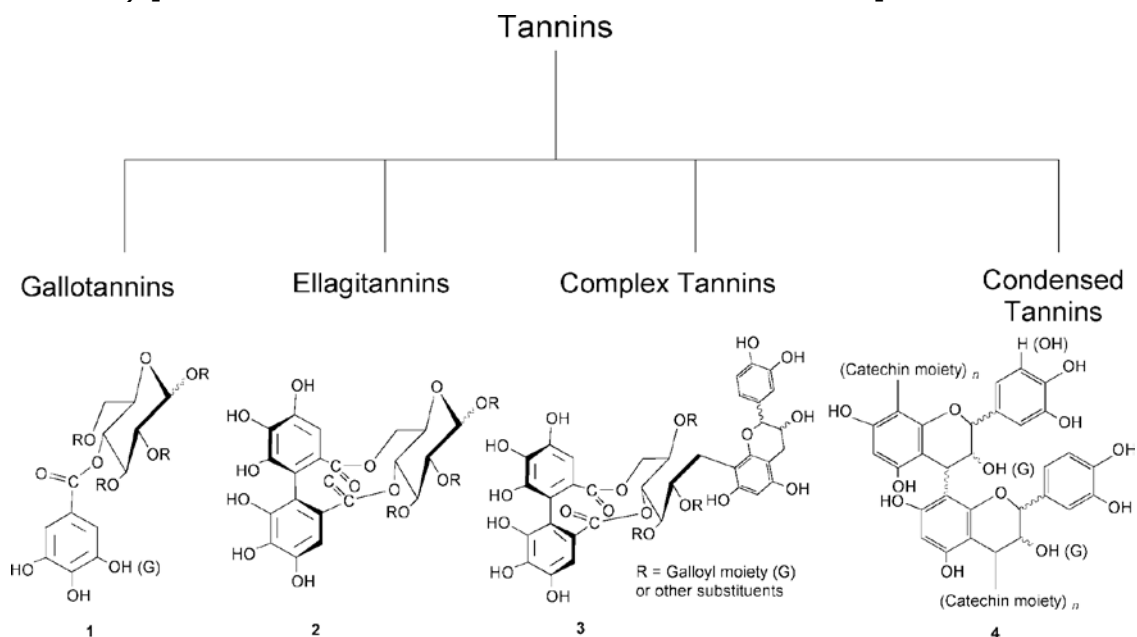

Rôle naturel et propriétés

Les tanins sont des composés polyphénoliques utilisés par les plantes pour se défendre des insectes et des champignons. La forte caractéristique d'astringence des tanins rend la plante plus difficilement assimilable par les animaux. Aussi il est possible de décrire les tanins comme de vrais " boucliers ". [Robbins et al, 1987]

Ces produits se trouvent dans toutes les plantes en différentes proportions. Les écorces des arbres en général contiennent le pourcentage le plus significatif, mais les tanins peuvent se trouver dans le cytoplasme de toutes les cellules végétales [Haslam, 1989].

Les différents bois stockent les tanins dans différentes zones de la plante :

Le pin (*Pinus radiata*), le chêne (*Quercus robur*) et le mimosa (*Acacia mearnsii* o *mollissima*) contiennent principalement des tanins dans l'écorce ; le gambier (*Uncaria Gambir*) dans les feuilles, le pecan (*Carya illinoensis*) dans les noix de moelle tandis que le châtaignier (*Castanea sativa*) et le quebracho (*Schinopsis balansae*) stockent leurs tanins dans toute la structure.

Les tanins végétaux malgré les différences de leurs constitutions possèdent un ensemble de caractères communs et peuvent se combiner aux protéines pour donner des complexes solubles ou insolubles:

- Ils précipitent les protéines de leur solution, en particulier la gélatine.
- Ils donnent avec les sels des métaux lourds des laques de couleurs variées ; en particulier avec les sels de fer, ils donnent des laques de couleur bleu noir.
- Ils précipitent avec les matières colorantes cationiques.
- Ils sont plus ou moins solubles dans l'eau, leurs solutions sont toujours acides. En raison de la grosseur de leurs molécules et de leur tendance à polymériser par oxydation, les solutions aqueuses de tanins se comportent comme des dispersions colloïdales.
- Ils sont amorphes et sans point de fusion précis.
- Ils sont capables de se fixer sur la substance dermique de la peau en tripe et de la transformer en cuir.

Processus d'extraction

L'extrait tannant est le résultat de la concentration par évaporation de l'eau de la solution obtenue par lessivage méthodique de la matière tannante naturelle.

L'extrait obtenu peut être liquide, c'est alors une solution concentrée contenant 50 % de matières sèches. Il est aujourd'hui le plus souvent solide, en poudre, et renferme 90 à 96 % de matières sèches. Les opérations nécessaires pour préparer un extrait tannant sont sensiblement les mêmes quelle que soit la matière tannante concernée. Pour décrire ces opérations, on prendra comme exemple la fabrication du tanin de châtaignier, de quebracho et de mimosa.

Fabrication du tanin de Châtaignier :

Le tanin de châtaignier provient du bois de châtaignier (*Castanea sativa*) qui pousse naturellement par exemple au pied des montagnes du centre-nord de l'Italie, dans la Slovénie et dans le centre de la France.

On utilise surtout des arbres de 20-40 ans qui doivent être abattus à cause de problèmes d'instabilité structurelle. La réimplantation n'est pas nécessaire grâce à la tendance naturelle du châtaignier à générer des drageons à partir des racines des arbres abattus.

Les troncs sont transportés jusqu'à des installations d'extraction et restent stockés en plein air environ 3-6 mois avant d'être utilisés. Le bois, après avoir été dépouillé de l'écorce, est coupé en petits morceaux de 1-4 cm qui sont chargés dans une batterie d'extracteurs remplis avec de l'eau à 105 °C environ. Le taux de matière sèche de 5% dans l'extrait est élevé à 10% par préconcentration dans un concentrateur à effet multiple, puis, après une phase de sédimentation, les hémicelluloses et les gommages végétales sont supprimées. Finalement l'extrait est concentré jusqu'à un taux d'environ 50% de matière sèche. Cette dernière solution aqueuse concentrée est envoyée dans un atomiseur qui permet de récupérer l'extrait en poudre.



La fabrication comprend donc cinq opérations principales :

- Découpage du bois
- Extraction du tanin
- Préconcentration et décantation des bouillons
- Concentration des bouillons
- Obtention de l'extrait solide

Rappelons que l'on exploite seulement le bois du tronc et des grosses branches. Ces parties de l'arbre sont refendues et découpées en billes de 1,5 à 2 cm de longueur, sur les lieux de l'exploitation. C'est donc sous cette forme que se présente la matière première pour la préparation de l'extrait.

Coupage du bois :

Le bois est découpé en copeaux taillés perpendiculairement à l'axe longitudinal de la bûche. L'épaisseur des copeaux a une grande influence sur la vitesse de diffusion de l'eau et par conséquent sur la vitesse d'extraction des produits solubles comme le montre le tableau suivant :

Epaisseur des copeaux en mm	18	15	10	5
Tanin extrait en 4 heures (en % de la teneur totale en tanin)	47	50	60	62

Tableau 1: Extrait de tanin en fonction de la taille des copeaux.

En général, l'épaisseur des copeaux est comprise entre 5 et 10 mm.

On utilise pour cette opération une découpeuse à tambour présentée en figure 1. Elle comprend un tambour (A) constitué par deux troncs de cône en acier assemblés par leur petite base. Il porte des lames (B) en acier, inclinées par rapport au rayon du tambour et dépassant celui-ci de l'épaisseur désirée pour les copeaux.

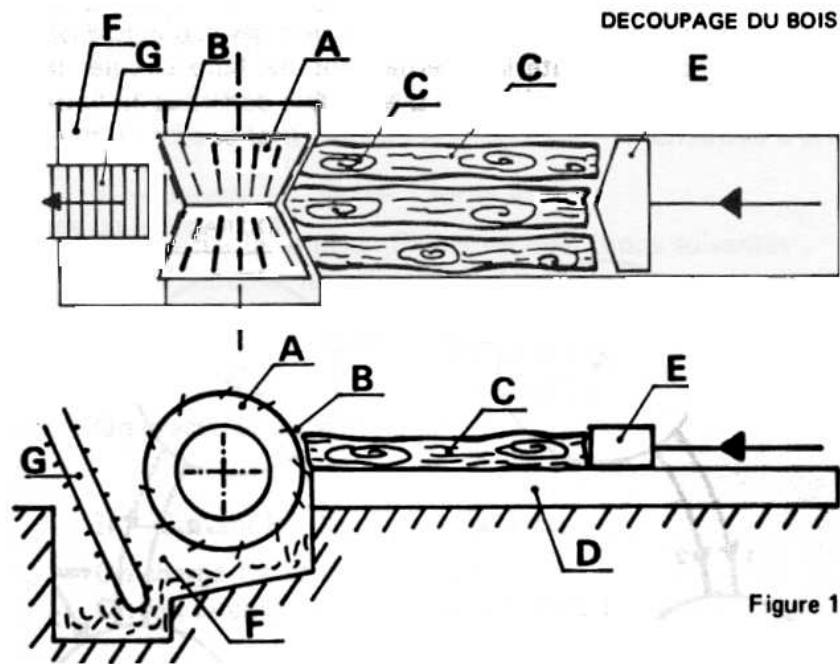

Figure 1: Découpage du bois pour l'extraction du tanin

Devant le tambour, on trouve un couloir (D) dans lequel sont placées les bûches à découper (C). Ces bûches sont poussées contre le tambour jusqu'à découpage complet par le poussoir (E). Les copeaux tombent dans une fosse (F) de laquelle ils sont transportés au-dessus de la batterie d'extraction par un élévateur (G).

Extraction :

L'extraction est conduite méthodiquement selon le principe du contre-courant de façon à extraire le maximum de tanin et à obtenir des solutions les plus concentrées possibles. Pour cela, les conditions de l'extraction sont telles que le bois le plus épuisé soit en contact avec la solution la moins concentrée et que le bois le plus riche soit en contact avec la solution la plus concentrée.

L'opération est réalisée dans une série d'autoclaves reliés par des tuyauteries permettant de faire circuler les solutions de l'un dans l'autre. L'ensemble constitue la batterie d'extraction.

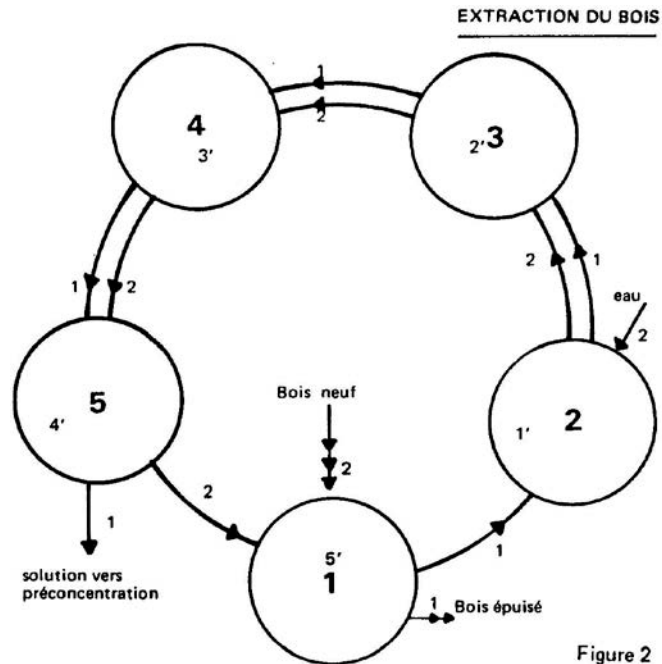

Figure 2: Schéma d'une série d'extracteurs en contre-courant

La température varie au cours de l'opération de 110 à 90 °C. Considérons une batterie de 5 autoclaves représentée schématiquement par la figure 2.

En ordre de marche, l'autoclave n° 5 renferme le bois le plus riche et la solution la plus concentrée. En 4-3-2 se trouve du bois de plus en plus épuisé au contact de solutions de plus en plus diluées. En 1 se trouve le bois le plus épuisé avec la solution la plus diluée.

La circulation des solutions, le déchargement et le chargement du bois se font en deux phases :

Suivant les flèches 1 du schéma, on évacue la solution 5 vers l'opération suivante, à savoir préconcentration et on fait circuler les solutions

4 dans 5

3 dans 4

2 dans 3

1 dans 2

on évacue le bois épuisé de 1.

Suivant les flèches 2 du schéma, on charge 1 avec du bois neuf. On fait circuler les solutions de

5 dans 1

4 dans 5

3 dans 4

2 dans 3

On envoie de l'eau chaude dans 2. On réchauffe chaque autoclave à une température convenable (110 à 90°C) par injection de vapeur.

Ainsi, pour se rapporter aux positions de départ :

1 est devenu 5' (bois le plus riche au contact de la solution la plus concentrée)

5 est devenu 4'

4 est devenu 3'

3 est devenu 2'

2 est devenu 1' (bois le plus épuisé au contact de la solution la moins concentrée)

Après 1 à 2 heures de contact, on recommence les mêmes mouvements des solutions, déchargement et chargement du bois. En 24 heures, 18 mouvements peuvent être effectués.

Préconcentration et décantation :

A la sortie de la batterie d'extraction, la solution récoltée appelée bouillon a une densité de 3° Baumé (Bé) environ ce qui correspond sensiblement à une concentration de 5 à 6 % de matières sèches. La température du bouillon est de 90°C. Cette solution est à peu près limpide. Par refroidissement, cette solution se trouble et laisse déposer des insolubles.

Si on poursuit les opérations, c'est à dire la concentration, on obtiendra un extrait qui, mis en solution par le tanneur, donnera des solutions riches en insolubles ce qui occasionnera quelques difficultés au moment du tannage. Il est donc nécessaire d'éliminer ces insolubles.

L'expérience a montré que la quantité d'insolubles décantables variait avec la concentration et la température en passant par un maximum pour une concentration comprise entre 10 et 12 % et une température entre 15 et 18°C.

Ainsi, pour obtenir l'élimination convenable des insolubles il faut :

- Amener la concentration des bouillons de 5-6 % à 10-12 %
- Refroidir les bouillons ainsi préconcentrés à 15-18°C
- Décanter et éliminer les insolubles formés

La préconcentration se fait au moyen d'appareils semblables à ceux utilisés pour la concentration décrite dans le paragraphe suivant. La solution sortant de la préconcentration a une teneur de 10-12 % de matières sèches et une température de 80-85°C. A partir de là, elle va parcourir le circuit représenté en figure 3. Il s'agit de refroidir cette solution et de la faire décanter. En même temps, la solution décantée et limpide est réchauffée pour être envoyée à la concentration.

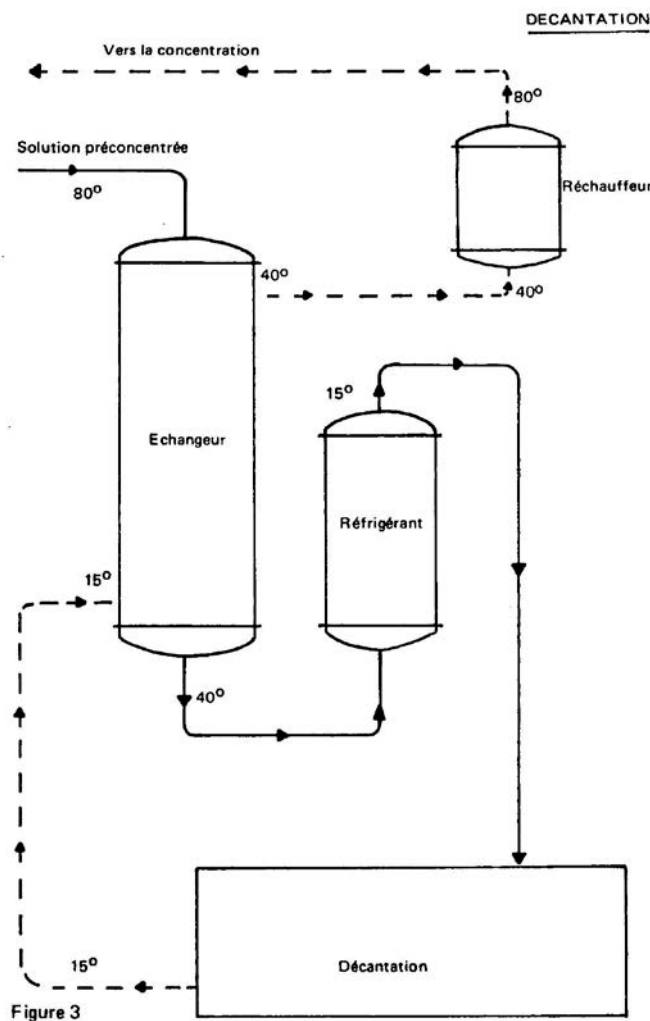

Figure 3: Schéma de décantation de la solution préconcentrée.

La solution préconcentrée traverse un échangeur dans lequel elle est refroidie par la solution décantée circulant en sens inverse. Ainsi, la solution préconcentrée se refroidit de 80 à 40°C, inversement la solution décantée se réchauffe de 15 à 40°C

La solution décantée passe ensuite dans un réchauffeur d'où elle sort à 80-85°C pour être envoyée à la concentration.

La solution préconcentrée traverse ensuite un réfrigérant d'où elle sort vers 15-18°C. Elle est alors envoyée dans des cuves où elle reste au repos 24 heures. Les insolubles tombent au fond sous forme de boue. Lorsque la solution limpide aura été renvoyée dans le circuit, la boue est pompée pour être introduite dans la batterie d'extraction au niveau de l'autoclave renfermant le bois le plus épuisé. Ainsi les insolubles sont retenus par les copeaux, les produits solubles passent dans les bouillons de la batterie d'extraction.

Concentration :

La concentration des solutions consiste à faire évaporer l'eau pour augmenter la teneur en matières sèches de la solution.

Dans une première phase, on atteint une concentration de l'ordre de 50 % de matières sèches (25° Bé). On obtient un extrait liquide. Pendant longtemps, les extraits furent livrés sous cette forme à la tannerie.

Dans une deuxième phase, on passe de l'extrait liquide à l'extrait sec, généralement en poudre, renfermant moins de 10 % d'eau.

L'évaporation de l'eau est conduite sous pression réduite et par conséquent à une température relativement basse (inférieure à 100°C) afin d'éviter l'hydrolyse et l'oxydation du tanin. Deux types d'appareils peuvent être utilisés pour cette opération : les évaporateurs à caisse verticale et les évaporateurs Kestner.

L'évaporateur à caisse verticale est composé essentiellement d'une cuve cylindrique surmonté d'un dôme également cylindrique. Dans la moitié inférieure de la cuve se trouve un faisceau tubulaire dans lequel est envoyée de la vapeur pour chauffer le liquide contenu dans l'appareil. Dans le dôme sont disposés des chicanes (brise mousse) pour empêcher les mousses formées par l'ébullition du liquide d'être entraînées dans le circuit vapeur.

Les appareils sont groupés en série de 3 ou 4. L'ensemble prend le nom de triple effet ou quadruple effet. Pour décrire le principe de fonctionnement de ces appareils, on étudiera le cas triple effet représenté sur la figure 4.

EVAPORATEUR A CAISSE VERTICALE

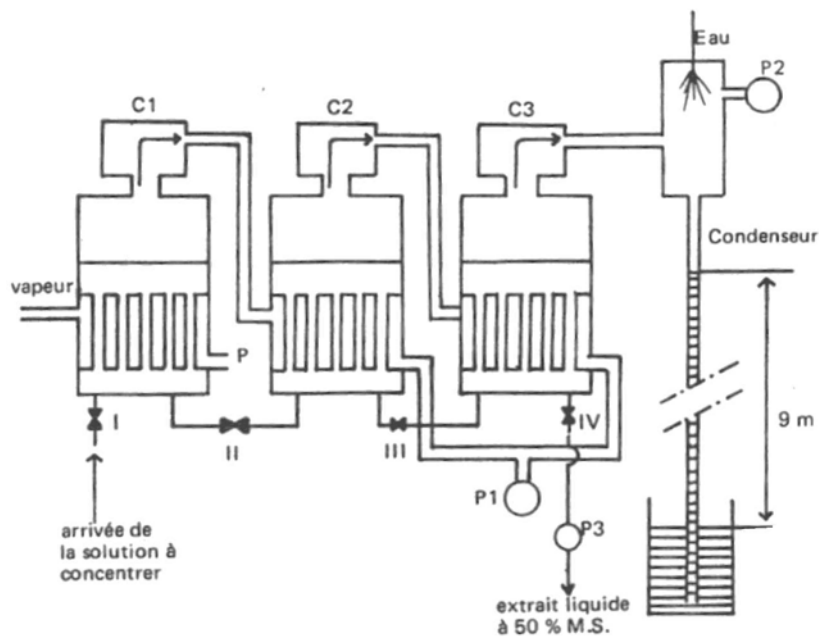

Figure 4: Schéma d'un évaporateur à caisse verticale

En ordre de marche, les caisses renferment des solutions de plus en plus concentrées de C1 à C3. Dans cette dernière, on obtiendra l'extrait liquide à environ 50 % de matières sèches, soit environ 25° Bé.

Le faisceau tubulaire de C1 est alimenté par de la vapeur basse pression provenant de la source de vapeur de l'usine. En chauffant la solution contenue dans C1, la vapeur se condense et l'eau condensée est évacuée en P dans le circuit général de purge. La solution entre en ébullition, la vapeur formée passe dans le faisceau tubulaire de C2. En chauffant la solution contenue dans C2, la vapeur se condense provoquant une dépression en C1. L'eau condensée dans le faisceau tubulaire de C2 est extraite par la pompe P1. La solution contenue dans C2 entre en ébullition, la vapeur formée passe dans le faisceau tubulaire de C3. En chauffant la solution contenue dans C3, la vapeur se condense provoquant une dépression en C2. L'eau condensée dans le faisceau tubulaire de C3 est extraite par la pompe P1. La solution contenue dans C3 entre en ébullition, la vapeur formée arrive dans le condenseur barométrique où elle se condense provoquant ainsi une dépression en C3. La pompe P2 est une pompe à vide qui maintient la dépression en éliminant les incondensables.

Ainsi s'établit un équilibre des conditions d'ébullition dans chaque appareil qui sont approximativement les suivantes :

Pour C1 : température d'ébullition 84°C, pression 0,56 bar (dépression 333 mm de mercure)

Pour C2 : température d'ébullition 70°C, pression 0,30 bar (dépression 540 mm de mercure)

Pour C3 : température d'ébullition 54°C, pression 0,15 bar (dépression 650 mm de mercure)

La solution à concentrer arrive dans C1 par la vanne I. Elle passe en C2 par la vanne II, en C3 par la vanne III et en IV on extrait la solution concentrée (extrait liquide à 50 % de matières sèches) au moyen d'une pompe P3, car il faut vaincre la dépression qui règne en C3.

Cette circulation se fait en continu, pour cela, on règle l'ouverture des vannes I, II, III et IV afin de maintenir le niveau de liquide à peu près constant dans les trois appareils.

L'évaporateur Kestner est très différent de la caisse verticale et son fonctionnement est basé sur le phénomène d'"ascension " des liquides.

Prenons un tube fermé à la partie inférieure, de faible diamètre et très long, enfermé dans une jaquette chauffante. On remplit ce tube jusqu'au tiers de sa hauteur environ avec la solution à concentrer. En chauffant, le liquide entre en ébullition, la vapeur d'eau formée s'élève à très grande vitesse, elle entraîne le liquide dans un mouvement ascendant, le plaquant en une mince pellicule contre la paroi du tube. Au fur et à mesure de l'ascension contre la paroi chaude, l'eau s'évapore et la solution qui arrive au sommet du tube est beaucoup plus concentrée que la solution de départ. Toute cette action se passe à grande vitesse et le rendement de l'évaporation est très élevé.

Un évaporateur Kestner est constitué d'un faisceau tubulaire de 7 mètres de hauteur enfermé dans une enceinte chauffée. La solution à concentrer est introduite à la base du faisceau. A la partie supérieure du faisceau arrive à grande vitesse la vapeur entraînant la solution concentrée. Pour séparer liquide et vapeur, le mélange passe dans un séparateur tangentiel pourvu à l'intérieur d'une chicane centrifuge. Le liquide est projeté sur la paroi et se rassemble au fond du séparateur, la vapeur s'échappe au centre par la partie supérieure. Ces appareils peuvent être groupés en multiples effets (voir figure 5). L'ensemble

fonctionne alors dans les mêmes conditions de température et de pression que les multiples effets à caisses verticales décrits précédemment.

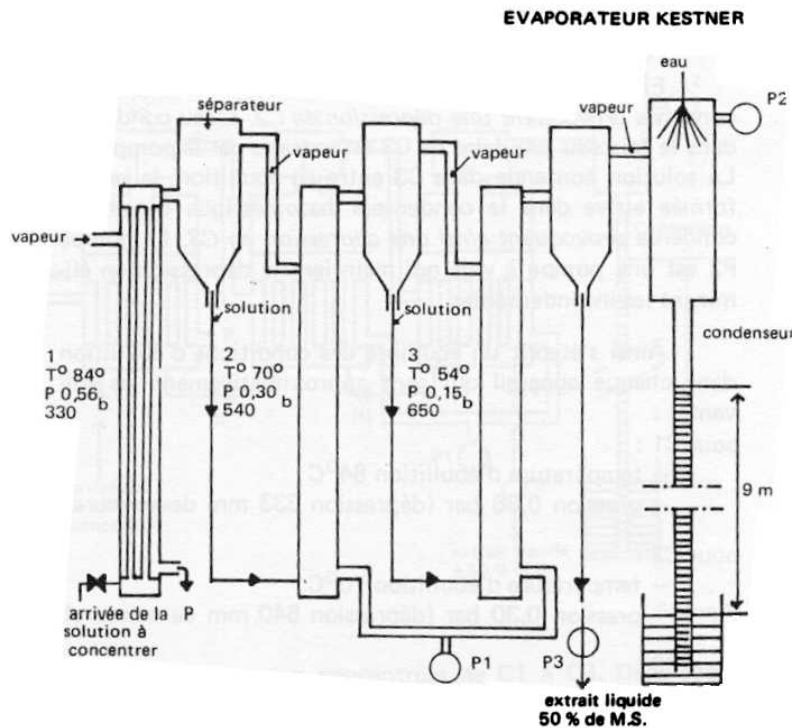

Figure 5 : Evaporateur de type Kestner

Obtention de l'extrait solide (poudre) :

Les extraits tannants ne sont que rarement livrés à l'état liquide mais le plus généralement à l'état d'extraits solides en poudre. Il s'agit donc de déshydrater l'extrait liquide obtenu précédemment.

Le moyen le plus répandu aujourd'hui est l'atomiseur. L'opération consiste à pulvériser l'extrait liquide sous forme de très fines gouttelettes (d'un brouillard) dans une enceinte traversée par un courant d'air chaud. L'eau s'évapore presque instantanément et les gouttelettes se transforment en poussière. Il suffit ensuite de séparer ces particules solides de l'air et de la vapeur d'eau.

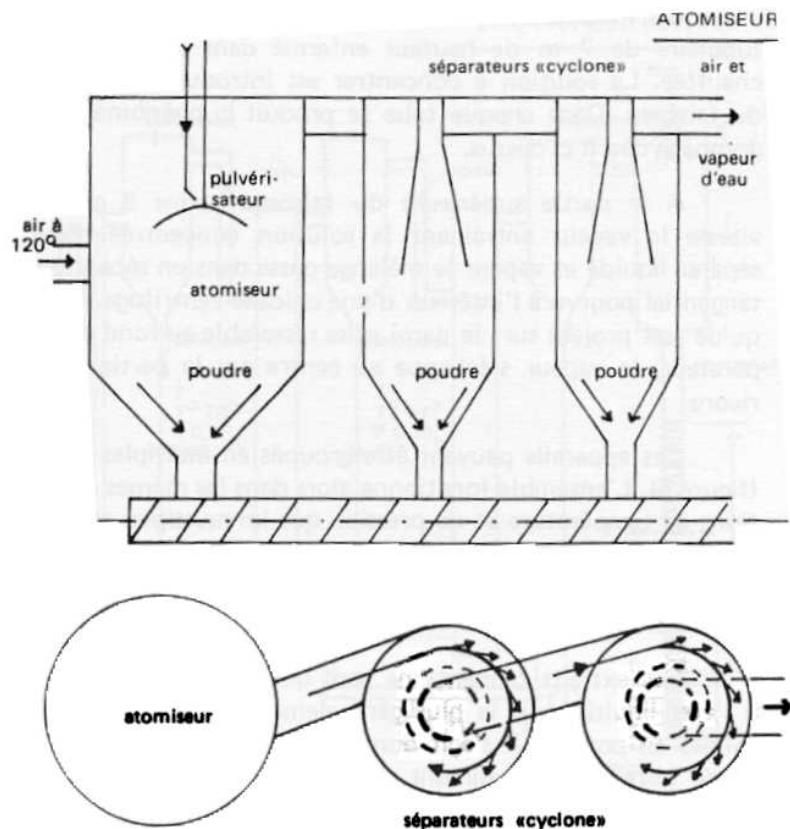

Figure 6 : Atomiseur

Schématiquement figure 6, l'installation comprend : une chambre cylindroconique (atomiseur), suivie de deux ou trois séparateurs tangentiels (cyclones). L'ensemble est traversé par un courant d'air chaud à 120°C.

La solution préalablement réchauffée est pulvérisée dans l'atomiseur, généralement par un dispositif mécanique. Les gouttelettes se transforment en particules solides, une petite partie se rassemble au fond de l'atomiseur, la plus grande partie est entraînée par l'air et la vapeur d'eau. Ce mélange passe dans les séparateurs tangentiels, les particules solides projetées contre la paroi tombent au fond des appareils, l'air et la vapeur d'eau s'échappent par la partie centrale vers le séparateur suivant, puis dans l'atmosphère. La poudre est alors évacuée vers l'ensachage.

Fabrication du tanin de Quebracho :

Le tanin de quebracho est extrait du bois d'un arbre (*Schinopsi Lorenzii* ou *Schinopsi balansae*) qui pousse naturellement dans la région agricole située entre le nord de l'Argentine et le sud du Paraguay.

Les arbres qui sont utilisés doivent être âgés d'environ 40 ans pour avoir un diamètre suffisant pour un usage industriel. Les arbres ne sont pas replantés à cause de leur long cycle de vie incompatible dans la gestion d'une entreprise et on utilise seulement les plantes qui poussent naturellement dans les régions indiquées.

Les troncs du quebracho sont abattus et écorcés dans les bois directement. On élimine également l'aubier, pauvre en tanin mais très attaché à l'écorce. Les troncs sont empilés et stockés en plein air quelques mois avant d'être extraits. Avant l'extraction, le bois est coupé en chips d'environ 1 cm et ensuite est chargé dans l'autoclave dans lequel l'extraction a lieu avec de l'eau à environ 130-135 °C. Ce tanin est extrait à une température sensiblement plus élevée que les précédentes du moment que le bois est beaucoup plus dur et a une densité plus élevée. L'extrait est concentré jusqu'à environ 50% de matière sèche. Il peut être sulfité dans le réacteur de sulfitation, en ajoutant du sulfite de sodium. L'extrait non sulfité a la particularité de ne pas être complètement soluble dans l'eau froide, en particulier à de faibles concentrations, en raison de la forte présence des phlobaphènes.

L'extrait concentré, et éventuellement sulfité, est ensuite envoyé à un atomiseur pour obtenir l'extrait en poudre.

La technique de séparation de l'extrait est sensiblement la même que celle décrite pour l'extrait de châtaignier. Cependant, pour le quebracho, il n'y a pas la phase de décantation.

L'extrait obtenu après évaporation à sec présente une propriété particulière : il n'est pas soluble dans l'eau froide (température ambiante). Il se dissout dans l'eau chaude à 80-100°C et par refroidissement la solution se trouble et après filtration on peut constater que le filtrat ne renferme qu'une faible quantité de tanin. Cet extrait s'appelle extrait de quebracho brut soluble à chaud. Sous cette forme, ce produit est difficilement utilisable dans les méthodes de tannage classiques où l'on opère à température ambiante ou au maximum à 30°C.

Il est donc nécessaire de solubiliser l'extrait brut. C'est en 1897 que Lepetit, Dolfus et Gansser ont breveté un procédé dit de sulfitation permettant d'atteindre ce but. On traite une solution concentrée (50 % de matières sèches) d'extrait de quebracho brut par de l'hydrogénosulfite de sodium (bisulfite de sodium NaHSO_3) à chaud sous pression en autoclave. Après ce traitement, on obtient un produit parfaitement soluble dans l'eau froide. Après évaporation à sec, on se trouve en présence de l'extrait de quebracho sulfité soluble à froid. L'extrait de quebracho sulfité est un tanin doux. Il pénètre rapidement dans la peau en tripe, le cuir obtenu n'a pas un indice de tannage élevé, il est souple, de couleur claire. En modérant le traitement de sulfitation, généralement en diminuant la proportion d'hydrogénosulfite de sodium, on n'obtient qu'une solubilisation partielle. On prépare ainsi l'extrait de quebracho mi-soluble dont les solutions, troubles à froid, renferment un fort pourcentage de tanin soluble. Ce genre de produit est utilisé en particulier pour le retannage de certains cuirs au chrome pour lesquels on recherche un effet de remplissage important.

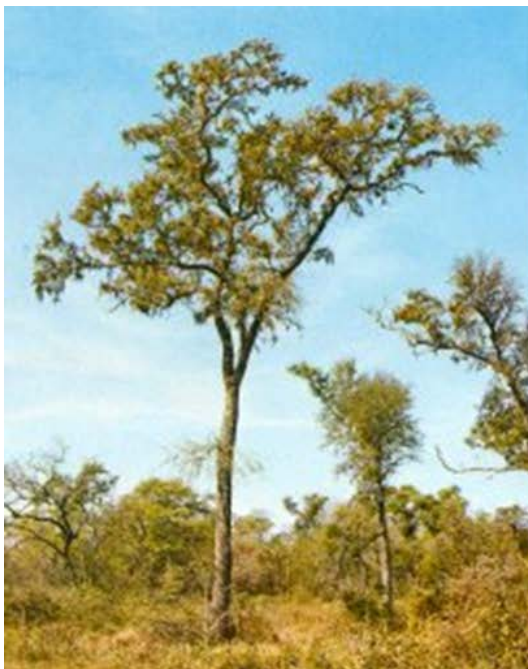

Fabrication du tanin de Mimosa :

Le tanin de mimosa est extrait de l'écorce de l'Acacia mearnsii (également appelé acacia noir ou mimosa), qui est cultivé principalement au Brésil et en Afrique du Sud pour la production de bois et pour l'extraction des tanins.

Dans ces régions, il y a des plantations de centaines de milliers d'hectares, gérées avec le seul but de produire du bois et des tanins.

L'écorce est séparée du tronc des arbres d'environ 7 ans immédiatement avant de couper les plantes. En 24 heures, l'écorce est réduite en morceaux et extraite. L'extraction a lieu dans des autoclaves en série à travers lesquels on fait un lavage à contre-courant avec de l'eau ou de l'eau avec un petit pourcentage de sulfite de sodium, selon si on veut produire un extrait naturel ou un extrait sulfité. L'extrait non sulfité a la particularité de ne pas être complètement soluble dans l'eau froide, en particulier à de faibles concentrations, en raison de la présence des phlobaphènes.

L'extrait aqueux est concentré jusqu'à environ 50% de matière sèche et envoyé à un atomiseur qui donne l'extrait en poudre.

L'extrait de mimosa est préparé à partir de l'écorce de l'arbre. La technique est semblable à celle décrite pour la préparation de l'extrait de bois de châtaignier. Il n'y a pas de phase de décantation proprement dite, le tanin étant soluble à toutes les températures. Comme les autres extraits tannants, les produits commerciaux sont généralement présentés sous forme d'extrait poudre atomisé. C'est un tanin doux qui pénètre rapidement dans la peau en tripe et s'y fixe en quantité plus importante que ne le fait le quebracho. Le cuir obtenu est de couleur claire, moins rose que celui obtenu avec le quebracho, l'indice de tannage est relativement élevé.



Classification générale des tanins:

Du point de vue de la composition chimique, on distingue deux grandes familles de tanins: les tanins hydrolysables et les tanins condensés ou flavonoïdes.

Tanins hydrolysables:

Les tanins hydrolysables sont constitués de produits phénoliques simples: ce sont des esters d'acide gallique et de ses dimères (acide digallique, acide ellagique) et de monosaccharides (surtout le glucose). Les tanins hydrolysables sont souvent divisés en gallotanins, conduisant à de l'acide gallique après hydrolyse ou en ellagitanins libérant de l'acide ellagique après hydrolyse [Jurd, 1962].

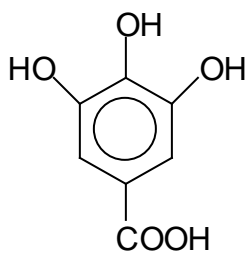

Acide gallique

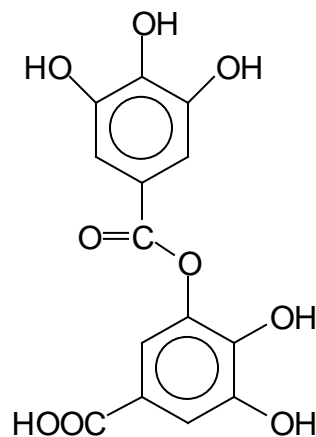

Acide digallique

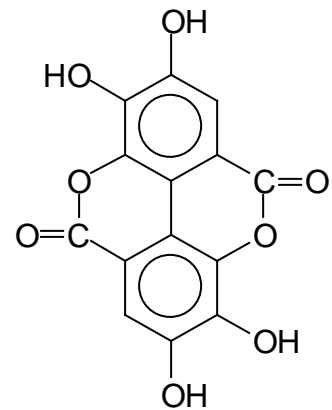

Acide ellagique

Figure 7: Différents types de tanins hydrolysables

Ils ont déjà été utilisés comme substituts partiels du phénol dans la fabrication de résines phénol formaldéhyde [Kulvik, 1976 ; 1977], néanmoins leur utilisation reste des plus limitées dans le domaine des colles du fait de leur basse réactivité avec le formaldéhyde. Au contraire, l'utilisation des tanins de châtaignier et de Tara est importante dans l'industrie du tannage.

Tanins condensés :

Les tanins condensés sont constitués d'unités flavonoïdes. Présentant différents degrés de polymérisation, ils sont associés à leurs précurseurs : catéchines (flavanes-3-ols), leucoanthocyanes (flavanes-3,4-diols) [Drewes et Roux, 1963 ; Roux et Paulus, 1961] et à des carbohydrates dont la plus ou moins grande proportion influence la viscosité et la réactivité du tanin.

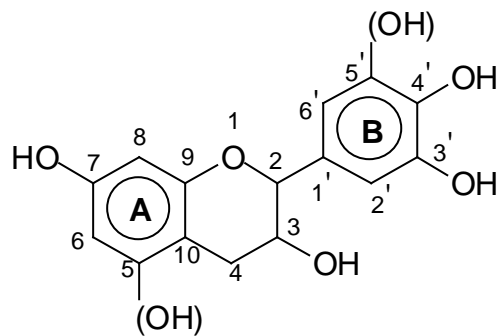

Figure 8: Schéma d'un flavonoïde et sa numérotation

Comme le montre le schéma précédent (fig.8), il est possible d'obtenir deux types d'anneau A et deux types d'anneau B :

- Anneau A avec un seul groupe hydroxyle en C7 : anneau résorcinol
- Anneau A avec deux groupes hydroxyles en C5 et C7 : anneau phloroglucinol
- Anneau B avec deux groupes hydroxyles en C3' et C4' : anneau catéchol
- Anneau B avec trois groupes hydroxyles en C3', C4' et C5' : anneau pyrogallol

A partir de ces différents types d'anneaux, il a été défini une nomenclature des polyflavonoïdes [Porter, 1988] :

Anneau A type phloroglucinol et anneau B type pyrogallol : prodelphinidine (l'élément de base est la gallocatéchine)

Anneau A type phloroglucinol et anneau B type catéchol : procyanidine (l'élément de base est la catéchine)

Anneau A type résorcinol et anneau B type pyrogallol : prorobinetidine (l'élément de base est le robinetinidol)

Anneau A type résorcinol et anneau B type catéchol : profisetidine (l'élément de base est le fisetinidol)

Les tanins condensés sont toujours constitués d'un mélange aux proportions diverses des quatre types de polyflavonoïdes définis ci-dessus. Ainsi pour le type d'anneau A, la fréquence d'anneau de type phloroglucinol vis à vis du type résorcinol permet de déterminer la réactivité du tanin vis à vis d'un aldéhyde et de présager de la qualité du réseau d'enchevêtrement. Pour l'anneau B, la fréquence des anneaux de type pyrogallol vis à vis de ceux de type catéchol influe sur l'ouverture de l'hétérocycle pyranique et détermine le type de réarrangement à envisager pour la structure sous conditions alcalines ou basiques [Pizzi et Stephanou, 1994 (1), (2)].

Une technique d'analyse C^{13} RMN des tanins condensés a permis de mettre en évidence les types de polyflavonoïdes rencontrés pour un tanin déterminé. Néanmoins cette méthode ne permet pas de différencier les prodelphinidines des procyanidines, ni les prorobinetinidines des profisetinidines [Thompson et Pizzi, 1995]. C'est la raison pour laquelle on compare (prodelphinidines + procyanidines) à (prorobinetinidines + profisetinidines).

D'après Roux et al. en 1975, seuls les flavonoïdes de type flavan-3-ol et flavan-3,4-diol participent à la formation des tanins condensés. En effet, le groupe carboxyle en position 4 des autres types de flavonoïdes réduit le caractère nucléophile et occupe une des positions de condensation. La substitution méta de l'anneau A de type résorcinol des flavan-3,4-diols par les groupes hydroxyles et l'oxygène de l'hétérocycle crée une très forte nucléophilie pour les positions C6 et C8. Ainsi, les unités des tanins condensés sont principalement liées par des liaisons 4-6 et 4-8. La première étape de réaction de condensation est la formation de proanthocyanidines dimères appelés aussi biflavonoïdes.

On parle réellement de tanins condensés pour une répétition de 3 à 8 unités de flavonoïdes. De nombreuses études ont été réalisées sur l'utilisation de ces tanins condensés [Roux, 1972 ; Roux et al, 1975 et 1976 ; Pizzi, 1980].

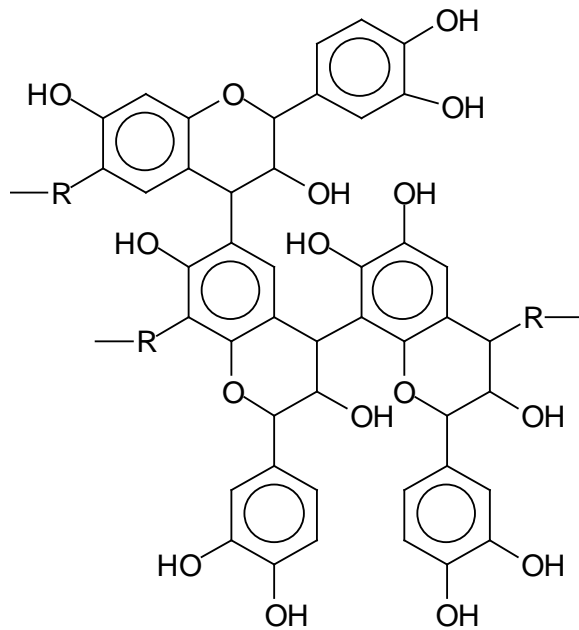

Figure 9: Exemple de réticulation de trois flavonoïdes

Il a été montré qu'il existait des réactions radicalaires d'autocondensation des tanins polyflavonoïdes conduisant à la formation et au durcissement d'un réseau d'enchevêtrement sans addition d'aldéhyde mais en présence de bases ou d'acides faibles de Lewis [Meikleham et al., 1994 ; Pizzi et al., 1995 (1); Pizzi et Meikleham, 1995 ; Merlin et Pizzi, 1996 ; Masson et al., 1996 (1), (2) ; Masson et al., 1997 (3)]. Une résine est ainsi formée, qui ne dégage pas de formaldéhyde libre mais qui est néanmoins utilisable uniquement en intérieur [Pizzi et al., 1995 (2) ; Pizzi, 1994]. L'analyse thermomécanique en flexion trois points a permis de quantifier l'enchevêtrement du réseau par détermination du nombre moyen de degré de liberté des segments de polymères au cours de l'autocondensation des tanins [Garcia et Pizzi, 1998, (1)]. Dans l'analyse des thermogrammes obtenus, l'augmentation du module d'Young est liée à deux phénomènes : la progression de la réaction d'autocondensation du tanin par paliers successifs correspondant aux différences de réactivités des sites disponibles sur l'anneau A et l'anneau B mais aussi l'autocondensation à basse température initiale qui conduit à la formation de polymères linéaires dont la longueur augmente jusqu'à une valeur limite qui dépend de la température et de la concentration, longueur critique à partir de laquelle se forme un réseau d'enchevêtrement de ces polymères linéaires qui correspond à un autre palier sur la courbe du Module d'Young [Garcia et Pizzi, 1998, (2)]. Dans le cadre de

résines de type phénol - formaldéhyde, l'analyse TMA a permis de mettre en évidence le point de gel, correspondant au début de l'augmentation du module d'Young et le début de la vitrification de la résine correspondant au point d'inflexion de la courbe du module [Yin et al, 1995 ; Riesen et Sommerauer, 1983 ; Hofmann et Glasser, 1990]. Dans le cas des tanins condensés qui sont des composés phénoliques complexes, il n'est pas possible de définir ces deux concepts puisque la courbe du module d'Young comporte plusieurs pics et plusieurs paliers. Ainsi, on identifiera les différents points d'inflexion obtenus, à savoir les pics de la dérivée première du module, suivant leur ordre d'apparition: le premier point d'inflexion est identifié comme le début de l'enchevêtrement des polymères linéaires, sorte de pseudovitrification , suivi par le vrai début de la vitrification due à la formation du réseau d'enchevêtrement tridimensionnel induit par la réactivité des sites de l'anneau A et enfin le renforcement du réseau précédemment formé par réactions sur les sites de l'anneau B [Garcia et Pizzi, 1998, (2)].

En considérant les mécanismes réactionnels radicalaires, on connaît la capacité des phénols à produire des radicaux phénoxyles (de type $\Phi-O^*$) plutôt stables qui sont capables de retarder ou d'inhiber la progression de la polymérisation radicalaire des tanins [Allcock et Lampe, 1990 ; Seymour et Carraher, 1992]. Il est donc intéressant, en se basant sur les connaissances issues de l'étude des finitions pour la protection du bois, de considérer les capacités antioxydantes des tanins, propriété évaluée par l'aptitude à former rapidement ou non des radicaux, soit par transfert de radicaux préexistants chez les tanins comme nous venons de le voir vers un radical phénoxy plus stable, soit par action de l'irradiation lumineuse sur le tanin mais propriété également évaluée par la vitesse de disparition des radicaux phénoxyles formés. Cette étude a été menée par Spectroscopie de Résonance Paramagnétique Electronique et a permis de déterminer dans le cas de l'étude des tanins, quatre paramètres classés par ordre décroissant d'importance qui influent sur les capacités antioxydantes des tanins, à savoir :

- L'état colloïdal de la solution de tanin, lié à la présence de carbohydrates [Masson et al., 1996 (1) ; (2)]
- La stéréochimie des tanins étudiés liée à la facilité de formation des liaisons interflavonoïdes [Zalacain et al., 2002]

- La facilité d'ouverture de l'hétérocycle pyranique
- Le nombre de groupes hydroxyles présents sur l'anneau A et l'anneau B du tanin

Ainsi, on peut en déduire que les tanins condensés possèdent des propriétés antioxydantes incontestablement supérieures aux tanins hydrolysables et que le tanin de quebracho est un meilleur antioxydant que le tanin de mimosa [Noferi et al., 1997].

Diverses techniques d'analyse ont également permis d'isoler et d'identifier les molécules constituant les tanins ainsi que leur degré de polymérisation par chromatographie liquide haute performance [Cheynier et al., 1999], par chromatographie à perméation de gel [Cadahía et al., 1996]. La spectroscopie d'absorption de l'ultraviolet [Kirby et al, 1953 ; Muralidharan, 1997] permet d'identifier globalement la famille d'un tanin alors que la spectroscopie infrarouge à transformée de Fourier permet de définir un tanin donné [Nakagawa et Sugita, 1999]. La spectroscopie du proche infrarouge a également aidé à analyser un extrait de tanin, en déterminant la part d'extractibles, de tanins et de non tanins pour une espèce de tanin donnée [Donkin et Pearce, 1995].

Ces dernières années, une technique innovante s'est développée. Il s'agit de la spectrométrie de masse couplant une source d'ionisation laser assistée par une matrice et un analyseur à temps de vol ou MALDI-ToF qui permet d'évaluer le poids moléculaire des fragments de polymère. L'introduction de cette technique dans l'investigation des tanins [Pasch et al., 2001] a permis une connaissance encore supérieure sur les enchaînements des flavonoïdes dans le polymère tannique.

Les tanins condensés sont beaucoup plus intéressants dans la chimie des adhésifs car ils réagissent de la même façon que les phénols sur des durcisseurs comme les aldéhydes en milieu acide ou basique.

Les réactions de polycondensation des tanins sont connues seulement depuis 1952 grâce à McLean et Gardner pour des utilisations dans les adhésifs pour bois. Plus récemment, l'utilisation des tanins s'est développée et a trouvé des applications dans le collage du bois, de carton ondulé et de différents types de

panneaux de particules, OSB et contreplaqué au point que les formulations sont déjà devenues commerciales.

En résumé, il est possible de classer les principaux extraits de tanins condensés en précisant le polyflavonoïde dominant, le type d'enchaînement et le degré de polymérisation qui reflète le nombre moyen des unités dans l'oligomère:





Extrait	Type de flavonoides	Enchainement	Degré de polymérisation	Aspect
Mimosa (<i>Acacia Mearnsii</i> or <i>mollissima</i>)	prorobinetidine	4-6	Elevé	
Quebracho (<i>Schinopsis Balansae</i>)	profisetidine	4-6	Elevé	
Pine (<i>Pinus Radiata</i>)	procyanidine	4-8	Très Elevé	
Pecan (<i>Carya Illinoensis</i>)	procyanidine	4-8	Très Elevé	
Gambier (<i>Uncaria Gambir</i>)	procyanidine	4-8	Bas	

Tableau 2: Classification des différents types de tanins condensés.

Réactivité des tanins condensés :

La relative accessibilité et/ou réactivité des flavonoïdes a été étudiée grâce à la bromation sélective dans la pyridine de modèles des familles du phloroglucinol et du résorcinol. On peut alors observer la bromation préférentielle de la (+)-tétra-O-méthylcatéchine en C8 [Roux *et al*, 1975], et c'est uniquement lorsque ce site est occupé que la substitution commence en C6. Le noyau B n'est pas réactif à moins qu'il n'y ait un excès de réactif de bromation : on observe alors un faible degré de substitution en C6'. La séquence de bromation de la (+)-tétra-O-méthylcatéchine ($8 > 6 > 6'$) est présentée sur la figure (10 A).

Cependant, pour le résorcinol équivalent, la (-)-tri-O-méthylfustine, la séquence de substitution devient $6 > 8 > 6'$ (10 B).

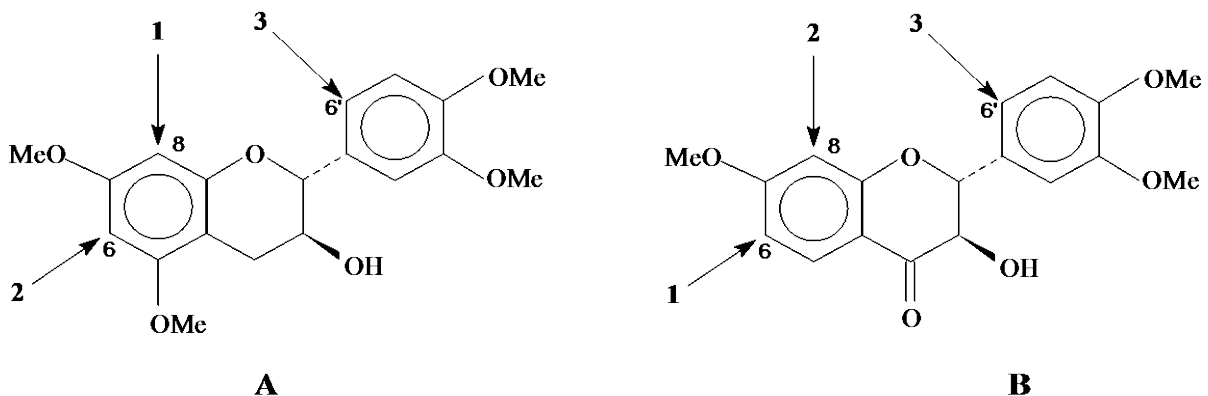

Figure 10: Représentation des sites réactifs des flavonoïdes par bromation

La substitution préférentielle des flavonoïdes de type phloroglucinol en C8 et de type résorcinol en C6 doit vraisemblablement être liée à la plus grande accessibilité de ces sites. En utilisant le résorcinol comme modèle simplifié, il apparaît que les di-, tri- et tétramères formés lors de la réaction (en milieu acide ou alcalin) de celui-ci avec le formaldéhyde, ne privilégient pas la position en *ortho* des deux groupements hydroxyles. Cette substitution préférentielle qui semble être respectée dans la structure des biflavonoïdes, et confirmée par les réactions de modèles phénoliques, n'est cependant pas respectée à un degré de réticulation supérieur.

Réaction avec les aldéhydes

Les tanins étant de nature phénolique, ils réagissent de la même manière que les phénols, aussi bien en milieu acide qu'en milieu alcalin. L'augmentation de l'alcalinité du milieu augmente la nucléophilie du phénol, tout spécialement vers pH=8 où des ions phénates sont formés. Les sites nucléophiles présents sur le noyau A de n'importe quel flavonoïde tendent à être plus réactifs que ceux du noyau B. Ceci est dû aux groupements vicinaux hydroxyyles qui provoquent une activation de la globalité du noyau B sans localisation de la réactivité comme cela se produit sur le noyau A.

Le formaldéhyde réagit avec les tanins lors d'une polymérisation faisant intervenir des ponts de type méthylène entre les sites réactifs des flavonoïdes, principalement ceux des noyaux A.

Dans les molécules de tanins condensés, seul subsiste un site hautement réactif, l'autre étant engagé dans une liaison interflavonoïde. Les flavonoïdes à noyaux A de type résorcinol (tanins de Mimosa) montrent une réactivité vis-à-vis du formaldéhyde comparable, ou légèrement inférieure, à celle de la résorcine [Rossouw et al, 1980 ; Pizzi, 1978]. Les noyaux B de type pyrogallol ou catéchol ne sont donc pas réactifs, sauf lorsqu'il y a formation d'anions à des pH relativement élevés (≈ 10) [Roux et al, 1975]. Parfois, les noyaux B de type catéchol sont réactifs à température plus élevée [Osman and Pizzi, 2002]. Malheureusement la réactivité des noyaux A vis-à-vis du formaldéhyde est alors tellement élevée que la trop faible durée de conservation des résols tanins-formaldéhyde les rend industriellement inutilisables [Pizzi, 1978].

En pratique, seuls les noyaux A interviennent dans la formation du réseau tridimensionnel. Cependant, il suffit d'un faible degré de condensation avec le formaldéhyde pour que la taille et la configuration des molécules de tanins leur imposent l'immobilité, ceci à un point tel que les sites réactifs sont alors trop éloignés pour que puisse s'établir un pont de type méthylène [Roux et al, 1975]. Le résultat en est une polymérisation incomplète, d'où les faiblesses et les fragilisations souvent caractéristiques des adhésifs tanins-formaldéhyde. Cependant, certaines indications suggèrent que dans des milieux légèrement acides ou basiques avec un excès de résorcinol, les noyaux B de type pyrogallol sont capables de réagir avec le formaldéhyde [Pizzi, 1977]. Ainsi, lors de l'étude

de molécules modèles à température ambiante, Pizzi a observé la formation de dimères pyrogallol-formaldéhyde, ainsi que de dimères et de trimères résorcinol-formaldéhyde. Ceci indique qu'en dépit d'une participation limitée des noyaux B dans la formation d'un réseau tridimensionnel tanin-formaldéhyde, un tel réseau reste toujours faible.

Afin de résoudre ce problème, des agents de réticulation comme des résines phénoliques ou aminoplastiques à fort taux de polymérisation ont été utilisées, elles permettent l'établissement de liaisons entre des sites trop distants pour être reliés par un pont de type méthylène [Pizzi et Scharfetter, 1978; Pizzi et Roux, 1978].

Bien que le catéchol et les noyaux B de type catéchol ne réagissent pas avec le formaldéhyde à des pH inférieurs à 10, l'addition d'acétate de zinc permet aux noyaux B de type catéchol de réagir avec le formaldéhyde à ces pH, la gamme optimale de pH étant 4,5-5,5, comme le montre la plus grande quantité de formaldéhyde consommée [Hillis et Urbach, 1959]. L'acétate de zinc permet donc une réticulation du système sans employer de résines synthétiques phénoliques ou aminoplastiques. Ainsi l'utilisation d'une petite quantité d'acétate de zinc (5 à 10% par rapport à la résine solide) permet d'obtenir un degré de réticulation élevé ne conférant cependant pas au réseau une force comparable à celle obtenue grâce à l'addition de résines synthétiques [Osman and Pizzi, 2002].

Si l'on considère la dépendance de la réaction tanins-formaldéhyde vis-à-vis du pH, il est généralement reconnu que la réaction des tanins de Mimosa avec le formaldéhyde est plus lente entre 4.0 et 4.5 et, pour les tanins de Pin, entre 3.3 et 3.9. La quantité de formaldéhyde réagissant avec ces tanins, dans ces domaines de pH, est tout naturellement la plus faible [Plomley, 1966].

A pH neutre, le formaldéhyde réagit rapidement avec les unités monomères en C6 et C8, mais également en C2' et C6' des noyaux B de type catéchol ou pyrogallol bien que plus lentement. La figure 1 dans [Pizzi, 1980], montre la dépendance du temps de gel du tanin de Mimosa avec le formaldéhyde en fonction du pH à 100°C.

Le formaldéhyde est l'aldéhyde généralement utilisé lors de la préparation et du durcissement d'adhésifs à base de tanins. Il est normalement additionné aux tanins en solution, au pH désiré, sous la forme de formaline liquide ou sous la forme du paraformaldéhyde polymère, capable de se dépolymériser rapidement en milieu alcalin.

L'hexaméthylènetétramine (hexamine) peut également être utilisée; elle se décompose en effet, dès 65°C, en formaldéhyde. L'hexamine instable en milieu moyennement acide devient plus stable lorsque le pH augmente. Cependant, en milieu alcalin, la libération de formaldéhyde peut ne pas être aussi rapide et efficace que décrite par [Saayman, 1971].

En milieu acide, l'hexamine (soluble dans l'eau jusqu'à 50% en masse) se décompose en 6 molécules de formaldéhyde et 4 molécules d'ammoniaque. En milieu alcalin, seules 3 molécules de formaldéhyde sont libérées, accompagnées par la formation de triméthylamine. Ainsi, en milieu alcalin, l'hexamine ne libérant du formaldéhyde qu'à partir de 65°C, les solutions d'hexamine et de tanins de Mimosa ont une durée de vie en pot très importante à température ambiante [Pizzi, 1977]. Il a cependant déjà été rapporté que les réseaux formés lors de l'utilisation de l'hexamine comme durcisseur ne résistent pas à l'eau bouillante [Saayman, 1971], contrairement à ceux formés lors de l'utilisation de la formaline ou du paraformaldéhyde. L'ammoniaque libérée serait responsable de cette faiblesse. Quelques auteurs [Pizzi, 1977; McLean et Gardner, 1952] ont montré que la présence d'hexamine permettait l'existence de liaisons aussi solides, si ce n'est plus, que celles obtenues en présence de paraformaldéhyde, mais seulement en milieu alcalin; ceci peut être attribué à la formation de triméthylamine et non d'ammoniaque avec moins de dommages au réseau formé.

La réaction du formaldéhyde avec les tanins peut être contrôlée par addition d'alcool, une partie du formaldéhyde est alors stabilisée par formation d'hémiacétals, par exemple $\text{CH}_2(\text{OH})(\text{OCH}_3)$, si l'on utilise le méthanol [Scharfetter et al, 1977]. Lorsque l'adhésif est durci (en augmentant la température), l'alcool est libéré à vitesse constante et le formaldéhyde, progressivement reformé à partir des hémiacétals, s'évapore moins qu'en absence d'alcool. La présence de celui-ci permet donc de rendre le formaldéhyde non réactif, ce qui a pour conséquence d'augmenter la durée de vie en pot de tels adhésifs.

Si l'on ne perd pas de vue le fait que les sites réactifs sont parfois trop éloignés les uns des autres pour permettre l'établissement de ponts de type méthylène, et ainsi la création d'un réseau optimum, d'autres aldéhydes, mais cette fois-ci à caractère bifonctionnel, peuvent être utilisés comme substituts du formaldéhyde. Parmi eux, l'un des plus fréquemment employés est le furaldéhyde. Bien qu'il

réagisse lentement avec les phénols [Plomley, 1966], le furaldéhyde se révèle être, lorsqu'il est utilisé conjointement avec le formaldéhyde, un agent de réticulation efficace et un excellent plastifiant pour les adhésifs à base de tanins [Pizzi, 1978].

Le glutaraldéhyde réagit quant à lui avec les tanins en formant un précipité mais beaucoup plus lentement que le formaldéhyde. Les cinétiques de réaction du formaldéhyde, de l'acétaldéhyde, du propionaldéhyde, de l'iso-butyraldéhyde et du furaldéhyde avec les tanins condensés de type résorcinol et phloroglucinol ont été étudiées [Rossouw, 1979]. Les mêmes études ont été menées sur des modèles simples, à savoir : le résorcinol, le phloroglucinol et le catéchol. Les tanins sont également capables de réagir avec le benzaldéhyde et le glyoxal. Des différences notables ont été observées dans les vitesses de réaction des tanins de type résorcinol et phloroglucinol avec divers aldéhydes. Dans le cas des tanins de type phloroglucinol, les vitesses de réaction se classent ainsi:

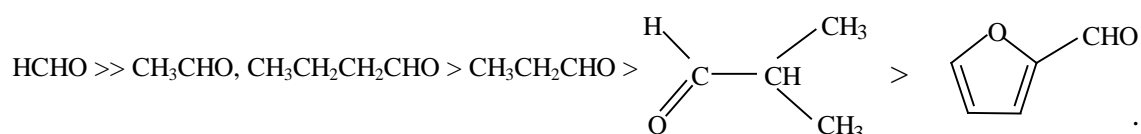

Pour les flavanoïdes de type résorcinol, l'échelle de réactivité est la suivante:

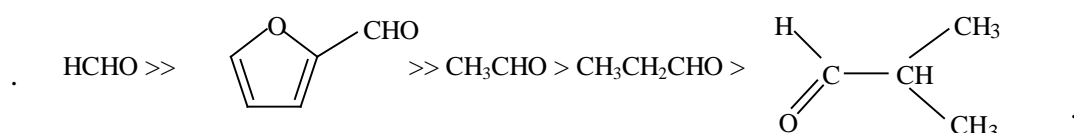

Entre ces deux échelles de réactivité, la plus grande différence est la position du furaldéhyde. Si sa réactivité vis-à-vis des réactifs phénoliques et des flavonoïdes possédant un noyau A de type résorcinol est importante, elle est fortement limitée par des problèmes d'encombrement stérique dans le cas des flavonoïdes ayant un noyau A de type phloroglucinol. Dans le cas des flavonoïdes de type résorcinol, l'attaque de l'aldéhyde a lieu en C8 (11 A), site considérablement moins encombré stériquement que le site C6 des flavonoïdes de type phloroglucinol (11 B).

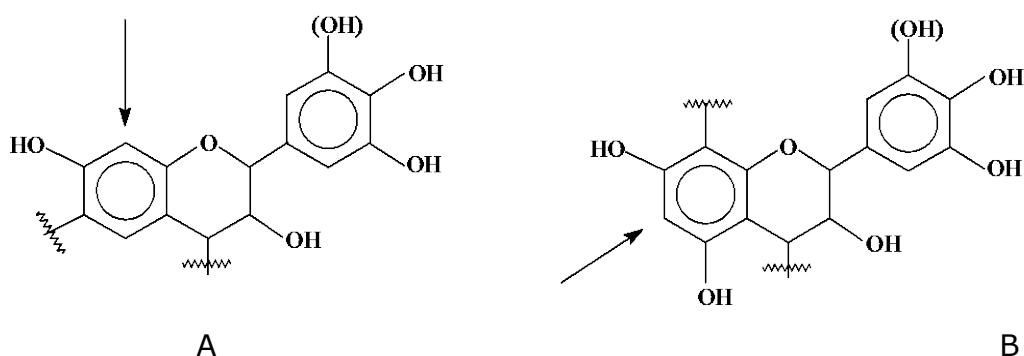

Figure 11. Sites d'attaque du formaldéhyde sur des flavonoïdes de type résorcinol (A) et de type phloroglucinol (B)

Un comportement similaire peut également être observé lorsque le phloroglucinol et le résorcinol sont utilisés comme modèles dans cette réaction. La position du furaldéhyde, dans l'échelle de réactivité avec ces deux phénols, est également dépendante de considérations stériques, sa réactivité est plus importante dans le cas du résorcinol que dans le cas du phloroglucinol [Rossouw, 1979].

La réaction des tanins avec les aldéhydes, en milieu alcalin, suit une loi cinétique du second ordre dans laquelle la vitesse est la suivante:

$$\text{Vitesse} = k_1[\text{aldéhyde}] [\text{tanin-OH}] + k_2[\text{aldéhyde}] [\text{tanin-O}^-] \quad (1)$$

avec:

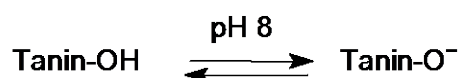

A des pH supérieurs à 8.2, la réactivité est essentiellement due aux tannates formés. Le second terme de l'équation ci-dessus (k_2) l'emporte donc devant le premier, considéré comme négligeable. A l'inverse, à des pH inférieurs à 7.9, c'est le deuxième terme qui est considéré comme négligeable. En conséquence l'équation (1) peut-être subdivisée en deux équations (2) et (3), en fonction du pH:

$$\text{Vitesse} = k_1[\text{aldéhyde}] [\text{tanin-OH}] \quad \text{pH} < 7.9 \quad (2)$$

$$\text{Vitesse} = k_2[\text{aldéhyde}] [\text{tanin-O}^-] \quad \text{pH} > 8.2 \quad (3)$$

La réaction des aldéhydes avec les produits de la réaction tanins/formaldéhyde suit également une loi cinétique du second ordre:

$$\text{Vitesse} = [\text{aldéhyde}] \sum_n k_n [(-\text{CH}_2\text{-tanin-})_n] \quad (4)$$

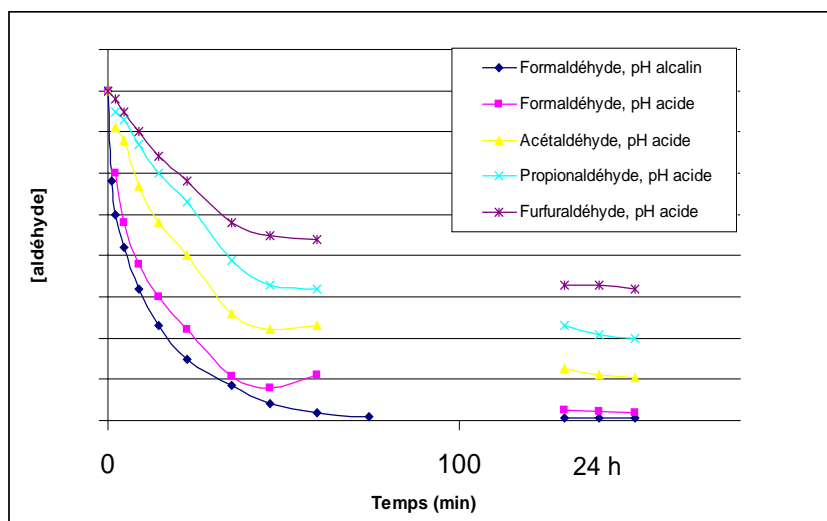

Figure 12 : Représentation schématique de la consommation d'aldéhydes en présence de tanin de Mimosa.

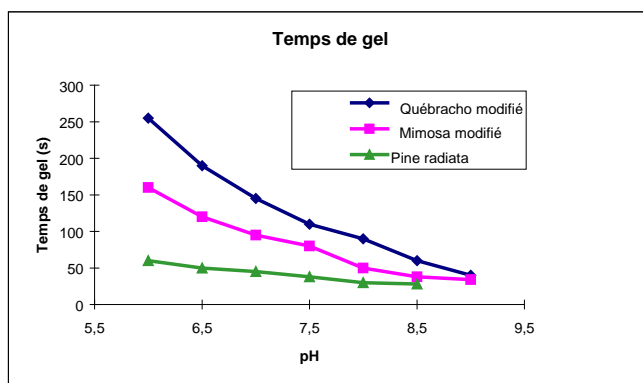

Figure 13 : Temps de gel tanin/paraformaldéhyde en fonction du pH [Pizzi, 1994].

La figure 13 nous donne un aperçu de la cinétique de consommation du formaldéhyde en présence de tanins de Mimosa. La partie initiale de la courbe est la somme des équations (1) et (4). La partie terminale correspond à la seule

équation (4). Dans l'équation (1), les termes dépendant de la concentration en tanins hydroxyméthylés, obtenus après l'attaque initiale du formaldéhyde, peuvent être négligés au niveau des unités flavonoïdes, aucun autre site n'étant libre sur le noyau A pour une attaque du formaldéhyde.

Cette approximation ne peut plus être faite pour un flavonoïde polymère, bien que les tanins de type résorcinol et phloroglucinol soient trop instables et réactifs pour permettre une réaction, avec le formaldéhyde, via une condensation avec un autre noyau A [Pizzi, 1977].

L'équation de la vitesse globale peut être représentée ainsi:

$$\text{Vitesse} = k_{1+2} [\text{aldéhyde}] [\text{tanin-OH}]^a [\text{tanin-O}^-]^{1-a} + [\text{aldéhyde}] [(-\text{CH}_2\text{-tanin-})_n] \quad (5)$$

Où [tanin-OH] est la concentration en tanins et [tanin-O⁻]^{1-a} est la concentration en tannates. A 25°C et pH = 9, les constantes cinétiques de la réaction du formaldéhyde avec les flavonoïdes des tanins de Mimosa prennent les valeurs $k_{1+2} = 4.61 \times 10^{-2} \text{ l.mole}^{-1} \cdot \text{sec}^{-1}$ et $\sum_n k_n = 3.3 \times 10^{-3} \text{ l.mole}^{-1} \cdot \text{sec}^{-1}$ pour un rapport formaldéhyde : sites réactifs (sur les unités flavonoïdes liées) de 1:1 (pour les tanins de Mimosa, la moyenne des sites réactifs sur les unités liées est de 1.25). En milieu acide, la réaction est également du second ordre, la situation devient alors très complexe, une grande variété d'espèces contribuant à la cinétique globale.

Dans le cas du formaldéhyde:

$$\begin{aligned} \text{Vitesse} = & k_1 [\text{HCHO}] [\text{tanin-OH}] + k_2 [\text{CH}_2\text{OH}^+] + \\ & k_3 [\text{HCHO}] [\text{tanin-O H}^+_2] + k_4 [\text{CH}_2\text{OH}^+] [\text{tanin-OH}^+_2] + \\ & k_5 [\text{HCHO}_{\text{libéré}}] + [\text{HCHO}] \sum_{n1} k_{n1} [(-\text{CH}_2\text{-tanin-})_{n1}] + \\ & [\text{CH}_2\text{OH}^+] \sum_{n2} k_{n2} [(-\text{CH}_2\text{-tanin-})_{n2}] \end{aligned}$$

A partir de la figure 12 (pour les pH acides), il est possible d'évaluer la contribution du terme en k_5 . La forme de la courbe met en évidence le fait que le formaldéhyde est libéré plus qu'il n'est consommé. En combinant les termes en k_1 et k_2 et en négligeant les termes en k_3 , k_4 et k_{n2} , qui sont effectivement

négligeables de pH 5 à 6, l'équation (6) à pH moyennement acide peut alors s'exprimer ainsi:

$$\text{Vitesse} = k_1 [\text{HCHO}] [\text{tanin}] + k_5 [\text{HCHO}_{\text{libéré}}] + [\text{CH}_2\text{OH}^+] \sum_{n2} k_{n2} [(-\text{CH}_2\text{-tanin-})_{n2}] \quad (7)$$

Les constantes cinétiques de la réaction du formaldéhyde avec les flavonoïdes des tanins de Mimosa prennent à pH 4.9 et à 25°C les valeurs $k_1 = 6.94 \times 10^{-3} \text{ l.mole}^{-1}.\text{sec}^{-1}$ et $\sum_n k_n = 4.3 \times 10^{-4} \text{ l.mole}^{-1}.\text{sec}^{-1}$ et $k_5 = -1.9 \times 10^{-4} \text{ l.mole}^{-1}.\text{sec}^{-1}$ pour un rapport formaldéhyde : sites réactifs (sur les unités flavonoïdes liées) de 1:1.

Nous pouvons voir sur la figure 12 que la concentration en aldéhyde, en fonction du temps, montre clairement que deux réactions compétitives coexistent: la réaction de l'aldéhyde avec le tanin et celle avec les produits de faible poids moléculaire de la réaction aldéhyde-tanin; cette réaction est à l'origine de la consommation d'aldéhyde.

L'aldéhyde qui s'est libéré est à nouveau prêt à réagir. Cette réaction est probablement due à la transformation des ponts de type méthylène éther instables initialement formés $-\text{CH}_2\text{-O-CH}_2-$ en ponts de type méthylène $-\text{CH}_2-$.

Il est intéressant de noter que même si les ponts de type méthylène éther $-\text{CH}_2\text{-O-CH}_2-$ ont déjà été isolés lors de la réaction phénol/formaldéhyde [Kulvik, 1977], leur existence lors de la réaction de produits phénoliques plus réactifs, comme le résorcinol ou le phloroglucinol, a été supposée mais n'a jamais pu être mise en évidence. Une analyse des produits des réactions résorcinol/formaldéhyde et phloroglucinol/formaldéhyde n'a montré aucune différence entre les produits obtenus en milieu acide et ceux obtenus en milieu alcalin [Roux et al, 1975; Scharfetter et al, 1977].

La figure 12 nous donne peut être les premières indications quant à l'existence de ces ponts de type méthylène éther lors de la réaction du résorcinol, du phloroglucinol et des noyaux A des flavonoïdes. La vitesse à laquelle ils se forment, puis disparaissent, explique bien évidemment la difficulté à les isoler alors que les produits de la réaction sont identiques, que le milieu soit acide ou alcalin. Il apparaît par ailleurs que les éthers formés lors de la réaction phénol-formaldéhyde se décomposent rapidement à des températures supérieures à 130°C, alors que la réactivité du résorcinol, du phloroglucinol et des noyaux A

des flavonoïdes vis-à-vis du formaldéhyde, et par conséquent la formation et la décomposition de ponts de type méthylène éther, est maximale à des températures bien plus faibles (25°C). Ceci est tout naturellement dû à la tendance toujours présente qui pousse le pont de type méthylène éther à se recombinaison en pont de type méthylène, avec libération de formaldéhyde.

L'augmentation de la masse moléculaire de l'aldéhyde, et donc de son encombrement stérique, provoque une diminution du nombre d'éthers formés ainsi que de leur vitesse de formation [Rossouw, 1979]. Ceci est bien visible sur la figure 12 où la pente correspondant à la libération d'aldéhyde diminue du formaldéhyde (pente la plus raide) à des aldéhydes plus encombrés stériquement. La stabilité de l'éther formé augmente avec l'encombrement stérique de ce dernier, ainsi dans le cas du furaldéhyde, l'éther formé devrait être le plus stable. Il est impossible d'exclure le fait que le formaldéhyde libéré pendant la réaction puisse avoir d'autres origines que la modification du pont de type méthylène éther en pont de type méthylène.

Dans la pratique, en fait seuls deux aldéhydes, le formaldéhyde et le furaldéhyde, sont utilisés dans la préparation d'adhésifs à base de tanins. D'autres aldéhydes sont, bien entendu, parfois utilisés, mais combinés avec le formaldéhyde, lorsque certaines propriétés physiques sont recherchées. Ainsi, 10 à 30% du formaldéhyde peuvent être remplacés par du n-butyraldéhyde, qui est hydrophobe grâce à sa chaîne carbonée insaturée, ce qui augmente la résistance des adhésifs tanin-formaldéhyde vis-à-vis de l'eau en modifiant la structure du réseau formé tout en évitant l'utilisation d'agents tels que des cires cosmétiques [Rossouw, 1979]. Les adhésifs à base de tanins préparés avec d'autres aldéhydes que le formaldéhyde (ou préparés avec du formaldéhyde et une forte proportion d'autres aldéhydes) donnent un réseau plus fort que celui obtenu avec le formaldéhyde seul ou mélangé au furaldéhyde [Pizzi, 1977].

Les valeurs de k_1 pour un rapport flavonoïdes de Mimosa : formaldéhyde de 1:1 à un pH de 9 sont supérieures à celles obtenues à un pH de 4.9, ce qui indique que la réaction est plus rapide à pH élevé. En conséquence, il est possible de corrélérer la vitesse de réaction, ou plutôt les constantes cinétiques, et le temps de gel. L'influence des différents termes composant l'équation de la vitesse de réaction peut facilement être déduite de l'allure de la figure 13 schématisant le temps de gel, proportionnel à la vitesse globale de la réaction, en fonction du pH. Une courbe représente la réactivité vis à vis des phénols des différentes espèces

chimiques formées à partir du formaldéhyde (figure 14). L'autre courbe représente la réactivité des différentes espèces phénoliques vis à vis du formaldéhyde. La troisième courbe est la résultante des deux premières et peut être comparée à la courbe des temps de gel expérimentaux (figure 13). La figure 14 est uniquement qualitative.

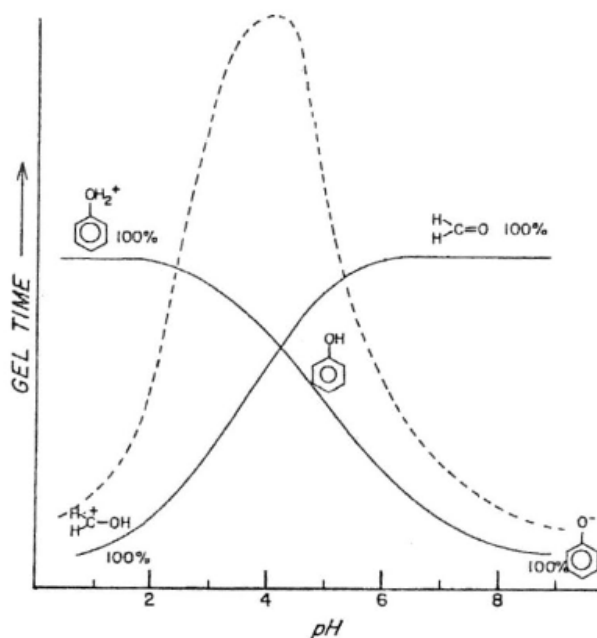

Figure 14 : Représentation qualitative de la réactivité de phénols vis à vis du formaldéhyde et des espèces générées à partir du formaldéhyde vis à vis des phénols [Plomley, 1966].

Pour conclure, la vitesse de réaction dépend également de la concentration en catalyseur, généralement NaOH, et ainsi du pH. Pour cette raison, les coefficients k se doivent d'être donnés à des pH définis. Dans le cas de réactions où un effet de catalyse acide/base intervient, comme dans la réaction entre les flavonoïdes et le formaldéhyde, une constante cinétique peut être ainsi définie:

$$k = k_0 + k_{H^+} [H^+] + k_{OH^-} [OH^-] \quad (8)$$

Réactivité avec le glyoxal

Des études récentes ont montré que les tanins pouvaient réagir avec le glyoxal de préférence quand le pH est élevé.

Le tanin de pin a été utilisé pour évaluer le temps de gel en présence de glyoxal et le comparer à celui obtenu avec le formaldéhyde [Ballerini et al, 2005].

Ces résultats encourageants, reportés en Figure 15, ont permis la fabrication de panneaux de particules présentant des propriétés satisfaisantes du point de vue collage. L'utilisation de ce durcisseur peut, en tout cas, être envisagée dans des applications pour lesquelles le formaldéhyde est interdit et permet d'obtenir un produit innovant.

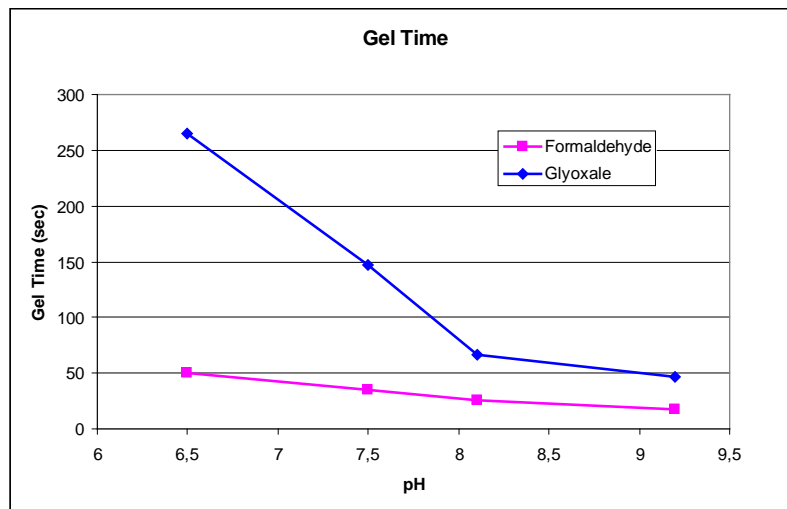

Figure 15: Comportement du glyoxal par rapport à celui du formaldéhyde à différents pH dans le processus de durcissement du tanin de Pin.

Autocondensation acide

A chaud, et en présence d'acides minéraux forts, les tanins sont susceptibles de réagir de deux manières différentes. Une des réactions dégrade les polymères et mène à la formation de catéchine et d'anthocyanidines comme l'illustre le biflavanoïde typique (figure 16). La deuxième réaction est une condensation résultant de l'hydrolyse des hétérocycles (liaisons p-hydroxybenzyléther) [Roux *et al*, 1975]. Les ions p-hydroxybenzylcarbonium (figure 17) créés se condensent alors avec les sites nucléophiles d'autres unités de tanin pour former les *phlobaphènes* ou *tanins rouges*.

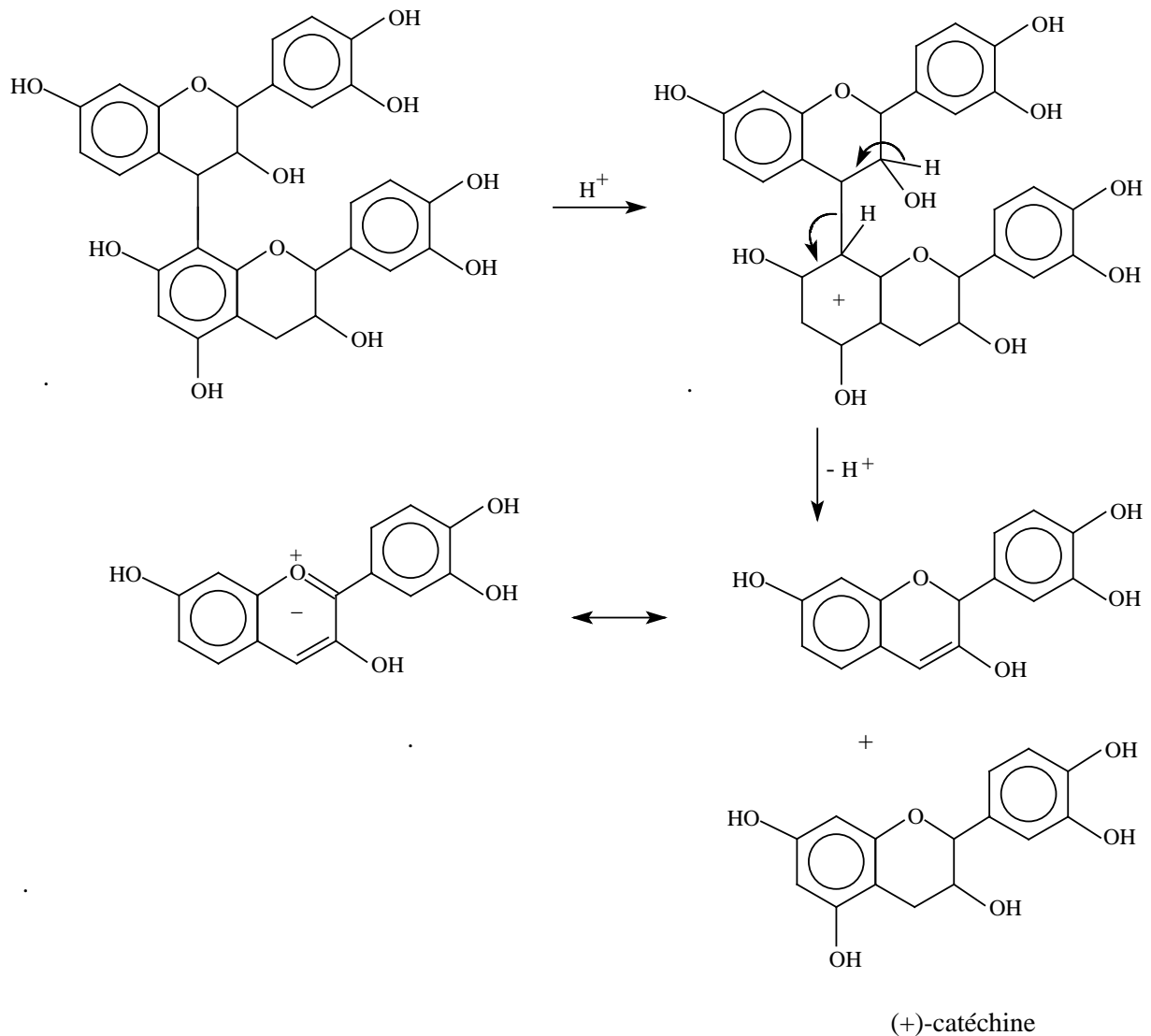

Figure 16: Dégradation des tanins à catéchine et anthocyanidine.

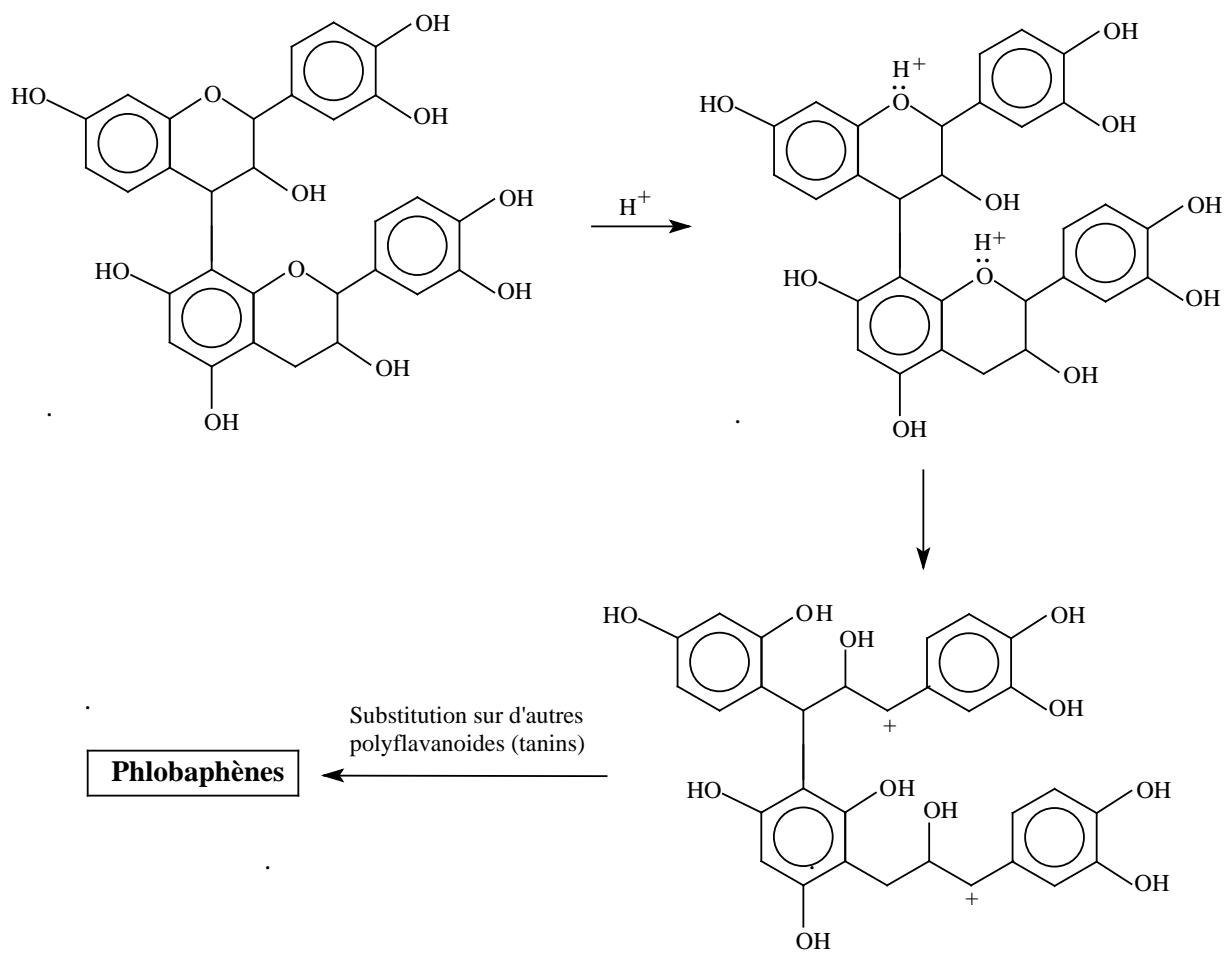

Figure 17: Autocondensation acide par hydrolyse des hétérocycles.

Autocondensation alcaline

En milieu alcalin, les tanins sont également susceptibles de réagir de deux manières différentes. La première réaction (figure 18) est la rupture de la liaison interflavanoïde 4-8. Cette réaction intervient dans les tanins de Pin et de noix de Pécan, mais pas (ou très peu) dans le tanin de Mimosa [Pizzi et Stephanou, 1993]. Le carbocation formé peut mener à une autocondensation (figure 18).

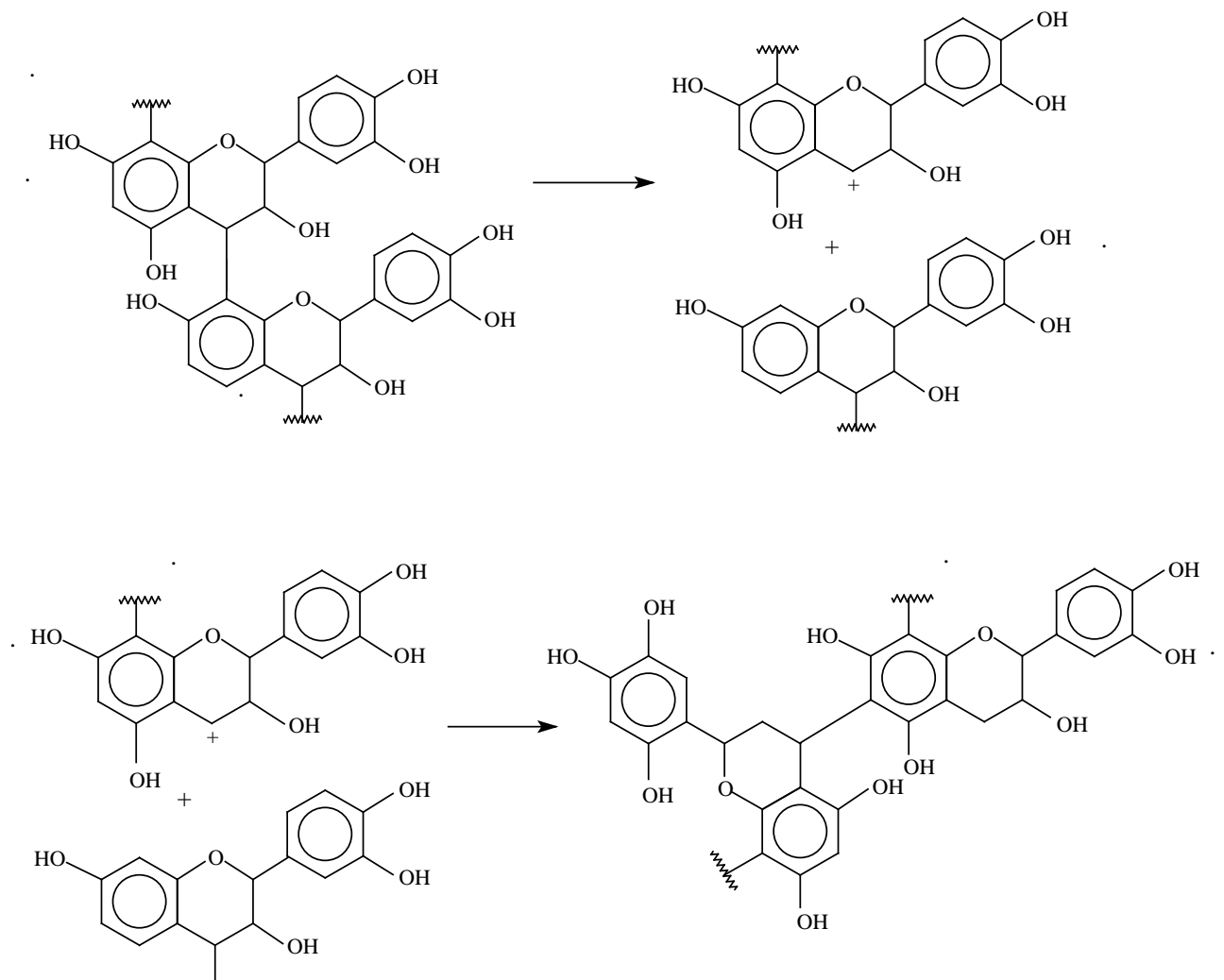

Figure 18 : Autocondensation alcaline: rupture de la liaison interflavanoïde et autocondensation finale.

La seconde réaction est une autocondensation partielle due à l'augmentation de réactivité provoquée par l'ouverture de l'hétérocycle. Récemment, il a été montré que les tanins de noix de Pécan, majoritairement prodelphinidique, s'autocondensent rapidement, sans pour autant former un réseau tridimensionnel comme une résine durcie [*Pizzi et Stephanou, 1993*]. Ceci est clairement visible lorsqu'en milieu alcalin la catéchine, monomère, en solution s'autocondense lors du réarrangement catéchinique bien connu [*Ohara et Hemingway, 1991*], comme indiqué sur la figure 19.

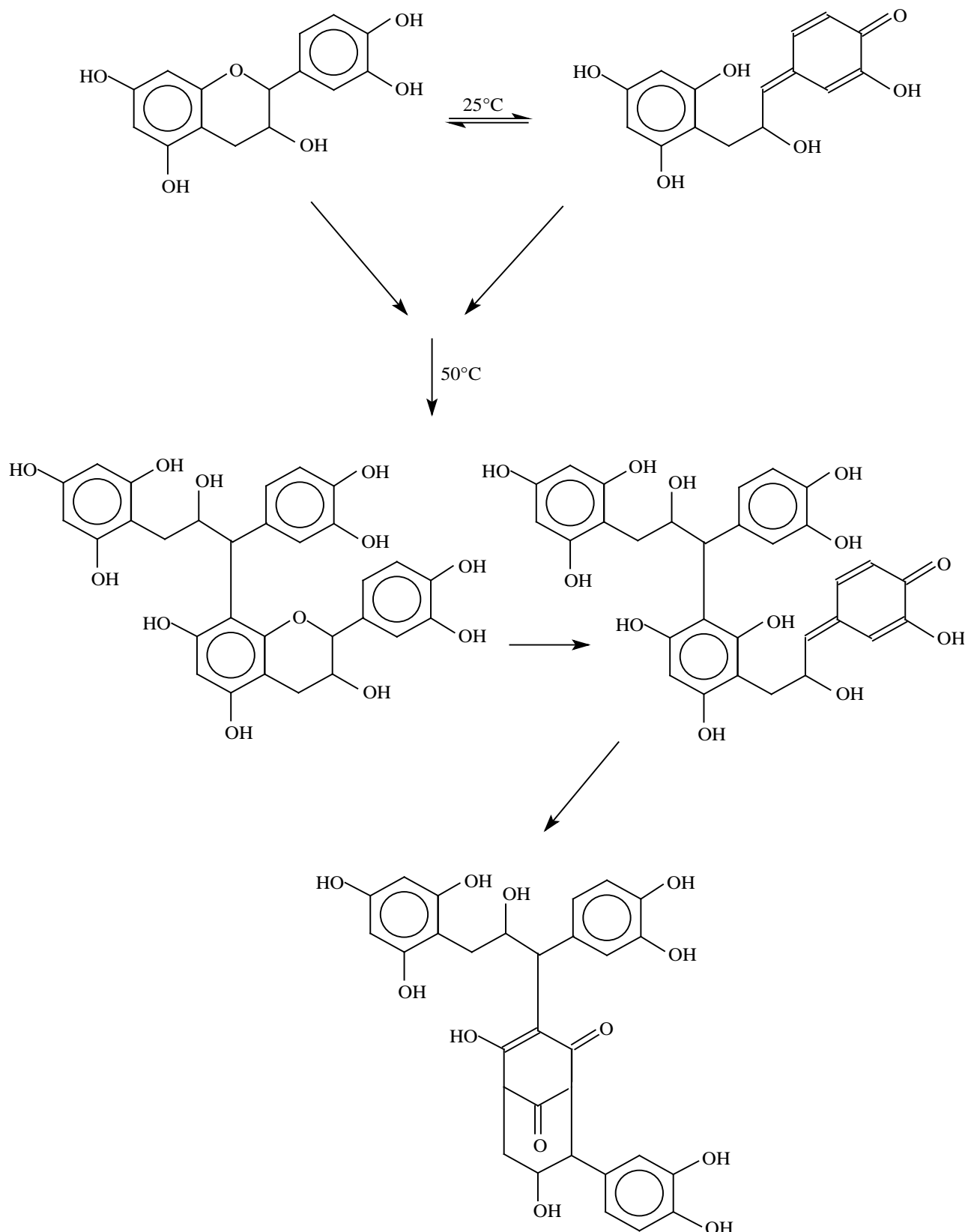

Figure 19: Réarrangement catéchinique.

Autocondensation alcaline catalysée par la silice.

En milieu alcalin, les tanins condensés sont donc susceptibles de s'autocondenser pour donner des polymères thermodurcissables. Cette réaction est catalysée par la silice SiO_2 selon le mécanisme supposé suivant [Meikleham, Pizzi et Stephanou, 1994] :

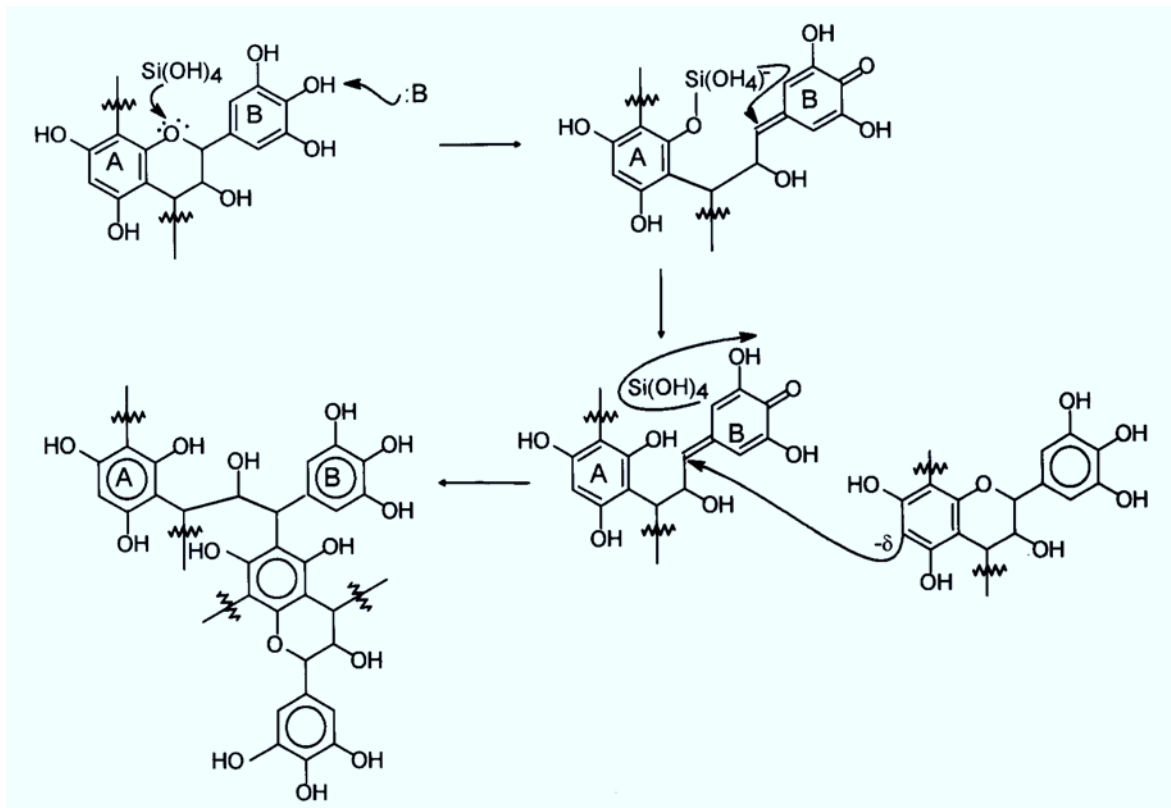

Figure 20: Mécanisme de réaction d'autocondensation proposé pour expliquer le durcissement des tanins condensés à pH basique en présence de petites quantités de SiO_2 .

Des cinétiques comparatives de l'autocondensation radicalaire induite par SiO_2 d'un tanin polyflavonoïde ont été effectuées par résonance paramagnétique électronique (RPE). Le tanin de quebracho qui est principalement profisetinidine /prorobinétinidine a été étudié à l'état naturel, sulfité, de glucide libre et dans sa forme intermédiaire adhésif. Les résultats obtenus ont non seulement confirmé l'existence de mécanismes radicalaires forts d'autocondensation en présence de SiO_2 dissoute, mais ont également souligné de nouveaux effets d'intérêt dans une telle réaction. La réaction d'autocondensation procède plus rapidement et la

solution de tanins devient plus colloïdale. L'état colloïdal de la solution semble dépendre principalement, mais pas exclusivement, de la présence de polymères glucidiques dans l'extrait [Masson, Merlin et Pizzi, 1996].

Les intensités relatives des signaux en RPE d'anions radicaux et de radicaux phénoxyles, indiquent que l'ouverture des cycles pyraniques des tanins et l'autocondensation sont rapides dans des conditions alcalines [Merlin et Pizzi – 1996].

La présence ou l'absence d'interférences sur la réaction d'autocondensation radicalaire des tanins polyflavonoïdiques par des mécanismes de durcissement ionique via des co-réactifs ioniques ont été étudiées par RPE. Dans certains cas, le durcissement par co-réactifs ioniques peut être couplé avec le durcissement simultané du tanin par autocondensation radicalaire [Garcia, Pizzi et Merlin – 1997].

La réaction a lieu en deux étapes: la première, la formation de radicaux-anions, la deuxième, la condensation à proprement parler avec les autres unités flavonoïdes des sites réactifs formés. L'étape cinétique déterminante dépend à la fois de la structure principale de l'unité flavonoïde de chaque tanin et en particulier du niveau de l'état colloïdal de la solution de tanin et du degré moyen de polymérisation en nombre (Dpn). Il a été montré que les tanins hydrolysables ne subissent ni réaction de formation de radicaux catalysée par la silice, ni autocondensation comme on pourrait s'y attendre à partir de leurs structures [Masson, Pizzi et Merlin – 1997].

L'Alcool Furfurylique



Caractéristiques Physico-chimiques

L'alcool furfurylique est un produit liquide à température ambiante, transparent et incolore ou jaune clair selon l'état de conservation du produit. Ce produit d'origine naturelle est classé comme irritant pour le système respiratoire, nocif en cas d'ingestion et par contact avec la peau, toxique par inhalation, soupçonné de provoquer le cancer. Malgré ces inconvénients notoires, il est très intéressant car il présente une très bonne réactivité.

Ce composé organique présente des caractéristiques aromatiques et alcooliques:

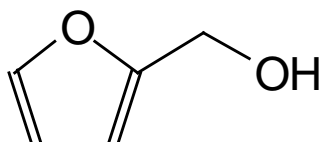

Les caractéristiques physico-chimiques les plus importantes de l'alcool furfurylique sont sa forte solubilité dans l'eau et dans les alcools de bas poids moléculaire et sa haute sensibilité chimique aux oxydations et aux polymérisations. Ce produit est utilisé principalement dans la chimie des résines, des peintures, des matériaux synthétiques et surtout dans l'industrie des fonderies.

Production de l'Alcool Furfurylique

L'alcool furfurylique est un composé fondamental pour la chimie des mousses de tanin parce qu'il représente environ 20% du poids des mousses une fois qu'elles sont produites.

Ce composé chimique est généralement obtenu à partir des hémicelluloses de différents types de produits agricoles comme le blé ou le maïs ou de déchets comme la sciure, et il est de ce fait considéré comme un produit naturel (Figure 21).



Figure 21: Exemples de produits naturels pour la production du furfural: maïs, avoine et blé.

L'alcool furfurylique est obtenu via deux réactions principales qui sont:

1) L'hydrolyse des pentosanes des hémicelluloses en furfural.

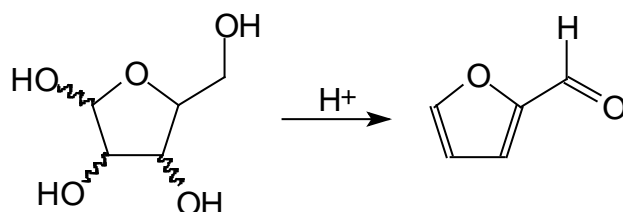

Plusieurs procédés et substrats sont décrits dans la littérature pour la production du furfural [Sproull et al, 1986; Pessoa et al, 1997].

2) L'hydrogénation catalytique à haute pression du furfural.

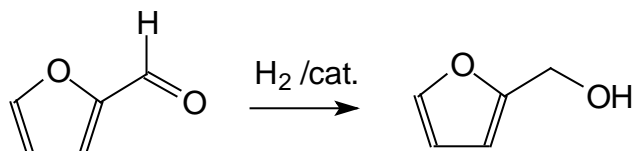

Les catalyseurs sont constitués généralement par des métaux. Des études récentes ont montré l'efficacité des mélanges Co-Mo et B [Chen et al., 2002] et Cu-MgO [Nagaraja et al., 2002].

Réactivité de l'alcool Furfurylique.

L'alcool furfurylique peut être transformé en 2,5-bis(hydroxyméthyl)furane par formylation [Gandini et Belgacem, 1997]:

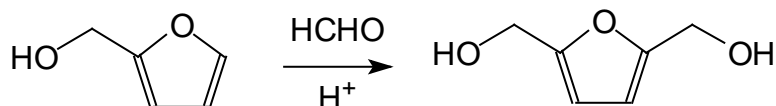

Cette réaction avec le formaldéhyde permet d'activer ultérieurement l'alcool furfurylique et peut être un intermédiaire très commun dans la polymérisation mixte avec les tanins condensés.

L'alcool furfurylique est par ailleurs connu pour subir une homocondensation très exothermique en milieu acide selon le mécanisme suivant

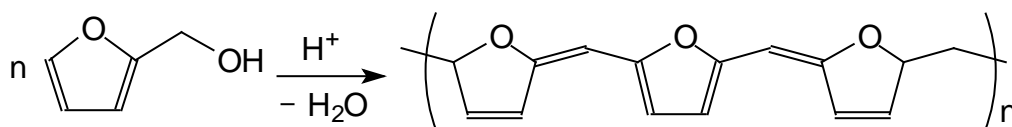

Une fois que l'énergie d'activation de cette réaction est atteinte, le processus s'auto alimente et tout l'alcool furfurylique se transforme rapidement en polyalcool furfurylique.

Pour comprendre le mécanisme de polymérisation de l'alcool furfurylique, des analyses par spectroscopies UV, FTIR et RMN ont été réalisées sur des polymères furaniques en phase solvant et sous atmosphère d'azote [Choura et al, 1996].

La réaction de polycondensation peut conduire à des polymères ramifiés et la présence de structures tridimensionnelles n'est pas rare.

Beaucoup d'études ont été menées sur ces polymères car ils possèdent entre autres propriétés une très grande résistance à la chaleur et à la corrosion et une faible inflammabilité. C'est pourquoi ce produit est utilisé dans l'industrie des fonderies et la formulation de vernis anti-corrosifs.

Réactivité de l'alcool furfurylique avec les tanins

Des études de base ont été conduites sur la réactivité de l'alcool furfurylique avec les tanins [Foo and Hemingway, 1985].

Pour ces recherches, la catéchine a été choisie pour réagir sur l'alcool furfurylique en milieu acide en prenant en compte la réactivité élevée de l'alcool sur lui-même quand le pH est très bas. Aussi, la réaction a été réalisée dans une solution d'acide acétique à une température de 100°C. Deux produits distincts ont été obtenus par cette réaction après séparation et purification par HPLC en phase inverse : un flavonoïde substitué par un groupement furanyle en position 8 (figure 22A) et un autre en position 6 (figure 22B) avec un rendement de 4% et 1,5% respectivement.

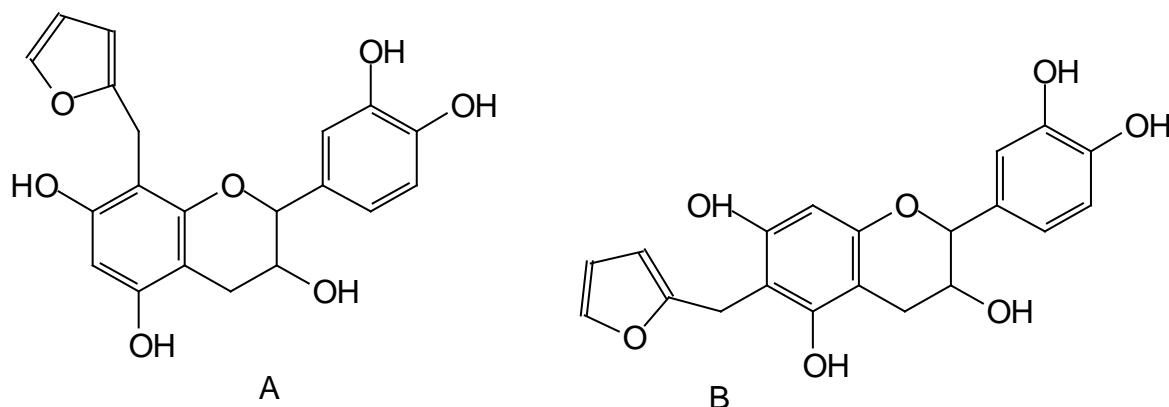

Figure 22: Produits obtenus après réaction de l'alcool furfurylique sur la catéchine: A- 4% et B- 1,5% rendement.

La plus grande réactivité de la position 8- par rapport à la position 6- a déjà été montrée surtout pour des substituants de fort encombrement stérique.

D'autres études ont été menées sur la réactivité de l'alcool furfurylique avec le tanin de mimosa.

La Figure 23 montre les différents temps de gel en fonction du type de durcisseur utilisé et du pH.

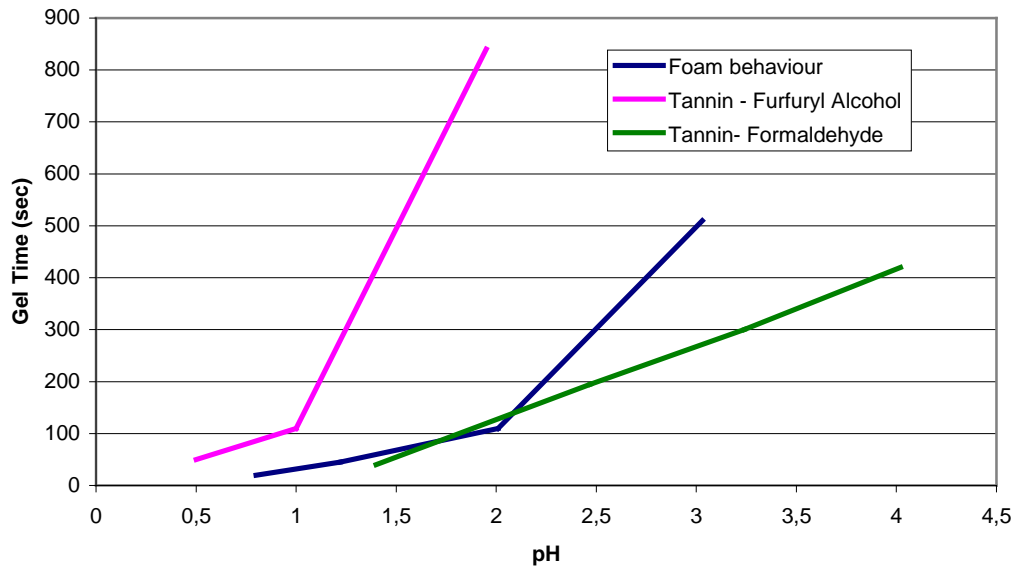

Figure 23: Evolution du temps de gel selon le pH pour un mélange tanin-formaldehyde (vert); un mélange tanin-alcool furfurylique (rose); un mélange tanin-formaldehyde-alcool furfurylique (bleu).

Ces résultats montrent que le formaldéhyde joue un rôle de la première importance dans la formation du réseau polymère pour la production de mousses de tanin.

Les Mousses

Les mousses sont des matériaux complexes qui résultent de la dispersion d'un gaz dans un milieu condensé. Selon le type de milieu condensé, les mousses peuvent être liquides ou solides.

La formation des mousses est un processus qui se passe régulièrement dans la nature quand des gaz sont mélangés par action mécanique dans un liquide.

Un exemple banal est la formation de l'écume des vagues dans laquelle de l'air reste piégé pour quelques secondes dans l'eau.

Les mousses liquides sont des matériaux qui font partie de notre quotidien: les mousses de tensioactifs, la mousse à raser, la mousse du lait, du cappuccino ou de la bière en sont des exemples parlants.

Les mousses solides sont plus difficiles à trouver dans la nature. De manière générale, elles sont produites par le dégagement d'un gaz dans un milieu liquide très visqueux qui durcit pendant que le gaz se libère. Toutes les mousses solides sont produites ainsi.

Il existe beaucoup d'exemples de ces mousses dans la vie quotidienne : le pain, la majorité des gâteaux, la mousse au chocolat... Mais les mousses solides peuvent être aussi produites par le durcissement d'un polymère. Les matelas en latex, les canapés et les sofas en mousse polyuréthane, les mousses EVA ou PU pour les semelles des chaussures de sport sont des exemples qui montrent combien la technologie des mousses est adaptée à la vie de l'homme.

Au XIX siècle, le mathématicien belge Joseph Plateau s'est intéressé à ce type de matériaux et a fait de nombreuses études sur les mousses liquides. C'est grâce à lui que les principes fondamentaux ont été compris.

Quatre points fondamentaux ont été déduits par Plateau:

1. Les surfaces des mousses sont complètement lisses;
2. la courbure moyenne de chaque portion de paroi est constante;
3. les films de mousse se rencontrent toujours à trois et forment un angle de 120° ;
4. Dans l'espace, quatre parois de mousse se coupent toujours sous un angle de $109^\circ 47'$.

Les mousses qui n'ont pas cette structure ne sont pas stables et se réorganisent rapidement.

Des études sur la distribution et la forme des différentes cellules dans une structure de mousse statique ont été menées dans les années 90 [Weaire et Phelan, 1996]. Elles ont permis de comprendre que pour un volume donné, les cellules adoptent deux types de géométries polyédriques pour réduire leur surface (Cf. Figure 24).

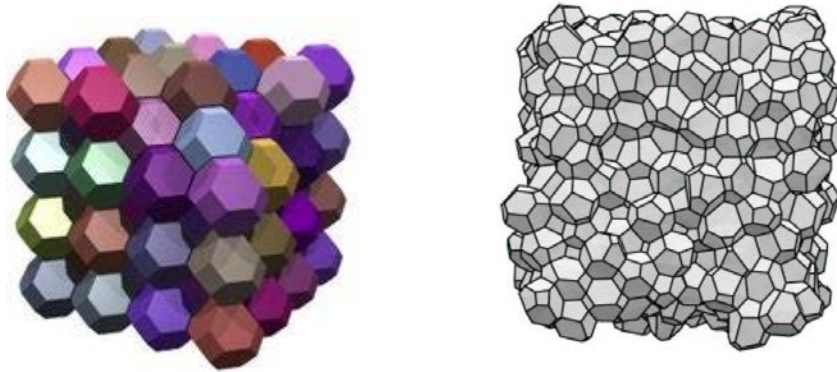

Figure 24: Disposition schématique d'une mousse: Idéale (constituée uniquement de tétrakaidécaèdres) Réelle (comportant 25% de dodécaèdres).

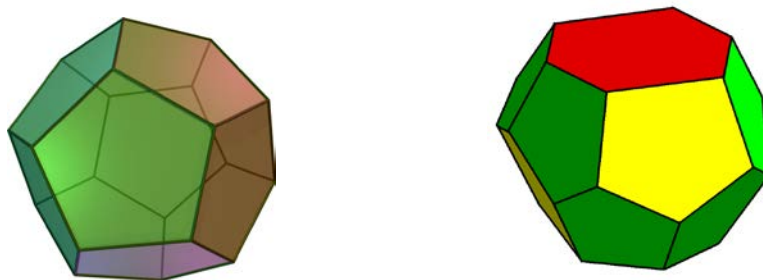

Figure 25: Structure tridimensionnelle d'une cellule de mousse: dodécaèdre et tétrakaidécaèdre.

Le volume d'une mousse est donc constitué par 75% de tétrakaidécaèdres (polyèdres formés par 12 pentagones et 2 hexagones) et par 25% de dodécaèdres (formés de 12 pentagones)

Les mousses solides

Les mousses solides sont une classe de matériaux caractérisés généralement par une grande légèreté et une structure à cellules qui leur garantissent des applications intéressantes en ingénierie.

Ils peuvent être classifiés selon le type de cellules. Les mousses à cellules ouvertes ont des pores qui connectent les cellules. Les structures de ce type sont relativement plus légères.

Les mousses à cellules fermées ont une structure beaucoup plus rigide car les parois ne sont pas trouées et peuvent supporter des efforts de compression plus importants. Généralement, ces mousses sont plus denses et donc sont plus coûteuses si on considère le prix par m³.

Les mousses solides peuvent aussi être classées selon leurs propriétés physiques:

- Les mousses élastiques ont la propriété d'être déformables tout en reprenant leur forme originale lorsque la contrainte qu'on leur applique disparaît. Le marché de ces mousses est dominé par les mousses polyuréthanes mais les latex et les mousses EVA sont aussi très utilisées dans des secteurs spécifiques comme les matelas et les accessoires de sport.



Figure 26: Applications commerciales pour des mousses élastiques.

- Les mousses rigides au contraire sont des matériaux qui ne se déforment pas et qui trouvent comme principales applications, l'isolation thermique et acoustique des bâtiments.

Les mousses rigides les plus vendues sont les polyuréthanes et les phénoliques.

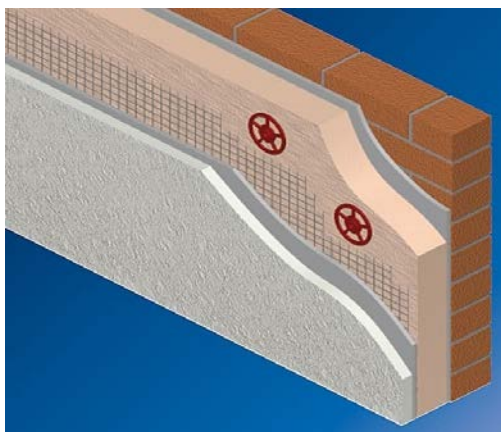

Figure 27: Applications commerciales pour des mousses rigides.

Les mousses naturelles

Les mousses synthétiques sont des matériaux assez courants. En revanche, les mousses naturelles sont plutôt rares.

Face aux polyuréthanes majoritaires sur le marché des mousses élastiques, les alternatives naturelles telles que les latex sont en train de se développer. Pour ce qui est des mousses rigides, en revanche, très peu de produits naturels sont envisageables.

De nombreuses études ont été réalisées pour utiliser des produits naturels pour l'isolation des habitations [Dweib et al, 2004] mais jamais sous forme de mousses rigides.

Aussi l'application de mousses rigides de tanins représente une innovation technologique indéniable dans ce secteur.

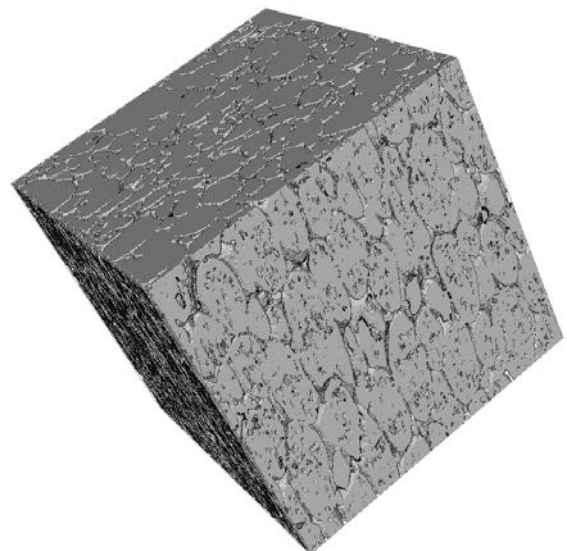

Figure 28 : Mousse rigide à base de tanin et image complémentaire agrandie

Résultats et discussions

Dans ce travail de thèse, la composition chimique de tanins synthétiques et végétaux a été étudiée. Puis ces différents types des tanins ont été utilisés pour faire des matériaux expansés, tant rigides qu'élastiques, à cellules ouvertes ou fermées, en présence ou en absence de solvants organiques et de catalyseurs acide ou alcalin.

A partir du travail réalisé, des demandes de brevets italiens et internationaux PCT ont été déposées et sont actuellement évaluées par le bureau européen des brevets (EPO) selon la procédure standard internationale.

Des matériaux nouveaux qui présentent de nombreux avantages tant du point de vue écologique, technique et économique ont été synthétisés. Il s'agit de mousses à base principalement de tanins et d'alcool furfurylique. Ces matériaux suscitent un vif intérêt dans le monde scientifique d'où une publication très large de la majorité de nos recherches sur ce sujet. Les résultats obtenus pendant le développement du projet ont été parfois légèrement modifiés ou affinés au fur et à mesure que des informations complémentaires plus détaillées ont été trouvées. Les 12 publications, dont 2 brevets, présentées dans ce travail de thèse contiennent des informations qui permettent d'évaluer dans le détail les caractéristiques des différentes mousses organiques préparées et de leurs applications industrielles et commerciales potentielles.

Un large panel de techniques analytiques a été utilisé pour identifier les propriétés de ces nouveaux matériaux qui par leurs propriétés exceptionnelles commencent à être prises en considération par la communauté scientifique et les entreprises.

Afin de mieux présenter les travaux de cette thèse, les publications et les demandes de brevet sont groupées en trois chapitres :

- *Caractérisation des tanins*

- *Nouvelles résines de tanins écosoutenables*

- *Mousses de tanins écosoutenables.*

Les articles ont été soumis dans des journaux différents mais dont les thèmes sont complémentaires afin d'introduire les mousses de tanins et présenter leurs potentialités à un public le plus large possible. Sur les deux demandes de brevet déposées, une a déjà été étendue au niveau international. Ces travaux ont suscité beaucoup de discussions, de réunions et de contrats de collaboration entre l'Université de Lorraine et Silvateam, entreprise italienne qui produit des tanins, et d'autres entreprises au niveau international.

Caractérisation des tanins.

Structure moléculaire des tanins synthétiques par la spectrométrie de masse MALDI-TOF.

Auteurs: S.GIOVANDO, A.PIZZI, H.PASCH, K.RODE

J.Appl.Polymer Sci., 114: 1339 - 1347 (2009)

Dans cette étude, nous avons déterminé la composition, au niveau moléculaire, des tanins synthétiques ou syntans par la technique MALDI-TOF déjà utilisée pour les tanins végétaux et beaucoup d'autres polymères.

Nous avons évalué ces substances qui sont principalement des polymères dérivés de la condensation du phénol, du naphthalène et de la 4,4'- dioxydiphénylsulfone avec du formaldéhyde et/ou de l'urée.

La distribution des oligomères a indiqué que l'abondance relative des oligomères, à partir des trimères jusqu'à des degrés de polymérisation plus élevés, varie de 70% à plus de 90% selon les différents tanins synthétiques testés.

Cette étude a permis d'estimer la quantité de chaque structure moléculaire et vérifier si les tanins synthétiques analysés sont des polymères qui répondent aux spécifications de la réglementation européenne REACH.

S.GIOVANDO, A.PIZZI, H.PASCH, K.RODE, Synthetic tanins structure by MALDI-TOF mass spectrometry, ***J.Appl.Polymer Sci.***, 114: 1339 - 1347 (2009)

Synthetic Tannins Structure by MALDI-TOF Mass Spectroscopy

S. Giovando,¹ A. Pizzi,² H. Pasch,^{3,4} K. Rode⁴

¹*Centro Ricerche per la Chimica Fine Srl, S.Michele Mondovi', Italy*

²*ENSTIB-LERMAB, Nancy University, Epinal, France*

³*Polymer Research Institute, University of Stellenbosch, Stellenbosch, South Africa*

⁴*Analytical Department, Deutsche Kunststoff Institut, Darmstadt, Germany*

Received 11 February 2009; accepted 27 April 2009

DOI 10.1002/app.30667

Published online 18 June 2009 in Wiley InterScience (www.interscience.wiley.com).

ABSTRACT: The structure, polymeric nature, and oligomers distribution of six types of commercial synthetic tannins (syntans) were determined by MALDI-TOF mass spectrometry. The syntans examined were: (i) polycondensation oligomers of sulfonated phenol and 4,4'-dioxydiphenylsulfone with formaldehyde and sodium bisulfite; (ii) sodium salts of polycondensation oligomers of phenol and sulfonated phenol with formaldehyde and urea; (iii) sodium salts of polycondensation oligomers of sulfonated phenol with formaldehyde and urea; (iv) sodium and ammonium

salts of polycondensation oligomers of sulfonated naphthalene with formaldehyde; and (v) a sulfonated phenolic novolak resin. The oligomers distribution indicated that the relative abundance of oligomers from trimer to higher degrees of polymerization varied from 70% to more than 90% according to the different syntans tested. © 2009 Wiley Periodicals, Inc. *J Appl Polym Sci* 114: 1339–1347, 2009

Key words: syntans; MALDI; resins; tannins; polycondensation; structure

INTRODUCTION

Vegetable tannins have been used to tan leather either alone or accompanying other tanning agents for several thousand years. Forestry derived vegetable tannins have however a considerable disadvantage, namely, they present marked darkening problems when exposed to light and even worse they give leather that does shrink already at relatively lower temperatures than chrome tanning.^{1,2} Conversely, synthetic tanning agents (syntans) give either lighter colored leathers and high resistance to degradation induced by light.

Synthetic tanning agents (syntans), namely, sulfonated phenol-formaldehyde resins, sulfonated melamine-formaldehyde resin,^{1,2} and sulfonated naphthalene-formaldehyde resins are today prepared and used industrially in great amounts for tanning hides into leather presenting special properties or having a particularly light color or improved light stability.^{1,2} Although their general structure is known from the materials and the preparation procedures used, their exact oligomeric structures and in particular their structure distribution have not been investigated before. This article deals with the investigation of commercial syntans oligomer struc-

tures and structure distribution by MALDI-TOF mass spectrometry.

Since its introduction by Karas and Hillenkamp in 1987,³ matrix-assisted laser desorption/ionization (MALDI) mass spectrometry has greatly expanded the use of mass spectrometry toward large molecules and has revealed itself to be a powerful method for the characterization of both synthetic and natural polymers.^{4–16} Fragmentation of analyte molecules on laser irradiation can be substantially reduced by embedding them in a light absorbing matrix. As a result, intact analyte molecules are desorbed and ionized along with the matrix and can be analyzed in a mass spectrometer. This soft ionization technique is mostly combined with time-of-flight (TOF) mass analyzers. This is so as TOF-MS present the advantage of being capable to provide a complete mass spectrum per event, for its virtually unlimited mass range, for the small amount of analyte necessary and the relatively low cost of the equipment.

EXPERIMENTAL

Tannin types

Six types of commercial synthetic tannins (syntans) were used for MALDI-TOF analysis, all supplied from Silva Chimica, S.Michele Mondovi', Italy, namely (i) Blancotan BC, polycondensation oligomers of sulfonated phenol and 4,4'-dioxydiphenylsulfone with formaldehyde and sodiumbisulfite; (ii) sodium Blancotan HLF, sodium salts of polycondensation

Correspondence to: A. Pizzi (antonio.pizzi@enstib.uhp-nancy.fr).

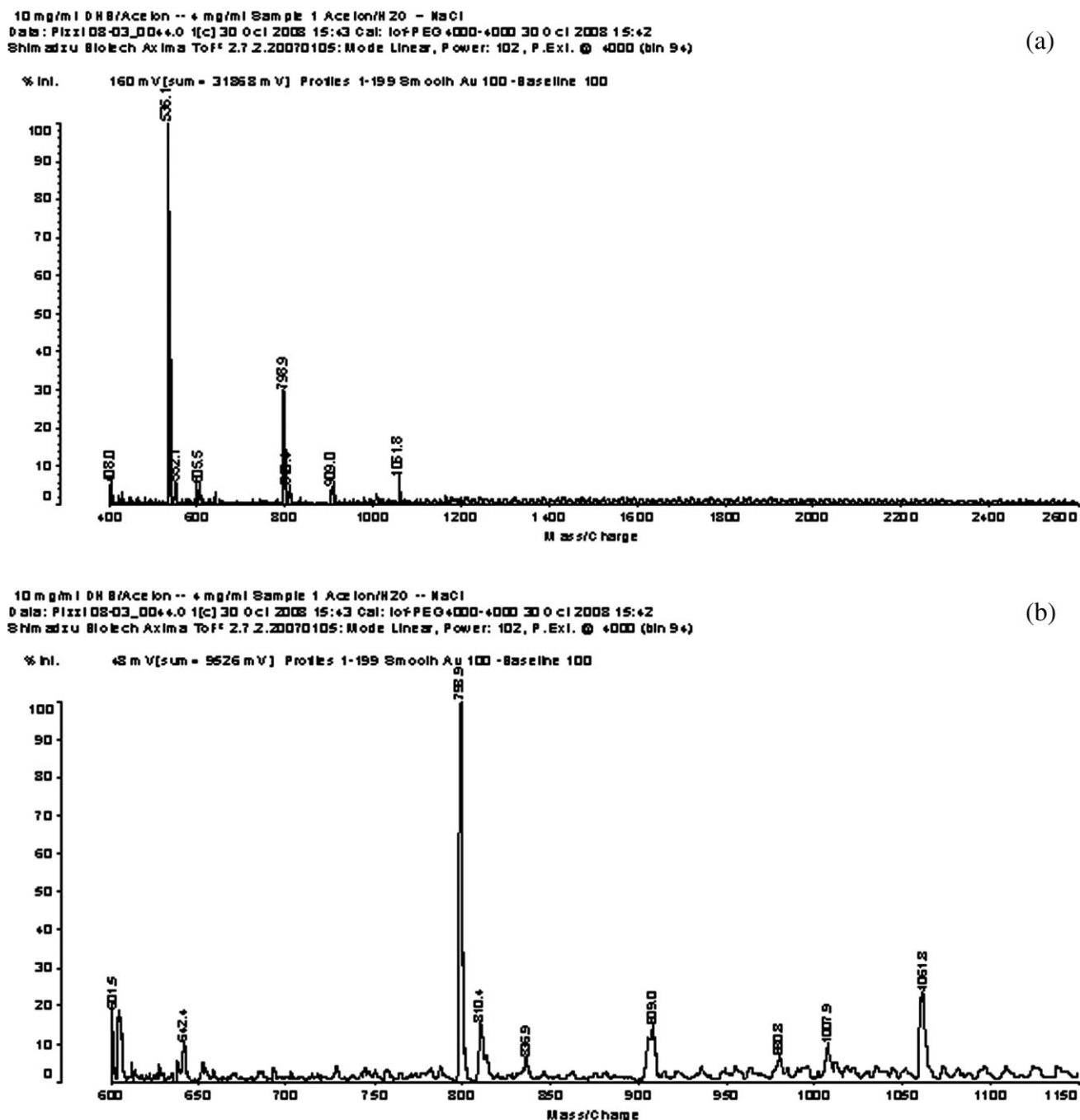

Figure 1 Positive ion mode MALDI-TOF mass spectrum of polycondensation oligomers of the reaction of sulfonated phenol and 4,4'-dioxydiphenylsulfone with formaldehyde and sodium bisulfite. (a) 400–2600 Da. (b) Details of the 600–1150 Da.

oligomers of sulfonated phenol and phenol with formaldehyde and urea; (iii) sodium Blancotan HLF/PC, sodium salts of polycondensation oligomers of sulfonated phenol with formaldehyde and urea; (iv) sodium Blancotan SN, sodium salts of polycondensation oligomers of sulfonated naphthalene with formaldehyde; (v) ammonium Blancotan SN, ammonium salts of polycondensation oligomers of sulfonated naphthalene with formaldehyde; and (vi) Blancotan PRV, sulfonated phenolic novolak resin.

MALDI-TOF-MS

The spectra were recorded on a KRATOS Kompact MALDI AXIMA TOF 2 instrument. The irradiation source was a pulsed nitrogen laser with a wavelength of 337 nm. The length of one laser pulse was 3 ns. The measurements were carried out using the following conditions: polarity-positive, flight path-linear, mass-high (20 kV acceleration voltage), 100–150 pulses per spectrum. The delayed extraction technique was used applying delay times of 200–800 ns.

MALDI-TOF sample preparation

Positive mode

The polymer samples were dissolved in acetone (4 mg/mL, 50/50% vol). The sample solutions were mixed with a acetone solution (10 mg/mL in acetone) of the matrix. 2,5-dihydroxy benzoic acid was used as the matrix. For the enhancement of ion formation, NaCl was added to the matrix (10 mg/mL in water). The solutions of the sample and the matrix were mixed in the proportions 3 parts matrix solution + 3 parts polymer solution + 1 part NaCl solution and 0.5 to 1 μ L of the resulting solution mix were placed on the MALDI target. After evaporation of the solvent, the MALDI target was introduced into the spectrometer. The dry droplet sample preparation method was used.

Negative mode

The polymer samples were dissolved in acetone/water (4 mg/mL, 50/50% vol). The sample solutions were mixed with a tetrahydrofuran (THF) solution (10 mg/mL in acetone) of the matrix. Harmin was used as the matrix. The solutions of the sample and the matrix were mixed in equal proportions, and the resulting solution mixes were placed on the MALDI target. After evaporation of the solvent, the MALDI target was introduced into the spectrometer. The dry droplet sample preparation method was used.

RESULTS AND DISCUSSION

The oligomer types and oligomers distribution for the Blancotan BC syntan are derived from the positive ions MALDI-TOF spectra in Figure 1(a,b) and the negative ions spectra in Figure 2(a,b). In the positive ions spectra the main series of peaks is the 536 Da, 798 Da, and 1062 Da corresponding after subtracting 23 Da for the Na⁺ matrix additive to the oligomers of molecular weight 512, 774, and 1037. These are respectively the dimer, trimer, and

tetramer of the polycondensation reaction of 4,4'-dioxydiphenylsulfone with formaldehyde. Thus, the structure of the 1037 Da tetramer is

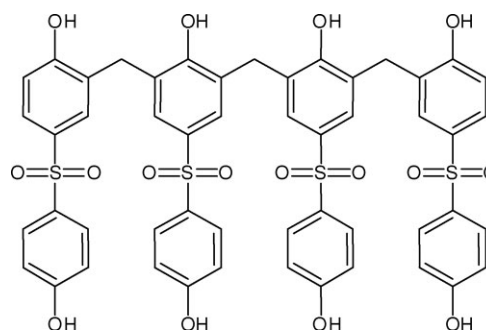

Formula Weight = 1037.1

Also visible is a small peak at 606 Da (a cluster at 601, 606, and 610 Da) that is instead the most abundant peak in the negative ions mode in Figure 2(a,b). In Figure 2(a,b) instead, the negative ions mode in which the peaks indicate directly the molecular mass of the oligomer without need to subtract 23 Da for the Na⁺, it is noticeable the series of peaks at 344 Da, 512 Da, 606 (601–610) Da, 700 Da, 794 Da, 869 Da, 963 Da, 1057 Da, 1131 Da, 1225 Da, and 1319 Da. These are a series of 4,4'-dioxydiphenylsulfone polycondensates with formaldehyde some presenting on their structure one, two, or three methylene sulfonic acid groups linked to the structure of the oligomer. The only oligomer that does not present a methylene sulfonic acid group is the one at 512 Da, the structure of which is identical to that of the dimer observed in Figure 1(a) at 536 Da. Thus, the series above corresponds to respectively methylenesulfonated monomer, dimer, monomethylenesulfonated dimer, dimethylenesulfonated dimer, trimethylenesulfonated dimer, monomethylenesulfonated trimer, diomethylenesulfonated trimer, trimethylenesulfonated trimer, monomethylenesulfonated tetramer, dimethylenesulfonated tetramer, and trimethylenesulfonated tetramer. An example of the formulas of the three trimers being:

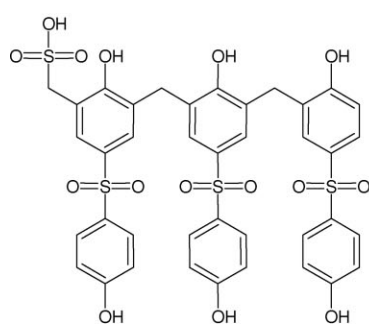

Formula Weight = 868.9

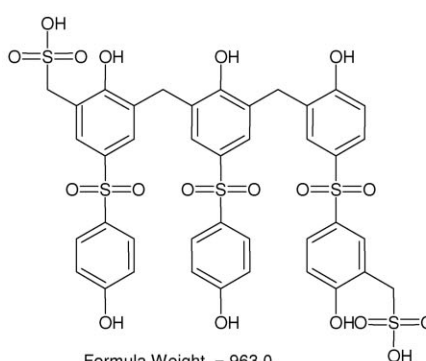

Formula Weight = 963.0

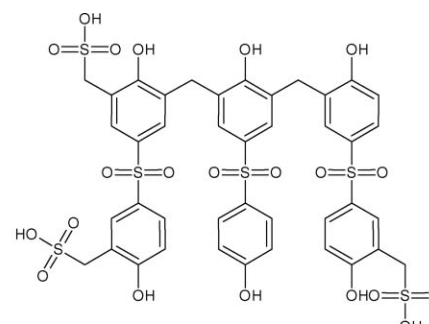

Formula Weight = 1057.1

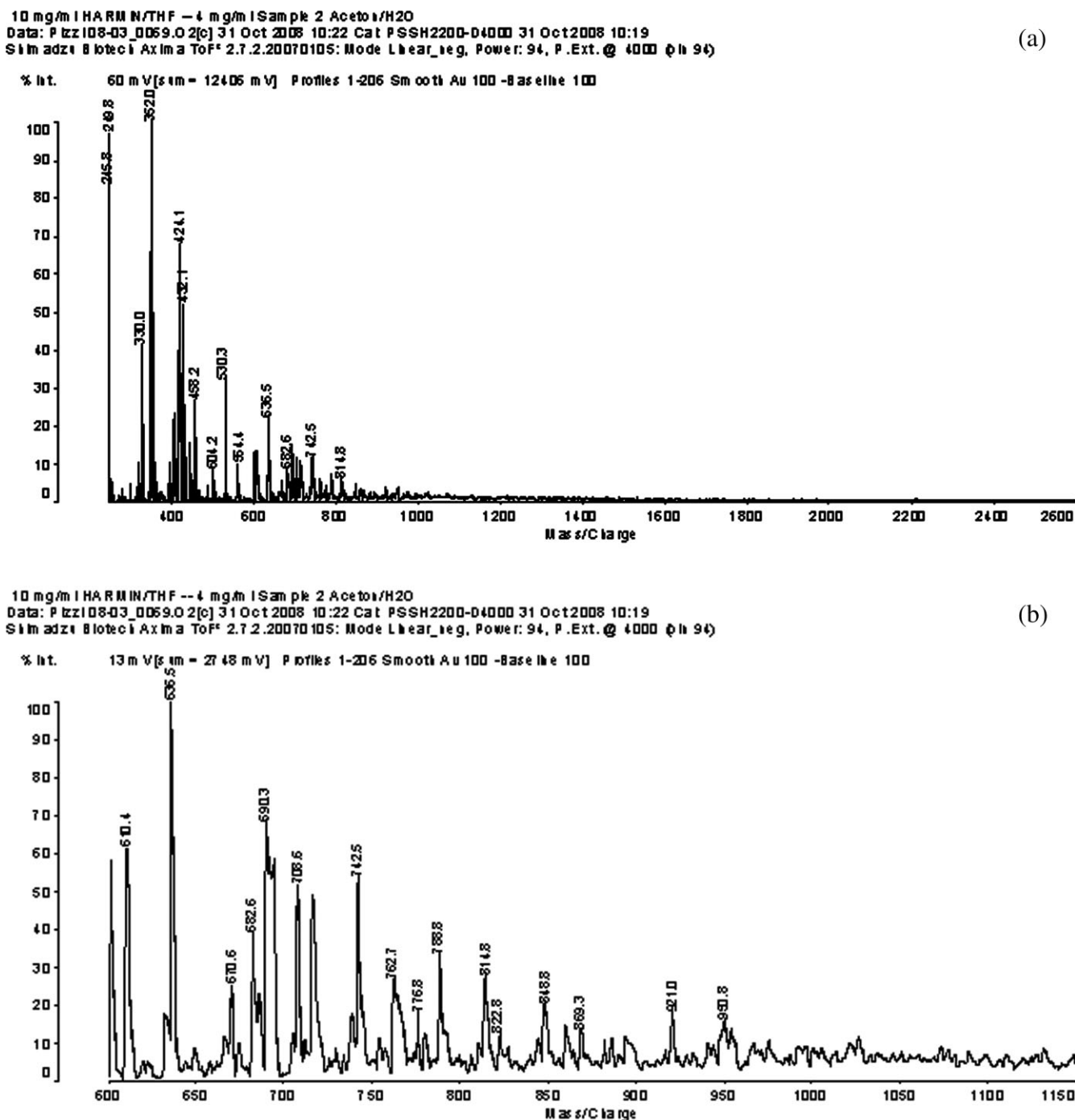
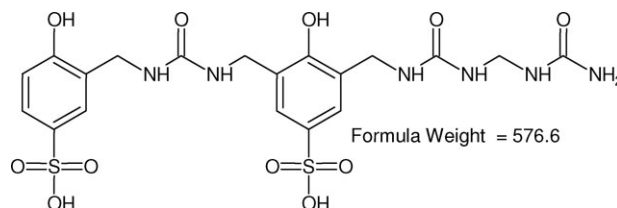

Figure 2 Negative ion mode MALDI-TOF mass spectrum of polycondensation oligomers of the reaction of sulfonated phenol and 4,4'-dioxydiphenylsulfone with formaldehyde and sodium bisulfite. (a) 400–2600 Da. (b) Details of the 600–1150 Da.

Even more interesting are the results of the polycondensates of sodium Blancotan HLF PC, a syntan formed by the cocondensation of sulfonated phenol, urea, and formaldehyde. These are cocondensation products with formaldehyde of sulfonated phenol and urea. In the positive ions mode in Figure 3, the main peak at 601 Da corresponds to a cocondensation pentamer of three ureas and two sulfonated phenols having structure



The peak at 483–485 Da corresponds to $\text{Ph}-\text{CH}_2-\text{U}-\text{CH}_2-\text{Ph}-\text{CH}_2\text{OH}$. The rest of the peaks

10 mg/ml DHB/Ace Ion -- 4 mg/ml Sample 3 Ace Ion/H2O - NaCl
 Data: F111 08-03_0050.M3[0] 300 Cl 2008 15:57 Cal: IofPE0+000+000 30 0 Cl 2008 15:42
 S/Nm adzu Blo ech Axims ToF: 2.7.2.0070 105: Mode Linear, Power: 113, P.Exl. @ +000 (bin 94)

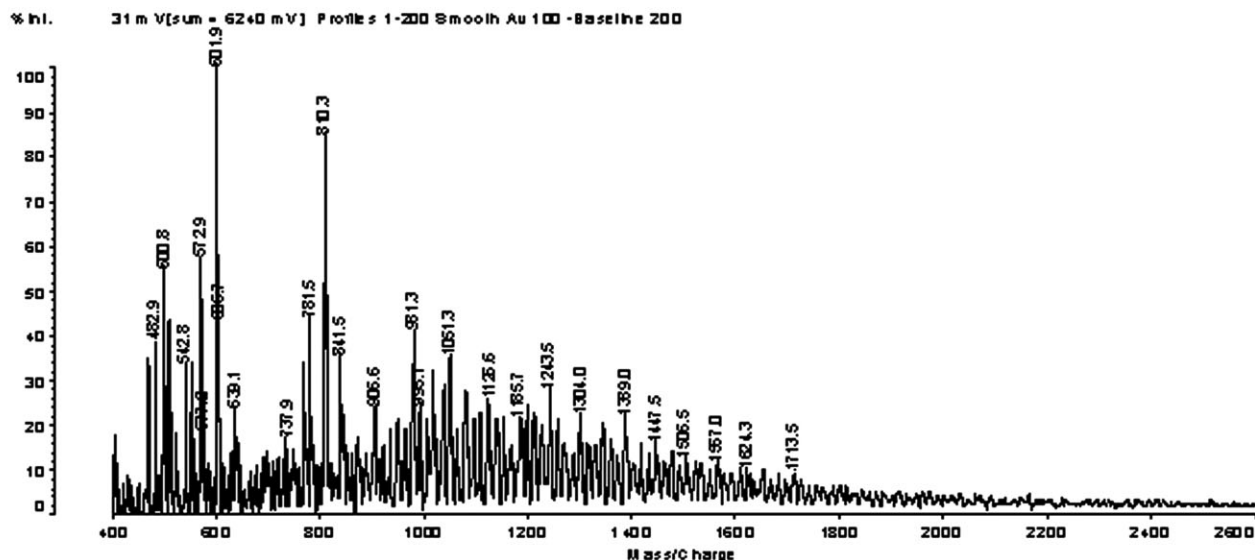

Figure 3 Positive ion mode MALDI-TOF mass spectrum of sodium salts of polycondensation oligomers from the reaction of phenol and sulfonated phenol with formaldehyde and urea.

TABLE I
Sodium Blancotan HLF and HLF/PC Oligomers

Peak Da	Method positive or negative ions	Relative proportion (%)	Oligomer type
246	Neg.	11	HO ₃ S-Ph-CH ₂ -NHCONH ₂
330	Neg.	7	(HO ₃ S) ₂ -Ph-CH ₂ -NHCONH ₂
(352)	Neg.	HLF)	HO ₃ S-Ph-CH ₂ -NHCONH-CH ₂ -Ph
(403)	Pos.	HLF)	⁻ O ₃ S-Ph-CH ₂ -NHCONH-CH ₂ -Ph-CH ₂ OH
408	Neg.	9	(HO ₃ S) ₂ -Ph-CH ₂ -NHCONH-SO ₃ H
422	Neg.	22	(HO ₃ S) ₂ -Ph-CH ₂ -NHCON(-CH ₂ ⁺)-SO ₃ H or HO ₃ S-Ph-CH ₂ -[NHCONH-CH ₂] ₂ -Ph
432	Neg.	18	HO ₃ S-Ph-CH ₂ -NHCONH-CH ₂ -Ph-SO ₃ H
(458)	Neg.	HLF)	HO ₃ S-Ph-CH ₂ -NHCONH-[CH ₂ -Ph] ₂
(475)	Pos.	HLF)	⁻ O ₃ S-Ph-CH ₂ -NHCONH-CH ₂ -Ph-CH ₂ -NHCONH-CH ₂ OH
483	Pos.		HO ₃ S-Ph-CH ₂ -NHCONH-CH ₂ -Ph(-SO ₃ H)-CH ₂ OH
504	Neg.	14	HO ₃ S-Ph-CH ₂ -NHCONH-CH ₂ -Ph(-SO ₃ H)-CH ₂ -NHCONH ₂ , or HO ₃ S-Ph-CH ₂ -NHCONH-CH ₂ -NHCONH-CH ₂ -Ph-SO ₃ H
(508)	Pos.	HLF)	⁻ O ₃ S-Ph-CH ₂ -NHCONH-[CH ₂ -Ph] ₂
(530)	Neg.	HLF)	HO ₃ S-Ph-CH ₂ -NHCONH-CH ₂ -Ph-CH ₂ -NHCONH-CH ₂ -Ph
(581)	Pos.	HLF)	⁻ O ₃ S-Ph-[CH ₂ -NHCONH] ₂ -[CH ₂ -Ph] ₂ -CH ₂ OH
601	Pos.		HO ₃ S-Ph-CH ₂ -NHCONH-CH ₂ -Ph(-SO ₃ H)-[CH ₂ -NHCONH-] ₂ -H
(636)	Neg.	HLF)	HO ₃ S-Ph-[CH ₂ -NHCONH] ₂ -[CH ₂ -Ph] ₃
(687)	Pos.	HLF)	⁻ O ₃ S-Ph-[CH ₂ -NHCONH] ₂ -[CH ₂ -Ph] ₃ -CH ₂ OH
690	Neg.	8	HO ₃ S-Ph-CH ₂ -NHCONH-CH ₂ -Ph(-SO ₃ H)-CH ₂ -NHCONH-CH ₂ -Ph-SO ₃ H, or all type H-NHCONH-CH ₂ -NHCONH-CH ₂ -[Ph(-SO ₃ H)] ₃
(759)	Pos.	HLF)	⁻ O ₃ S-Ph-[CH ₂ -NHCONH] ₃ -[CH ₂ -Ph] ₃ -CH ₂ OH
(742)	Neg.	HLF)	HO ₃ S-Ph-[CH ₂ -NHCONH] ₂ -[CH ₂ -Ph] ₄
763	Neg.	8	HO ₃ S-Ph-CH ₂ -NHCONH-CH ₂ -Ph(-SO ₃ H)-CH ₂ -[NHCONH-CH ₂] ₂ -Ph-SO ₃ H or all combinations type H[-NHCONH-CH ₂] ₂ -NHCONH-CH ₂ -[Ph(-SO ₃ H)] ₃
(814)	Neg.	HLF)	HO ₃ S-Ph-[CH ₂ -NHCONH] ₃ -[CH ₂ -Ph] ₄
(865)	Pos.	HLF)	⁻ O ₃ S-Ph-[CH ₂ -NHCONH] ₃ -[CH ₂ -Ph] ₄ -CH ₂ OH
942	Neg.	1.8	all combinations type H-[-NHCONH-CH ₂] ₃ -NHCONH-CH ₂ -Ph-CH ₂ -[Ph(-SO ₃ H)] ₃
(971)	Pos.	HLF)	⁻ O ₃ S-Ph-[CH ₂ -NHCONH] ₃ -[CH ₂ -Ph] ₅ -CH ₂ OH
1023	Neg.	1.2	all combinations type H-[-NHCONH-CH ₂] ₃ -NHCONH-CH ₂ -[Ph(-SO ₃ H)] ₄
(1077)	Pos.	HLF)	⁻ O ₃ S-Ph-[CH ₂ -NHCONH] ₃ -[CH ₂ -Ph] ₆ -CH ₂ OH
(1183)	Pos.	HLF)	⁻ O ₃ S-Ph-[CH ₂ -NHCONH] ₃ -[CH ₂ -Ph] ₇ -CH ₂ OH

The oligomers belonging only to HLF and not to HLF/PC are indicated between parenthesis. U: urea residue; Ph: phenol residue.

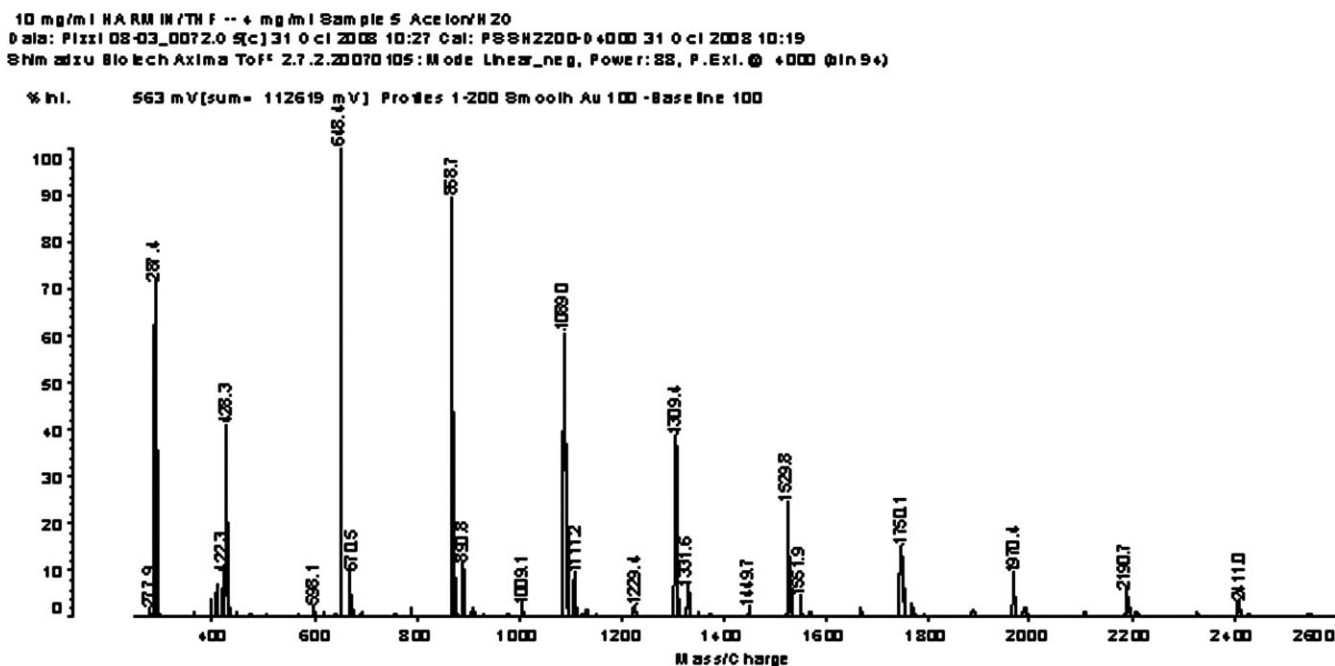

Figure 4 Negative ion mode MALDI-TOF mass spectrum of sodium/ammonium salts of polycondensation oligomers from the reaction of sulfonated naphthalene with formaldehyde.

are shown in Table I for both Blancotan HLF and Blancotan HLF PC. The series of phenol-urea-formaldehyde oligomers and of sulfonated phenol-urea-formaldehyde oligomers for these two syntans are shown in Table I. In general, a single sulfonic group per chain is present on these oligomers with the exception of the series of peaks at 690 Da ($3 \times -SO_3H$), 763 Da ($3 \times -SO_3H$), 942 Da ($3 \times -SO_3H$), and 1023 Da ($4 \times$

$-SO_3H$). As regards the oligomers dimension, oligomers up to seven phenolic rings and three urea residues linked together by methylene bridges are observed as well as oligomers up to four ureas with four phenols (1023 Da). The relative proportion of these oligomers as indicated in Table I shows that about 70% is constituted of trimers and higher oligomers of higher molecular mass, these being predominant in this tannin extract.

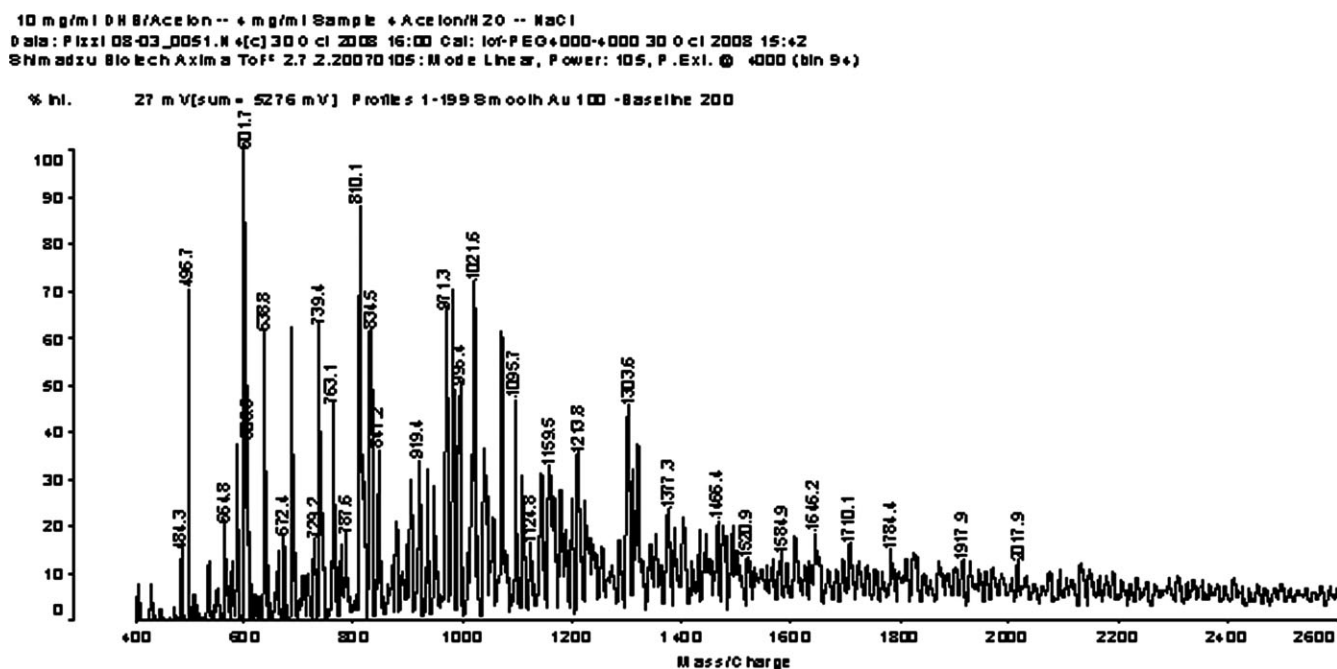

Figure 5 Positive ion mode MALDI-TOF mass spectrum of sodium/ammonium salts of polycondensation oligomers from the reaction of sulfonated naphthalene with formaldehyde.

TABLE II
Sodium and Ammonium Blancotan SN Oligomers

Peak Da	Method: positive or negative ions	Relative proportion (%)		Oligomer type
		Na	NH ₄	
428	Neg.	11.7	10.9	Naph-[CH ₂ -Naph(-SO ₃ H)-]
496	Pos.	-	-	HOCH ₂ -Naph-CH ₂ -Naph-CH ₂ ⁺
648	Neg.	30.9	26.0	Naph-[CH ₂ -Naph(-SO ₃ H)-] ₂
689	Pos.	-	-	Naph-[CH ₂ -Naph] ₂ -CH ₂ ⁺
717	Pos.	-	-	HOCH ₂ -Naph-[CH ₂ -Naph] ₂ -CH ₂ ⁺
868	Neg.	27.2	23.4	Naph-[CH ₂ -Naph(-SO ₃ H)-] ₃
1089	Neg.	16.1	13.5	Naph-[CH ₂ -Naph(-SO ₃ H)-] ₄
1310	Neg.	7.7	10.4	Naph-[CH ₂ -Naph(-SO ₃ H)-] ₅
1530	Neg.	3.7	6.8	Naph-[CH ₂ -Naph(-SO ₃ H)-] ₆
1751	Neg.	2.1	3.9	Naph-[CH ₂ -Naph(-SO ₃ H)-] ₇
1971	Neg.	0.6	2.6	Naph-[CH ₂ -Naph(-SO ₃ H)-] ₈
2190	Neg.	-	1.5	Naph-[CH ₂ -Naph(-SO ₃ H)-] ₉
2411	Neg.	-	1.0	Naph-[CH ₂ -Naph(-SO ₃ H)-] ₁₀

As regards, the syntans (sodium and ammonium Blancotan SN) these were prepared by the sulfonated product of the reaction of condensation of naphthalene with formaldehyde, the MALDI-TOF spectrum of which is shown in Figures 4 (negative ion mode) and 5 (positive ion mode). The series of peaks of the two compound are very similar and are both reported in Table II. The repeating motive in the spectra is of 220 Da. This is a monosulfonated naphthalene to which is linked a methylene bridge. The type of oligomers formed are shown in Table II. The main series of oligomers noted correspond to a succession of linear oligomers of up to 11 naphthalene units linked to each

other by methylene bridges, all repeating units being sulfonated, with the exception of the first one. The main series of oligomers can then be represented as having the following general structure

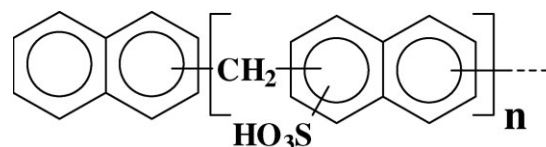

Where n is an integer number between 1 and 10 and where the sulfonic group is found both as

10 mg/ml HARM N/THF - 4 mg/ml Sample 20 Acetone/H2O
Data: P Lz108-03_0073.06[c] 31 Oct 2008 10:29 Cat P SS H2200-04000 31 Oct 2008 10:32
Silmadz 8 kV Tech Axima ToF 2.7 2.20070 10S: Mode L bear_neg, Power: 88, P.Ext. @ 4000 phi 9 phi

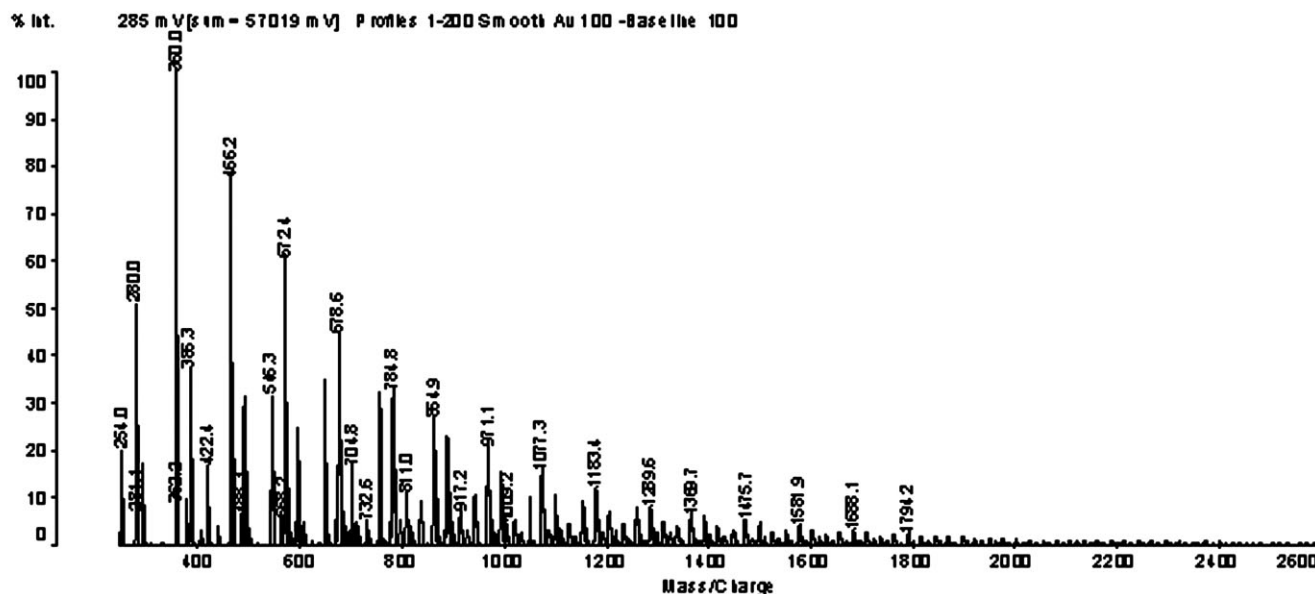

Figure 6 Negative ion mode MALDI-TOF mass spectrum of a sulfonated phenolic novolak resin syntan.

TABLE III
Sulfonated Phenol-Formaldehyde Novolak Oligomers of Syntan Blancotan PRV
Obtained by MALDI-TOF Negative Ion Mode

Peak Da	Method: negative ions. Relative proportion (%)	Oligomer type
254	3.4	HOCH ₂ -Ph(CH ₂ ⁺)-CH ₂ -Ph-CH ₂ -
360	16.3	HOCH ₂ -Ph(CH ₂ ⁺)-CH ₂ -[Ph-CH ₂ -] ₂ -
466	13.0	HOCH ₂ -Ph(CH ₂ ⁺)-CH ₂ -[Ph-CH ₂ -] ₃ -
546	5.4	HOCH ₂ -Ph(CH ₂ ⁺)-CH ₂ -Ph(-SO ₃ H)-CH ₂ -[Ph-CH ₂ -] ₂ -
572	10.1	HOCH ₂ -Ph(CH ₂ ⁺)-CH ₂ -Ph(-SO ₃ H)-CH ₂ -[Ph-CH ₂ -] ₃ -
652	5.9	HOCH ₂ -Ph(CH ₂ ⁺)-CH ₂ -[Ph(-SO ₃ H)-CH ₂] ₂ -[Ph-CH ₂ -] ₂ -
678	7.5	HOCH ₂ -Ph(CH ₂ ⁺)-CH ₂ -Ph(-SO ₃ H)-CH ₂ -[Ph-CH ₂ -] ₄ -
758	5.4	HOCH ₂ -Ph(CH ₂ ⁺)-CH ₂ -[Ph(-SO ₃ H)-CH ₂] ₂ -[Ph-CH ₂ -] ₃ -
784	5.4	HOCH ₂ -Ph(CH ₂ ⁺)-CH ₂ -Ph(-SO ₃ H)-CH ₂ -[Ph-CH ₂ -] ₅ -
864	4.4	HOCH ₂ -Ph(CH ₂ ⁺)-CH ₂ -[Ph(-SO ₃ H)-CH ₂] ₂ -[Ph-CH ₂ -] ₄ -
890	3.8	HOCH ₂ -Ph(CH ₂ ⁺)-CH ₂ -Ph(-SO ₃ H)-CH ₂ -[Ph-CH ₂ -] ₆ -
971	3.6	HOCH ₂ -Ph(CH ₂ ⁺)-CH ₂ -[Ph(-SO ₃ H)-CH ₂] ₂ -[Ph-CH ₂ -] ₅ -
996	2.6	HOCH ₂ -Ph(CH ₂ ⁺)-CH ₂ -Ph(-SO ₃ H)-CH ₂ -[Ph-CH ₂ -] ₇ -
1077	2.9	HOCH ₂ -Ph(CH ₂ ⁺)-CH ₂ -[Ph(-SO ₃ H)-CH ₂] ₂ -[Ph-CH ₂ -] ₆ -
1102	1.6	HOCH ₂ -Ph(CH ₂ ⁺)-CH ₂ -Ph(-SO ₃ H)-CH ₂ -[Ph-CH ₂ -] ₈ -
1183	2.3	HOCH ₂ -Ph(CH ₂ ⁺)-CH ₂ -[Ph(-SO ₃ H)-CH ₂] ₂ -[Ph-CH ₂ -] ₇ -
1208	1.1	HOCH ₂ -Ph(CH ₂ ⁺)-CH ₂ -Ph(-SO ₃ H)-CH ₂ -[Ph-CH ₂ -] ₉ -
1289	1.6	HOCH ₂ -Ph(CH ₂ ⁺)-CH ₂ -[Ph(-SO ₃ H)-CH ₂] ₂ -[Ph-CH ₂ -] ₈ -
1369	1.3	HOCH ₂ -Ph(CH ₂ ⁺)-CH ₂ -[Ph(-SO ₃ H)-CH ₂] ₃ -[Ph-CH ₂ -] ₈ -
1475	1.0	HOCH ₂ -Ph(CH ₂ ⁺)-CH ₂ -[Ph(-SO ₃ H)-CH ₂] ₃ -[Ph-CH ₂ -] ₁₀ -
1581	0.7	HOCH ₂ -Ph(CH ₂ ⁺)-CH ₂ -[Ph(-SO ₃ H)-CH ₂] ₃ -[Ph-CH ₂ -] ₁₁ -
1688	0.5	HOCH ₂ -Ph(CH ₂ ⁺)-CH ₂ -[Ph(-SO ₃ H)-CH ₂] ₃ -[Ph-CH ₂ -] ₁₂ -
1794	0.2	HOCH ₂ -Ph(CH ₂ ⁺)-CH ₂ -[Ph(-SO ₃ H)-CH ₂] ₃ -[Ph-CH ₂ -] ₁₃ -

-SO₃H and as -SO₃⁻. In both cases in Table II, the relative proportion of oligomers from trimers upward is of just under 90% of the total.

The last syntan, a sulfonated phenol-formaldehyde novolak, (MALDI-TOF Spectrum in Fig. 6) present the oligomers shown in Table III. This is composed of two main parallel main series. The first of these presents general structure:

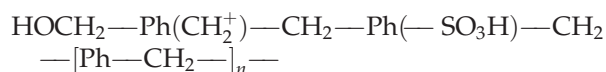

In which n = the sequence of integer numbers between 1 and 10, thus oligomers of up to 13 phenolic moieties. In this series of oligomers only one sulfonic group for each oligomer is present.

Parallel to this, there is the series of oligomers that are heavily sulfonated. Their general structure is

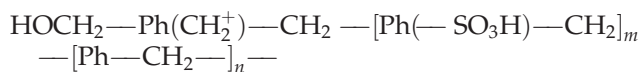

Where m is an integer number between 0 and 2, and n is an integer number between 1 and 9. Thus, for this series, oligomers of up to 12 phenolic rings are linked to each other by the methylene bridges

formed by reaction with formaldehyde. In Table III, the relative proportion of oligomers from trimers upward is of 96% of the total.

CONCLUSIONS

The structure of the six different syntans analyzed by MALDI-TOF indicated that the products obtained by commercial synthesis were composed of resin oligomers up to degrees of polymerization higher than what thought previously for these materials. The oligomers distribution indicated that the relative abundance of oligomers from trimer to higher degrees of polymerization varied from 70% to more than 90% according to the different syntans tested. Furthermore, these syntans are often composed of mixtures in which parallel series of sulfonated and nonsulfonated oligomers both occur.

References

1. Simon, C.; Pizzi, A. *J Am Leather Chem Assoc* 2003, 98, 83.
2. Simon, C.; Pizzi, A. *J Appl Polym Sci* 2003, 88, 1889.
3. Karas, M.; Bachmann, D.; Bahr, U.; Hillenkamp, F. *Int J Mass Spectrom Ion Processes* 1987, 78, 53.
4. Bahr, U.; Deppe, A.; Karas, M.; Hillenkamp, F.; Giessmann, U. *Anal Chem* 1992, 64, 2866.

5. Danis, P. O.; Karr, D. E.; Mayer, F.; Holle, A.; Watson, C. H. *Org Mass Spectrom* 1992, 27, 843.
6. Danis, P. O.; Karr, D. E. *Org Mass Spectrom* 1993, 28, 923.
7. Ehring, H.; Karas, M.; Hillenkamp, F. *Org Mass Spectrom* 1992, 27, 472.
8. Pasch, H.; Gores, F. *Polymer* 1995, 36, 1999.
9. Pasch, H.; Pizzi, A.; Rode, K. *Polymer* 2001, 42, 7531.
10. Pasch, H.; Pizzi, A. *J Appl Polymer Sci* 2002, 85, 429.
11. Oo, C. W.; Pizzi, A.; Pasch, H.; Kassim, M. J. *J Appl Polymer Sci* 2008, 109, 963.
12. Tondi, G.; Pizzi, A.; Pasch, H.; Celzard, A. *Polym Degrad Stab* 2008, 93, 968.
13. Pizzi, A.; Tondi, G.; Pasch, H.; Celzard, A. *J Appl Polymer Sci* 2008, 110, 1451.
14. Lei, H.; Du, G.; Pizzi, A.; Pasch, H. *J Appl Polymer Sci* 2008, 110, 1182.
15. Despres, A.; Pizzi, A.; Pasch, H.; Kandelbauer, A. *J Appl Polymer Sci* 2007, 1106, 106.
16. Lei, H.; Pizzi, A.; Despres, A.; Pasch, H.; Du, G. *J Appl Polym Sci* 2006, 100, 3075.

Structure moléculaire des tanins hydrolysables commerciaux par la spectrométrie de masse MALDI-TOF.

Auteurs: A.PIZZI, H.PASCH, K.RODE, S.GIOVANDO

J.Appl.Polymer Sci., 113 (6): 3847-3859 (2009)

Dans cette étude, nous avons déterminé la structure moléculaire de six tanins hydrolysables commerciaux à l'aide de la spectrométrie MALDI-TOF.

Il s'agit des tanins de châtaignier, de chêne, de tara, de sumac, de galle chinoise et de galle turque dont les différentes structures moléculaires ont été définies. Des produits de dégradation différents de ceux rapportés dans la littérature ont été observés. La combinaison des modes positif et négatif en MALDI-TOF a montré que la plupart des résidus galloyles proviennent de la chaîne de glucose. En particulier que les résidus de galloyle provient d'une structure de base de chaîne de glucose.

Des oligomères, comportant dans certains cas jusqu'à 16 ou 17 unités de glucose et presque totalement exempts de résidus galloyles, ont été observés.

Cela indique qu'il existe une très large distribution jusqu'à de très longues chaînes de galloyle glucose dans la plupart des tanins hydrolysables commerciaux.

Nous avons vu aussi que ces tanins commerciaux sont principalement composés de longues chaînes de galloyle glucose avec une répétition d'unités de di-, tri-, et pentagalloyl glucose présentes dans la même chaîne.

La présence de longues chaînes de glucose dépouillées de la plupart des résidus galloyles indique que leur liaison est réalisée par les résidus de glucose. Ainsi les tanins commerciaux de tara et de galle turque sont des oligomères principalement polygalliques avec jusqu'à huit résidus d'acide gallique liés les uns aux autres en une chaîne. Le tanin de sumac s'est révélé être un mélange plus complexe d'oligomères de glucose jusqu'à 13 unités répétitives.

A.PIZZI, H.PASCH, K.RODE, S.GIOVANDO, Polymer structure of commercial hydrolysable tanins by MALDI-TOF mass spectrometry, *J.Appl.Polymer Sci.*, 113 (6): 3847-3859 (2009)

Polymer Structure of Commercial Hydrolyzable Tannins by Matrix-Assisted Laser Desorption/Ionization-Time-of-Flight Mass Spectrometry

A. Pizzi,¹ H. Pasch,^{2,3} K. Rode,² S. Giovando⁴

¹ENSTIB-LERMAB, Nancy University, Epinal, France

²Analytical Department, Deutsche Kunststoff Institute, Darmstadt, Germany

³Polymer Institute, University of Stellenbosch, Stellenbosch, South Africa

⁴Silva Chimica, S. Michele Mondovì, Italy

Received 30 January 2009; accepted 6 March 2009

DOI 10.1002/app.30377

Published online 21 May 2009 in Wiley InterScience (www.interscience.wiley.com).

ABSTRACT: The structures of six commercial hydrolyzable tannins, chestnut, oak, tara, sumach, chinese gall, and turkey gall tannins have been examined by matrix-assisted laser desorption/ionization-time-of-flight (MALDI-TOF) mass spectrometry. Their oligomeric structures and structure distributions have been defined. Degradation products of rather different structure than what previously reported were present. Different galloyl glucose monomers were observed for chestnut and oak tannin extracts and in chinese gall gallotannin extract. Combination of positive- and negative-mode MALDI-TOF showed that most galloyl residues of the galloyl glucose chains were stripped from a skeletal glucose chain. Oligomers, in some cases up to 16 or 17 glucose units long, almost totally stripped of galloyl residues were observed. This indicated that a wide distribution up to very long galloylglucose chains exist in most commercial

hydrolyzable tannin extracts. This indicated that these commercial tannin extracts are mainly composed of long galloyl glucose chains of mixed di-, tri-, and pentagalloyl glucose repeating units being present in the same chain. The presence of long glucose chains where most of the galloyl residues have been stripped indicates that their linkage may be sugar residue to sugar residue. Commercial tara and turkey gall tannins have been shown to be mainly polygallic oligomers of up to eight gallic acid residues linked to each other in a chain. Commercial sumach extract revealed itself a more complex mixture of glucose oligomers up to 13 repeating units. © 2009 Wiley Periodicals, Inc. *J Appl Polym Sci* 113: 3847–3859, 2009

Key words: structure; hydrolyzable tannins; MALDI; oligomers distribution; chestnut; oak; tara; chinese gall; turkey gall; sumach

INTRODUCTION

Vegetable tannins have been used to tan leather either alone or accompanying other tanning agents for several thousand years. They are natural products obtained from plants and are very diffuse in the whole plant kingdom. The term natural vegetable tannins is used loosely to define two broad classes of chemical compounds of mainly phenolic nature, namely, condensed or polyflavonoid tannins and hydrolyzable tannins. To the recognized oligomeric nature of condensed tannins^{1–4} corresponds the mixed nature of hydrolyzable tannins in which predominantly nonpolymeric but also polymeric structures are present.^{2–5} Hydrolyzable tannins, including chestnut, tara, sumach, chinese gall, turkey gall, oak,

and some other commercial tannin extracts are of two types: (1) mixtures of sugars with oligomers of simple phenols such as gallic and digallic acids, and (2) ellagitannins mainly formed of esters of a sugar, mainly glucose, with gallic and digallic acids, and with more complex structures containing ellagic acid. Many studies on the structure of these tannins have been carried out and in general their structure is known.^{2–9} However, the structure of commercial, industrially extracted tannins appears to differ from what shown in the literature, the process of industrial extraction quite clearly changing the composition of the extract. Except for a very few articles on the structure of one major commercial hydrolyzable tannin extract, namely, chestnut wood tannin extract,^{2,5} the structure of the other commercial tannins has not been reported, especially the type of oligomers present and their distribution. Thus, studies on chestnut tannin extract,^{1,2} an ellagitannin, identified that its main constituents are castalagin (I) and vescalagin, positional isomers of identical 935 mass, composing, respectively, 14.2% and 16.2% by

Correspondence to: A. Pizzi (antonio.pizzi@enstib.uhp-nancy.fr).

mass of chestnut tannin and the structure of which is as follows.

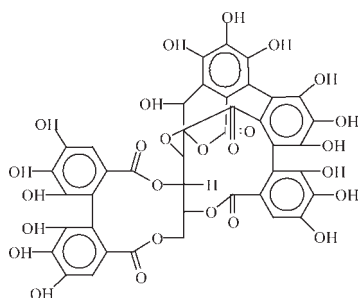

I

The rest of the tannin is composed of 6.6% castalin and vescalin (positional isomers of structure (II)),^{1,2} 6% gallic acid, and 3% pentagalloyl glucose monomer.

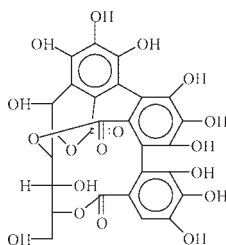

II

However, between 25 and 50%,^{1,5} is formed by a fraction that has been found to be a series of much higher molecular mass pentagalloyl glucose oligomers. The trimer of this was already identified.⁵ Previous work sustained that structures of type (I) and (II) were only degradation products of the original structure of the tannin.⁵

As different gallic and ellagic tannins exist and are sold commercially, this article concentrates on the structure of four of the most common commercial gallic tannins, namely, (1) tara, chinese gall, turkey gall, and sumach, and of two mixed commercial galloellagic tannins, namely, (2) chestnut and oak bark tannins.

Since its introduction by Karas and coworkers in 1987,¹⁰ matrix-assisted laser desorption/ionization (MALDI) mass spectrometry (MS) has greatly expanded the use of mass spectrometry toward large molecules and has revealed itself to be a powerful method for the characterization of both synthetic and natural polymers.^{11–17}

Fragmentation of analyte molecules on laser irradiation can be substantially reduced by embedding them in a light absorbing matrix. As a result, intact analyte molecules are desorbed and ionized along with the matrix and can be analyzed in a mass spectrometer. This soft ionization technique is mostly combined with time-of-flight (TOF) mass analyzers. This is so because TOF-MS presents the advantage

of being capable of providing a complete mass spectrum per event, for its virtually unlimited mass range, for the small amount of analyte necessary and the relatively low cost of the equipment.

MATERIALS AND METHODS

Tannin types

Six types of commercial hydrolyzable tannin extracts were used for MALDI-TOF analysis, namely, (1) Sumach (*Rhus coraria*) leaves commercial natural tannin extract, a gallotannin; (2) tara (*Caesalpinia spinosa*) tannin, solvent-extracted with ethylacetate/acetone/water to eliminate the sugar fraction, a commercial natural tannin extract, a gallotannin; (3) chinese gall, the abnormal growth (gall) produced by parasitic aphids of *Melaphis chinensis*; a commercial natural tannin extract, a gallotannin, it is obtained from the galls solvent-extracted with ethylacetate/acetone/water to eliminate the sugar fraction; (4) turkey gall, the growth (gall) on the stems and branches of certain oaks (*Quercus spp.*) produced by a wasp (*Cynips tinctoria*); a commercial natural tannin extract, a gallotannin, it is solvent-extracted with ethylacetate/acetone/water from the galls to eliminate the sugar fraction; (5) commercial chestnut (*Castanea sativa*) wood tannin, water-extracted, and cold-sulfited with 3.5% ammonium sulfite, a galloellagitannin; (6) commercial Oak (*Quercus spp.*) extract both water and solvent extracted. All these tannins were commercial tannins supplied by Silva Chimica (S.Michele Mondovi', Italy).

MALDI-TOF-MS

The spectra were recorded on a KRATOS Kompact MALDI AXIMA TOF 2 instrument (Kratos Analytical, Shimadzu Europe Ltd., Manchester, UK). The irradiation source was a pulsed nitrogen laser with a wavelength of 337 nm. The length of one laser pulse was 3 ns. The measurements were carried out by using the following conditions: polarity-positive, flight path-linear, mass-high (20 kV acceleration voltage), 100–150 pulses per spectrum. The delayed extraction technique was used applying delay times of 200–800 ns.

MALDI-TOF sample preparation

Positive mode

The polymer samples were dissolved in acetone (4 mg/mL, 50/50% volume). The sample solutions were mixed with an acetone solution (10 mg/mL in acetone) of the matrix. As matrix, 2,5-dihydroxy benzoic acid was used. For the enhancement of ion formation, NaCl was added to the matrix (10 mg/mL in water). The solutions of the sample and the matrix were mixed in the proportions of 3 parts matrix

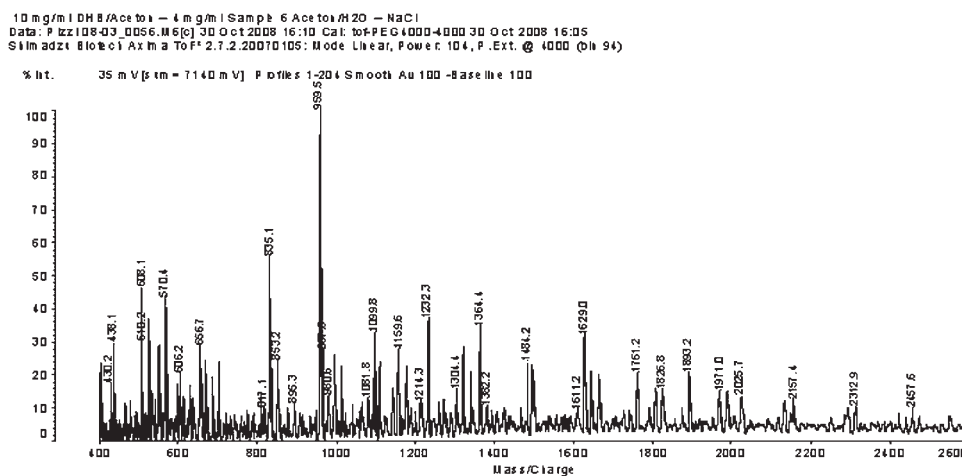

Figure 1 MALDI-TOF positive ion mode spectrum of water extracted chestnut tannin extract in the 400–2600 Da mass range.

solution + 3 parts polymer solution + 1 part NaCl solution and 0.5 to 1 μL of the resulting solution mix were placed on the MALDI target. After evaporation of the solvent, the MALDI target was introduced into the spectrometer by dry droplet sample preparation method. To each peak value in the resulting positive mode spectrum must be subtracted 23 Da of the Na^+ of the matrix to obtain the molecular weight of the chemical species of the peak.

Negative mode

The polymer samples were dissolved in acetone/water (4 mg/mL, 50/50% volume). The sample solutions were mixed with an tetrahydrofuran solution (10 mg/mL in acetone) of the matrix. As the matrix, Harmin was used. The solutions of the sample and the matrix were mixed in equal proportions and the resulting solution mix was placed on the MALDI target. After evaporation of the solvent, the MALDI

target was introduced into the spectrometer by dry droplet sample preparation method. The peak value in the resulting negative mode spectrum is the molecular weight of the chemical species of the peak, as the matrix used does not interfere.

RESULTS AND DISCUSSION

Different types of hydrolyzable tannins, namely, ellagitannins and gallotannins, exist. Gallotannins in their polygallic form are often simpler oligomeric structures derived by the polymerization of gallic and digallic acids. To the gallotannins belong sumach, tara, chinese gall, and turkey gall tannins. Chestnut and oak tannins instead are mixed gallic and ellagitannins.

A rather different structure and structure distribution became evident for commercial hydrolyzable tannins as shown by the chestnut tannin and oak tannin MALDI-TOF spectra in Figures 1–3. The

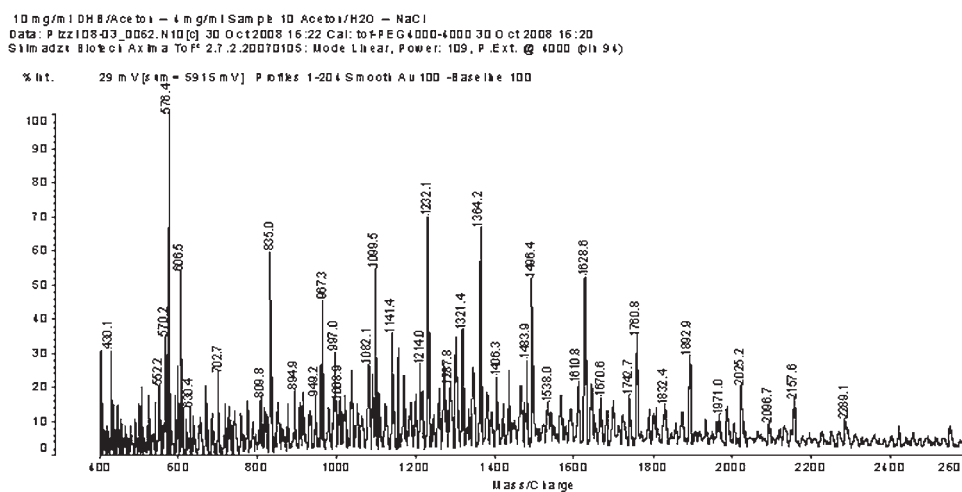

Figure 2 MALDI-TOF positive ion mode spectrum of water extracted oak tannin extract in the 400–2600 Da mass range.

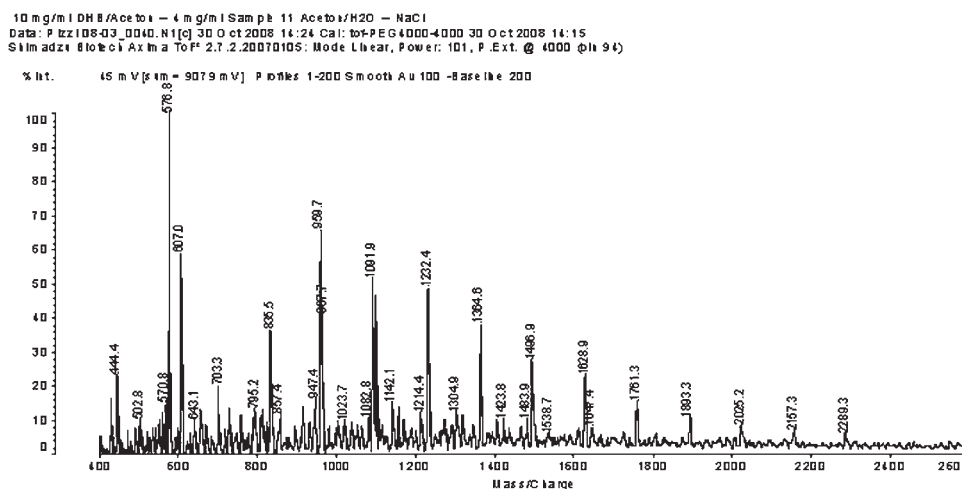

Figure 3 MALDI-TOF positive ion mode spectrum of solvent extracted oak tannin extract in the 400–2600 Da mass range.

structure of natural water-extracted chestnut tannin obtained by MALDI-TOF has already been reported.⁵ It was found to be composed of rearranged molecules such as castalagine and vescaline and predominantly of oligomers, up to trimers, of pentagalloyl glucose.⁵ With the exception of the previously unknown pentagalloyl glucose oligomers presence all that was found by MALDI-TOF corresponds to what was obtained by other methods of analysis.² However, a second commercial product is extensively used, namely, water-extracted chestnut tannin treated with 3.5% ammonium sulfite after extraction to improve solubility and hide penetration in leather making. It is this chestnut extract type the MALDI analysis of which is reported in this article. This material should show the same type of spectrum as reported previously.⁵ However, its MALDI spectrum in Figure 1 is rather different from that of natural chestnut tannin reported previously and presents a repeating motive of 132 Da. There is no possible gallic acid, digallic acid, galloyl, or ellagic acid residue that can correspond to such a repeating unit. It was finally realized that 132 Da is a monosaccharide glucose at 180 Da from which three hydroxy groups have been eliminated ($16 \times 3 = 48$; $180 - 48 = 132$ Da). Only 16 Da need to be subtracted because as the $-\text{OH}$ is lost an $-\text{H}$ is introduced on the same site of the molecule. This is then a glucopyranose ring residue from which any galloyl esters have been stripped. The alternative explanation that the 132-Da unit is formed by the loss of a HCHO molecule (30 Da) plus one molecule of water (18 Da) is possible but unlikely starting from the close pyranose ring configuration of glucose present in pentagalloyl glucose. Thus, the series of peaks present in Figure 1 corresponds to a series of glucoses oligomers up to 16 glucose residues long. To each of these oligomers is linked a single galloyl residue, one per

oligomer chain only. The only oligomers confirming that this was the original configuration of this tannin are the peaks at 508 Da (digalloylglucose) and at 656 Da (trigalloyl glucose) who are small but present in the spectrum. The sequence of peaks corresponding to these long carbohydrate chains observed in Figure 1 starts with the 438-Da peak (1 galloyl residue + 2 glucose residues stripped of $-\text{OH}$ s, the 132 Da repeating unit). Every peak that follows adds a further galloyl-residues-stripped glucose repeating unit. Thus, starting from the 438-Da peak one can observe a series of peaks as listed in Table I.

These are not hemicelluloses or cellulose fragments; if this was the case, the repeating unit would be of 178–180 Da, and this is not the case.

This result is unexpected and merits discussion in depth. In MALDI-TOF, one can obtain positive ions and negative ions spectra. The one shown in Figure 1 is the positive ions spectrum. The negative ions spectrum is shown in Figure 4. The only two peaks of any note that are observed in Figure 4 are those of ellagic acid at 302 Da (negative ion peaks are not subtracted of the 23 Da for Na^+ , as a different matrix is used) or of a digallic acid residue, and the peak at 483.5 Da, an ellagic or digallic acid residue linked to a glucose. There are traces of a couple of other compounds. These are at 631.5 Da, a monomer composed of a glucose to which are linked an ellagic acid residue and a gallic acid residue, and traces of pentagalloyl glucose at 933 Da. The 1086-Da peak indicates the presence of traces of a pentagalloyl glucose, to one of the galloyl residues of which is linked a sixth galloyl residue stripped from another pentagalloyl glucose. In fact, only the 300- to 302-Da peaks corresponding to ellagic or digallic acid residues appear in the negative mode spectrum after the galloellagic esters have been detached from pentagalloyl glucose.

TABLE I
Percentage Distribution of the Different Oligomers Present in Commercial Chestnut Extract
(from MALDI-TOF Positive Ion Mode Spectra)

Da	Peak intensity	Relative abundance (%)	
438	32	5.3	1 Galloyl residue + 2 stripped glucose residues = dimer
508	48	7.9	Digalloyl glucose, monomer
570	44	7.3	1 Galloyl residue + 3 stripped glucose residues = trimer
657	30	5.0	Trigalloyl glucose, monomer
835	58	9.6	1 Galloyl residue + 5 stripped glucose residues = pentamer
959	100	16.5	Pentagalloyl glucose, monomer
967	30	5.0	1 Galloyl residue + 6 stripped glucose residues = hexamer
1099	34	5.6	1 Galloyl residue + 7 stripped glucose residues = heptamer
1232	38	6.3	1 Galloyl residue + 8 stripped glucose residues = octamer
1364	34	5.6	1 Galloyl residue + 9 stripped glucose residues = nonamer
1496	23	3.8	1 Galloyl residue + 10 stripped glucose residues = decamer
1629	35	5.8	1 Galloyl residue + 11 stripped glucose residues = undecamer
1761	22	3.6	1 Galloyl residue + 12 stripped glucose residues = dodecamer
1893	22	3.6	1 Galloyl residue + 13 stripped glucose residues = tridecamer
2025	14	2.3	1 Galloyl residue + 14 stripped glucose residues = tetradecamer
2157	14	2.3	1 Galloyl residue + 15 stripped glucose residues = pentadecamer
2289	13	2.2	1 Galloyl residue + 16 stripped glucose residues = hexadecamer
2312	14	2.3	2 Galloyl residues + 15 stripped glucose residues = pentadecamer

In previous work natural chestnut tannin extraction appeared to cause tannin rearrangement to products such as castalagine/vescalagine and castaline/vescaline.⁵ The presence of pentagalloylglucose trimers constituted up to 60% of the extract. This indicated that extraction may cause the cleavage of longer pentagalloylglucose chains. This implied the rather novel concept that such a tannin is present, *in situ* in the wood, as a pervasive and extended random tridimensional macromolecular network of pentagalloylglucose chains, capable of being extracted exclusively by its degradation.⁵ The MALDI-TOF spectra in Figures 1 and 4 appear to support such a hypothesis. The cleavage and elimination of the galloyl ester residues from the spectrum then shows the full length of the skeletal glucose chain on which

these were originally linked. This occurs because the glucose chains, once stripped of their galloyl residues, are within the range of masses observable by the MALDI-TOF technique. It indicates that pentagalloylglucose oligomers of up to 16 repeating units are present in this commercial tannin extract. This supports the hypothesis that such a tannin may be present in the wood as an extended macromolecular chain.⁵ The only oligomers in Figure 1 confirming that this is the correct interpretation, and the original configuration of this tannin, are the peaks at 508 Da (digalloylglucose = $23 (\text{Na}^+) + 152 \times 2 + 180 = 507$ Da), at 656 Da (trigalloylglucose, 657 Da) who are small but nonetheless present, and the dominant 960-Da peak of pentagalloyl glucose itself ($23 (\text{Na}^+) + 152 \times 5 + (180 - 3) = 960$ Da). The series of

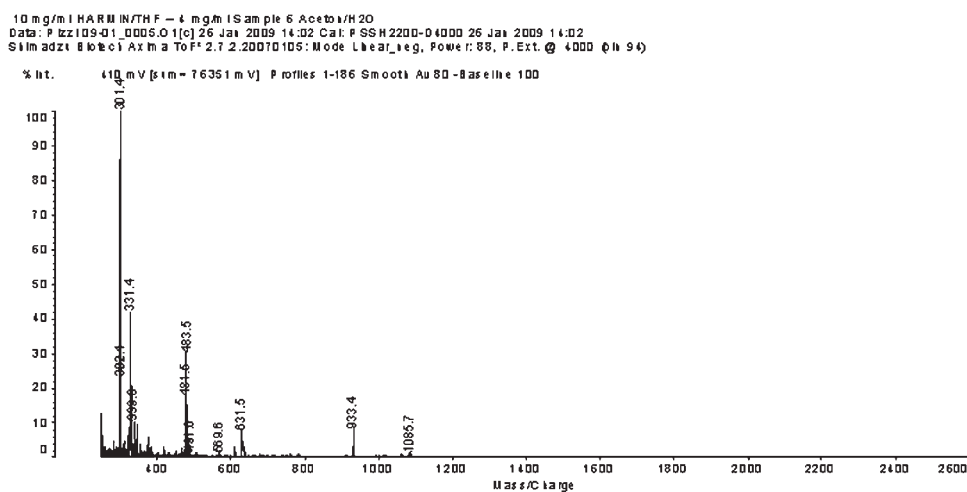

Figure 4 MALDI-TOF negative ion mode spectrum of water extracted chestnut tannin extract in the 400–2600 Da mass range.

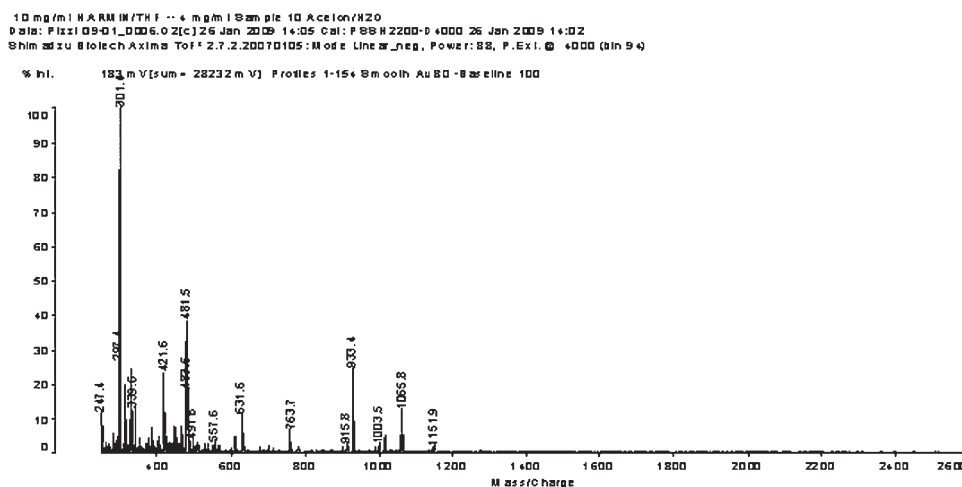

Figure 5 MALDI-TOF negative ion mode spectrum of water-extracted oak tannin extract in the 400–2600 Da mass range.

oligomers present in this tannin derived from the MALDI-TOF spectrum in Figure 1 are shown in Table I.

The same characteristics are noted in Figures 2 and 3 showing the MALDI-TOF spectrum for water-extracted and solvent extracted oak tannin. The pattern in Figure 3 of the solvent-extracted oak tannin is the clearer one. The predominant repeating unit is again 132 Da; hence, glucose stripped of its $-OH$ groups and of its five galloellagic residues. The single pentagalloylglucose peak at 960 Da is again present and is the second most intense one. To this is associated the 1091-Da peak formed by one stripped glucose residue linked to the pentagalloyl glucose. In this spectrum (Fig. 3), however, the dominant peaks are the 577-Da and its associated 607-Da peak. These are, respectively, a glucose trimer in which the $-OH$ at the C6 has been stripped but the $-CH_2^+$ still remains attached (577 Da) and the same glucose trimer where another complete C6 group ($-CH_2OH$) is still attached. The series of peaks is then 703 Da (three glucoses linked to a single galloyl residue), and a series of oligomers at 836, 968, 1100, 1232 (dominant of this series), 1364, 1496, 1628, 1761, 1893, 2025, 2157, and 2289 Da. Thus, one galloyl residue linked to a chain of 15 glucoses. In the water-extracted oak tannin in Figure 2 even a small 2421-Da peak is present. This corresponds to a 16-glucoses oligomer. The negative ion mode MALDI-TOF spectrum of the water-extracted oak tannin is shown in Figure 5. The trend is the same as in Figure 4: only monomeric species stripped from the main sugar chain shown in the positive ion mode in Figure 2 are present. The series of oligomers present in this tannin derived from the MALDI-TOF spectrum in Figure 3 are shown in Table II.

Thus, the structures that can be proposed for the main constituents of these two galloellagic hydrolyzable tannins is that of mixtures of oligomers up to 15

to 16 repeating units. The original repeating unit of these is pentagalloyl glucose (**I**). However, industrial extraction has also subtracted or hydrolyzed some galloyl residues from the main chain. Its appearance then is that of a mix of digalloyl, trigalloyl, and pentagalloyl glucoses linked together in oligomers 15 to 16 repeating units long, structure (**III**), where n varies between 1 and 16. These galloyl residues are still present in the extract, they are part of it.

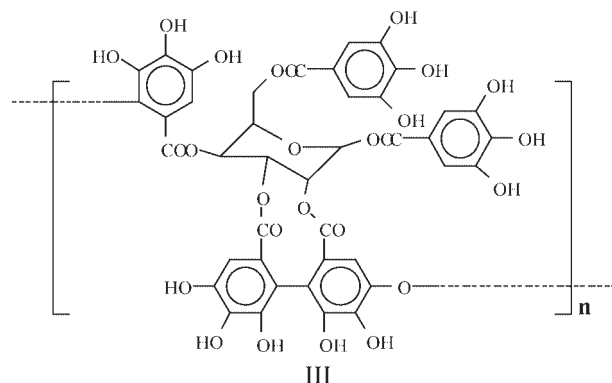

The implication of this is that the repeating units in galloyl glucose chains may be linked differently to each other and then according to the accepted model of structure (**III**).^{5,18,19} This is clear as in the positive mode spectrum the long glucose chains are linked to each other also when galloyl residues have been stripped away. Carbohydrates polymerization has been shown not to occur in MALDI-TOF; thus a different system of linkage than what was envisaged in structure (**III**) must be present.

In Figures 6–9 are shown the positive ion mode MALDI-TOF spectra of the four gallotannins analyzed. Sumach tannin (Fig. 6) extract is a polygallic tannin and its MALDI-TOF spectrum shows some major series of peaks exhibiting a mass increment of 152 Da (Fig. 6). This corresponds to what is known

TABLE II
Percentage Distribution of the Different Oligomers Present in Commercial Oak Tannin Extract
(from MALDI-TOF Positive Ion Mode Spectra)

Da	Peak intensity	Relative abundance (%)	
570	17	3.1	1 Galloyl residue + 3 stripped glucose residues = trimer
576	100	18.2	Unknown
703	22	4.0	1 Galloyl residue + 4 stripped glucose residues = tetramer
835	38	6.9	1 Galloyl residue + 5 stripped glucose residues = pentamer
959	67	12.2	Pentagalloyl glucose, monomer
967	45	8.2	1 Galloyl residue + 6 stripped glucose residues = hexamer
1092	55	10.0	1 Galloyl residue + 7 stripped glucose residues = heptamer
1232	52	9.4	1 Galloyl residue + 8 stripped glucose residues = octamer
1364	40	7.3	1 Galloyl residue + 9 stripped glucose residues = nonamer
1496	31	5.6	1 Galloyl residue + 10 stripped glucose residues = decamer
1628	27	4.9	1 Galloyl residue + 11 stripped glucose residues = undecamer
1761	17	3.1	1 Galloyl residue + 12 stripped glucose residues = dodecamer
1893	14	2.5	1 Galloyl residue + 13 stripped glucose residues = tridecamer
2025	12	2.1	1 Galloyl residue + 14 stripped glucose residues = tetradecamer
2157	8	1.5	1 Galloyl residue + 15 stripped glucose residues = pentadecamer
2289	6	1.1	1 Galloyl residue + 16 stripped glucose residues = hexadecamer

as regards the structure of this tannin. The repeat unit is structure (IV)

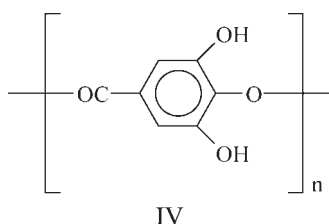

However, some differences from this are evident in Figure 6. The first interpretable peak for this tannin is at 508 Da. This corresponds to a glucose to which are linked two gallic acid residues ($23(\text{Na}^+) + 180 + 152 + 152 = 507$ Da). Three different series of oligomer peaks are present.

The series of oligomers in the highest proportion starts with the 924-Da peak (Fig. 6). This oligomer corresponding to this peak is exclusively composed of a chain of five glucoses ($23(\text{Na}^+) + 180 \times 5 = 923$ Da). The series continues with the peaks at 1076, 1229, 1381, 1532, 1684, 1836, and 1988 Da, thus adding one by one gallic acid 152 Da repeating units. It is not possible to assume that the peaks of the series represent linear chains of 1, 2, 3, 4, 5, 6, and 7 gallic acid residues attached to one of the glucoses only. It is more likely that the gallic acid residues are linked as single gallic residues or dimers or trimers to each of the five glucoses of the oligomer chain.

The closest interpretation of the 540-Da peak is based on two glucoses and a gallic acid residue ($23(\text{Na}^+) + 180 + 180 + 152 = 535$ Da). It is not possible to determine how these are linked with each other.

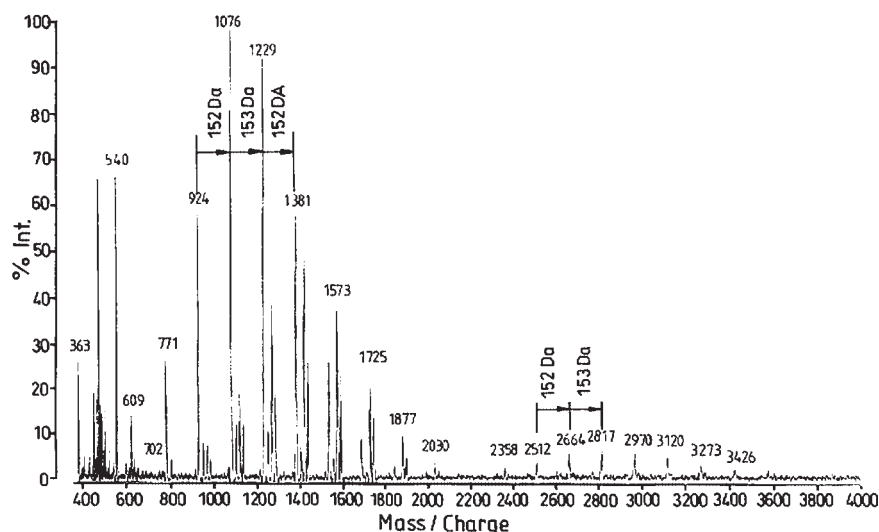

Figure 6 MALDI-TOF positive ion mode spectrum of water extracted sumach tannin extract in the 400–2600 Da mass range.

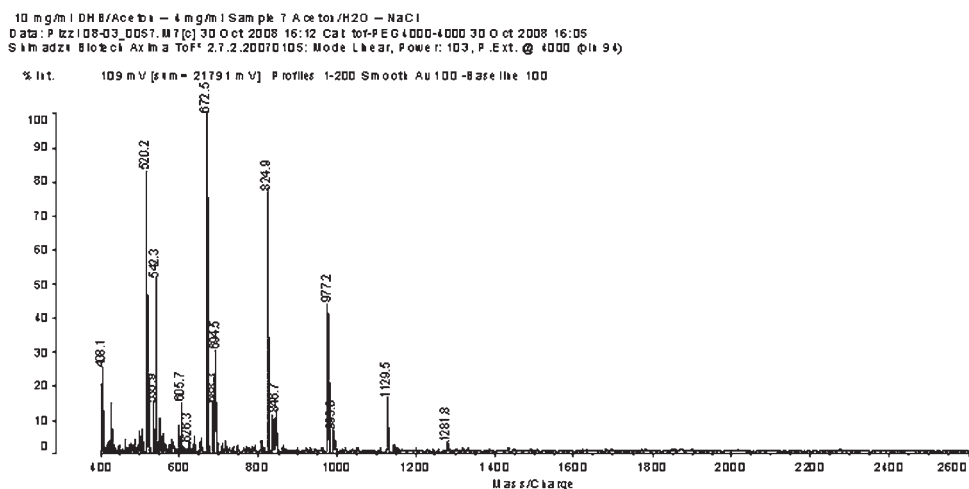

Figure 7 MALDI-TOF positive ion mode spectrum of solvent extracted tara tannin extract in the 400–2600 Da mass range.

The second series in the second highest proportion is the 508-, 965-, 1117-, 1269-, 1421-, 1573-, 1725-, 1877-, and 2030-Da series. The peaks correspond to a single glucose linked respectively to two gallic acid residues (508 Da), six gallic acid residues (965 Da), and so on up to a single glucose linked to 13 gallic acid residues (2030 Da). This clearly identifies them as polygallic acid chains of type (IV) because only one glucose is present in each of these oligomers. A chain of nine polygallic acid residues linked to a single glucose is the predominant oligomer in this series (at 1421 Da). It is interesting to note that in this series one passes from the gallic acid dimer linked to a glucose directly to the hexamer and higher oligomers, without any trimers, tetramers, or pentamers being present.

The third pattern, the least abundant, also presents a repeating unit of 152 Da. This is the series of peaks at 2358, 2512, 2664, 2817, 2970, 3120, 3273, and 3426 Da. These are higher oligomers, but notwithstanding the regular 152-Da increment are difficult to interpret. This series does not derive from any of the other two already described. Thus, the peak at 2358 does not derive from any peak of the other two series. The only correspondence is that it is formed by a glucose (or other sugar residue) oligomer of 13 repeating units ($23(\text{Na}^+) + 180 \times 13 = 2363$ Da). To these are attached seven gallic acid residues either as gallic acid oligomers or as monomers or dimers. The gallic acid residues are most likely linked as single gallic residues to each of the glucoses of the glucose oligomer chain, as for the first series.

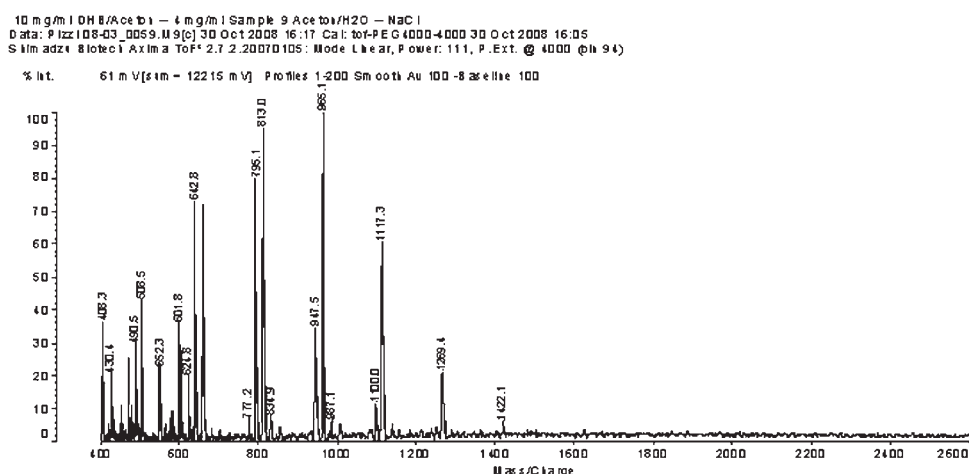

Figure 8 MALDI-TOF positive ion mode spectrum of solvent extracted turkey gall tannin extract in the 400–2600 Da mass range.

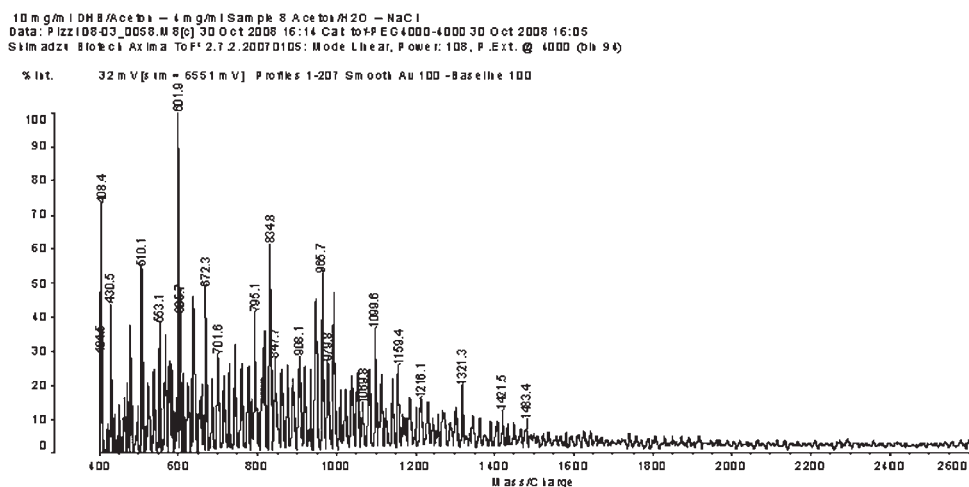
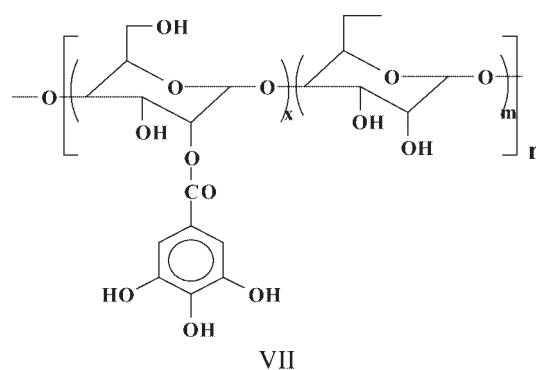
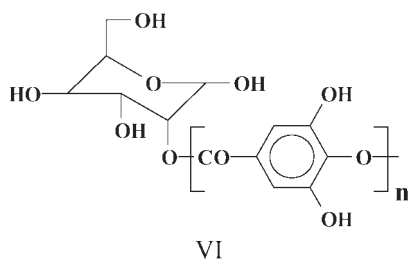
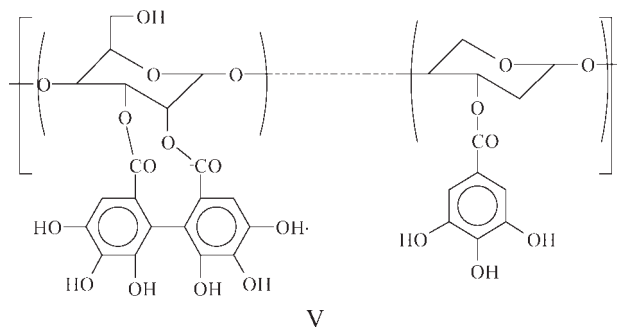

Figure 9 MALDI-TOF positive ion mode spectrum of solvent extracted Chinese gall tannin extract in the 400–2600 Da mass range.

Thus, according to the positive ions mode MALDI-TOF analysis, commercial sumach tannin extract is then composed of three types of oligomers. These are as follows:

1. The pattern of peaks in highest relative proportion corresponding to structure (V) composed of five sugar residues and up to seven galloyl residues.
2. The pattern of peaks in the second highest relative proportion responding to structure (VI), with $n = 2-13$.
3. The third and minor series of peaks corresponding to structures of type (VII), where $m = 6-13$, $x = 13 - m$, $n = x + m$.



The relative abundance of the oligomers corresponding to these three patterns is shown in Table III.

The spectra of the solvent extracted tara and turkey gall tannins are shown in Figures 7 and 8. Solvent extraction has eliminated the carbohydrates in the extract; thus, the polymeric nature of these two tannins can be clearly observed. The repeating unit observed is 152 Da, as for sumach, and corresponds to the same basic structure (IV) indicated for sumach extract. In the case of tara tannin this is known to contain small amounts of ellagic acid and a much greater proportion of gallic acid.⁶ The MALDI-TOF in Figure 7 confirms this finding. Thus, the second dominant peak at 520 Da ($23 (\text{Na}^+) + (302 - 1\text{H}) + 152 + 44 = 520$ Da) indicates an oligomer formed by one ellagic acid linked to one gallic acid, although the presence of an additional $-\text{COO}^-$ cannot be easily explained. The peaks at 672, 824, 977, 1129, 1281 Da indicate then a series of oligomers each formed by adding a gallic acid residue to the basic structure of the 520-Da peak. Thus, the number of gallic acid total residues indicates a series of polygallic trimers, tetramers, pentamers, hexamers, heptamers, and

TABLE III
Percentage Distribution of the Different Oligomers Present
in Commercial Sumach Extract

Da	Peak intensity	Relative abundance (%)	
540	67	9.45	Dimer
Pattern 1 (all glucose pentamers)			
924	60	8.45	Glucose pentamer
1076	100	14.1	Monogalloyl glucose pentamer
1229	92	12.9	Digalloyl glucose pentamer
1381	58	8.2	Trigalloyl glucose pentamer
1532	28	3.9	Tetragalloyl glucose pentamer
1684	10	1.4	Pentagalloyl glucose pentamer
1836	4	0.6	Hexagalloyl glucose pentamer
1988	1	0.15	Heptagalloyl glucose pentamer
	Total pattern 1	50.55	
Pattern 2			
508	66	9.2	Digalloyl glucose
965	8	1.1	Hexagalloyl glucose (hexamer)
1117	20	2.8	Heptagalloyl glucose (heptamer)
1269	40	5.6	Octagalloyl glucose (octamer)
1421	48	6.8	Nonagalloyl glucose (nonamer)
1573	40	5.6	Decagalloyl glucose (decamer)
1725	23	3.2	Undecagalloyl glucose (undecamer)
1877	10	1.4	Dodecagalloyl glucose (dodecamer)
2030	4	0.6	Tridecagalloyl glucose (tridecamer)
	Total pattern 2	35.4	
Pattern 3			
2358	2	0.3	Glucose tridecamer
2512	4	0.6	Monogalloyl glucose tridecamer
2664	5	0.7	Digalloyl glucose tridecamer
2817	7	1.0	Trigalloyl glucose tridecamer
2970	6	0.8	Tetragalloyl glucose tridecamer
3120	4	0.6	Pentagalloyl glucose tridecamer
3273	3	0.4	Hexagalloyl glucose tridecamer
3426	1	0.15	Heptagalloyl glucose tridecamer
	Total pattern 3	4.6	
Total		100	

octamers starting from the 520-Da peak. Their relative abundance is 26, 29, 23, 14.5, 6, and 1.5%, respectively. Oligomers smaller than trimers do not appear to occur.

A similar repeating unit pattern (152 Da) is observed for the positive ions mode MALDI-TOF of turkey gall tannin (Fig. 8). In this tannin the first interpretable peak is at 508 Da. This corresponds to a glucose to which are linked two gallic acid residues ($23(\text{Na}^+) + 180 + 152 + 152 = 507$ Da). It is not possible to know if the two gallic acid residues are separately linked to the glucose or if this is a digallic acid residue linked to the glucose. This latter appears to be the most probable configuration. It means that the 508-Da peak is a gallic acid dimer and the series of peaks at 661, 813, 965, 1117, 1269, and 1422 Da represent a series of gallic acid trimers, tetramers, pentamers, hexamers, heptamers, and octamers, all attached to one glucose. The peak at 642 Da is the 661 peak minus an $-\text{OH}$, thus also a

glucose + a gallic acid trimer. The same is valid for the peak at 795 Da, which is the 813-Da peak minus an $-\text{OH}$ group, thus a glucose + a gallic acid tetramer. Due to their relative abundance, these two peaks (642 and 795 Da) must also be taken into account in calculating the relative proportion of the oligomers present in turkey gall tannin. Thus, from the spectra in Figure 8 the respective abundance is of 8% (digalloyl glucose, dimers), 26% (monoglucose galloyl trimers), 32% (monoglucose galloyl tetramers), 18% (monoglucose galloyl pentamers), 11% (monoglucose galloyl hexamers), 3.5% (monoglucose galloyl heptamers), and 1.3% (monoglucose galloyl octamers).

It must also be kept in mind that while the repeating unit molecular weight is 152 Da, residues of quinic acid linked in the chain can also be present. Quinic acid is known to be present and included in some manner in the gallic acid chains of tara tannin.⁶⁻⁸ It appears to be linked in the chain in the

same manner as gallic acid (III), hence slightly differently than what was proposed in previous work.^{7,8}

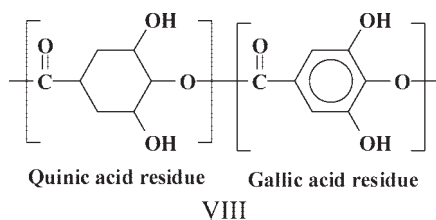

The same could apply to turkey gall tannin, although presence of quinic acid in the chain of this tannin has not been reported. Thus, this tannin must be still considered as a purely polygallic tannin linked to some glucose. This type of configuration is rather different from that proposed for residual quinic acid gallotannins (mainly tara) by previous authors.^{7,8}

The repeating unit pattern is different, however, for the chinese gall tannin (Fig. 9). Here the repeating unit is 162 Da. Thus, the series of peaks that can be seen responding to this pattern is the series 510, 623, 834, 996, 1159, 1321, and 1483 Da. Such an unusual repeating unit can have two explanations. In one case this can correspond to a quinic acid that is linked to other different quinic acid chains through its hydroxy groups as reported in much earlier work for tara tannin,⁷ and in a manner different to that reported for structure (VIII). Thus, quinic acid, where the $-OR_{1,2}$ are hydroxygroups, has a molecular weight of 168 Da; if one hydrogen is substituted with a gallic acid residue such as R_1 , then the total weight is of 168 Da - 1H + 152 + 1H Da = 320 Da. This is close enough to 162 Da \times 2 = 324 Da, the real repeating unit of the MALDI-TOF spectrum in Figure 9. Such an approach, however, cannot explain the multirepeating 162-Da pattern. This indicates that such an explanation is incorrect. Furthermore, the presence of quinic acid has never been reported in chinese gall tannins.

The second, more acceptable explanation is closer to what is already known on chinese gall tannin, namely, its composition of esters of gallic and digallic acid with glucose. Thus, two gallic acid residues attached to a glucose yield a repeating unit of [(180 - 1H Da) + 152 Da + (152 + 1 Da)] = 484 Da (similar to 162 Da \times 3 = 486 Da). It cannot be determined if this is a digallic acid linked to glucose or two gallic acid residues each linked independently to glucose. This appears then to be the real repeating unit of the oligomers. The oligomeric structure of commercial chinese gall tannin is then rather different to what is observed for turkey gall tannin. The repeating unit appears to be either structure (IX) or most likely structure (X)

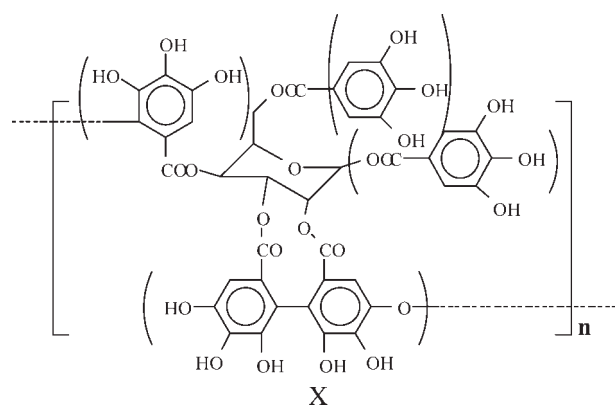
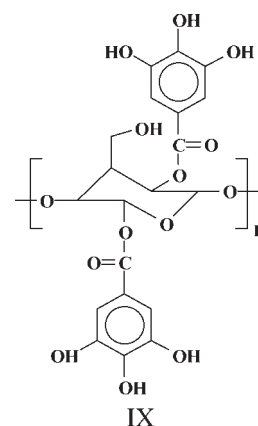

where the parentheses indicate the manner in which the two (only) gallic acid residues can be attached to the glucose residue. Thus, the repeating units are formed by digalloyl glucose if the structure is interpreted on the basis of the MALDI-TOF-positive ion mode spectrum in Figure 9. It has been reported in the literature⁷ that all the hydroxyl groups of chinese gall tannin are substituted by galloyl residues and thus that the repeating unit should be pentagalloyl glucose. The positive ion mode MALDI-TOF analysis of the commercial chinese gall extract does not support this structure as only two galloyl residues are clearly attached to the sugar residues, as in structure (IX). Whatever the mode of linkage to each other of the repeating units then, the peak at 510 Da is close enough to be the same as in turkey gall tannin, namely, a glucose to which are linked two gallic acid residues ($23(\text{Na}^+) + 180 + 152 + 152 = 507$ Da). The series that starts with the 510 Da (digalloyl glucose) continues with the 996 Da (digalloyl glucose dimer) and 1483 Da (digalloyl glucose trimer) oligomers. The other 162-Da repeating peaks belong to similar molecules in which alternatively a galloyl or two galloyl residues have been lost together with some part of the sugar residue. However, a better interpretation of this spectrum can be the same given for the two galloellagic tannins (chestnut and oak tannins).

Thus, in Figure 9, the 162-Da repeating unit can be interpreted as a glucose in which a single —OH has been lost. This indicates that in commercial chinese gall tannin a single monogalloyl, or digalloyl or trigalloyl residue, may be linked to each glucose of the main sugar skeletal chain, as already reported by earlier authors.⁹ Thus, starting from the 510-Da peak (digalloyl glucose), the series that follows is formed by the 672-, 834-, 996-, 1159-Da peaks. This is, hence, a series of oligomers of up to glucose hexamers on which two galloyl residues are still linked onto a single sugar residue of the chain. To this series is superimposed the 510-Da (digalloylglucose), 996-Da (digalloyl glucose dimer), and 1483-Da (digalloyl glucose trimer) series. The 965-Da peak is likely to be a pentagalloyl glucose, although this is not at all dominant in this spectrum. This implies that monogalloyl, digalloyl, and trigalloyl groups were initially linked to this tannin. This is supported by the earliest previous work⁹ on this tannin. Previous authors have shown that in chinese gall tannin and in sumach tannin the products isolated were essentially octa- and nonagalloylated glucose.⁷ They estimated that the gallotannin contained a pentagalloylglucose nucleus to which some three or four additional galloyl groups were attached. The MALDI-TOF analysis presented here shows this not to be the case, or at least not the only case, and brings to the fore the skeletal polymeric nature of the carbohydrates of the galloyl glucose chains.

CONCLUSION

The structure of six commercial hydrolyzable tannins has been examined by MALDI-TOF MS. Their oligomeric structures and structure distribution have been defined and have in some cases been found to be similar to results reported by other authors for tannin extracted for analysis. However, in the commercially extracted tannins some marked differences from what already reported were noted. Degradation products of rather different structure than what was reported were present. Relevant pentagalloyl, trigalloyl, and digalloyl glucose monomers were observed in MALDI-TOF spectra of the galloellagic chestnut and oak tannin extracts and in one gallotannin, chinese gall tannin extract. In the positive ion mode spectra the most remarkable findings were that most of the galloyl residues of the galloyl glucose chains were stripped from the skeletal glucose chain carrying them. This allowed the observation of oligomers, in some cases up to 16 or 17 glucose units long, totally or almost totally stripped of galloyl residues, as their molecular weight came within the range of molecular masses

more easily observed with MALDI MS. The stripped galloyl residues were found in the negative ion mode spectra, these residues being still present in the commercial extract. This indicated that a wide distribution up to very long galloylglucose chains exist in most commercial hydrolyzable tannin extracts. It also indicated that all these commercial tannin extracts are mainly composed of long pentagalloyl glucose chains in which some galloyl residues have been detached, giving the appearance of mixed di-, tri-, and pentagalloyl glucose repeating units being present in the same chain. This supported also the concept advanced previously by other evidence that such tannins may be present in the wood as an extended macromolecular chains network.

The pentagalloyl glucose units in tannin chains are considered to be linked through a galloyl residue of a unit to a galloyl residue of the unit that follows it and of the unit that precedes. However, the presence of long glucose chains in the positive ion mode MALDI-TOF spectra in the cases in which most or all of the galloyl residues have been stripped indicates that the manner in which the pentagalloyl glucose repeating unit is linked may be sugar residue to sugar residue. This is rather different from the normally accepted form of linkage of these tannins.

Commercial tara and turkey gall tannins have been shown to be mainly polygallic oligomers of up to eight gallic acid residues linked to each other in a chain. Commercial sumach extract revealed itself a more complex mixture of glucose oligomers up to 13 repeating units where to several but not all of the sugar repeating units is linked a galloyl or digalloyl residue.

References

1. Fengel, D.; Wegener, G. *Wood, Chemistry, Ultrastructure, Reactions*; Walther DeGruyter: Berlin, 1984.
2. Tang, H. R.; Hancock, R. A.; Covington, A. D. In *Proceedings of the XXI IULTCS (International Union of Leather Trade Technologists and Chemists)*: Barcelona, Spain, 1991; p 1503.
3. Haslam, E. *The Chemistry of Vegetable Tannins*; Academic Press: London, 1966.
4. Roux, D. G. In *Plant Polyphenols 1*; Hemingway, R. W.; Laks, P. E., Eds.; Plenum: New York, 1992; pp 7–39.
5. Pasch, H.; Pizzi, A. *J Appl Polym Sci* 2002, 85, 429.
6. Garro-Galvez, J. M.; Riedl, B.; Conner, A. H. *Holzforchung* 1997, 51, 235.
7. Armitage, R.; Bayliss, G. S.; Gramshaw, J. W.; Haslam, E.; Haworth, R. D.; Jones, K.; Rogers, H. J.; Searle, T. *J Chem Soc* 1961, 1842.
8. Horler, H.; Nursten, H. E. *J Chem Soc* 1961, 3786.
9. Buziashvili, Sh.; Komissarenko, N. F.; Kovalev, I. P.; Gordienko, V. G.; Kolesnikov, D. G. *Khimiya Prirodnykh Soedinenii* 1973, 6, 789.

10. Karas, M.; Bachmann, D.; Bahr, U.; Hillenkamp, F. *Int J Mass Spectrom Ion Phys* 1987, 78, 53.
11. Bahr, U.; Deppe, A.; Karas, M.; Hillenkamp, F.; Giessmann, U. *Anal Chem* 1992, 64, 2866.
12. Danis, P. O.; Karr, D. E.; Mayer, F.; Holle, A.; Watson, C. H. *Org Mass Spectrom* 1992, 27, 843.
13. Danis, P. O.; Karr, D. E. *Org Mass Spectrom* 1993, 28, 923.
14. Ehring, H.; Karas, M.; Hillenkamp, F. *Org Mass Spectrom* 1992, 27, 472.
15. Pasch, H.; Resch, M. *Polym Anal MALDI-MS GIT Fachz Lab* 1996, 40, 90.
16. Pasch, H.; Gores, F. *Polymer* 1995, 36, 1999.
17. Pasch, H.; Pizzi, A.; Rode, K. *Polymer* 2001, 42, 7531.
18. Yoshida, T.; Hatano, T.; Ito, H.; Okuda, T. In *Plant Polyphenols*; Gross, G. G.; Hemingway, R. W.; Yoshida, T., Eds.; Plenum: New York, 1999; Vol. 2, pp 127–144.
19. Amakura, Y.; Yoshida, T. *Chem Pharm Bull* 1996, 44, 1293.

MALDI-TOF-CID pour l'élucidation de la microstructure des tanins hydrolysables polymères.

Auteurs: N.RADEBE, K.RODE, A.PIZZI, S.GIOVANDO, H.PASCH

J. Appl. Polym. Sci. 128: 97–107, 2013, DOI: 10.1002/APP.38156

Dans cette étude, nous avons évalué de la manière la plus approfondie possible, la structure moléculaire de tanins hydrolysables grâce à la nouvelle technique analytique du MALDI-TOF-CID.

Les tanins végétaux de haut poids moléculaire sont des mélanges complexes de composés dont la distribution en masse moléculaire et en composition chimique est large. Les tanins hydrolysables de tara, de galle turque et de châtaignier ont déjà été analysés et comparés en utilisant la spectrométrie de masse MALDI-TOF. Bien que la MALDI-TOF MS révèle la structure des oligomères des tanins, cette méthode ne permet pas de différencier des isomères avec des masses isobares et, par conséquent, des interprétations structurales ambiguës peuvent être faites dans un certain nombre de cas. Afin de déterminer les microstructures réelles, des analyses ont été menées par MALDI-TOF-CID (dissociation induite par collision). La MALDI-TOF-CID permet la détermination des séquences de monomères et la répartition des structures isobares peut être faite.

La spectrométrie MALDI-TOF-CID s'est ainsi avérée très utile pour la détermination de la séquence des monomères et des structures d'oligomères dans les mélanges de tanins hydrolysables et la microstructure réelle a pu être clairement identifiée par cette technique.

Pour les trois tanins hydrolysables représentatifs étudiés (tara, châtaignier et galle turque), il a été montré que ceux de la galle turque et de tara présentent un certain nombre de similitudes dans leurs spectres MALDI-TOF. La MALDI-TOF-CID, cependant, indique que les tanins de tara contiennent de l'acide ellagique tandis que ceux de galle turque présentent des arrangements d'unités d'acide gallique autour d'un noyau de glucose. Le tanin de châtaignier quant à lui est composé principalement de glucose digalloyle, de glucose et d'unités d'acide gallique.

N.RADEBE, K.RODE, A.PIZZI, S.GIOVANDO, H.PASCH, MALDI-TOF-CID for the Microstructure Elucidation of Polymeric Hydrolysable Tanins, *J.Appl.Polym.Sci.* 2013, DOI: 10.1002/APP.38156

MALDI-TOF-CID for the Microstructure Elucidation of Polymeric Hydrolysable Tannins

Nonhlanhla Radebe,¹ Karsten Rode,² Antonio Pizzi,³ Samuele Giovando,⁴ Harald Pasch¹

¹Department of Chemistry and Polymer Science, University of Stellenbosch, Stellenbosch 7602, South Africa

²Deutsches Kunststoff-Institut, Schlossgartenstr. 6, 64289 Darmstadt, Germany

³ENSTIB-LERMAB, University of Lorraine, 27 Rue Philippe Seguin, 88051 Epinal Cedex, France

⁴Centro Ricerche per la Chimica Fine Srl, Silva Chimica, Via Torre, S.Michele Mondovì, Italy

Correspondence to: H. Pasch (E-mail: hpasch@sun.ac.za)

ABSTRACT: High molar mass wood tannin extracts are complex mixtures that are distributed in both molar mass and chemical composition. Hydrolysable tannins from tara, Turkey gall, and chestnut woods were analyzed and compared using matrix-assisted laser desorption/ionization time-of-flight (MALDI-TOF) mass spectrometry. Although MALDI-TOF MS reveals the oligomer structure of the tannins, this method cannot distinguish between isomers with isobaric masses and, therefore, ambiguous structural assignments were made in a number of cases. To determine the actual microstructures present, MALDI-TOF-CID (collision induced dissociation) experiments were conducted. MALDI-TOF-CID enables monomer sequence determination and positive assignments of isobaric structures can be made. © 2012 Wiley Periodicals, Inc. *J. Appl. Polym. Sci.* 128: 97–107, 2013

KEYWORDS: MALDI-TOF; collision induced dissociation; tannins; hydrolysable tannins

Received 15 March 2012; accepted 20 May 2012; published online 25 June 2012

DOI: 10.1002/app.38156

INTRODUCTION

Tannins are divided into two major groups, namely, condensed and hydrolysable tannins. Condensed tannins (also known as polyflavonoids or proanthocyanidins) are based on flavonoid units that undergo condensation and polymerization reactions to form oligomers with varying degrees of polymerization.¹ Hydrolysable tannins differ from condensed tannins as they are derivatives of gallic acid and are usually esterified to a carbohydrate core, mainly glucose.^{1–4} However, these tannins often occur as complex mixtures of simple phenols (e.g., pyrogallol), gallic and digallic acids as well as esters of sugars and other structures (e.g., three-dimensional networks) formed as a result of oxidative coupling and further esterification of the galloyl groups. The simplest of the hydrolysable tannins are gallotannins that are made up of polygalloyl esters of glucose such as pentagalloyl glucose (PGG).^{4,5}

These tannins are found in various plants and trees such as chestnut, tara, Chinese gall, turkey gall, sumac, and oak tannin. Monomers that form gallotannins are pentagalloylglucopyranose and the precursor for ellagitannins is trigalloyl-HHDP-glucopyranose.^{5–9} The different types of hydrolysable tannins structures are shown in Figure 1. In nature, however, there exist different oxidation products and polymerized forms of the molecules

described. In the analysis of tannin extracts, other higher oxidation structures were isolated, such as castalin/vescalin and vescalagin/castalagin, and the structures are shown in Figure 2.⁶

In the analysis of both condensed and hydrolysable tannins, matrix-assisted laser desorption/ionization time-of-flight (MALDI-TOF) was used very successfully to determine the chemical composition of complex plant extracts.^{10–15} The analysis of tannins using MALDI-TOF is a relatively new technique and provides additional information on the structure and molar mass distributions in a single experiment. Pasch and coworkers¹³ applied MALDI-TOF to analyze polymeric tannins. In the analysis of a chestnut extract which is a hydrolysable tannin, the presence of vescalin/castalin and vescalagin/castalagin was conclusively determined.^{12,15} MALDI-TOF has been successfully applied offline to analyze fractions obtained from a chromatographic separation, information obtained from this technique is very valuable as it can reach very high molar masses.^{15–18} Electrospray ionization (ESI)-MS as an alternative method tends to form multiply charged molecules while MALDI-TOF provides mostly singly charged molecules thus making the spectra easier to interpret. One major problem of MALDI-TOF in particular for higher oligomers is that a given mass peak only provides the elemental composition. The sequence of these units in the macromolecule, however, cannot be obtained by MALDI-TOF.

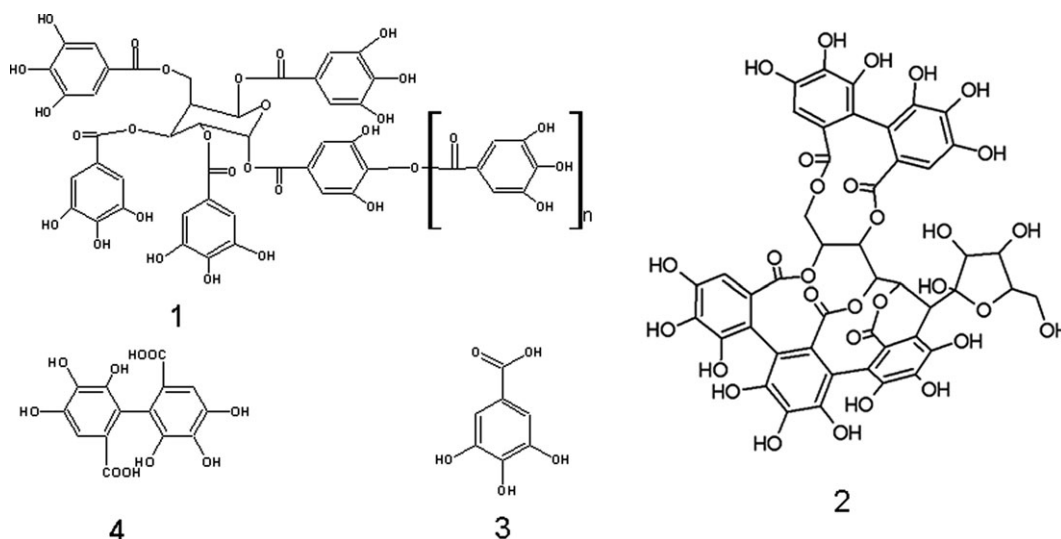

Figure 1. Typical structures of hydrolysable tannins: gallotannin (1), ellagitanin (2), gallic acid (3), hexahydroxydiphenic acid (HHDP) (4).

A new promising technique for the analysis of tannin monomer sequences is post source decay (PSD) fragmentation whereby a specific ion is selected from a MALDI-TOF spectrum and is subjected to higher laser intensities that result in fragmentation of the “mother” ion and the detection of the resulting fragments.^{16,19} When the ions fragment in the field free region, the process is termed PSD.^{16,20} Behrens et al.¹⁶ was the first to show the applicability of this method to tannins and condensed tannins from lime and spruce. Another method that performs a similar type of analysis is collision induced dissociation (CID) whereby the precursor ion is selected from the first TOF analyzer and introduced into a collision cell whereby it collides with inert gas molecules. The fragments formed are then reflected and analyzed in the second TOF analyzer.^{20,21} Although this technique has not been used for the analysis of tannins it has been shown to be applicable to biopolymers as well as synthetic polymers and thus shows great promise for analysis of tannins.^{20,21} Recently, ion trap mass spectrometry has been used for the analysis of tannins. Corke and coworkers^{22,23} identified phenolic antioxidants in Chinese roses

and galls while Zhang and Lin analyzed condensed tannins in Pacific oak leaves.¹⁰

In a first publication, we reported on the analysis of condensed tannins by MALDI-CID.²⁴ The aim of this study is to elucidate the microstructure of hydrolysable tannins that were obtained from various wood extracts. It is known that hydrolysable tannins from different origins have different chemical compositions. Chestnut tannins are known to contain digalloylglucose while tara tannins contain ellagic acid. To elucidate their complex composition in detail, three samples were selected for this study, namely a chestnut tannin, a tara tannin, and a Turkey gall tannin. It shall be demonstrated that MALDI-TOF-CID is a unique method to determine the topology of the oligomers and the arrangement of gallic acid moieties around the sugar core.

EXPERIMENTAL

Materials

The description of the samples and the types of tannins involved are provided in Table I.

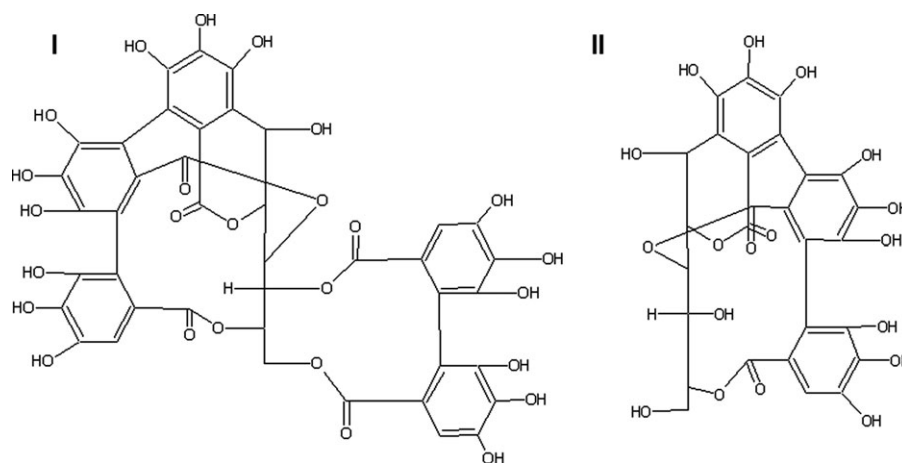

Figure 2. Structures of (I) castalagin/vescalagin and (II) castalin/vescalin positional isomers extracted from chestnut tannin [3].

Table I. Sample List with Description and Tannin Type

Sample	Description	Type of tannin
1	Tara, solvent-extracted	Hydrolysable tannin
2	Turkey Gall, solvent-extracted	Hydrolysable tannin
3	Chestnut, water-extracted	Hydrolysable tannin

Sample Preparation

Chestnut Tannin. The chestnut tannin is an extract of the wood of chestnut tree (*Castanea sativa*) that grows naturally in central Europe. The wood, after being separated from the bark, is chipped into small pieces of 1–4 cm and is charged in an extractor battery where it is extracted with water at 105–115°C. This first raw extract, that contains around 5% of dry material, is concentrated to 10% of dry material with a multiple effect concentrator. At this concentration, the hemicelluloses and gums are flocked and eliminated. After this purification step, the extract is concentrated to 50% of dry material and spray-dried to powder.

Turkey Gall Tannin. The Turkey gall tannin is an extract of Turkey galls that are produced by larvae of Gallic bee insects (*Cynips gallae-tinctoriae*) who are parasitized in young branches of the Fagaceae Gallic tree (*Quercus infectoria*) growing in the oriental Mediterranean coasts. The galls are manually collected, air dried, and stored. Then the galls are milled and extracted several times with organic solvents like acetone, ethanol, ethyl acetate and their mixtures with water to regulate the yield and the purity. In a concentrator, the solvents are stripped with vacuum and with several additions of water. The obtained water-dissolved extract is filtered and purified. In this step sugars, hemicelluloses, gums, natural resins, and chlorophylls are eliminated. The purified tannin solution is concentrated to 50% of dry material and spray-dried to powder.

Tara Tannin. The Tara tannin is an extract of the pods of Peruvian Tara (*Caesalpinia spinosa*). The pods are manually collected from the trees of Tara twice a year, air dried, separated from the seeds, milled, and stored followed by multiple extraction with organic solvents like acetone/water or ethanol/water mixtures. In a concentrator, the solvents are stripped with vacuum and with several additions of water. The obtained water-dissolved extract is filtered and purified. In this step sugars, salts and polysaccharides are eliminated. The purified tannins solution is concentrated to 50% of dry material and spray-dried to powder.

MALDI-TOF and MALDI-TOF-CID Analysis

MALDI-TOF-CID experiments were performed on an Axima-TOF² spectrometer (Shimadzu Biotech, Manchester, UK), equipped with a nitrogen laser (337 nm), an ion gate for the selection of precursor ions and a collision cell. The windows for separation of precursor ions were approximately 4 Da. Argon has been used as the collision gas. The pressure within the collision cell was 8×10^{-6} mbar. The pulsed extraction ion source accelerated the ions to a kinetic energy of 20 keV. All data have been obtained in positive ion linear mode applying the accumulation of 441 scans per spectrum. The calibration of the linear mode as well as the reflectron mode for CID analysis was done using PEG in mass range up to 2000 Da. The accuracy of the

product ion calibration is 0.5 Da. The mass calibration was conducted based on the average masses. Compared to the monoisotopic masses and depending on the accuracy of the calibration, mass differences of 1–2 Da may be observed. This inaccuracy, however, does not disturb the peak assignment. Higher resolution can be obtained by using the reflectron mode.

The samples were dissolved in acetone/water 50/50 (% v/v) at a concentration of 4 mg/mL. The sample solutions were mixed with a 10 mg/mL solution of the matrix in the same solvent. 2,5-dihydroxy benzoic acid was used as the matrix. NaCl was added as the salt to enhance ion formation. The sample and matrix were then combined at a ratio of 1 : 1. 5 µL of the resulting solution was spotted on a 384 well MALDI-TOF plate, followed by evaporation of the solvent at ambient temperature without any assistance. The MALDI-TOF target was then analyzed to give the resulting spectra. In all cases, for the MALDI as well as for the MALDI-CID experiments, a very good reproducibility of the spectra was obtained both regarding the ion peaks and their positions.

RESULTS AND DISCUSSION

The hydrolysable tannins were analyzed by MALDI-TOF MS and as illustrated before this technique is successful in determining both the molar mass and the chemical composition. MALDI-CID was subsequently used to elucidate the molecular topology and the arrangement of the different gallic acid units in the oligomers. The tara and turkey gall tannins are both gallo-tannins in the polygallic form, see Figure 3.⁶

MALDI-TOF of Tara and Turkey Gall Tannins

Figure 4(a, b) show the MALDI-TOF spectra of the hydrolysable tannins from tara and turkey gall, respectively. As expected, similar repeat units of 152 Da are observed for both tannins confirming the general structure as shown in Figure 3. The structural assignments were done based on the work of Pizzi et al.⁶

The peaks at m/z of 521, 673, 825, 978, 1130, 1282, and 1435 in the tara tannin represent the major series with the mass increments of 152 Da belonging to gallic acid units. As has been shown previously, tara tannin is based on an ellagic unit that is decorated with different numbers of gallic acid units. In addition, the ellagic acid contains an ester group (—COO—) which contributes an additional mass of 44 Da to the oligomer mass. The ester group stems from hydrolysis reactions that take place

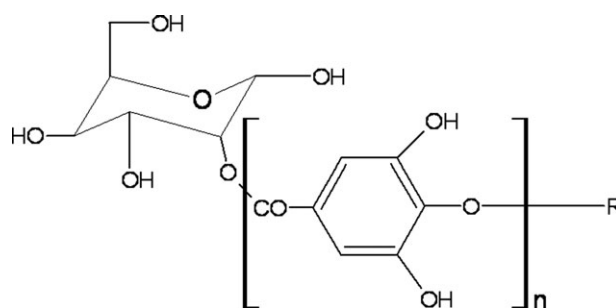

Figure 3. Proposed structure of gallo-tannins extracted from tara and turkey gall.

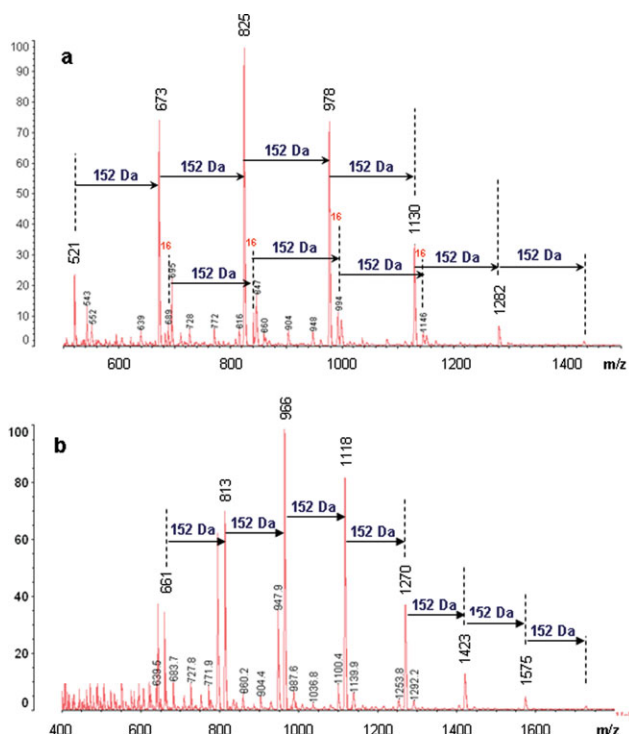

Figure 4. MALDI-TOF spectra of solvent-extracted tara (a) and turkey gall (b) tannins with repeat units of 152 Da as indicated. [Color figure can be viewed in the online issue, which is available at wileyonlinelibrary.com.]

during the extraction process. Thus, the following equation was used to construct Table II: $M + Na^+ = 23 (Na^+) + 304 - 1H$ (ellagic unit) + 152 (gallic unit) + 44 (COO). According to Figure 4, oligomers are detected up to heptamers. The first oligomer peak is detected at 521 Da. This peak corresponds to the sodium adduct of an ellagic acid with one gallic acid unit attached. All subsequent peaks are formed due to the addition of further gallic acid units.

A series of peaks with lower intensity appears adjacent to the major series also having repeat units of 152 Da. However, this minor series is shifted by 16 Da from the major series and thus is made up of different but related structures. These peaks correspond to the major oligomer series plus an OH-group.

Table II. Dominant Oligomer MALDI-TOF Peaks and Description of Structures Present in the Solvent-Extracted Tara Tannin

Calculated $M + Na^+$	Experimental $M + Na^+$	Description $M + Na^+$
522	521	Ellagic acid + COO + 1 gallic acid
674	673	Ellagic acid + COO + 2 gallic acid
826	825	Ellagic acid + COO + 3 gallic acid
978	978	Ellagic acid + COO + 4 gallic acid
1130	1130	Ellagic acid + COO + 5 gallic acid
1282	1282	Ellagic acid + COO + 6 gallic acid
1434	1435	Ellagic acid + COO + 7 gallic acid

Table III. Dominant Oligomer MALDI-TOF Peaks and Description of Structures Present in the Solvent-Extracted Turkey Gall Tannin

Calculated $M + Na^+$	Experimental $M + Na^+$	Description $M + Na^+$
659	661	Glucose + 3 gallic acid
811	813	Glucose + 4 gallic acid
963	966	Glucose + 5 gallic acid
1115	1118	Glucose + 6 gallic acid
1267	1270	Glucose + 7 gallic acid
1419	1422	Glucose + 8 gallic acid
1571	1575	Glucose + 9 gallic acid

A look at the turkey gall tannin also shows a simple polygallic structure. The basic structure of the turkey gall is quite similar to that of the tara tannin but does not include any ellagic acid groups in its basic structure. The first member of the main series of peaks is observed at m/z 661 representing the sodium adduct of three gallic acid units attached to glucose, see Figure 4(b). It is calculated using the following equation: $M + Na^+ = 23 (Na^+) + 180$ (glucose) + 3×152 (gallic unit). The dominant oligomer peak at 965.9 Da is believed to represent PGG followed by oligomers that contain even more gallic acid units. A tentative peak assignment is presented in Table III.

MALDI-TOF-CID of Tara and Turkey Gall Tannins

As has been demonstrated, MALDI-TOF reveals the oligomer composition and the presence of different chemical moieties and building blocks. However, the arrangement of the different molecular fragments in a given molecule cannot be provided. As has been shown previously, only CID experiments can provide detailed information on the topology of the different oligomers. In the present case, the interesting question is how the gallic acid units are arranged around the core fragment which is an ellagic acid for tara and a glucose for Turkey gall.

For further investigation of the oligomer structures presented in the tara tannin, the precursor ions with m/z 824.5 and 839.8 were selected for fragmentation experiments. The first to be considered will be the trimer with m/z 824.5. The MALDI-CID

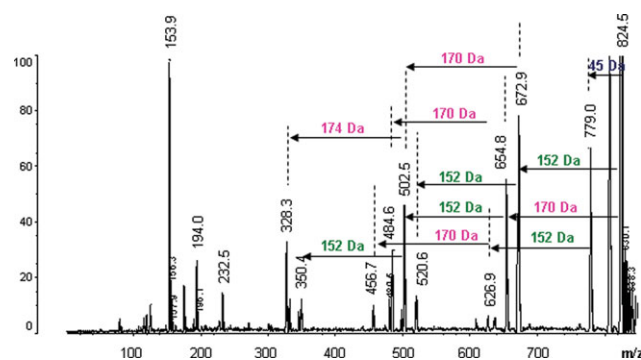

Figure 5. MALDI-TOF-CID spectrum of the trimer ion at m/z 824.5 from tara tannin, the fragmentation pattern is illustrated by indicating the mass loss incurred from the precursor ion. [Color figure can be viewed in the online issue, which is available at wileyonlinelibrary.com.]

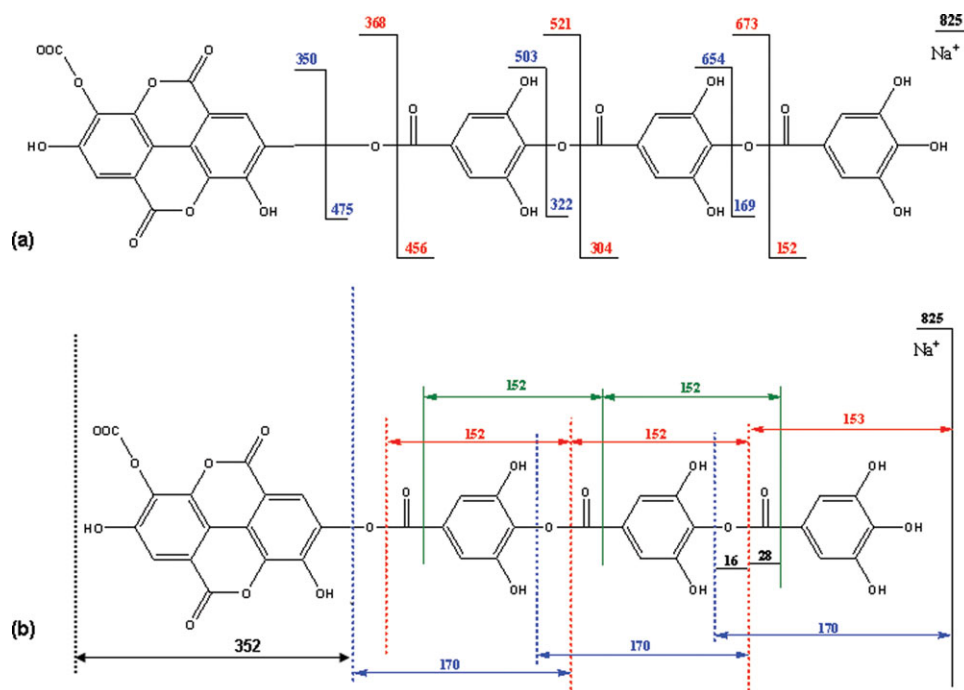

Figure 6. Proposed structures and fragmentation patterns for the parent ion at m/z 824.5 observed in the MALDI-TOF spectrum of the tara tannin, (a) observed fragment masses, (b) structures that form the observed mass increments (repeat units). [Color figure can be viewed in the online issue, which is available at wileyonlinelibrary.com.]

spectrum for this oligomer is presented in Figure 5; the mass loss incurred by the precursor ion and the product ions are also indicated. The fragmentation pattern of the oligomer is relatively simple and the dominant ions appear at m/z 673, 502, 328, and 154. These peaks belong to different oligomer series, for example, m/z 824-673-520, 655-502-350, and so forth showing losses of 152 Da (gallic acid) or 170 Da (gallic acid + $-\text{O}-$). The peak at 328 Da is obtained from the oligomer at m/z 502 by the loss of one gallic acid unit and an oxygen. The loss of units of 152 Da occurs three times, representing the loss of 3 gallic acid units that form the oligomer structure. Once formed, the fragment ions may lose $-\text{O}-$ or $\text{C}=\text{O}$ groups, shown by mass losses of 16 and 28 Da, respectively. These types of fragments show that the galloyl ester bond is the most labile, and thus the fragmentation may occur before or after the carbonyl group of the ester bond. However, as observed in the spectrum, there are no fragment ions resulting from the simultaneous loss of the $-\text{O}-$ and $\text{C}=\text{O}$ groups.

The loss of the 3 gallic acid units results in the formation of the fragment ion at m/z 350 which can be assigned to a proton adduct of ellagic acid that still contains the ester group. The fragment at m/z 301 can then be assigned to the proton adduct of a single ellagic acid unit. The proposed structure with an ellagic acid unit at the terminal end of the molecule is supported by the present fragmentation pattern.

The precursor ion (m/z 824) additionally loses a mass of 44 Da arising from the ester group to form the ion m/z 779 which then undergoes further fragmentation by losing gallic acid units. This confirms the presence of the postulated 44 Da mass, and the presence of the m/z 350 ion indicates that this group is attached

to ellagic acid unit as there are no fragments observed that indicate its attachment to the gallic acid units. As the exact position at the ellagic acid cannot be determined, an arbitrary position was selected for the location of the ester group (Figure 6).

A summary of some typical fragmentation products is given in Table IV.

Further investigations were conducted on the parent ion at m/z 839.8 which appears in the MALDI-TOF spectrum only as minor peak. This oligomer is related to the previously determined m/z 824 structure by an additional mass of 16 Da. This ion peak was tentatively assigned to the sodium adduct of a tri-galloyl diglucose trimer, see Figure 7. This form of structure may be present due to the polygallic form of the oligomers present in the tara tannin extract. As can be seen, the MALDI-CID spectra of the two ions show some similarities in the higher mass region but distinct differences in the lower mass region indicating that the two ions have different molecular structures of the core, compare Figures 5 and 8.

The MALDI-CID spectrum of the ion at m/z 839 in Figure 8 shows mass losses of 152 and 170 Da which indicate losses of gallic acid units in a rather simple fragmentation pattern. The loss of two gallic acid units can be observed although it was postulated that the ion contains three gallic acid units as is shown in Figure 7. A possible interpretation is that gallic acid units do not form a trimer that is attached to one glucose side but rather a dimer and a monomer that are attached to different glucose sites. Assuming that all ester bonds of the gallic acid units have the same stability, this interpretation would fit the observed fragmentation pattern.

Table IV. Structures of Selected Fragment Ions Observed in the MALDI-CID Spectrum of the Parent Ion at m/z 824 from Tara Tannin

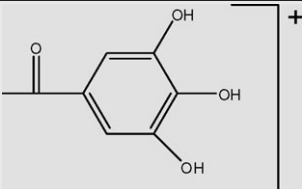
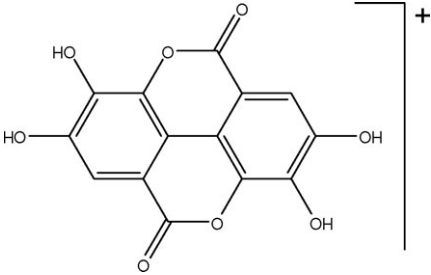
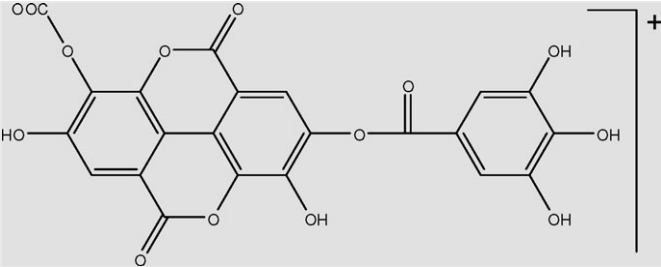
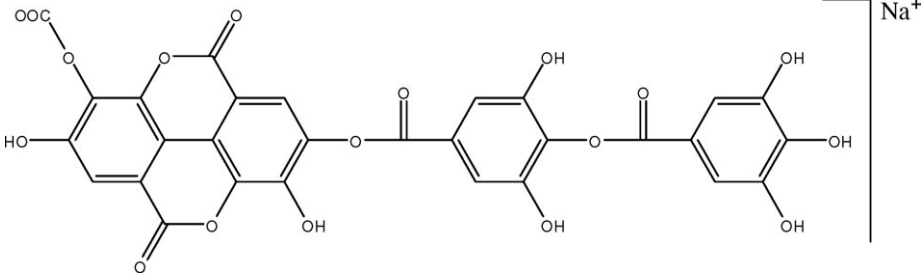
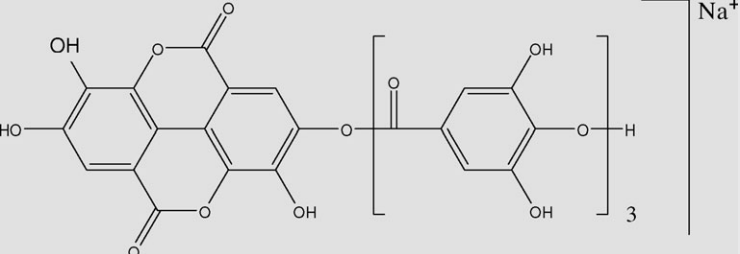
m/z (observed)	m/z (calc.)	Fragment ion
154	153	
301	302	
502	499	
673	672	
779	778	

A more complex fragmentation pattern is obtained in the mass range <300 Da. The observed fragment peaks are assumed to be a result of the fragmentation of the core molecule in the present case the diglucose. Fragmentation may occur via inter-

nal fragmentations of the glycosidic linkage, the presence of these internal fragments may be indicated by a mass loss of 134 Da. These types of fragmentations are commonly observed during MALDI-CID of carbohydrates.²⁵ The internal fragments

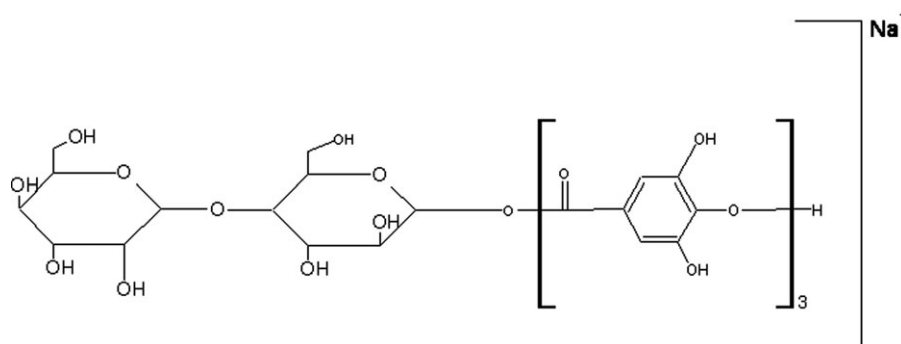

Figure 7. Proposed structure for the trimer at m/z 839 as postulated from the bulk sample MALDI-TOF analysis.

result from cleavage of the glucose ring at bonds adjacent to the cyclic ether group. The gallic acid units may be located at any of the OH groups present in the glucose structure; however, due to the presence of the internal fragments from the glucose molecules, exact locations of these groups may be determined. In the present case, one of the gallic acid units must be located at the terminus of the glucose unit; this is shown by the presence of a mass loss of 288 Da observed in the spectrum. This mass can only be formed by the loss of a gallic acid unit attached to a 134 Da fragment from the glucose monomer. This assumption is further confirmed by the loss of a fragment of 272 Da, see Figures 8 and 9.

In the case of the Turkey gall tannin, it was assumed that the gallic acid units are attached to a glucose core. To investigate the structure of the Turkey gall tannin in detail, the parent ion at m/z 811.6 which is assumed to be a tetramer of four gallic acid units attached to glucose was analyzed by CID. The fragmentation spectrum is shown in Figure 10. As can be seen there, the fragmentation pattern is relatively simple and resembles closely the type of fragmentation observed for the m/z 824.5 ion from the tara tannin. In the fragment spectrum of the ion at m/z 811.6 there are no fragments resulting from the glucose monomer. This is due to the fact that only a single glucose monomer is present and thus higher energies would be required to form the 134 Da mass fragment previously shown for glucose oligomers. In addition, the glucose molecule is more stable against fragmentation than the galloyl esters and, therefore, fragmentation preferentially occurs at these positions.

The fragmentation of the oligomer at m/z 811.6 takes place as a sequential loss of two gallic acid units to form the fragment at m/z 469.1 which is obviously the glucose monomer with two gallic acid units attached. The structure forming the m/z 811.6 ion can thus be assigned as a branched structure with two gallic acid dimers linked to different positions at the glucose monomer, see Figure 10.

As a second parent molecule, the ion at m/z 964.2 was investigated by MALDI-TOF-CID, see Figure 11. This molecular ion was tentatively assigned to PGG. The CID spectrum shows sequential losses of fragments of 152/170 Da corresponding to gallic acid units. Comparing Figure 5 with Figure 11 it is obvious that the arrangement of the gallic acid units must be different. While in Figure 5 the consecutive loss of at least three units can clearly be seen, in Figure 11 the loss of only two gallic acid units can be identified. This is similar to the behavior of the parent ion at m/z 811.6. Therefore, it is assumed that the gallic acid units are not arranged as a trimers or tetramers attached to one position of the core molecule but rather as monomers or dimers attached to different positions of the core molecule. The fragment peak at m/z 642 would most likely

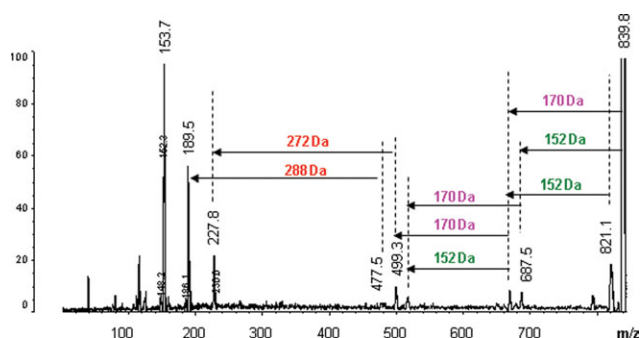

Figure 8. MALDI-TOF-CID spectrum of the parent ion at m/z 839.8 of the tara tannin. [Color figure can be viewed in the online issue, which is available at wileyonlinelibrary.com.]

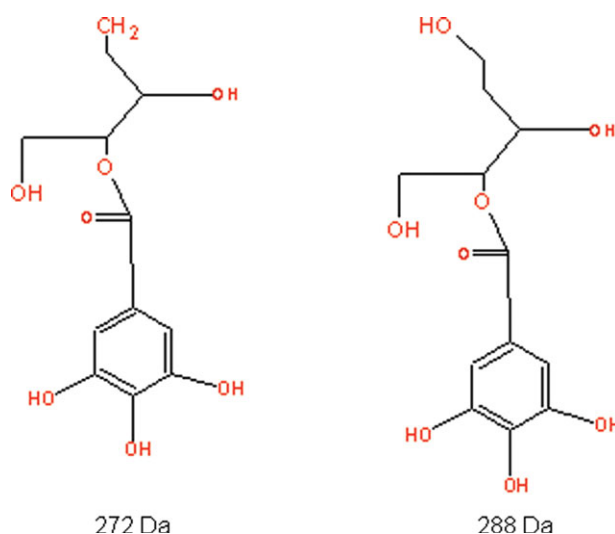

Figure 9. Fragments observed in the MALDI-TOF-CID spectrum of the tara tannin trimer m/z 839.8. [Color figure can be viewed in the online issue, which is available at wileyonlinelibrary.com.]

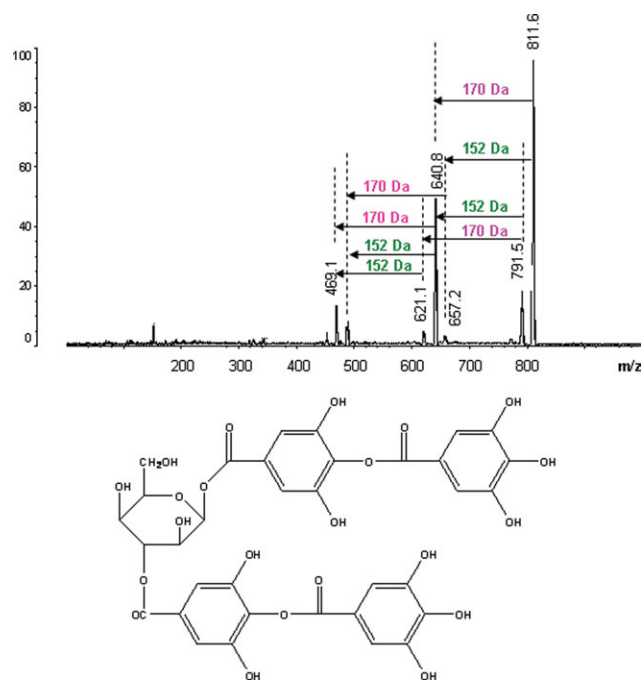

Figure 10. MALDI-TOF-CID spectrum of the parent ion at m/z 811.6 from solvent-extracted Turkey gall tannin and proposed structure of the parent ion. [Color figure can be viewed in the online issue, which is available at wileyonlinelibrary.com.]

correspond to a trigalloylglucose, see Figure 11 for the topology of the parent ion.

Further investigations were performed on a pentamer related to the previous oligomer. As shown for the tara tannin, a small difference in masses between related oligomers can display very different structures. This point is further illustrated by analysis of the parent ion at m/z 947.2, the MALDI-CID spectrum of which is shown in Figure 12. In this case, consecutive losses of four gallic acid units is observed. This is a clear indication that these units must have been arranged in the parent molecule as a tetramer. The topology given in Figure 12 is proposed for this oligomer.

MALDI-TOF of Chestnut Tannin

The structures of natural water-extracted chestnut tannin and the chestnut tannin treated with 3.5% ammonium sulfite for use in leather tanning obtained by MALDI-TOF have been reported before.^{6,11} The analysis of both extracts proved the oligomeric nature of the extract *in situ* in the wood, the tannin was shown to be composed of PGG oligomers with up to 16 units.^{6,11} In the water-extracted chestnut tannin, the PGG oligomers were detected up to trimers whereas in the sulfited sample, glucose oligomers stripped of its galloyl units were detected.⁶ The linear mode spectrum of a water-extracted chestnut tannin is shown in Figure 13 being markedly different from the previously reported spectra for this tannin. The peak assignments were made based on Pizzi et al.^{6,11} The mode of extraction clearly affects the composition of this tannin. The repeat unit in this case is 162 Da which cannot be explained by the theories previously presented for the structures present in this

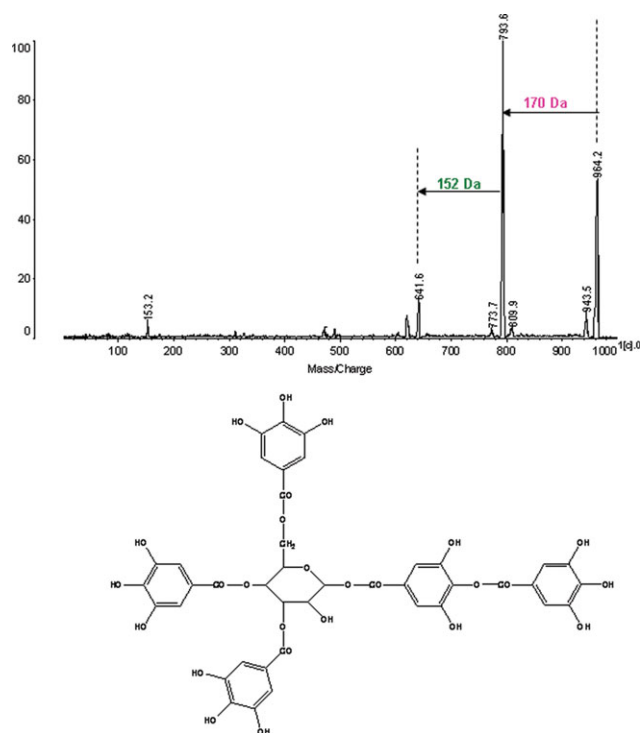

Figure 11. MALDI-TOF-CID spectrum of parent ion at m/z 964.2 from solvent-extracted Turkey gall tannin and proposed structure of the parent ion. [Color figure can be viewed in the online issue, which is available at wileyonlinelibrary.com.]

extract, thus this warrants an in-depth discussion. The repeat unit of 162 Da is similar to the one observed for Chinese gall tannin. The explanation for this distribution was given as oligomers formed by esters of gallic and digallic units attached to glucose.⁶ However, it cannot be determined whether two gallic acid units are attached to each other or independently on

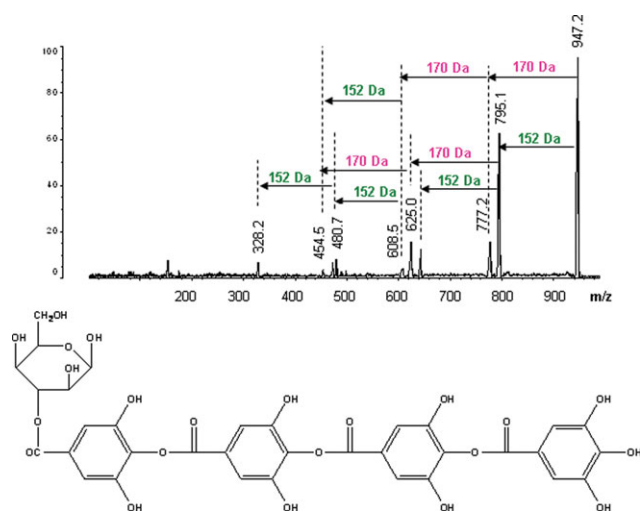

Figure 12. MALDI-TOF CID spectrum of the parent ion at m/z 947.2 representing a pentamer from solvent-extracted turkey gall tannin and proposed parent ion structure. [Color figure can be viewed in the online issue, which is available at wileyonlinelibrary.com.]

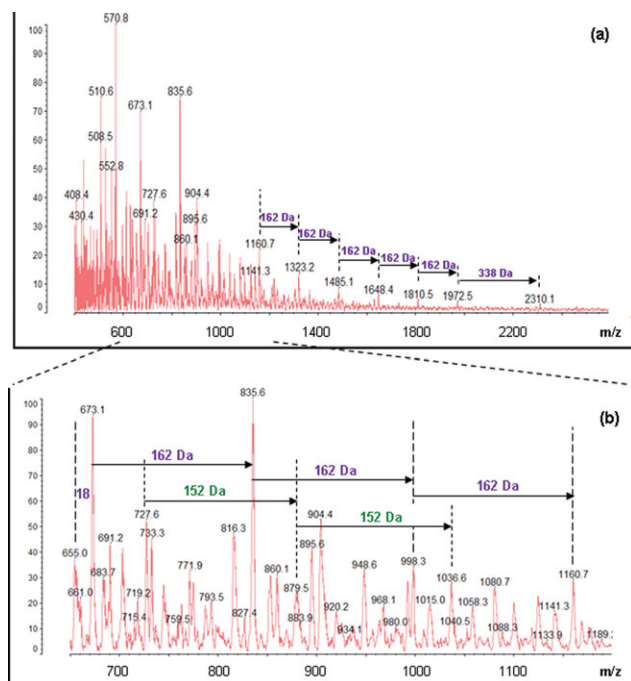

Figure 13. MALDI-TOF spectrum of water-extracted chestnut tannin (linear mode). Mass range: (a) 400–2600 Da (b) 650–1200 Da. The peak assignments are indicated and the details shown in Table V. [Color figure can be viewed in the online issue, which is available at wileyonlinelibrary.com.]

the pyranose ring of the glucose. In addition, ellagic acid units may be present. The proposed structure of the oligomer is shown in Figure 14.

The most abundant oligomer distribution is observed with the series of peaks beginning at 508 Da. This peak is known to be a digalloylglucose monomer (digalloylglucose = $23 (\text{Na}^+) + 152 \times 2 + 180 = 507 \text{ Da}$), the series with 162 Da is completed at 1972 Da. The 162 Da increment represents an additional glucose unit being added to the oligomer structure. A list of peaks and assignments is shown in Table V. As can be seen there are a number of units that are indicated as “stripped glucose.” These

units are glucose units that lost some of the original OH groups together with a loss of gallic acid units. Such reactions may take place during the extraction process as has been discussed previously. The mass of these units is 132 Da.

In the present sample, a dominant series is composed of glucose units that are attached to two galloyl units. These may also be present as an ellagic acid unit. The MALDI experiment alone cannot give a conclusive answer here. The distributions that are seen in the spectrum indicate that the main composition here is long chains of glucose units (up to 9 units) with the terminal group being a digalloyl glucose unit. The peak observed at 438 Da can be assigned to a single galloyl unit attached to two stripped glucose units. This forms another distribution of peaks at m/z 438, 727, 879, and 1036, which have a mass increment of 152 Da indicating galloyl units. The difference of 388 Da observed between the peaks at m/z 1972 and 2310 indicates the presence of an ellagic acid unit attached to a OCO group added to the oligomer chain, ($2310 \text{ Da} = 23 (\text{Na}^+) + 2 \times 152 + 180 + 162 \times 9 + 302 + 44$). This assignment may also be made according to Pizzi et al.⁶ as 2 additional galloyl units being added to the stripped glucose skeleton structure. The former is less likely, however, it is possible that these structures may be present as the chestnut tannin is a known ellagitannin.⁶

MALDI-TOF-CID of Chestnut Tannin

The chestnut tannin is composed of glucose units, gallic acids, and possible ellagic acids. The main constituents in this tannin are galloyl unit oligomers stripped from their glucose core. The applicability of the MALDI-CID has shown to be able to distinguish between the various oligomer structures and thus it will be applied here to note the sequence distribution of the oligomers in this extract. The fragmentation spectrum for the oligomer peak at 672.3 Da is shown in Figure 15.

There are only two fragments formed from the oligomer at m/z 672. The fragmentation patterns have been discussed and analyzed for the tara and Turkey gall tannins. However, the present fragment spectrum for the chestnut tannin does not resemble any of the previously discussed spectra. The fragment mass that is lost by the precursor ion is not consistent with gallic acid

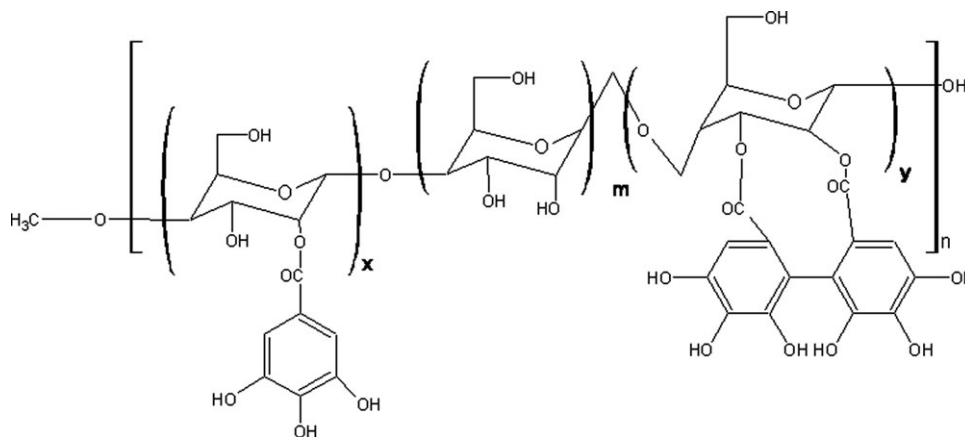

Figure 14. Representation of the possible oligomer structure present in chestnut tannin. With the values of x , m , and y differing according to chemical structure, n represents the total chain length.

Table V. Observed and Calculated Oligomer Peaks from the Linear Mode MALDI-TOF Spectrum of Water-Extracted Chestnut Tannin

Experimental (M + Na ⁺)	Calculated (M + Na ⁺)	Description	Oligomer
508 ^a	507	Digalloyl glucose	Monomer
571 ^a	571	1 Galloyl unit + 3 stripped glucose	Trimer
655 ^a	659	Trigalloyl glucose	Monomer
673 ^a	669	Digalloyl glucose + glucose	Dimer
836 ^a	835	1 Galloyl unit + 5 stripped glucose	Pentamer
968	967	1 Galloyl unit + 6 stripped glucose	Hexamer
998	993	Digalloyl glucose + 3 glucose	Tetramer
1161 ^a	1155	Digalloyl glucose + 4 glucose	Pentamer
1233	1232	1 Galloyl unit + 8 stripped glucose	Octamer
1323 ^a	1317	Digalloyl glucose + 5 glucose	Hexamer
1364	1364	1 Galloyl unit + 9 stripped glucose	Nonamer
1485 ^a	1479	Digalloyl glucose + 6 glucose	Heptamer
1630	1627	1 Galloyl unit + 11 stripped glucose	Undecamer
1648 ^a	1641	Digalloyl glucose + 7 glucose	Octamer
1764	1759	1 Galloyl unit + 12 stripped glucose	Dodecamer
1810 ^a	1803	Digalloyl glucose + 8 glucose	Nonamer
1972 ^a	1965	Digalloyl glucose + 9 glucose	Decamer
2310 ^a	2307	2 Galloyl units + 15 stripped glucose	Pentadecamer

^aDominant oligomer peaks.

units linked via a galloyl ester bond. The most likely structure represented by the fragment at m/z 312 is a diglucose that is completely stripped from gallic or ellagic acid. A proposed fragmentation is shown in Figure 15 being consistent with the

expected structure in Table V and the fragment mass of 312 Da which would be the protonated stripped diglucose. The mass loss of 360 Da corresponds to the mass of the ellagic acid residue plus the sodium cation.

CONCLUSION

MALDI-TOF-CID experiments have been demonstrated to be uniquely powerful for the monomer sequence determination and positive assignments of oligomer structures in wood-based hydrolysable tannin mixtures. Although standard MALDI-TOF MS measurements reveal the oligomer structure of these tannins, this method cannot distinguish between isomers and, therefore, ambiguous structural assignments are obtained in a number of cases. In most cases, the actual microstructures present can unambiguously be identified by MALDI-TOF-CID. In other cases, most likely structures can be proposed.

Three representative hydrolysable tannins were investigated, namely tannins from tara, chestnut, and Turkey gall wood extracts. It has been shown that the tara and Turkey gall tannins show a number of similarities in their MALDI-TOF spectra. MALDI-TOF-CID, however, proved that the tara tannins contain ellagic acid while the Turkey gall tannins exhibit arrangements of gallic acid units around a glucose core. The chestnut tannin has been found to be composed mainly of digalloyl glucose, glucose, and gallic acid units.

REFERENCES

1. Pizzi, A. Wood Adhesives Chemistry and Technology; Marcel Dekker: New York, 1983.

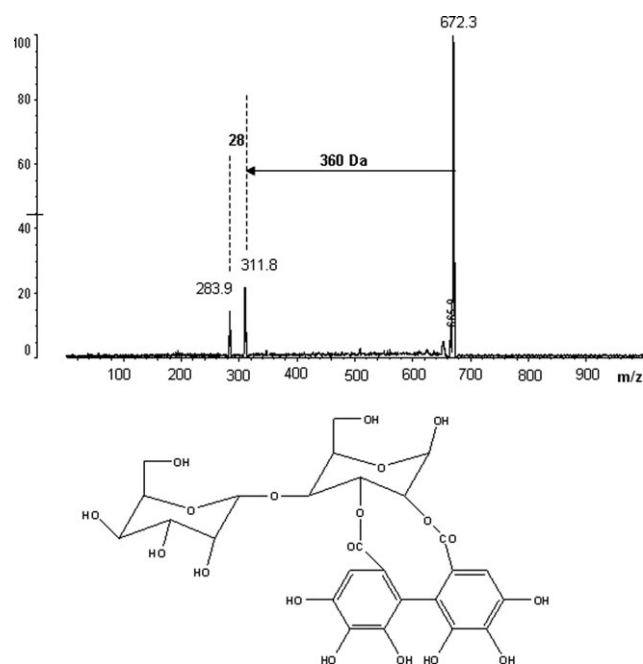

Figure 15. MALDI-TOF-CID spectrum of the parent ion at m/z 672.3 representing a dimer from chestnut tannin and proposed parent ion structure.

2. Pizzi, A. *Advanced Wood Adhesives Technology*; CRC Press: New York, **1994**.
3. White, T. *J. Sci. Food Agric.* **1957**, *8*, 377.
4. Hartzfeld, P. W.; Forkner, R.; Hunter, M. D.; Hagerman, A. E. *J. Agric. Food Chem.* **2002**, *50*, 1785.
5. Haslam, E. *Practical Polyphenolics from Structure to Molecular Recognition and Physiological Action*; Cambridge University Press: New York, **1998**.
6. Pizzi, A.; Pasch, H.; Rode, K.; Giovando, S. *J. Appl. Polym. Sci.* **2009**, *113*, 3847.
7. Pizzi, A. In *Monomers, Polymers and Composites from Renewable Resources*; Belgacem, M., Gandini, A., Eds.; Elsevier, **2008**.
8. Mueller-Harvey, I. *Anim. Nutr. Feed Technol.* **2001**, *91*, 3.
9. Salminen, J.-P.; Ossipov, V.; Loponen, J.; Haukioja, E.; Pihlaja, K. *J. Chromatogr. A* **1999**, *864*, 283.
10. Zhang, L. L.; Lin, Y. M. *Molecules* **2008**, *13*, 2986.
11. Pasch, H.; Pizzi, A. *J. Appl. Polym. Sci.* **2002**, *85*, 429.
12. Pasch, H.; Pizzi, A.; Rode, K.; *Polymer* **2001**, *42*, 7531.
13. Navarette, P.; Pizzi, A.; Pasch, H.; Rode, K.; Delmotte, L. *Ind. Crops Prod.* **2010**, *32*, 105.
14. Oo, C. W.; Pizzi, A.; Pasch, H.; Kassim, M. J. *J. Appl. Polym. Sci.* **2008**, *109*, 963.
15. Perret, C.; Pezet, R.; Tabacchi, R. *Phytochem. Anal.* **2003**, *14*, 202.
16. Behrens, A.; Maie, N.; Knicker, H.; Koegel-Knabner, I. *Phytochemistry* **2003**, *62*, 1159.
17. Raust, J. A.; Bruell, A.; Moire, C.; Farcet, C.; Pasch, H. *J. Chromatogr. A* **2008**, *1203*, 207.
18. Montaudo, G.; Garozzo, D.; Montaudo, M. S.; Puglisi, C.; Samperi, F. *Macromolecules* **1995**, *28*, 7983.
19. Hanton, S. D. *Chem. Rev.* **2001**, *101*, 527.
20. Belgacem, O.; Bowdler, A.; Brookhouse, I.; Brancia, F. L.; Raptakis, E. *Rapid Commun. Mass Spectrom.* **2006**, *20*, 1653.
21. Jackson, A. I. T.; Jennings, K. R.; Scrivens, J. H. *J. Am. Soc. Mass Spectrom.* **1997**, *8*, 76.
22. Cai, Y. Z.; Xing, J.; Sun, M.; Zhan, Z. Q.; Corke, H. *J. Agric. Food Chem.* **2005**, *53*, 9940.
23. Zhu, F.; Cai, Y. Z.; Xing, J.; Ke, J.; Zhan, Z.; Corke, H. *Rapid Commun. Mass Spectrom.* **2009**, *23*, 1678.
24. Radebe, N.; Rode, K.; Pizzi, A.; Pasch, H. *J. Appl. Polym. Sci.* **2012**; to appear.
25. Spina, E.; Sturiale, L.; Romeo, D.; Impallomeni, G.; Garozzo, D.; Waidelich, D.; Glueckmann, M. *Rapid Commun. Mass Spectrom.* **2004**, *18*, 392.

Structure et distribution des oligomères dans le tanin hydrolysable de Tara (*Caesalpinia spinosa*).

Auteurs: S.GIOVANDO, A.PIZZI, H.PASCH, N.PRETORIUS

ProLigno, 9 (1): 22-31 (2013)

Dans cette étude, nous avons examiné un tanin de Tara commercial qui est obtenu par extraction des gousses des fruits de l'arbre *Caesalpinia spinosa* au moyen de solvants organiques.

Les substances contenues dans ce tanin ont été examinées par spectrométrie de masse avec la technique du « Matrix Assisted Laser Desorption/Ionisation Time-of-Flight » (MALDI-TOF) et par chromatographie liquide à haute performance (HPLC). Il ressort de ces analyses que l'extrait de Tara est composé majoritairement d'oligomères de l'acide polygallique attaché par une liaison ester à un acide quinique. D'autres chaînes polygalliques, en très faibles proportions, liées à un seul ou deux motifs répétitifs tels que l'acide caféique méthylé ou non, l'acide quinique et l'acide gallique méthylés, sont également présentes. Le MALDI-TOF en mode ionisation négatif a montré que certains résidus glucidiques semblent toujours présents, liés à la matière polyphénolique de l'extrait, mais leur proportion est très faible, comme on pouvait d'ailleurs s'y attendre d'un tanin extrait par solvant.

S.GIOVANDO, A.PIZZI, H.PASCH, N.PRETORIUS, Structure and oligomers distribution of commercial Tara (*Caesalpinia spinosa*) hydrolysable tanin , *ProLigno*, 9 (1): 22-31 (2013)

**STRUCTURA ȘI DISTRIBUȚIA
OLIGOMERILOR TANINULUI
HIDROLIZABIL DIN SPECIA LEMNOASĂ
TARA (*Caesalpinia spinosa*)**

**STRUCTURE AND OLIGOMERS
DISTRIBUTION OF COMMERCIAL TARA
(*Caesalpinia spinosa*) HYDROLYSABLE
TANNIN**

Samuele GIOVANDO

Dr. - Silva Chimica

Adresa/Address: Via Torre 7, San Michele Mondovi (CN), Italy

Antonio PIZZI*

Prof.Dr. - LERMAB, ENSTIB, University of Lorraine, Epinal, France

Adresa/Address: 27 rue Philippe Seguin, BP 1041, 88051 Epinal cedex 9, France

Tel.: (+33) 329296117. E-mail: antonio.pizzi@enstib.uhp-nancy.fr

Harald PASCH

Prof. - Polymer Research Institute, University of Stellenbosch

Adresa/Address: Stellenbosch, South Africa

Naomi PRETORIUS

Mrs. - Polymer Research Institute, University of Stellenbosch

Adresa/Address: Stellenbosch, South Africa

Rezumat:

Taninul extras cu solvent din specia lemnoasă tara (sortiment comercial) a fost examinat printr-o tehnică de spectroscopie de masă asistată de desorbție/ionizare cu laser (MALDI-TOF) și cromatografie de lichide la presiune ridicată (HPLC). A rezultat că extractul de tara este compus dintr-o serie de oligomeri ai acidului poligalic legați printr-o legătură esterică de acidul quinic. Aceștia constituie oligomerii în proporție ridicată în compoziția taninului. Sunt prezente de asemenea și alte lanțuri de acid poligalic legate de una sau două unități repetate, reprezentate de acidul cafeic și acizii quinic metilat, galic metilat, cafeic metilat. Modul ion negativ MALDI-TOF a arătat că unele reziduuri de carbohidrați ar fi încă prezente, legate de materialul polifenolic al extractului, dar proporția acestora este foarte scăzută, cum era de așteptat la taninul extras cu solvent.

Cuvinte cheie: extract de tara; tanin; taninuri hidrolizabile; structură; lemn; MALDI; HPLC; oligomeri poligalici; acid quinic; *Caesalpinia spinosa*.

INTRODUCERE

Încă de la introducerea sa de către Karas și Hillenkamp în 1987, tehnica de ionizare utilizată în spectroscopia de masă (MALDI) a extins considerabil utilizarea spectroscopiei de masă către studiul moleculelor mari și s-a dovedit a fi o metodă avansată pentru caracterizarea atât a polimerilor sintetici, cât și a celor naturali (Bahr ș.a. 1992, Ehring ș.a. 1992, Danis ș.a. 1992, Danis și Karr 1993, Pasch și Resch 1996, Pasch și Gores 1995).

Abstract:

Solvent extracted commercial Tara tannin extract have been examined by Matrix Assisted Laser Desorption/Ionisation Time-of-Flight (MALDI-TOF) mass spectrometry and by High Pressure Liquid Chromatography (HPLC). The Tara extract has been found to be composed of a series of oligomers of polygallic acid attached by an ester link to one quinic acid. They constitute the oligomers in higher proportion in the extract. Other polygallic chains linked to one only or two repeating units such as caffeic acid and methylated quinic, methylated gallic and methylated caffeic acids are also present. Negative ion mode MALDI-TOF showed that some carbohydrate residues appear to still be present, linked to the polyphenolic material of the extract but their proportion is very low as would be expected of a solvent extracted tannin.

Key words: Tara extract; tannin; hydrolysable tannins; structure; wood; MALDI; HPLC; polygallic oligomers; quinic acid; *Caesalpinia spinosa*.

INTRODUCTION

Since its introduction by Karas and Hillenkamp in 1987, Matrix-Assisted Laser Desorption/Ionization (MALDI) mass spectrometry has greatly expanded the use of mass spectrometry towards large molecules and has revealed itself to be a powerful method for the characterization of both synthetic and natural polymers (Bahr *et al.* 1992, Ehring *et al.* 1992, Danis *et al.* 1992, Danis and Karr 1993, Pasch and Resch 1996, Pasch and Gores 1995). Fragmentation of analyte molecules upon laser irradiation can be

* Autor corespondent / Author to whom all correspondence should be addressed

Fragmentarea moleculelor de analit prin iradierea laser poate fi redusă în mod substanțial, prin înglobarea lor într-o matrice ce absoarbe lumina. Ca urmare, moleculele intacte de analit se desorb și ionizează împreună cu matricea și pot fi analizate cu un spectrometru de masă. Această tehnică de ionizare blândă este combinată cu precădere cu analizoare de masă TOF (viteza ionilor – timpul de zbor depinde de masa particulelor). De aceea, spectroscopia TOF-MS prezintă o serie de avantaje, cum ar fi: capacitatea de a furniza un spectru de masă complet per probă, un domeniu nelimitat de masă, cantitatea mică de analit necesară și costul relativ scăzut al echipamentului. Recent această tehnică s-a dovedit utilă pentru elucidarea structurii taninurilor naturale complexe, precum taninurile flavonoide condensate (Pasch ș.a. 2001, Yeoh Beng Hoong ș.a. 2010, Navarrete ș.a. 2010, Oo ș.a. 2009) și taninurile hidrolizabile (Pasch și Pizzi 2002, Pizzi ș.a. 2009).

Taninul de tara este un agent tanant pentru pielărie, apreciat în mod particular prin culoarea lui foarte deschisă, culoare pe care o imprimă și pieleli tratate cu acesta. Acesta este un produs comercial obținut prin extracția cu solvenți din păstăile arborelui *Caesalpinia spinosa*, această industrie fiind dezvoltată în Peru. Taninul de Tara este un exponent important al familiei taninurilor hidrolizabile derivate din lemn, coajă sau alte materii vegetale (Haslam 1966). Cu toate că structura aproximativă a acestui tanin este știută, există doar câteva publicații referitoare la structura sa (Garro Galves ș.a. 1997, Armitage ș.a. 1961). Dată fiind valoarea lui ridicată nu s-a încercat niciodată o investigare detaliată și o distribuție a oligomerilor în acest extract hidrolizabil.

Această lucrare examinează în detaliu aceste aspecte prin HPLC și metoda spectroscopiei de masă MALDI-TOF.

STUDIUL EXPERIMENTAL

Spectroscopia de masă MALDI-TOF a fost realizată pe probe în condiții prezentate mai jos.

Metoda MALDI-TOF-MS

Spectrul a fost înregistrat pe un instrument tip Shimadzu Biotech AXIMA TOF 2. Sursa de iradiere a fost un laser pulsatoriu cu azot cu lungimea de undă de 337nm. Lungimea unui puls de laser a fost de 3ns. Măsurătorile au fost realizate utilizând următoarele condiții: polaritate pozitivă, deplasare liniară, puterea (voltaj 20kV), 100-150 pulsuri per spectru. Tehnica de extracție întârziată a fost folosită aplicând timpi de întârziere de 200-800ns.

Pregătirea probelor pentru metoda MALDI-TOF

Proba a fost dizolvată în acetonă (4mg/mL, acetonă 50% vol. soluție apoasă). Soluția cu proba a fost amestecată cu o soluție de acetonă (10mg/mL în acetonă) a matricei. Ca matrice s-a folosit acid 2,5 - dihidroxi benzoic. Pentru intensificarea formării

substanțialmente redusă prin înșurșurându-le în o matrice care absoarbe lumina. Ca rezultat moleculele intacte de analit se desorb și ionizează împreună cu matricea și pot fi analizate cu un spectrometru de masă. Această tehnică de ionizare blândă este combinată cu precădere cu analizoare de masă TOF (viteza ionilor – timpul de zbor depinde de masa particulelor). De aceea, spectroscopia TOF-MS prezintă o serie de avantaje, cum ar fi: capacitatea de a furniza un spectru de masă complet per probă, un domeniu nelimitat de masă, cantitatea mică de analit necesară și costul relativ scăzut al echipamentului. Recent această tehnică s-a dovedit utilă pentru elucidarea structurii taninurilor naturale complexe, precum taninurile flavonoide condensate (Pasch ș.a. 2001, Yeoh Beng Hoong ș.a. 2010, Navarrete ș.a. 2010, Oo ș.a. 2009) și taninurile hidrolizabile (Pasch și Pizzi 2002, Pizzi ș.a. 2009).

Tara tannin is a valuable tanning agent for leather particularly appreciated for its very light colour and the very light colour it imparts to leather prepared with it. It is commercially derived by solvent extraction of the pods of *Caesalpinia spinosa*, this industry being particularly developed in Peru. It is an important exponent of the family of hydrolysable tannins derived from wood, bark and other vegetable matter (Haslam 1966). While the approximate structure of this tannin has been known there are only very few publications relating to its structure (Garro Galves *et al.* 1997, Armitage *et al.* 1961). Considering its high value a detailed investigation and distribution of the oligomers in this hydrolysable extract has never been undertaken.

This paper examines in detail these aspects by HPLC and by Matrix Assisted Laser Desorption/Ionisation Time of Flight (MALDI-TOF) mass spectrometry.

EXPERIMENTAL

The Matrix Assisted Laser Desorption Ionisation Time of Flight (MALDI-TOF) mass spectrometry was carried out on this sample according to the following conditions.

MALDI-TOF-MS

The spectrum was recorded on a Shimadzu Biotech AXIMA TOF 2 instrument. The irradiation source was a pulsed nitrogen laser with a wavelength of 337nm. The length of one laser pulse was 3ns. The measurements were carried out using the following conditions: polarity-positive, flight path-linear, mass-high (20kV acceleration voltage), 100-150 pulses per spectrum. The delayed extraction technique was used applying delay times of 200-800ns.

MALDI-TOF Sample Preparation

The sample was dissolved in acetone (4mg/mL, acetone 50% vol. water solution). The sample solution was mixed with an acetone solution (10mg/mL in acetone) of the matrix. As the matrix 2,5 - dihydroxy benzoic acid was used. For the

ionilor s-a adăugat în matrice NaCl (10mg/ml în apă). Soluțiile cu probă și matricea au fost amestecate în proporție de 3 părți soluție de matrice + 3 părți soluție de polimer + 1 parte soluție de NaCl și probe de 0,5 la 1μL din soluția rezultată prin amestecare au fost plasate în ținta MALDI. După evaporarea solventului MALDI a fost introdus în spectrometru. S-a utilizat metoda de pregătire a probei cu picătura uscată.

Pentru a obține masa moleculară a componentelor chimice corespunzătoare maximelor din spectrul de masă înregistrat în modul pozitiv, din valoarea acestor maxime trebuie să fie extrasă valoarea 23Da (1Da = 1,660 538 86 (28)×10⁻²⁷ kg) corespunzătoare ionilor Na⁺ din matrice

Spectrul obținut și interpretarea rezultatelor sunt prezentate în Fig. 1-3, 6 și Tabelul 1.

Înălțimea maximelor de absorbție din spectrul MALDI-TOF este proporțională cu numărul de molecule care formează acel vârf, de aceea, pentru a caracteriza substanța din punct de vedere cantitativ, cantitatea este multiplicată cu masa moleculară a structurii corespunzătoare.

Cromatografia de lichide la presiune ridicată (HPLC)

HPLC din extractul de tara s-a realizat în următoarele condiții:

- s-a folosit apă ultra-pură (tratăată cu un sistem Millipore Milli-Q sau similar);
- sistem HPLC Waters Alliance;
- Coloana: Merck – LiChroCART 125-4 – Lichrospher 100 RP-18 (5μm);
- Detector: Waters 2996 PDA;
- Faza mobilă:

A: Soluții apoase (NH₄)₂HPO₄ / H₃PO₄.

S-au cântărit la o balanță analitică 5.765g de H₃PO₄ și 6.603g de (NH₄)₂HPO₄ într-un pahar de măsură de 100 ml și s-a umplut cu apă. Soluția a fost ulterior diluată 1:100 cu apă (10ml de soluție concentrată la 1000ml într-un balon cotat).

B: Acetonitril – grad de puritate HPLC

C: Acetonitril / Apă 1:1

500 ml de apă la 1000 ml soluție acetonitril, preparată în balon cotat

- eliberare solvent: Waters 2695.

- Eluție (procedeu chimic de eliberare a unei substanțe de pe absorbantul său prin spălare): vezi Tabelul 1.

enhancement of ion formation NaCl was added to the matrix (10mg/ml in water). The solutions of the sample and the matrix were mixed in the proportions 3 parts matrix solution + 3 parts polymer solution + 1 part NaCl solution and 0.5 to 1μL of the resulting solution mix were placed on the MALDI target. After evaporation of the solvent the MALDI target was introduced into the spectrometer. Dry droplet sample preparation method was used.

To each peak value in the resulting positive mode spectrum must be subtracted of 23Da of the Na⁺ of the matrix to obtain the molecular weight of the chemical species of the peak.

The Spectrum obtained and the interpretation of the peaks are shown in Figs. 1-3, 6 and in Table 1.

The height of a MALDI-TOF peak is proportional to the numbers of molecules giving that peak, therefore, in order to characterize the substance quantitatively, the amount is multiplied by the molecular weight of the corresponding structure.

High Pressure Liquid Chromatography (HPLC)

HPLC of tara extract was done under the following conditions:

- ultrapure water was used (treated with Millipore Milli-Q system or similar);
- HPLC system Waters Alliance;
- Column: Merck – LiChroCART 125-4 – Lichrospher 100 RP-18 (5μm);
- Detector: Waters 2996 PDA;
- Mobile phase:

A: Aqueous solution (NH₄)₂HPO₄ / H₃PO₄.

Using an analytical balance weight exactly 5.765 g of H₃PO₄ and 6.603g of (NH₄)₂HPO₄ in a 100 ml glass measuring flask and fill with water. Solution is further diluted 1:100 with water (10 ml of concentrated solution to 1000 ml in volumetric flask).

B: Acetonitrile HPLC grade

C: Acetonitrile / Water 1:1

500 ml of water to 1000 ml acetonitrile solution in volumetric flask

- Solvent delivery: Waters 2695.

- Elution: see Table 1.

Tabelul 1/ Table 1

	TIMP/TIME ⁽¹⁾	DEBIT/FLOW ⁽²⁾	% A	% B	% C	% D	CURV
1		1,00	95	5	0	0	
2	25	1,00	35	65	0	0	7

(1) minutes - (2) mL/min

- Gestionare date : Waters – Empower 2.

REZULTATE ȘI DISCUȚII

Înălțimea vârfului spectrului MALDI-TOF este proporțională cu numărul de molecule care determină acel vârf, prin urmare, pentru a cuantifica

- Data handling: Waters – Empower 2.

RESULTS AND DISCUSSION

The height of a MALDI-TOF peak is proportional to the numbers of molecules giving that peak, therefore, in order to quantify the polymeric

fracția polimerică prin masă, intensitatea relativă a vârfului trebuie să fie multiplicată de masa moleculară a structurii corespunzătoare. Se cunosc un număr de monomeri diferiți care fac parte din structura extractului de tara. Aceștia sunt:

fraction by weight, the peak relative intensity has to be multiplied by the molecular weight of the corresponding structure. A number of different monomers are known to take part in the structure of Tara extract. These are:

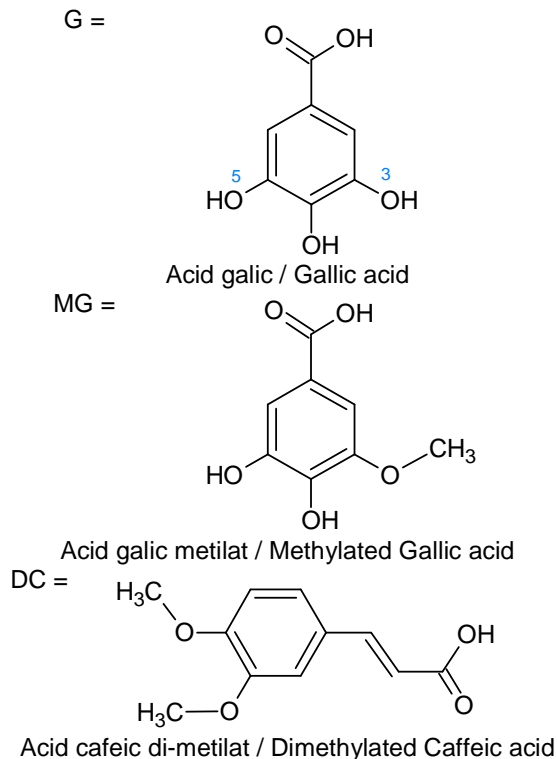
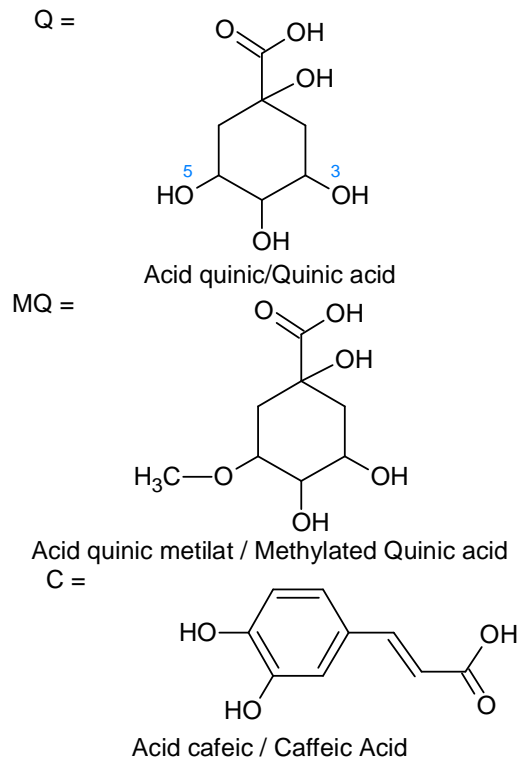

Moleculele de acid quinic și galic sau structurile metilate sunt legate între ele printr-o grupare esterică formată între gruparea acidă a acidului galic și gruparea alcoolică a acidului quinic. Același tip de legătură se formează între gruparea acidă a acidului cafeic și gruparea alcool a acidului quinic (ca și la acidul clorogenic) sau structurile metilate corespunzătoare.

În secvența moleculelor de acid galic (structuri de acid poligalic), o moleculă este legată de altă moleculă prin gruparea ester dintre gruparea acidă a unuia și gruparea alcool a altui acid galic.

În Fig. 1-3 sunt prezentate spectrele în mod pozitiv MALDI-TOF ale extractului de tara. Se poate observa că în acest tanin hidrolizabil sunt prezente molecule repetate de 152Da de acid galic.

Tabelul 2 indică interpretarea spectrelor MALDI-TOF din extract de tara ce rezultă din Fig. 1-3.

Quinic acid and gallic acid units, or the corresponding methylated structures, are linked together by an ester group between the acid group of the gallic acid and an alcoholic group of the quinic acid. The same type of linkage is formed between the acid group of caffeic acid with an alcohol group of the quinic acid (as in chlorogenic acid) or their correspondent methylated structures.

In the sequences of gallic acid units (polygallic acid structures), one unit is linked with another by an ester group between the acid group of one and the alcoholic group of another gallic acid.

In Fig. 1 to 3 are reported the positive MALDI-TOF spectra of Tara extract. It can be observed that in this hydrolysable tannin repeating units of 152Da (gallic acid unit) are present.

Table 2 shows the interpretation of the MALDI-TOF spectra of Tara extract derived from Figs. 1 to 3.

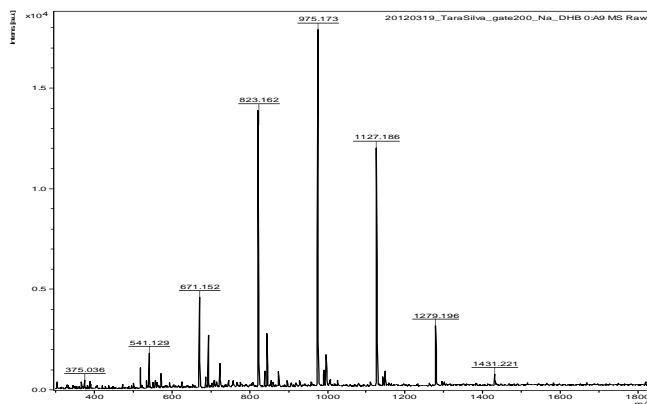

Fig. 1.

Spectrul de masă MALDI-TOF a taninului comercial de tara extras cu solvent (mod pozitiv cu NaCl); domeniul de masă: 300-1850Da / MALDI-TOF (positive mode with NaCl) of solvent-extracted commercial Tara tannin extract; mass range: 300-1850Da.

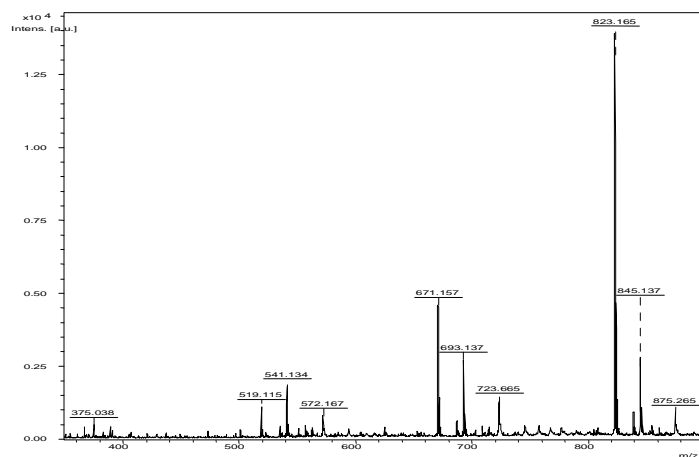

Fig. 2.

Spectrul de masă MALDI-TOF a taninului comercial de tara extras cu solvent (mod pozitiv cu NaCl); detaliu pentru domeniul de masă: 390-900Da / MALDI-TOF (positive mode with NaCl) of solvent-extracted commercial Tara tannin extract; zoomed range: 350-900Da.

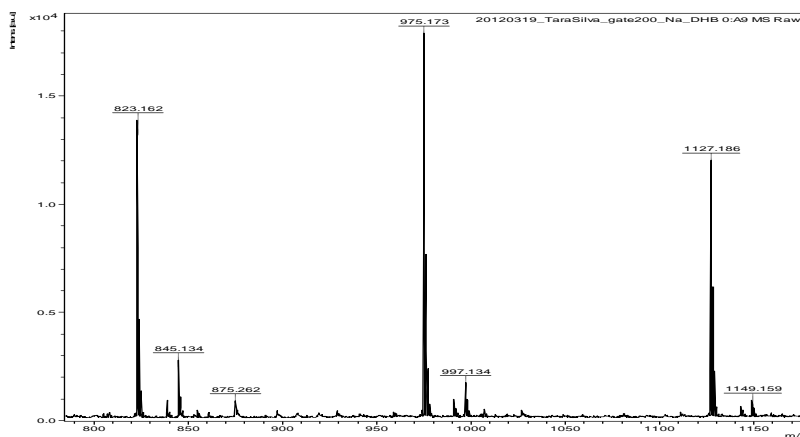

Fig. 3.

Spectrul de masă MALDI-TOF a taninului comercial de tara extras cu solvent (mod pozitiv cu NaCl); detaliu pentru domeniul de masă: 785-1175Da / MALDI-TOF (positive mode with NaCl) of solvent-extracted commercial Tara tannin extract; zoomed range: 785-1175Da.

Tabelul 2 / Table 2

Interpretarea maximelor spectrale ale extractului de tara cu solvent obținute prin metoda MALDI-TOF /
MALDI-TOF peaks interpretation for Tara solvent extract

M+Na+ (exp)	Structura moleculară / Molecular structure	Număr de molecule monomeric/Number of monomeric units	Proporții relative Date primare/Relative Proportions Raw data	Proporții relative % de masă/Relative Proportions % by weight
351,2	G-Q (negative ion mode)	2	2	0,1%
368,7	G-Q (negative ion mode)	2	2	0,1%
375,0	C-Q (Chlorogenic acid)	2	4	0,3%
519,1	Q-G-G	3	9	0,8%
541,1	Q-Q-G	3	15,5	1,5%
572,1	DC-Q-MG	3	6,5	0,7%
671,1	Q-G-G-G	4	40,5	4,8%
685,2	MQ-G-G-G	4	4,5	0,5%
693,1	Q-Q-G-G	4	23	2,8%
723,6	DC-Q-G-MG	4	10,5	1,4%
823,1	Q-G-G-G-G	5	124	18,2%
837,2	MQ-G-G-G-G	5	7	1,0%
845,1	Q-Q-G-G-G	5	24	3,6%
875,2	DC-Q-G-G-MG	5	7	1,1%
975,1	Q-G-G-G-G-G	6	160,5	28,1%
989,2	MQ-G-G-G-G-G	6	7	1,2%
997,1	Q-Q-G-G-G-G	6	14	2,5%
1127,1	Q-G-G-G-G-G-G	7	107	21,7%
1141,2	MQ-G-G-G-G-G-G	7	4	0,8%
1149,1	Q-Q-G-G-G-G-G	7	6,5	1,3%
1279,1	Q-G-G-G-G-G-G-G	8	27	6,2%
1431,2	Q-G-G-G-G-G-G-G-G	9	5	1,3%
			TOTAL	100%

Vârfurile de 519, 671, 823, 975, 1127, 1279 și 1431Da (Tabelul 2) din extractul de tara reprezintă principala serie de structuri care sunt esterii acidului quinic cu incremente de masă de 152Da.

Vârfurile de 541, 693, 845, 997 și 1149Da (Tabelul 2) reprezintă a doua serie de esteri constând din două molecule de acid quinic și o secvență de molecule de acid galic având incremente de masă de 152Da.

Vârfurile de 375, 572, 723 și 875Da (Tabelul 2) aparțin unei alte serii minore în care acidul clorogenic (acid quinic+acid cafeic) este legat de o secvență de molecule de acid galic. Unele molecule sunt parțial metilate.

Vârfurile de 685, 838, 990, 1142 (culoare roz in Tabelul 2) aparțin unei alte serii minore în care o secvență de molecule de acid galic este legată de acid quinic metilat.

Din toate cele de mai sus și incremental evident repetat de 152Da al masei moleculare în seria principală de oligomeri se pare că taninul comercial de tara extras cu solvent conține în principal taninuri hidrolizabile compuse din galotaninuri, în care structura acidului poligalic este esterificată în acid quinic (Fig. 4).

The peaks at m/z of 519, 671, 823, 975, 1127, 1279 and 1431Da (Table 2) in the Tara extract represent the main series of structures that are esters of quinic acid with the mass increments of 152Da.

The peaks at m/z of 541, 693, 845, 997 and 1149Da (Table 2) represent a second series of esters consisting of two quinic acid units and a sequence of gallic acid units having a mass increment of 152Da.

The peaks at m/z of 375, 572, 723 and 875Da (Table 2) belong to another minor series where a chlorogenic acid (quinic acid + caffeic acid) is linked with a sequence of gallic acid units. Some units are partially methylated.

The peaks at m/z of 685, 838, 990, 1142 (pink series in Table 2) belong to another minor series where the sequence of gallic acid units is linked with a methylated quinic acid.

From all the above and the evident 152Da repeating jump in molecular weight in the main series of oligomers it appeared that solvent extracted commercial Tara tannin contains mainly hydrolysable tannins composed by gallotannins, where a polygallic acid structure is esterified on quinic acid (Fig. 4).

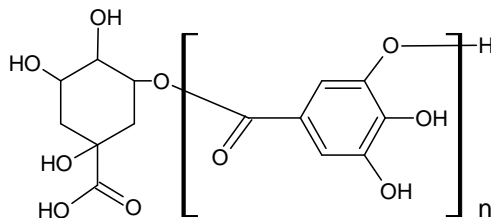

Fig. 4.

Structura principală a galotaninurilor prezente în taninul de tara / Main structure of gallotannins present in Tara tannin.

Prin urmare, cel mai înalt vârf (maxim) spectral detectat în extractul comercial corespunde unei serii de structuri prezentate în Fig. 5, respectiv o succesiune de molecule de acid galic, unde n din Fig. 4 poate varia de la 0 la 8. În loc de acid quinic pot fi de asemenea alte molecule de monomer, dintre celelalte indicate mai sus, la care aceste lanțuri de acid poligalic pot fi atașate prin legături esterice.

Thus the highest peaks detected in the commercial extract corresponds to the series of structures shown in Fig. 5, namely a sequence of gallic acid units, where n of Fig. 4 can vary from 0 to 8. Instead of quinic acid, there can also be other monomeric units among the other indicated above on which these polygallic acid chains can be attached by ester linkages.

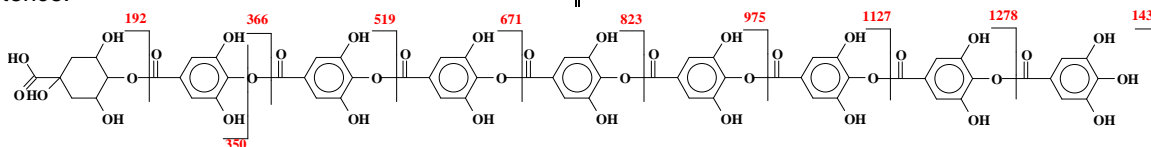

Fig. 5.

Serie de oligomeri reprezentând cele mai înalte vârfuri și masele moleculare corespunzătoare în taninul comercial de tara extras cu solvent. Secvența moleculelor de acid galic, unde n poate varia de la 0 la 8, poate fi legată de alte molecule de monomer în loc de acid quinic, similar structurii din figură corespunzătoare principalei serii de oligomeri / Series of oligomers representing the highest peaks and their respective molecular weights in solvent extracted commercial Tara tannin extract. The sequence of gallic acid units, where n can vary from 0 to 8. can be linked to other monomer units instead than to quinic acid as shown in the figure for the main series of oligomers.

Spectrul în mod ion negative arată cum o serie de carbohidrați pot fi prezenți și legați la fracțiunea polifenolică a extractului. De aceea, din spectrul în mod (Fig. 6) se poate observa o serie de vârfuri minore care corespund aducțiilor carbohidrați - polifenoli. Seria de vârfuri indicând legături cu carbohidrații, este reprezentată prin vârfuri foarte mici. Acest lucru este exemplificat prin vârfurile de 839Da și 855Da. Primul dintre acestea, prezentat mai jos în Fig. 7, spre exemplu, reprezintă aductul sodiului la structura diglucozei la care se leagă un lanț rezidual din trei unități de acid galic, iar al doilea un compus similar, minus o grupare -OH. Cel mai mic dintre vârfuri arată că proporția de carbohidrați în extractul de tara cu solvent este într-adevăr foarte scăzută, cum era de așteptat. Aceleiași serii îi aparține și vârful mai pronunțat 687Da reprezentând o diglucoză legată de două reziduuri de acid galic și 535Da (diglucoza legată la un singur acid galic). Vârfurile de 368Da și 350Da corespund dimerilor acidului quinic și galic (Tabelul 2, Fig. 5) fără carbohidrați atașați. De remarcat este vârful de 700Da care este o unitate Q-G-G-glucoză.

The negative ion spectra defines how some carbohydrates may be present and linked to the polyphenolic fraction of the extract. Thus from the negative spectra (Fig. 6) one can notice a series of minor peaks that correspond to carbohydrates polyphenolic adducts. The series of peaks indicating linking with the carbohydrates is represented by very small peaks. This is exemplified by the peaks at 839Da and 855Da. The first one of this, shown hereunder in Fig. 7 for example, represents the sodium adduct of a diglucose structure to which is linked a three gallic acid residues chain and the second the same minus a -OH group. The smallness of such peaks indicates that the proportion of carbohydrates in tara solvent extract is indeed very low, as would be expected. To the same series belong the more pronounced 687Da peak representing a diglucose linked to two gallic acid residues, the 535Da peaks (a diglucose linked to a single gallic acid). The peaks at 368Da and 350Da correspond to dimers of quinic and gallic acid (Table 2, Fig. 5) without carbohydrates attached. Noticeable are also a peak at 700Da that is a Q-G-G-glucose.

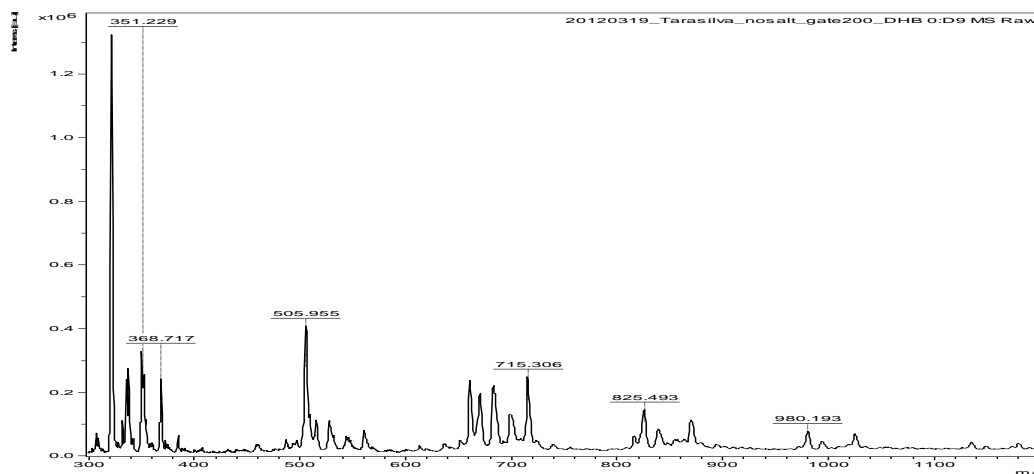

Fig. 6.

Spectrul MALDI-TOF al tandinului comercial de tara extras cu solvent (mod negativ, cu NaCl); domeniul de masă: 300-2000Da / MALDI-TOF of solvent extracted commercial Tara tannin extract (negative mode, with NaCl); mass range: 300-2000Da.

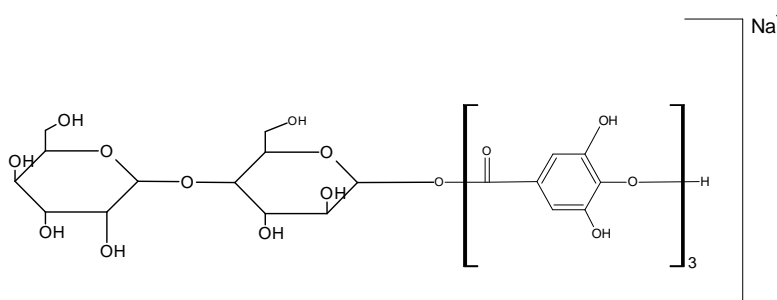

Fig. 7.

Structura propusă pentru trimerul corespunzător vârfului minor 839Da, rezultată prin analiza MALDI-TOF în mod ion negativ a tandinului comercial de tara extras cu solvent / Proposed structure for the trimer at 839Da, minor peak, as postulated from the bulk sample of negative ion MALDI-TOF analysis of solvent extracted commercial Tara tannin extract.

Interesantă este și cromatograma HPLC a tandinului de tara extras cu solvent prezentată în Fig. 8. Vârful ce aparține acidului galic cu un timp de retenție de 2,2 minute și acidului clorogenic cu un timp de retenție de 1,5 minute sunt clar vizibile. Suprafața picului indică o proporție de 1,6% de acid galic liber și de 0,48% de acid clorogenic liber în compoziția tandinului de tara extras cu solvent. Este interesant de notat că numărul de vârfuri prezente în Fig. 8, aproximativ 20, corespunde unui număr similar de oligomeri identificați prin metoda MALDI-TOF. Cum picurile de absorbție cu arie maximă din cromatograma din Fig. 8 sunt la 10, 13,5 și 15,25 minute ca timp de eluție, se poate presupune că acestea corespund oligomerilor prezenți în proporție mare, identificați prin metoda MALDI-TOF, prin urmare corespunzând valorilor 823Da, 975Da și 1127Da, deși nu s-a putut face o atribuire clară.

Of interest is also the HPLC chromatogram of solvent extracted Tara tannin shown in Fig. 8. The peaks belonging to gallic acid of retention time 2.2 minutes and of chlorogenic acid of retention time 10.6 minutes are clearly visible. The peak areas indicate a proportion of 1.6% of free gallic acid and of 0.48% of free chlorogenic acid as present in solvent extracted Tara tannin. It is of interest to note that the number of peaks present in Fig. 8, approximately 20, correspond to a similar number of oligomers identified by MALDI-TOF. As the peaks of major area in the chromatogram in Fig. 8 are those at 10, 13.5 and 15.25 minutes elution it can be postulated that such peaks correspond to the oligomers present in greater proportion as obtained by MALDI-TOF, thus corresponding to the 823Da, 975Da and 1127Da, although a clear assignment cannot be done.

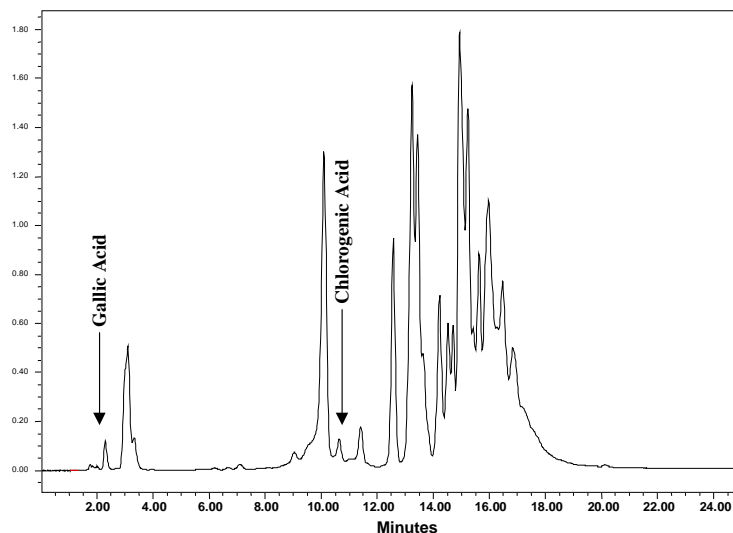

Fig. 8.

Diagrama de eluție HPLC a taninului comercial de tara extras cu solvent. Săgețile indică picurile corespunzătoare monomerilor acidului galic și acidului clorogenic / HPLC elution diagram of solvent extracted commercial Tara tannin extract. Arrows indicate the peaks of the monomers of gallic acid and chlorogenic acid.

CONCLUZII

S-a determinat că taninul comercial de tara extras cu solvent este compus dintr-o serie de oligomeri ai acidului galic atașați prin legătura esterică de acidul quinic. Ei constituie oligomerii cu cea mai mare proporție în extract. Alte lanțuri poligalice legate la una sau două molecule repetate precum acidul cafeic și acidul metil-quinic, metil-galic metil-cafeic sunt de asemenea prezente. Unele reziduuri de carbohidrați apar ca fiind încă prezente, legate de structura polifenolică de bază a extractului, dar proporția lor este foarte scăzută, așa de cum era de așteptat la taninul extras cu solvent.

CONCLUSION

Solvent extracted commercial Tara tannin extract has been found to be composed of a series of oligomers of polygallic acid attached by an ester link to one quinic acid. They constitute the oligomers in higher proportion in the extract. Other polygallic chains linked to one only or two repeating units such as caffeic acid and methylated quinic, methylated gallic and methylated caffeic acids are also present. Some carbohydrate residues appear to still be present, linked to the polyphenolic material of the extract but their proportion is very low as would be expected of a solvent extracted tannin.

BIBLIOGRAFIE / REFERENCES

- Armitage R, Bayliss GS, Gramshaw JW, Haslam E, Haworth RD, Jones K, Rogers HJ, Searle T (1961) Gallotannins, Part III. The constitution of Chinese, Turkish, Sumach and Tara tannin. J.Chem.Soc. 1842-1853.
- Bahr U, Deppe A, Karas M, Hillenkamp F, Giessmann U (1992) Mass Spectrometry of Synthetic Polymers by UV-Matrix-Assisted Laser Desorption/Ionization. Anal. Chem. 64:2866-2869.
- Danis PO, Karr DE, Mayer F, Holle A, Watson CH (1992) The analysis of water-soluble polymers by matrix-assisted laser desorption time-of-flight mass spectrometry. Org. Mass Spectrom. 27:843-846.
- Danis PO, Karr DE (1993) A facile sample preparation for the analysis of synthetic organic polymers by matrix-assisted laser desorption/ionization. Org. Mass Spectrom. 28:923-925.
- Ehring H, Karas M, Hillenkamp F (1992) Role of photoionization and photochemistry in ionization processes of organic molecules and relevance for matrix-assisted laser desorption/ionization Org. Mass Spectrom. 27:472-480.
- Garro Galves JM, Riedl B, Conner AH (1997) Analytical studies on Tara tannin. Holzforschung, 51:235-240.
- Haslam E (1966) The Chemistry of Vegetable Tannins. Academic Press, London.
- Karas M, Bachmann D, Bahr U, Hillenkamp F (1987) Matrix-assisted ultraviolet laser desorption of non-volatile compounds Int. J. Mass Spectrom. Ion Proc. 78:53-68.

Navarrete P, Pizzi A, Pasch H, Rode K, Delmotte L (2010) MALDI-TOF and ¹³C NMR characterisation of maritime pine industrial tannin extract, *Ind. Crops Prod.* 32:105-110.

Oo CW, Kassim MJ, Pizzi A (2009) Characterization and performance of *Rhizophora apiculata* mangrove polyflavonoid tannins in the adsorption of copper (II) and lead (II), *Ind. Crops & Prod.* 30:152-161.

Pasch H, Resch M (1996) Polymer Analysis with MALDI-MS. *GIT Fachz. Lab.* 40:90-94.

Pasch H, Gores F (1995) Matrix-Assisted Laser Desorption/Ionization Mass Spectrometry of Synthetic Polymers. 2. Analysis of Polymethyl Methacrylate. *Polymer* 36:1999.

Pasch H, Pizzi A, Rode K (2001) MALDI-TOF mass spectrometry of polyflavonoid tannins, *Polymer.* 42:7531-7539.

Pasch H, Pizzi A (2002) On the macromolecular structure of chestnut ellagitannins by MALDI-TOF mass spectrometry, *J.Appl.Polymer Sci.* 85:429-437.

Pizzi A, Pasch H, Rode K, Giovando S (2009) Polymer structure of commercial hydrolysable tannins by MALDI-TOF mass spectrometry, *J.Appl.Polymer Sci.* 113(6):3847-3859.

Yeoh Beng Hoong, Pizzi A, Tahir PMd, Pasch (H 2010) Characterisation of *Acacia mangium* polyflavonoid tannins by MALDI-TOF mass spectrometry and CP-MAS ¹³C NMR, *Eur.Polymer J.* 46:1268-1277.

Nouvelles résines de tanins écosoutenables.

Résines pour adhésifs phénoliques basés sur les tanins hydrolysables de châtaignier.

Auteurs: S.SPINA, X.ZHOU, C.SEGOVIA, A.PIZZI, M.ROMAGNOLI, S.GIOVANDO, H.PASCH, K.RODE, L.DELMOTTE

Intern.Wood Prod.J., (2013) VOL 4 NO 2

DOI: 10.1179/2042645312Y.0000000020

Dans ce travail, nous avons étudié la possibilité d'utiliser le tanin de châtaignier, comme substitut partiel du phénol, dans la production des résines phénoliques.

Le tanin de châtaignier est de type hydrolysable et il est constitué de matériaux phénoliques qui ont été considérés, jusqu'à maintenant, comme trop peu réactifs pour être intéressants dans le marché des résines phénoliques et des adhésifs pour panneaux extérieurs dans l'industrie du bâtiment. Cependant, lors de la première crise pétrolière, un article de 1973 décrivant 3 ans d'application industrielle de tanins hydrolysables de châtaignier, avait indiqué que leur réactivité n'était pas si mauvaise. Ce travail, déjà un peu ancien, a été étendu ici en utilisant des formulations de résines phénoliques de qualité supérieure pour la fabrication d'adhésifs à base de tanin de châtaignier-phénol-formaldéhyde où une substitution du phénol pouvant aller jusqu'à 80% est possible avec des résultats remarquablement bons. Les réactions mises en jeu ont été clarifiées par ¹³C-RMN et MALDI-TOF.

En fait, le phénol synthétique et le tanin hydrolysable de châtaignier co-réagissent avec le formaldéhyde, formant des ponts méthylène reliant le phénol et les noyaux phénoliques du tanin. Cela s'est avéré remarquable pour deux raisons: (1) en dépit de la réactivité relativement faible des cycles aromatiques phénoliques du tanin, ceux-ci co-réagissent avec le formaldéhyde pour former des ponts méthylène avec le phénol, et (2) de façon encore plus remarquable, le

tanin hydrolysable réagit par ses sites méta, supposés être moins réactifs, mais seuls sites aromatiques du tanin encore disponibles pour la réaction.

En conclusion, cette étude montre que les tanins hydrolysables comme le tanin de châtaignier, semblent en mesure de substituer une forte proportion de phénol synthétique dans les résines PF pour les panneaux de particules.

S.SPINA, X.ZHOU, C.SEGOVIA, A.PIZZI, M.ROMAGNOLI, S.GIOVANDO, H.PASCH, K.RODE, L.DELMOTTE, Phenolic resin adhesives based on chestnut hydrolysable tanins, *Intern.Wood Prod.J.*, (2013) , VOL 4 NO 2, DOI: 10.1179/2042645312Y.0000000020

Phenolic resin wood panel adhesives based on chestnut (*Castanea sativa*) hydrolysable tannins

S. Spina^{1,2}, X. Zhou², C. Segovia², A. Pizzi*², M. Romagnoli¹, S. Giovando³, H. Pasch⁴, K. Rode⁵ and L. Delmotte⁶

Chestnut hydrolysable tannins are phenolic materials that have been considered too unreactive to compete in the phenolic resin adhesives market for exterior boards for the building industry. However, an article in 1973 describing 3 years of industrial application of chestnut hydrolysable tannins during the first oil crisis indicated that this was not the case. This previous work has been extended by using superior phenolic resins formulations and producing phenol–formaldehyde–chestnut tannin adhesives where a substitution of up to 80% of the phenol is possible with remarkably good results. The reactions involved were clarified by ¹³C NMR and MALDI–TOF mass spectrometry.

Keywords: Chestnut tannin, Hydrolysable tannins, Wood adhesives, Wood panel adhesives, Phenolic resins

Introduction

In 1973, as a consequence of the first oil crisis, Nor-sechem, a Norwegian paint group subsidiary in Malaysia that produced phenol formaldehyde (PF) resins for Southeast Asia plywood manufacturers, was forced to implement a technological change that was utilized for three years in industrial production (Kulvik 1976). This technology consisted of substituting 33 wt-% of phenol with chestnut tannin extract in the PF resin during its preparation. Up to 50% substitution in the laboratory was claimed but no glue mix or other information was given (Kulvik 1976). The motive of this was purely economical, as phenol prices had skyrocketed and the cost of chestnut tannin extract was much lower. In the only written reference that exists relative to this development (Kulvik 1976), results and basic material proportions are reported, but resin formulations are not disclosed.

The use of chestnut tannin extract in this context is particularly intriguing, as this is the most expensive of all the natural tanning agents for leather due to the very light coloured leather it yields. Its use is even more intriguing if one considers: (1) the development of

cheaper and more abundant condensed or flavonoid tannin adhesives, which are far more reactive than hydrolysable tannins, and were in extended industrial use at the same time (Pizzi and Scharfetter, 1978; Pizzi 1977, 1979, 1983, 1999); and (2) the low reactivity of the phenolic rings in hydrolysable tannins and relatively high proportion of carbohydrates that are inseparably linked to their phenolic part.

Hydrolysable commercial tannin extracts are mixtures of esters of a sugar, mainly glucose, with simple phenols such as gallic and digallic acids, and also with more complex structures containing ellagic acid (Fengel and Wegener 1984; Pasch *et al.* 2001; Pizzi *et al.* 2009) (Scheme 1).

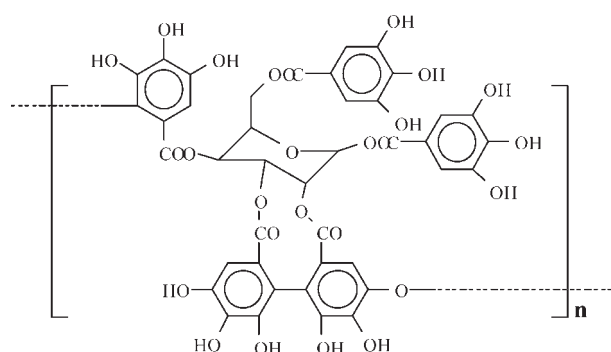

For many decades, hydrolysable tannins were considered to be mainly formed of phenolic esters of simple sugars such as glucose. Their alleged lack of a polymeric structure, although it could still result in complex structures, caused them to be considered unsuitable for adhesives (Pizzi 1983). Once the first oil crisis had passed and the price of phenol became affordable again, the

¹DAF, Faculty of Agriculture, via San Camillo de Lellis, University of Tuscia, 01100 Viterbo, Italy

²ENSTIB-LERMA, University Henri Poincaré – Nancy 1, 27 rue Philippe Seguin, BP 1041, 88051 Epinal, France

³CRCF (SILVA Team), Via Torre 7, 12080 San Michele Mondovì, Italy

⁴Department of Chemistry and Polymer Science, University of Stellenbosch, Private Bag X1, 7602 Matieland, Stellenbosch, South Africa

⁵Deutsches Kunststoff-Institut, Abteilung Analytik, Schlossgartenstr. 6, 64289 Darmstadt, Germany

⁶IS2M, CNRS LRC 7228, 15 rue Jean Starcky, BP 2488, 68057 Mulhouse, France

*Corresponding author, email antonio.pizzi@enstib.uhp-nancy.fr

phenol formaldehyde (PF)–chestnut tannin adhesive production was stopped, and interest in this resin had waned by 1977. Recently, however, their extensive polymeric structure based on pentagalloyl glucose repeat units has been clearly determined (Pizzi *et al.* 2009). Thus, in a situation where other types of tannins, e.g. condensed tannins, are relatively scarce due to the growing interest in environment friendly adhesives, revival of the PF–chestnut tannin extract technology is a useful exercise, given the abundance of chestnut trees in Europe.

This study re-examines the PF–chestnut tannin extract technology by: (1) developing and optimizing the resin formulation and synthesis using modern PF resins formulations; (2) drastically and progressively decreasing the relative proportions of phenol and increasing those of chestnut tannin extract to obtain even higher proportions of natural material; (3) determining if coreaction of phenol and phenolic tannin occurs or not. This is a crucial question as (1) the hydrolysable tannin aromatic rings (both monomer as well as bound in natural oligomers), are less reactive than the reactive sites of phenol; and (2) only the much less reactive *meta*-sites are still free in the main phenolic unit of chestnut tannin, namely, gallic acid, of structure

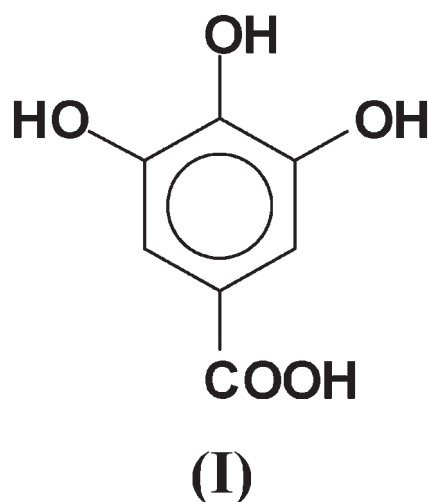

and (4) applying for the first time such improved and optimised adhesives to wood particleboards, more complex but much faster pressing panels than plywood for which these adhesives were originally developed.

Experimental

Resin preparation

Commercial chestnut (*Castanea sativa*) wood tannin extract spray dried powder obtained from SILVA Chimica (S. Michele Mondovi, Italy) was used for the purpose. The resins based on PF/chestnut tannin extract were prepared according to the following procedure: 85 g chestnut tannin extract and 85 g 90% phenol were dissolved in a solution of water–methanol (62.7 g water and 9.6 g methanol) to which were then added 95.5 g paraformaldehyde powder (96% purity; Degussa N, Düsseldorf, Germany) premixed with 4 g water. The reaction mixture was first heated at 40°C for 30 min, under continuous mechanical stirring in a glass reactor

equipped with a reflux condenser. The mixture was then heated until the temperature reached 94°C, and then 45.2 g of 30% aqueous NaOH solution was added in four equal lots at intervals of 15 min. After the addition of the last lot of NaOH solution (45 min from the start of NaOH addition), the reaction mixture was heated for additional 15 min to reach a total of 1 h reaction time. After a further 15 min reaction, the mixture was cooled and stored. The resin obtained had viscosity at 25°C of 550–600 cP, solid content of 61% and pH of 8.6 which was then adjusted to pH 11 by addition of 18.4 g 30% NaOH aqueous solution. This pH adjustment caused a decrease in solids content to 55.8% and of viscosity to 375–400 cP.

Resins in which the effective weight proportions of phenol/chestnut tannin extract were 50:50, 45:55, 40:60, 30:70, 20:80, 10:90 and 0:100 were prepared and tested, while the relative proportions of formaldehyde, water, methanol and sodium hydroxide were maintained constant for all resins.

MALDI-TOF sample preparation

The resin was dried in two different ways. For the first sample, water/methanol was evaporated under vacuum at 40°C on a rotary evaporator, to minimise curing and to be able to better examine the resin oligomer's distribution. The second sample was allowed to dry in the oven at 105°C for 16 h and then ground to fine powder to study oligomer's distribution once the resin had cured.

These resin samples were dissolved in acetone/water (4 mg mL⁻¹, 50:50 acetone/water by volume). The sample solutions were mixed with an acetone solution of 2,5-dihydroxy benzoic acid (10 mg mL⁻¹ in acetone). For the enhancement of ion formation, NaCl was added to the matrix (10 mg mL⁻¹ in water). The solutions of the sample and the matrix were mixed in the proportions 3 parts matrix solution+3 parts polymer solution+1 part NaCl solution. A small amount (0.5–1 µL) of the resulting solution mix was placed on the MALDI target. After evaporation of the solvent, the MALDI target was introduced into the spectrometer. From each peak value in the resulting positive mode spectrum, 23 Da of the Na⁺ of the matrix must be subtracted to obtain the molecular weight of the chemical species of the peak.

MALDI-TOF-MS analysis

The spectra were recorded on a KRATOS Kompact MALDI AXIMA TOF 2 instrument. The irradiation source was a pulsed nitrogen laser with a wavelength of 337 nm. The time period of a laser pulse was 3 ns. The measurements were carried out using the following conditions: polarity positive, flight path linear, mass high (20 kV acceleration voltage), 100–150 pulses per spectrum. The delayed extraction technique was used by applying delay times of 200–800 ns.

CP-MAS¹³C NMR

Solid state CP-MAS (cross-polarisation/magic angle spinning) ¹³C NMR spectra of the oven-dried resin were recorded on a Bruker MSL 300 spectrometer at a frequency of 75.47 MHz. Chemical shifts were calculated relative to tetramethyl silane. The rotor was spun at 4 kHz on a double bearing 7 mm Bruker probe. The spectra were acquired with 5 s recycle delays, a 90° pulse of 5 µs and a contact time of 1 ms. The number of transients was 3000.

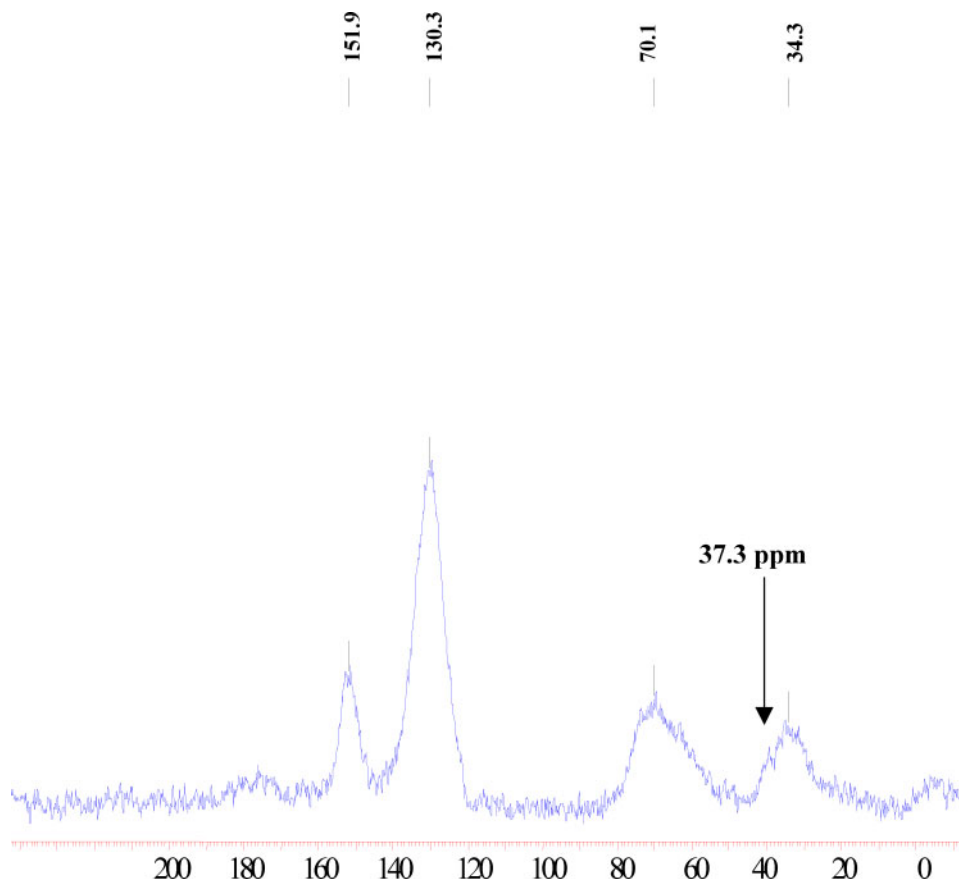

1 CP-MAS ^{13}C NMR spectrum of oven dried 45/55 PF/chestnut tannin adhesive: band at 37.3 ppm corresponds to calculated NMR shift for methylene bridges linking two gallic acid aromatic rings

Thermomechanical (TMA) analysis

The hardening reactions of different resin systems were evaluated by TMA, by following the progressive hardening of a resin bonded wood joint as a function of temperature. All experiments were conducted under the same conditions: heating rate = $10^\circ\text{C min}^{-1}$, 30 mg of resin system, and temperature range of 25–250°C. TMA analyser used was a TMA40 instrument from Mettler Toledo. The software used for data treatment was STARE. Deflection curves that permit modulus of elasticity (MOE) determination were obtained by three-point bending of the joint formed by two beech wood veneers, dimensions $21 \times 6 \times 0.6$ mm each, between which the liquid resin was inserted. The MOE of resin bonded wood joints gives an indication of the performance of the adhesive.

It has been shown that the maximum MOE value and its increase as a function of time or temperature for resin bonded wood joints gives a good indication of the possible end performance of the adhesive system tested (Pizzi 1997, 1999; Pizzi *et al.* 1997; Laigle *et al.* 1998; Garnier *et al.* 2001; Lecourt *et al.* 2003). Values in excess or close to 4000 MPa have been shown to indicate the applicability of the resins for the manufacture of wood particleboard (Laigle *et al.* 1998; Garnier *et al.* 2001; Lecourt *et al.* 2003).

Wood particleboard preparation and testing

One-layer laboratory particleboards of dimensions $350 \times 300 \times 14$ mm were prepared using a wood mixture of core particles of beech (*Fagus sylvatica*) and Norway spruce (*Picea abies*) at 28 kg cm^{-2} maximum specific

pressure and 195°C press temperature. The resin solids content was maintained at 10% of the total mix. The total press time was kept at 7.5 min. All particleboards were tested for internal bond (IB) strength on an Instron 3369 test machine (Instron, High Wycombe, UK). First, a 45/55 PF/chestnut adhesive was formulated to prepare 10 laboratory panels. Afterwards, triplicate panels with adhesive formulations containing a decreasing proportion of phenol were tested. For accelerated ageing tests, specimens were boiled in water for 2 h, dried at 103°C for 16 h and tested for residual internal bond strength using an Instron 3369 test machine (Instron).

Results and discussion

The CP-MAS ^{13}C NMR spectrum (Fig. 1) of the oven dried 45/55 PF/chestnut tannin extract resin indicated the following: the band at 151 ppm belonging to the aromatic carbon linked to a phenolic –OH, for both the tannin and the PF resin. The very pronounced 130 ppm band belongs to all the unreacted *meta*- sites and reacted *ortho* and *para* sites on the aromatic phenolic rings. The bands at 120 and 115 ppm, which are characteristic of still free, unreacted *ortho* and *para* sites respectively, do not appear at all, indicating that these sites had completely reacted. The large band at 70 ppm is given by the superposition of the carbohydrate part of the chestnut extract and of the methylol groups (–CH₂OH) present on the reacted *ortho* and *para* sites of both phenol and the phenolic fraction of the tannin. Finally, the band centred at 34 ppm is composed of a series of

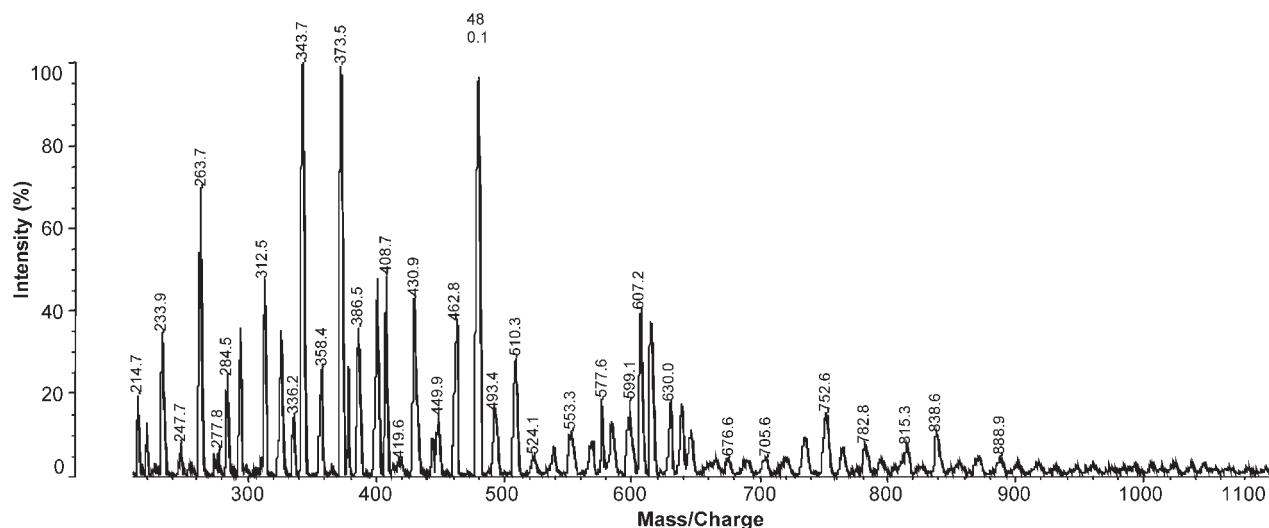

2 MALDI-TOF spectrum of air dried 45:55 PF/chestnut tannin adhesive

superimposed bands one of which is clearly visible as a separate peak at 37.3 ppm. This one corresponds to methylene bridges linking gallic acid ring sites (theoretically calculated values for these methylene bridges is 37.33 ppm (ChemWindows, 1998) and is indicated with an arrow in the spectrum in Fig. 1. The band at 40 ppm belongs to the *para-para* methylene bridges between phenols of the synthetic PF component of the hardened network. The band at 34 ppm belongs to *ortho-para* PF methylene bridges that are in greater proportion. These methylene bridges are between phenol and phenol (40 and 34 ppm), phenol and tannin (37.3 ppm), and tannin and tannin (37.3 ppm). Thus, given the broadness of these bands, the phenol and the phenolic fraction of the tannin appear to have coreacted, confirming the reason why such a resin had hardened.

Further and definitive confirmation of coreaction of tannin and phenol is obtained by the MALDI-TOF spectrum of the same resin. MALDI-TOF analysis can be performed in either positive or negative ion modes (Pizzi et al. 2009). In the case of hydrolysable tannins, the positive mode spectrum shows what happens to the phenolic component of the material, while negative ion mode analysis shows what happens to the polymeric carbohydrates of the system (Pizzi et al. 2009). Positive mode MALDI-TOF analysis is commonly performed, as is the case in this article, while negative mode is used rarely. Thus, Figs. 2 and 3 and Table 1 shows the oligomers that are formed from the phenolic component of the phenol-tannin-formaldehyde resin during the preparation and hardening of the resin. Table 1 also shows the relative percentages of an air dried resin (not cured but simply dried after preparation) and of an oven cured resin. The first conclusion that can be drawn is that a number of coreacted phenol-tannin oligomers are formed, confirming the NMR result (Fig. 1). The tannin contribution is indicated as 'G' (for gallic acid) this being calculated as gallic acid equivalents (Table 1). Thus, definitely belonging to coreacted mixed species are the series of peaks at 299, 312, 406, 480, 493, 510, 534, 552, 566, 577, 59, 607, 620, 769, 782, 799, 888 and 958 Da, constituting 66% of the total number of species of the polymer and 50% of the total mass of the polymer. Mixed species may also contribute to the peaks

at 327 and 403 Da. The rest of the peaks belong to pure PF oligomers.

The first point of interest of all these observations is that a species such as gallic acid (structure I), which has both sterically hindered sites and those in *meta* position to some of the phenolic -OH groups, is rather reactive and forms through these *meta* sites methylene bridges with the *ortho* and *para* sites of the synthetic phenol. This indicates that hydrolysable chestnut tannin phenolic aromatic rings are far more reactive than originally thought (Pizzi 1977).

Table 2 shows the maximum MOE values obtained during TMA curing of the PF/chestnut extract resins. It can be observed that the maximum MOE value obtained is 4135 MPa for resins in which the PF/chestnut extract weight proportion is 40:60, which strongly demonstrates their capability for use for the manufacture of particleboard panels of good quality. Table 2 also reports the average values of maximum MOE obtained by TMA for resins in which the relative proportions of phenol to chestnut varied during the preparation of the resin. Thus, the average maximum MOE value, which is directly correlatable to the IB strength of wood particleboard panels (Zhao et al. 1998; Garnier et al. 2001) varied only little when chestnut tannin was up to 60% of the total material and decreased with greater proportions of chestnut tannin in the resin. The maximum value of the MOE starts to be slightly lower, but still very good for the 35:65 adhesive formulation but starts to decrease rather markedly for the 30:70 adhesive formulation and for formulations with even higher proportions of hydrolysable chestnut tannin. The results for the experimental laboratory particleboards (Table 3) support the TMA results. Thus, wood particleboard prepared with a 45:55 PF/chestnut tannin extract adhesive yielded average dry IB strength of 0.58 MPa for an average density of 688 kg m⁻³ (Table 3). This is considerably above the 0.35 MPa required by international wood particleboard standards for the same type. The 40:60 adhesive formulation also produced panels that satisfied well the dry IB strength requirements of relevant the European Norm (P2) (EN 312, 1995). However, the 30:70 phenol/tannin adhesive formulation gave results that were just close to the European Norm

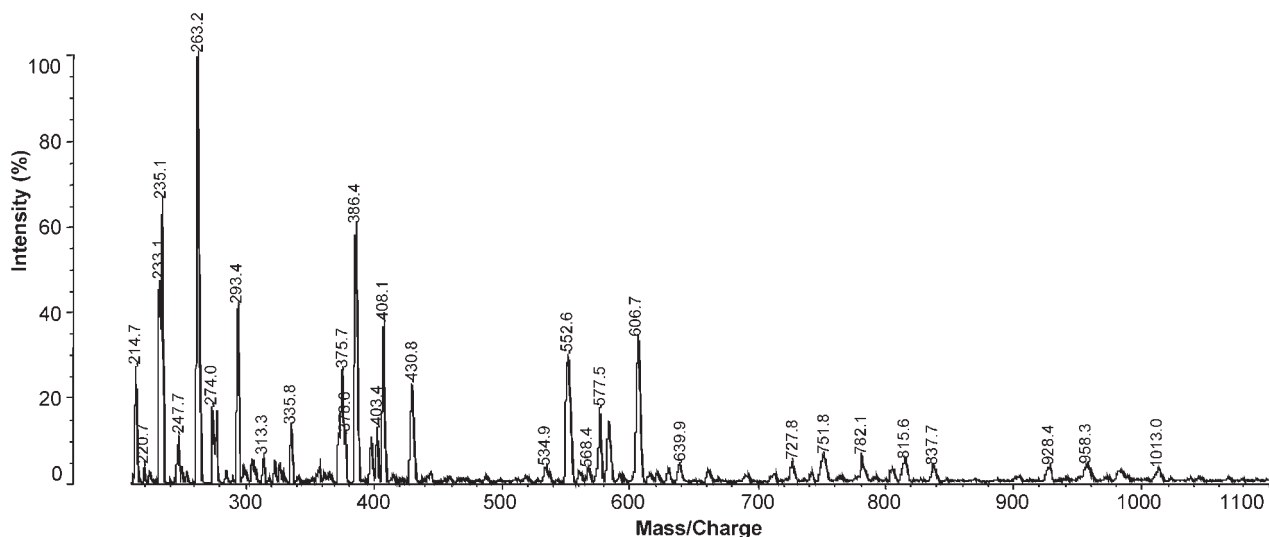

3 MALDI-TOF spectrum of oven-dried 45:55 PF/chestnut tannin adhesive

Table 1 MALDI-TOF spectrometry peaks, corresponding oligomers formed, and their relative percentage proportions for a 45:55 PF/chestnut tannin resin reacted for 68 min

M+Na ⁺ (expl.)	M+Na ⁺ (calc.)	Relative proportion/%		Oligomer type
		Air dried	Oven dried	
<u>233.9–235</u>	236	3.5	18.7	PCH ₂ PCH ₂ ⁺
<u>263.7</u>	264	7.1	16.3	HOCH ₂ PCH ₂ PCH ₂ ⁺
<u>277.8</u>	277	0.7	2.8	HOCH ₂ PCH ₂ P(CH ₂ ⁺) ₂
299*		3.8	6.8	GCH ₂ P
<u>312.5*</u>		4.7	1.1	GCH ₂ PCH ₂ ⁺
<u>327*</u>		3.5	0.8	GCH ₂ PCH ₂ OH
329				or GCH ₂ OCH ₂ P
343.7		9.9	...	PCH ₂ PCH ₂ P
358.4	359	2.8	2.3	PCH ₂ PCH ₂ PCH ₂ ⁺
<u>373.5</u>	373.7	9.8	2.8	PCH ₂ PCH ₂ PCH ₂ OH
<u>375*</u>	375	2.7	4.4	HOCH ₂ PCH ₂ PCH ₂ PCH ₂ ⁺
<u>386.5</u>	387	3.6	9.9	GCH ₂ G
<u>403.5*</u>	403	4.7	2.4	HOCH ₂ PCH ₂ PCH ₂ P(CH ₂ ⁺) ₂
406.5*		4.8	6.3	or (HOCH ₂) ₂ PCH ₂ PCH ₂ PCH ₂ ⁺
419.6		0.4	...	GCH ₂ OCH ₂ G
<u>430.9</u>	432	4.4	3.9	GCH ₂ PCH ₂ G
<u>449.9</u>		1.5	...	(HOCH ₂) ₂ PCH ₂ PCH ₂ PCH ₂ OH
480.1*	481	9.6	...	(HOCH ₂) ₂ PCH ₂ PCH ₂ P(CH ₂ OH) ₂
493.4*		1.8	...	GCH ₂ PCH ₂ G
510.3*		3.0	...	GCH ₂ PCH ₂ GCH ₂ ⁺
534*		...	0.7	GCH ₂ PCH ₂ GCH ₂ OH
<u>552*</u>		1.2	4.9	(CH ₂ ⁺)GCH ₂ P(–CH ₂ ⁺)CH ₂ GCH ₂ OH
<u>566.4*</u>	568	...	0.5	HOCH ₂ GCH ₂ P(–CH ₂ ⁺)CH ₂ GCH ₂ OH
<u>577.5*</u>		2	2.9	HOCH ₂ GCH ₂ P(–CH ₂ OH)CH ₂ GCH ₂ OH
599.1*	599	2	0.3	HOCH ₂ G(–CH ₂ ⁺)CH ₂ P(–CH ₂ OH)CH ₂ GCH ₂ OH
<u>607.2*</u>		4.2	5.7	GCH ₂ PCH ₂ GCH ₂ PCH ₂ ⁺
620*		3.7	0.3	or (HOCH ₂) ₂ PCH ₂ P(–CH ₂ G)CH ₂ PCH ₂ OH
<u>752.6</u>		1.6	1.5	(HOCH ₂) ₂ PCH ₂ P(–CH ₂ OCH ₂ G)CH ₂ P
769*		0.8	0.3	(HOCH ₂) ₂ PCH ₂ P(–CH ₂ OCH ₂ G)CH ₂ PCH ₂ ⁺
<u>782.8*</u>		0.9	1.3	GCH ₂ PCH ₂ GCH ₂ PCH ₂ G minus 1(–OH)
799*		0.5	...	GCH ₂ PCH ₂ GCH ₂ PCH ₂ G
815.3		0.8	1.1	GCH ₂ PCH ₂ GCH ₂ PCH ₂ GCH ₂ ⁺
888.9*	888.8	0.5	...	GCH ₂ PCH ₂ GCH ₂ PCH ₂ GCH ₂ PCH ₂ ⁺
928.4		...	1.0	GCH ₂ PCH ₂ GCH ₂ P(–CH ₂ G)CH ₂ G
<u>958.3*</u>		...	1.0	GCH ₂ PCH ₂ GCH ₂ PCH ₂ GCH ₂ G

*Peaks where G (gallic acid) is present.

Underlined are the peaks present as well in the oven dried specimens.

Underlined in bold are the peaks that are present in the oven dried specimens but not in the air dried ones.

Table 2 TMA results: average value of maximum MOE and temperature at maximum MOE at which full curing occurs for different proportions of PF/chestnut tannin in adhesive formulations

Phenol/chestnut tannin ratio	Average value of maximum MOE/MPa	Temperature at max MOE/°C
50:50	4109	170
45:55	4002	170–180
40:60	4135	185
35:65	3866	170–190
30:70	3264	180
20:80	3117	185–220
10:90	3162	200–230
0:100	2231	>240

Table 3 Laboratory particleboard internal bond (IB) strength results for resins with different relative proportions of phenol and chestnut tannin

Resins	pH	Board density/kg m ⁻³	Internal bond strength/MPa
45% phenol–55% tannin	11.02	688	0.58 ± 0.09
40% phenol–60% tannin	11.02	677	0.40 ± 0.04
30% phenol–70% tannin	11.02	681	0.35 ± 0.06
20% phenol–80% tannin	11.01	682	0.31 ± 0.05
European Norm requirement			≥0.35

limit for P2, indicating that such a formulation cannot be used industrially for P2 type panels because even small variations will push its internal bond strength below the standard requirements. However, all the panels in Table 3 pass the European Norm specification limit for P1 type panels, an encouraging result.

Conclusion

Hydrolysable tannins, e.g. chestnut tannin, appear to be able to substitute a high proportion of synthetic phenol in PF resins for wood particleboard.¹³C NMR and, in particular, MALDI–TOF spectrometry have determined that synthetic phenol and hydrolysable chestnut tannin do coreact with formaldehyde, forming methylene bridges linking phenol and the phenolic rings of the tannin. This was found to be remarkable for two reasons: (1) notwithstanding the relative low reactivity of the phenolic aromatic rings of the tannin these still managed to coreact with formaldehyde and to form tannin to phenol methylene bridges; and, (2) even more remarkable is that the hydrolysable tannin reacted through their *meta*- sites, supposedly less reactive, but as is demonstrated, these were the only tannin aromatic ring sites still available for reaction.

References

- ChemWindows. 1998. BioRad Laboratories, Sadtler Division, Philadelphia, PA, USA.
 European Norm EN 312. 1995. Wood particleboard – specifications.
 Fengel, D., and Wegener, G. 1984. Wood: chemistry, ultrastructure, reactions. Berlin: De Gruyter.

- Garnier, S., Huang, Z., and Pizzi, A. 2001. Commercial tannin adhesives-bonded particleboard IB forecasting by TMA bending. Holz Roh. Werkstoff. 59: 46–47.
 Kulvik, E. 1976. Chestnut wood tannin extract in plywood adhesives. Adhes. Age 19(3): 19–21.
 Laigle, Y., Kamoun, C., and Pizzi, A. 1998. Particleboard I.B. forecast by TMA bending in UF adhesives curing. Holz Roh. Werkstoff. 56(3): 154.
 Lecourt, M., Humphrey, P., and Pizzi, A. 2003. Comparison of TMA and ABES as forecasting systems of wood bonding effectiveness. Holz Roh. Werkstoff. 61(1): 75–76.
 Pasch, H., Pizzi, A., and Rode, K. 2001. MALDI–TOF mass spectrometry of polyflavonoid tannins. Polymer 42: 7531–7539.
 Pizzi, A. 1977. Hot-setting tannin–urea–formaldehyde exterior wood adhesives. Adhes. Age 20(12): 27–29.
 Pizzi, A. 1979. Phenol and tannin-based adhesive resins by reactions of coordinated metal ligands, Part 1: Phenolic chelates. J. Appl. Polym. Sci. 24: 1247–1257.
 Pizzi, A. (edited). 1983. Wood adhesives: chemistry and technology. New York: Marcel Dekker, 177–246.
 Pizzi, A. 1997. On the correlation of some theoretical and experimental parameters in polycondensation cross-linked networks. J. Appl. Polym. Sci. 63: 603–617.
 Pizzi, A. 1999. On the correlation equations of liquid and solid ¹³C NMR, TMA, T_g and network strength in polycondensation resins. J. Appl. Polym. Sci. 71(10): 1703–1709.
 Pizzi, A., Pasch, H., Rode, K., and Giovando, S. 2009. Polymer structure of commercial hydrolysable tannins by MALDI–TOF mass spectrometry. J. Appl. Polym. Sci. 113: 3847–3859.
 Pizzi, A., Probst, F., and Deglise, X. 1997. Molecular mechanics modelling of interfacial energy and flexibility. J. Adhes. Sci. Technol. 11(4): 573–590.
 Pizzi, A., and Scharfetter, H. 1978. The chemistry and development of tannin-based wood adhesives for exterior plywood. J. Appl. Polym. Sci. 22: 1745–1761.
 Zhao, C., Garnier, S., and Pizzi, A. 1998. Particleboard dry and wet IB forecasting by gel time and dry TMA bending in PF wood adhesives. Holz Roh. Werkstoff. 56: 402–403.

Une nouvelle recette de résines phénoliques à base de tanins de châtaignier.

Auteurs: S.SPINA, X.ZHOU, C.SEGOVIA, A.PIZZI, M.ROMAGNOLI, S.GIOVANDO, H.PASCH, K.RODE, L.DELMOTTE

J.Adh.Sci.Technol, (2012), DOI:10.1080/01694243.2012.697673

Jusqu'à maintenant le tanin de châtaignier, comme tous les tanins hydrolysables, n'était pas utilisé pour faire des résines avec les aldéhydes, comme le formaldéhyde, car sa réactivité s'avérait trop faible. Cela était dû au fait que le tanin était introduit en tant qu'additif final dans une résine déjà formulée et il lui était difficile de réagir sur un polymère phénolique relativement peu réactif.

Dans ce travail, nous avons essayé de synthétiser des résines phénoliques dans lesquelles les tanins hydrolysables étaient additionnés en remplacement partiel du phénol pour polymériser directement avec le formaldéhyde. On a pu substituer jusqu'à 80% du phénol et obtenir ainsi de nouvelles formulations de résines phénoliques de qualité supérieure dont les caractéristiques physiques et mécaniques sont tout à fait satisfaisantes.

En conclusion, cette étude montre qu'il est possible de synthétiser des résines tanin-phénol-formaldéhyde à partir du tanin hydrolysable de châtaignier. On pourrait même certainement envisager l'utilisation d'autres tanins hydrolysables dans de telles formulations. Ces résines sont plus écosoutenables et présentent des propriétés comparables à celles basées uniquement sur le mélange phénol-formol.

S.SPINA, X.ZHOU, C.SEGOVIA, A.PIZZI, M.ROMAGNOLI, S.GIOVANDO, H.PASCH, K.RODE, L.DELMOTTE, Phenolic resin adhesives based on chestnut hydrolysable tanins, *J.Adh.Sci.Technol*, (2012), DOI:10.1080/01694243.2012.697673

This article was downloaded by: [A. Pizzi]

On: 22 August 2012, At: 02:24

Publisher: Taylor & Francis

Informa Ltd Registered in England and Wales Registered Number: 1072954 Registered office: Mortimer House, 37-41 Mortimer Street, London W1T 3JH, UK



Journal of Adhesion Science and Technology

Publication details, including instructions for authors and subscription information:

<http://www.tandfonline.com/loi/tast20>

Phenolic resin adhesives based on chestnut (*Castanea sativa*) hydrolysable tannins

S. Spina^{a,b}, X. Zhou^b, C. Segovia^b, A. Pizzi^b, M. Romagnoli^a, S. Giovando^c, H. Pasch^d, K. Rode^e & L. Delmotte^f

^a DAF, Faculty of Agriculture, via San Camillo de Lellis, University of Tuscia, 01100, Viterbo, Italy

^b ENSTIB-LERMAB, University Henri Poincaré - Nancy 1, 27 rue Philippe Seguin, BP 1041, Epinal, 88051, France

^c CRCF (SILVA Team), via Torre 7, 12080 San Michele Mondovì, Italy

^d Department of Chemistry and Polymer Science, University of Stellenbosch, Private Bag X1, 7602 Matieland, Stellenbosch, South Africa

^e Deutsches Kunststoff-Institut, Abteilung Analytik, Schlossgartenstr. 6, 64289, Darmstadt, Germany

^f IS2M, Université de Haute Alsace, CNRS LRC 7228, 15 rue Jean Starcky, B.P. 2488, 68057 Mulhouse, France

Version of record first published: 10 Aug 2012

To cite this article: S. Spina, X. Zhou, C. Segovia, A. Pizzi, M. Romagnoli, S. Giovando, H. Pasch, K. Rode & L. Delmotte (2012): Phenolic resin adhesives based on chestnut (*Castanea sativa*) hydrolysable tannins, *Journal of Adhesion Science and Technology*, DOI:10.1080/01694243.2012.697673

To link to this article: <http://dx.doi.org/10.1080/01694243.2012.697673>



PLEASE SCROLL DOWN FOR ARTICLE

Full terms and conditions of use: <http://www.tandfonline.com/page/terms-and-conditions>

This article may be used for research, teaching, and private study purposes. Any substantial or systematic reproduction, redistribution, reselling, loan, sub-licensing, systematic supply, or distribution in any form to anyone is expressly forbidden.

The publisher does not give any warranty express or implied or make any representation that the contents will be complete or accurate or up to date. The accuracy of any instructions, formulae, and drug doses should be independently verified with primary sources. The publisher shall not be liable for any loss, actions, claims, proceedings, demand, or costs or damages whatsoever or howsoever caused arising directly or indirectly in connection with or arising out of the use of this material.

Phenolic resin adhesives based on chestnut (*Castanea sativa*) hydrolysable tannins

S. Spina^{a,b}, X. Zhou^b, C. Segovia^b, A. Pizzi^{b,*}, M. Romagnoli^a, S. Giovando^c, H. Pasch^d,
K. Rode^e and L. Delmotte^f

^aDAF, Faculty of Agriculture, via San Camillo de Lellis, University of Tuscia, 01100 Viterbo, Italy; ^bENSTIB-LERMAB, University Henri Poincaré – Nancy 1, 27 rue Philippe Seguin, BP 1041, Epinal 88051, France; ^cCRCF (SILVA Team), via Torre 7, 12080 San Michele Mondovì, Italy; ^dDepartment of Chemistry and Polymer Science, University of Stellenbosch, Private Bag XI, 7602 Matieland, Stellenbosch, South Africa; ^eDeutsches Kunststoff-Institut, Abteilung Analytik, Schlossgartenstr. 6, 64289 Darmstadt, Germany; ^fIS2M, Université de Haute Alsace, CNRS LRC 7228, 15 rue Jean Starcky, B.P. 2488, 68057 Mulhouse, France

(Received 1 September 2010; final version received 17 August 2011; accepted 1 March 2012)

Chestnut hydrolysable tannins are phenolic materials that have been considered too unreactive to compete in the phenolic resin adhesives market for exterior boards for the building industry. However, an article in 1973 describing 3 years industrial application of chestnut hydrolysable tannins during the first oil crisis indicated that this was not the case. We have extended this old work by using superior phenolic resins formulations and producing phenol–formaldehyde–chestnut tannin adhesives where a substitution of up to 80% of the phenol is possible with remarkably good results. The reactions involved were clarified by ¹³C NMR and MALDI-TOF mass spectrometry.

Keywords: chestnut tannin; hydrolysable tannins; wood adhesives; wood panel adhesives; phenolic resins

1. Introduction

In 1973, as a consequence of the first oil crisis, Norsechem, a Norwegian paint group subsidiary in Malaysia that produced phenol–formaldehyde (PF) resins for Southeast Asia plywood manufacturers, was forced to implement a technological change that was utilized for 3 years in industrial production [1]. This technology consisted of substituting 33% by weight of phenol with chestnut tannin extract in the PF resin during its preparation. Up to 50% substitution in the laboratory was claimed but no glue-mix or other information was given [1]. The motive of this was purely economical, as phenol prices had skyrocketed and the cost of chestnut tannin extract was much lower. In the only written reference that exists relative to this development [1], results and basic material proportions are reported, but resin formulations are not disclosed.

The use of chestnut tannin extract in this context is particularly intriguing, as this is the most expensive of all the natural tanning agents for leather due to the very light coloured leather it yields. Its use is even more intriguing if one considers: (1) the development of cheaper and more abundant condensed or flavonoid tannin adhesives, which are far more

*Corresponding author. Email: antonio.pizzi@enstib.uhp-nancy.fr

reactive than hydrolysable tannins, and in extended industrial use at the same time [2–5] and (2) the low reactivity of the phenolic rings in hydrolysable tannins and relatively high proportion of carbohydrates that are linked to their phenolic part and are undissociable from it.

Hydrolysable commercial tannin extracts are mixtures of esters of a sugar, mainly glucose, with simple phenols such as gallic and digallic acids, and also with more complex structures containing ellagic acid [6–8] (Scheme 1).

For many decades hydrolysable tannins were considered to be mainly formed of phenolic esters of simple sugars such as glucose. Their alleged lack of a polymeric structure, although it could still result in complex structures, caused them to be considered unsuitable for adhesives [5]. Once the first oil crisis had passed and the price of phenol became affordable again, the PF-chestnut tannin adhesive production was stopped, and interest in this resin had waned by 1977. Recently, however, their extensive polymeric structure based on pentagalloyl glucose repeat units has been clearly determined [8]. Thus, in a situation where other types of tannins, e.g. condensed tannins, are relatively scarce due to the growing interest in environment-friendly adhesives, revival of the PF-chestnut tannin extract technology is a useful exercise, given the abundance of chestnut trees in Europe.

In this study we have re-examined the PF-chestnut tannin extract technology by: (1) developing and optimizing the resin formulation and synthesis using modern PF resins formulations; (2) drastically and progressively decreasing the relative proportions of phenol and increasing those of chestnut tannin extract to obtain even higher proportions of natural material; (3) determining if coreaction of phenol and phenolic tannin occurs or not. This is a crucial question as (a) the hydrolysable tannin aromatic rings (both monomer as well as bound in natural oligomers) are less reactive than the reactive sites of phenol and (b) only the much less reactive *meta*-sites are still free in the main phenolic unit of chestnut tannin, namely gallic acid, of structure

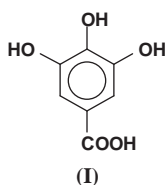

and (4) applying for the first time such improved and optimized adhesives to wood particleboards, more complex but much faster pressing panels than plywood for which these adhesives were originally developed.

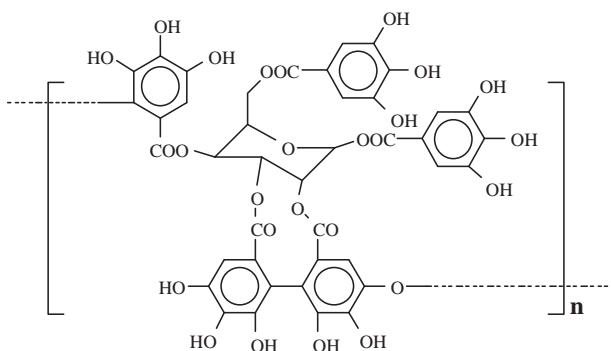

Scheme 1.

2. Experimental

2.1. Resin preparation

Commercial chestnut (*Castanea sativa*) wood tannin extract spray-dried powder obtained from SILVA Chimica, S. Michele Mondovi, Italy was used for the purpose. The resins based on PF–chestnut tannin extract were prepared according to the following procedure:

Eighty-five grams chestnut tannin extract and 85 g 90% phenol were dissolved in a solution of water–methanol (62.7 g water, 9.6 g methanol) to which were then added 95.5 g 96% paraformaldehyde powder (Degussa N, Düsseldorf, Germany) premixed with 4 g water. The reaction mixture was first heated at 40 °C for 30 min, under continuous mechanical stirring in a glass reactor equipped with a reflux condenser. The mixture was then heated until the temperature reached 94 °C, and then 45.2 g of 30% aqueous NaOH solution was added in four equal lots at intervals of 15 min. After the addition of the last lot of NaOH solution (45 min from the start of NaOH addition) the reaction mixture was heated for additional 15 min to reach a total of 1 h reaction time. After a further 15-min reaction, the mixture was cooled and stored. The resin obtained had viscosity at 25 °C of 550–600 cP, solids content of 61% and pH of 8.6 which was then adjusted to pH 11 by addition of 18.4 g 30% NaOH aqueous solution. This pH adjustment caused a decrease in solids content to 55.8% and of viscosity to 375–400 cP.

Resins in which the effective weight proportions of phenol:chestnut tannin extract were 50:50, 45:55, 40:60, 30:70, 20:80, 10:90 and 0:100 were prepared and tested, while the relative proportions of formaldehyde, water, methanol and sodium hydroxide were maintained constant for all resins. The curves obtained yielded maximum modulus of elasticity (MOE) values by thermomechanical analysis (TMA) analysis.

2.2. MALDI-TOF sample preparation

The resin was dried in two different ways. For the first sample, water/methanol was evaporated under vacuum at 40 °C on a rotary evaporator, to minimize curing and to be able to better examine the resin oligomers distribution. The second sample was allowed to dry in the oven at 105 °C for 16 h and then ground to fine powder to study oligomers distribution once the resin had cured.

These resin samples were dissolved in acetone/water (4 mg/mL, 50/50 acetone/water by volume). The sample solutions were mixed with an acetone solution (10 mg/mL in acetone) of the matrix. As the matrix 2,5-dihydroxy benzoic acid was used. For the enhancement of ion formation, NaCl was added to the matrix (10 mg/mL in water). The solutions of the sample and the matrix were mixed in the proportions three parts matrix solution +3 parts polymer solution +1 part NaCl solution. A small amount (0.5–1 μ L) of the resulting solution mix was placed on the MALDI target. After evaporation of the solvent the MALDI target was introduced into the spectrometer. From each peak value in the resulting positive mode spectrum 23 Da of the Na⁺ of the matrix must be subtracted to obtain the molecular weight of the chemical species of the peak.

2.3. MALDI-TOF-MS analysis

The spectra were recorded on a KRATOS Kompact MALDI AXIMA TOF 2 instrument. The irradiation source was a pulsed nitrogen laser with a wavelength of 337 nm. The time period of a laser pulse was 3 ns. The measurements were carried out using the following conditions: polarity-positive, flight path-linear, mass-high (20 kV acceleration voltage), 100–150 pulses

per spectrum. The delayed extraction technique was used by applying delay times of 200–800 ns.

2.4. CP-MAS ^{13}C NMR

Solid state CP-MAS (cross-polarization/magic angle spinning) ^{13}C NMR spectra of the oven-dried resin were recorded on a Bruker MSL 300 spectrometer at a frequency of 75.47 MHz. Chemical shifts were calculated relative to tetramethyl silane (TMS). The rotor was spun at 4 kHz on a double-bearing 7 mm Bruker probe. The spectra were acquired with 5 s recycle delays, a 90° pulse of 5 μs and a contact time of 1 ms. The number of transients was 3000.

2.5. Thermomechanical analysis

The hardening reaction of different resin systems was evaluated by TMA, by following the progressive hardening of a resin-bonded wood joint as a function of temperature. All experiments were conducted under the same conditions: heating rate = $10^\circ\text{C}/\text{min}$, 30 mg of resin system and temperature range of $25\text{--}250^\circ\text{C}$. Thermomechanical analyser used was a TMA40 instrument from Mettler Toledo. The software used for data treatment was STARE. Deflection curves that permit MOE determination were obtained by three-point bending of the joint formed by two beech wood veneers, dimensions $21\text{ mm} \times 6\text{ mm} \times 0.6\text{ mm}$ each, between which was inserted the liquid resin. The MOE of resin-bonded wood joints gives an indication of the performance of the adhesive.

The maximum MOE value and its increase as a function of time or temperature for resin bonded wood joints gave a good indication of the possible end performance of the adhesive system tested. Values in excess or close to 4000 MPa indicated the applicability of the resins for the manufacture of wood particleboard.

2.6. Wood particleboard preparation and testing

One-layer laboratory particleboards of dimensions $350\text{ mm} \times 300\text{ mm} \times 14\text{ mm}$ were prepared using a wood mixture of core particles of beech (*Fagus sylvatica*) and Norway spruce (*Picea abies*) at $28\text{ kg}/\text{cm}^2$ maximum pressure and 195°C press temperature. The resin solids content was maintained at 10% of the total mix. The total press time was kept at 7.5 min. All particleboards were tested for internal bond (IB) strength on an Instron 3369 test machine (High Wycombe, UK). First a 45/55 PF/chestnut adhesive was formulated to prepare 10 laboratory panels. Afterwards triplicate panels with adhesive formulations containing a decreasing proportion of phenol were tested. For accelerated ageing tests, specimens were boiled in water for 2 h, dried at 103°C for 16 h and tested for residual IB strength using an Instron 3369 test machine (High Wycombe, UK).

3. Results and discussion

The CP-MAS ^{13}C NMR spectrum (Figure 1) of the oven-dried 45/55 PF/chestnut tannin extract resin indicated the following: the band at 151 ppm belonging to the aromatic carbon linked to a phenolic $-\text{OH}$, for both the tannin and the PF resin. The very pronounced 130 ppm band belongs to all the unreacted *meta*-sites and reacted *ortho* and *para* sites on the aromatic phenolic rings. The bands at 120 and 115 ppm, which are characteristic of still free, unreacted *ortho* and *para* sites, respectively, do not appear at all, indicating that these sites

had completely reacted. The large band at 70 ppm is given by the superposition of the carbohydrate part of the chestnut extract and of the methylol groups ($-\text{CH}_2\text{OH}$) present on the reacted *ortho* and *para* sites of both phenol and the phenolic fraction of the tannin. Finally, the band centered at 34 ppm is composed of a series of superimposed bands one of which is clearly visible as a separate peak at 37.3 ppm. This one corresponds to methylene bridges linking gallic acid ring sites (theoretically calculated values for these methylene bridges is 37.33 ppm [9]) and is indicated with an arrow in the spectrum in Figure 1. The band at 40 ppm belongs to the *para-para* methylene bridges between phenols of the synthetic PF component of the hardened network. The band at 34 ppm belongs to *ortho-para* PF methylene bridges that are in greater proportion. These methylene bridges are between phenol and phenol (40 and 34 ppm), phenol and tannin (37.3 ppm) and tannin and tannin (37.3 ppm). Thus, given the broadness of these bands, the phenol and the phenolic fraction of the tannin appear to have coreacted, confirming the reason why such a resin had hardened.

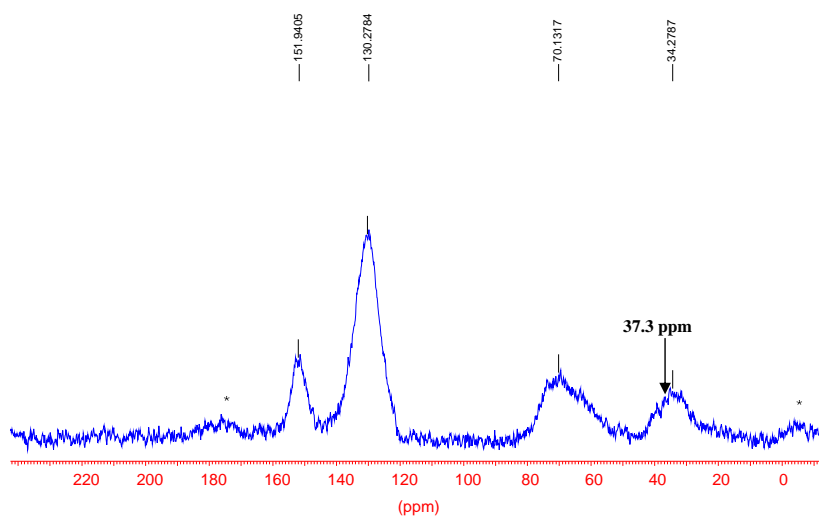

Figure 1. CP-MAS ^{13}C NMR spectrum of oven-dried 45/55 PF/chestnut tannin adhesive. Band at 37.3 ppm corresponds to calculated NMR shift for methylene bridges linking two gallic acid aromatic rings.

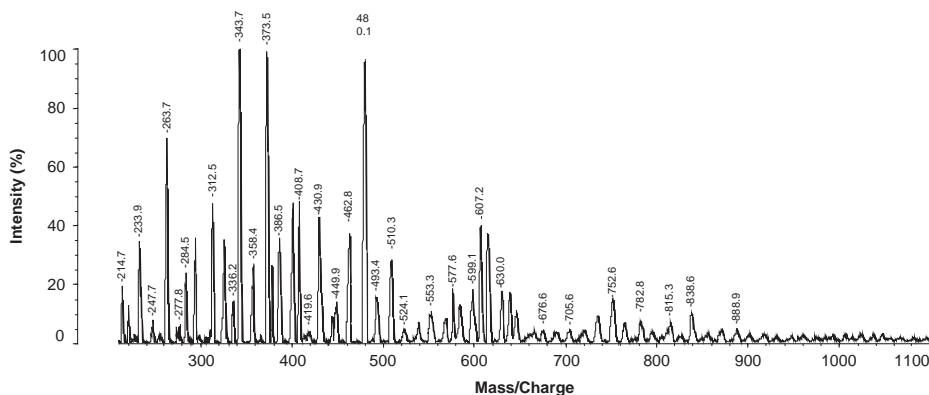

Figure 2. MALDI-TOF spectrum of air-dried 45/55 PF/chestnut tannin adhesive.

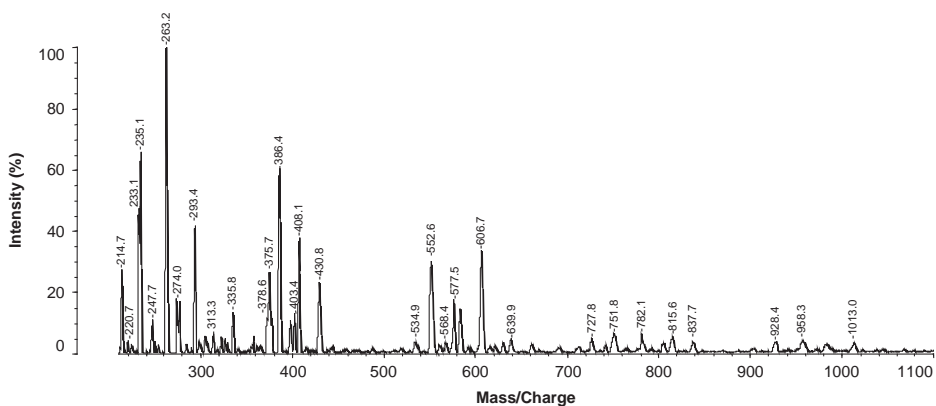

Figure 3. MALDI-TOF spectrum of oven-dried 45/55 PF/chestnut tannin adhesive.

Further and definitive confirmation of coreaction of tannin and phenol is obtained by the MALDI-TOF spectrum of the same resin. MALDI-TOF analysis can be performed in either positive or negative ion modes [8]. In the case of hydrolysable tannins the positive mode spectrum shows what happens to the phenolic component of the material while negative ion mode analysis shows what happens to the polymeric carbohydrates of the system [8]. Positive mode MALDI-TOF analysis is commonly performed, as is the case in this article, while negative mode is used rarely. Thus, in Figures 2 and 3 and Table 1 are shown the oligomers that are formed from the phenolic component of the phenol–tannin–formaldehyde resin during the preparation and hardening of the resin. Table 1 also shows the relative percentages of an air-dried resin (not cured but simply dried after preparation) and of an oven-cured resin. The first conclusion that can be drawn is that a number of coreacted phenol–tannin oligomers are formed, confirming the NMR result (Figure 1). The tannin contribution is indicated as ‘G’ (for gallic acid) this being calculated as gallic acid equivalents (Table 1). Thus, definitely belonging to co-reacted mixed species are the series of peaks at 299, 312, 406, 480, 493, 510, 534, 552, 566, 577, 599, 607, 620, 769, 782, 799, 888 and 958 Da, constituting 66% of the total number of species of the polymer and 50% of the total mass of the polymer. Mixed species may also contribute to the peaks at 327 and 403 Da. The rest of the peaks belong to pure PF oligomers.

The first point of interest of all these observations is that a species such as gallic acid (structure I), which has both sterically hindered sites and those in *meta* position to some of the phenolic –OH groups, is rather reactive and forms through these *meta* sites methylene bridges with the *ortho* and *para* sites of the synthetic phenol. This indicates that hydrolysable chestnut tannin phenolic aromatic rings are far more reactive than originally thought [4].

Table 2 shows the maximum MOE values obtained during TMA curing of the PF/chestnut extract resins. It can be observed that the maximum MOE value obtained is 4135 MPa for resins in which the PF/chestnut extract weight proportion is 40/60, which strongly demonstrates their capability for use for the manufacture of particleboard panels of good quality. Table 2 also reported the average values of maximum MOE obtained by TMA for resins in which the relative proportions of phenol to chestnut varied during the preparation of the resin. Thus, the average maximum MOE value, which is directly correlatable to the IB strength of wood particleboard panels [10,11] varied only little when chestnut tannin was up to 60% of the total material and decreased with greater proportions of chestnut tannin in the resin. The

Table 1. MALDI-TOF spectrometry peaks, corresponding oligomers formed, and their relative percentage proportions for a 45/55 PF/chestnut tannin resin reacted for 68 min.

M + Na ⁺ (Expl.)	M + Na ⁺ (calc.)	Relative proportion (%)		Oligomer type
		Air dried	Oven dried	
<u>233.9–235</u>	236	3.5	18.7	PCH ₂ PCH ₂ ⁺
<u>263.7</u>	264	7.1	16.3	HOCH ₂ PCH ₂ PCH ₂ ⁺
<u>277.8</u>	277	0.7	2.8	HOCH ₂ PCH ₂ P(CH ₂ ⁺) ₂
299 ^a		3.8	6.8	GCH ₂ P
<u>312.5^a</u>		4.7	1.1	GCH ₂ PCH ₂ ⁺
327 ^a		3.5	0.8	GCH ₂ PCH ₂ OH
				or
329				GCH ₂ PCH ₂ P
343.7		9.9	—	PCH ₂ PCH ₂ P
358.4	359	2.8	2.3	PCH ₂ PCH ₂ PCH ₂ ⁺
<u>373.5</u>	373.7	9.8	2.8	PCH ₂ PCH ₂ PCH ₂ OH
<u>375^a</u>	375	2.7	4.4	HOCH ₂ PCH ₂ PCH ₂ PCH ₂ ⁺
<u>386.5</u>	387	3.6	9.9	GCH ₂ G
<u>403.5^a</u>	403	4.7	2.4	HOCH ₂ PCH ₂ PCH ₂ P(CH ₂ ⁺) ₂
				(HOCH ₂) ₂ PCH ₂ PCH ₂ PCH ₂ ⁺
				or
<u>406.5^a</u>		4.8	6.3	GCH ₂ OCH ₂ G
419.6		0.4	—	GCH ₂ PCH ₂ G
<u>430.9</u>	432	4.4	3.9	(HOCH ₂) ₂ PCH ₂ PCH ₂ PCH ₂ OH
449.9		1.5	—	(HOCH ₂) ₂ PCH ₂ P(–CH ₂ ⁺)CH ₂ PCH ₂ OH
480.1 ^a	481	9.6	—	(HOCH ₂) ₂ PCH ₂ PCH ₂ P(CH ₂ OH) ₂
493.4 ^a		1.8	—	GCH ₂ PCH ₂ G
510.3 ^a		3.0	—	GCH ₂ PCH ₂ GCH ₂ ⁺
<u>534^a</u>		—	0.7	GCH ₂ PCH ₂ GCH ₂ OH
<u>552^a</u>		1.2	4.9	(CH ₂ ⁺)GCH ₂ P(–CH ₂ ⁺)CH ₂ GCH ₂ OH
<u>566.4^a</u>	568	—	0.5	HOCH ₂ GCH ₂ P(–CH ₂ ⁺)CH ₂ GCH ₂ OH
<u>577.5^a</u>		2	2.9	HOCH ₂ GCH ₂ P(–CH ₂ OH)CH ₂ GCH ₂ OH
599.1 ^a	599	2	0.3	HOCH ₂ G(–CH ₂ ⁺)CH ₂ P(–CH ₂ OH)CH ₂ GCH ₂ OH
<u>607.2^a</u>		4.2	5.7	GCH ₂ PCH ₂ GCH ₂ PCH ₂ ⁺
				or
620 ^a		3.7	0.3	(HOCH ₂) ₂ PCH ₂ P(–CH ₂ G)CH ₂ PCH ₂ OH
<u>752.6</u>		1.6	1.5	(HOCH ₂) ₂ PCH ₂ P(–CH ₂ OCH ₂ G)CH ₂ P
769 ^a		0.8	0.3	(HOCH ₂) ₂ PCH ₂ P(–CH ₂ OCH ₂ G)CH ₂ PCH ₂ ⁺
<u>782.8^a</u>		0.9	1.3	GCH ₂ PCH ₂ GCH ₂ PCH ₂ G–I(–OH)
799 ^a		0.5	—	GCH ₂ PCH ₂ GCH ₂ PCH ₂ G
				or
815.3		0.8	1.1	GCH ₂ PCH ₂ GCH ₂ PCH ₂ GCH ₂ ⁺
888.9 ^a	888.8	0.5	—	GCH ₂ PCH ₂ GCH ₂ PCH ₂ GCH ₂ PCH ₂
<u>928.4</u>		—	1.0	GCH ₂ PCH ₂ GCH ₂ P(–CH ₂ G)CH ₂ G
<u>958.3^a</u>		—	1.0	GCH ₂ PCH ₂ GCH ₂ PCH ₂ GCH ₂ G

^aAre the peaks where G (gallic acid) is present.

Underlined are the peaks present as well in the oven-dried specimens.

Underlined in blue are the peaks that are present in the oven-dried specimens but not in the air-dried ones.

maximum value of the MOE starts to be slightly lower, but still very good for the 35/65 adhesive formulation but starts to decrease rather markedly for the 30/70 adhesive formulation and for formulations with even higher proportions of hydrolysable chestnut tannin. The results for the experimental laboratory particleboards (Tables 3 and 4) support the TMA

Table 2. TMA results: average value of maximum MOE and temperature at maximum MOE at which full curing occurs for different proportions of PF/chestnut tannin in the adhesive formulations.

Phenol/chestnut tannin ratio	Average value of maximum MOE (MPa)	Temperature at maximum MOE (°C)
50/50	4109	170
45/55	4002	170–180
40/60	4135	185
35/65	3866	170–190
30/70	3264	180
20/80	3117	185–220
10/90	3162	200–230
0/100	2231	>240

Table 3. Average board density and IB strength for a series of 10 wood particleboard panels prepared with 10% solid resin content of a 45/55 PF/chestnut tannin extract adhesive.

Average board density (kg/m ³)	Average IB strength (MPa)
681	0.72
705	0.60
683	0.69
689	0.60
679	0.56
697	0.52
695	0.51
695	0.64
683	0.53
681	0.44
Average 688+9	0.58+0.09

Table 4. Laboratory particleboard IB strength results for resins with different relative proportions of phenol and chestnut tannin.

Resins	pH	Board density (kg/m ³)	IB strength (MPa)
45% phenol–55% tannin	11.02	688	0.58±0.09
40% phenol–60% tannin	11.02	677	0.40±0.04
30% phenol–70% tannin	11.02	681	0.35±0.06
20% phenol–80% tannin	11.01	682	0.31±0.05
European norm requirement		670–699	>0.35

results. Thus, wood particleboard prepared with a 45/55 PF/chestnut tannin extract adhesive yielded average dry IB strength of 0.58 MPa for an average density of 688 kg/m³ (Table 3). This is considerably above the 0.35 MPa required by international wood particleboard standards for the same type. The 40/60 adhesive formulation also produced panels that satisfied well the dry IB strength requirements of relevant the European Norm [12]. However, the 30/70 phenol/tannin adhesive formulation gave results that were just close to the European Norm limit, indicating that such a formulation cannot be used industrially because even small variations will push its IB strength below the standard requirements. Thus the 40/60 and

perhaps 35/65 phenol/tannin adhesive formulations can produce boards that meet dry IB strength standards.

4. Conclusion

Hydrolysable tannins, e.g. chestnut tannin, appear to be able to substitute a high proportion of synthetic phenol in PF resins for wood particleboard. ^{13}C NMR and, in particular, MALDI-TOF spectrometry have determined that synthetic phenol and hydrolysable chestnut tannin do co-react with formaldehyde, forming methylene bridges linking phenol and the phenolic rings of the tannin. This was found to be remarkable for two reasons: (1) notwithstanding the relative low reactivity of the phenolic aromatic rings of the tannin these still managed to co-react with formaldehyde and to form tannin-to-phenol methylene bridges and (2) even more remarkable is that the hydrolysable tannin reacted through their *meta*-sites, supposedly less reactive, but as we determined, these were the only tannin aromatic ring sites still available for reaction.

References

- [1] Kulvik E. Chestnut wood tannin extracts in plywood adhesives. *Adhesives Age*. 1976;19(3):19–21.
- [2] Pizzi A, Scharfetter H. The chemistry and development of tannin-based wood adhesives for exterior plywood. *Journal of Applied Polymer Science*. 1978;22:1745–61.
- [3] Pizzi A. Phenol and tannin-based adhesive resins by reactions of coordinated metal ligands, Part 1: phenolic chelates. *Journal of Applied Polymer Science*. 1979;24:1247–57.
- [4] Pizzi A. Hot-setting tannin-urea-formaldehyde exterior wood adhesives. *Adhesives Age*. 1977;20(12):27–9.
- [5] Pizzi A. Tannin-based wood adhesives. In: Pizzi A, editor. *Wood adhesives: chemistry and technology*. New York, (NY): Marcel Dekker; 1983. 177–246.
- [6] Fengel D, Wegener G. *Wood: chemistry, ultrastructure, reactions*. Berlin: De Gruyter; 1984.
- [7] Pasch H, Pizzi A, Rode K. MALDI-TOF mass spectrometry of polyflavonoid tannins. *Polymer*. 2001;42:7531–9.
- [8] Pizzi A, Pasch H, Rode K, Giovando S. Polymer structure of commercial hydrolysable tannins by MALDI-TOF mass spectrometry. *Journal of Applied Polymer Science*. 2009;113:3847–59.
- [9] ChemWindows. BioRad laboratories. Philadelphia, PA: Sadtler Division; 1998.
- [10] Zhao C, Garnier S, Pizzi A. Particleboard dry and wet IB forecasting by gel time and dry TMA bending in PF wood adhesives. *Holz Roh Werkstoff*. 1998;56:402–3.
- [11] Garnier S, Huang Z, Pizzi A. Commercial tannin adhesives-bonded particleboard IB forecasting by TMA bending. *Holz Roh Werkstoff*. 2001;59:46–7.
- [12] European Norm EN 312. *Wood particleboard – specifications* 1995.

Mousses de tanins écosoutenables.

Mousses à base de tanins, sans formaldéhyde.

Auteurs: M.C.BASSO, V.FIERRO, S.GIOVANDO, A.PIZZI, A.CELZARD

Patent application number (Italy): TO2011A000656 (déposé le 21-07-2011), étendu international PCT le 18/07/2012 avec n. PCT/EP2012/003031

Cette invention se réfère aux matériaux expansés à structure rigide ou solide à base de tanins condensés.

La demande de brevet qui décrit une manière de produire des mousses à base de tanins condensés, sans utiliser de formaldéhyde dans la composition, a été déposée pendant le travail de thèse. Le formaldéhyde a été substitué par de l'alcool furfurylique, pour sa capacité à copolymériser avec le tanin selon une catalyse acide.

L'invention permet d'éliminer le seul produit très polluant et potentiellement cancérigène qui reste dans les mousses aux tanins préparées jusqu'à maintenant. En effet, au niveau national, à partir de janvier 2012 et comme résultat du PNSE2 (Plan National Santé et Environnement 2), un étiquetage obligatoire relatif en particulier aux émissions des produits de construction, parmi lesquels se trouvent les produits d'isolation, devra être mis en place.

La réglementation met l'accent sur les émissions de formaldéhyde puisqu'au-dessus de 0.1 mg/m³ dans l'air, cette substance entraîne des symptômes tels que des irritations et des inflammations des yeux, des voies respiratoires et de la peau, des effets neurologiques (tels que maux de tête, vertiges, fatigue) et joue un rôle capital dans le développement des allergies et de l'asthme infantile. Des initiatives internationales similaires afin d'améliorer la qualité de l'air des bâtiments et de nouvelles restrictions sont envisageables étant donné que le formaldéhyde a été classé comme cancérigène suspecté par l'UE et comme

cancérogène certain par le CIRC (Centre International de Recherche sur le Cancer, dépendant de l'OMS).

Les matériaux proposés par la présente invention sont absolument exempts de ce polluant dans leur composition. D'autre part, ils sont fabriqués à partir de matières premières renouvelables et présentent les mêmes avantages que les mousses classiques. Ils peuvent être utilisés comme matériaux d'isolation thermique combinant une extrême légèreté, une résistance mécanique au moins égale à celle de toute autre mousse commerciale d'origine pétrochimique, un prix de revient inférieur, une infusibilité et une complète ininflammabilité ainsi qu'une conductivité thermique exceptionnellement basse. Toutes ces qualités font de ces nouveaux matériaux des concurrents sérieux, écologiques et biosourcés, des isolants thermiques actuels pour le bâtiment.

Une mousse rigide, insoluble et infusible, est préparée à partir d'un mélange de tanin majoritairement de type prorobinétinidine et/ou profisétinidine (ex : tanins de mimosa et de quebracho), d'alcool furfurylique et d'un agent moussant. Dans les mousses connues jusqu'à présent, on utilisait des quantités relativement importantes de formaldéhyde. Dans la présente invention, le formaldéhyde, aujourd'hui considéré comme produit cancérogène, est exclu et le procédé de préparation est donc différent.

La mousse ainsi obtenue est rigide et peu friable. Elle ne brûle pas mais se consume lentement si une grande quantité de chaleur est apportée. Elle est auto-extinguible et elle est aussi isolante thermiquement que les mousses qui contiennent du formaldéhyde.

Le travail rapporté dans ce brevet ouvre de nouvelles perspectives aux producteurs de mousses. En effet de grandes compagnies au niveau mondial sont très intéressées par ces produits d'un point de vue commercial.

La compagnie Silvateam, qui produit des tanins, et qui est copropriétaire du brevet avec l'Université de Lorraine, a d'ailleurs étendu le brevet au niveau mondial PCT.

M.C.BASSO, V.FIERRO, S.GIOVANDO, A.PIZZI, A.CELZARD, Composition for manufacturing a tanin-based foam material, foam material obtainable from it, and manufacturing process thereof, Patent application number (Italy): TO2011A000656 (21-07-2011), extended international PCT the 18/07/2012 with n. PCT/EP2012/003031.



- (51) **International Patent Classification:**
C08G 8/34 (2006.01) *C08J 9/14* (2006.01)
C08J 9/00 (2006.01)
- (21) **International Application Number:**
PCT/EP2012/003031
- (22) **International Filing Date:**
18 July 2012 (18.07.2012)
- (25) **Filing Language:** English
- (26) **Publication Language:** English
- (30) **Priority Data:**
TO2011A000656 21 July 2011 (21.07.2011) IT
- (71) **Applicants (for all designated States except US):** SIL-
VACHIMICA S.R.L. [IT/IT]; Via Torre 7, I-12080 San
Michele Mondovì (IT). UNIVERSITE' DE LORRAINE
- INSTITUT ENSTIB-LERMAB [FR/FR]; 27, rue Phil-
ippe Séguin, BP 1041, F-88051 Epinal Cedex 9 (FR).
- (72) **Inventors; and**
- (75) **Inventors/Applicants (for US only):** PIZZI, Antonio (84) **Designated States (unless otherwise indicated, for every
kind of regional protection available):** ARIPO (BW, GH,
BASSO, Maria, Cécilia [—/FR]; 32, rue Louis Blériot, F-
88000 Epinal (FR). CELZARD, Alain [—/FR]; 19, rue de
Laufromont, F-88000 Epinal (FR). FIERRO, Vanessa
[—/FR]; 19, rue de Laufromont, F-88000 Epinal (FR).
GIOVANDO, Samuele [—/IT]; Località Bussia, 122, I-
12065 Monforte d'Alba (CN) (IT).
- (74) **Agent:** CIAN, Paolo; c/o Sacconey & Cian, Corso Vit-
torio Emanuele II, 14, I-10123 Torino (IT).
- (81) **Designated States (unless otherwise indicated, for every
kind of national protection available):** AE, AG, AL, AM,
AO, AT, AU, AZ, BA, BB, BG, BH, BR, BW, BY, BZ,
CA, CH, CL, CN, CO, CR, CU, CZ, DE, DK, DM, DO,
DZ, EC, EE, EG, ES, FI, GB, GD, GE, GH, GM, GT, HN,
HR, HU, ID, IL, IN, IS, JP, KE, KG, KM, KN, KP, KR,
KZ, LA, LC, LK, LR, LS, LT, LU, LY, MA, MD, ME,
MG, MK, MN, MW, MX, MY, MZ, NA, NG, NI, NO, NZ,
OM, PE, PG, PH, PL, PT, QA, RO, RS, RU, RW, SC, SD,
SE, SG, SK, SL, SM, ST, SV, SY, TH, TJ, TM, TN, TR,
TT, TZ, UA, UG, US, UZ, VC, VN, ZA, ZM, ZW.

[Continued on next page]

- (54) **Title:** COMPOSITION FOR MANUFACTURING A TANNIN-BASED FOAM MATERIAL, FOAM MATERIAL OBTAIN-
ABLE FROM IT, AND MANUFACTURING PROCESS THEREOF

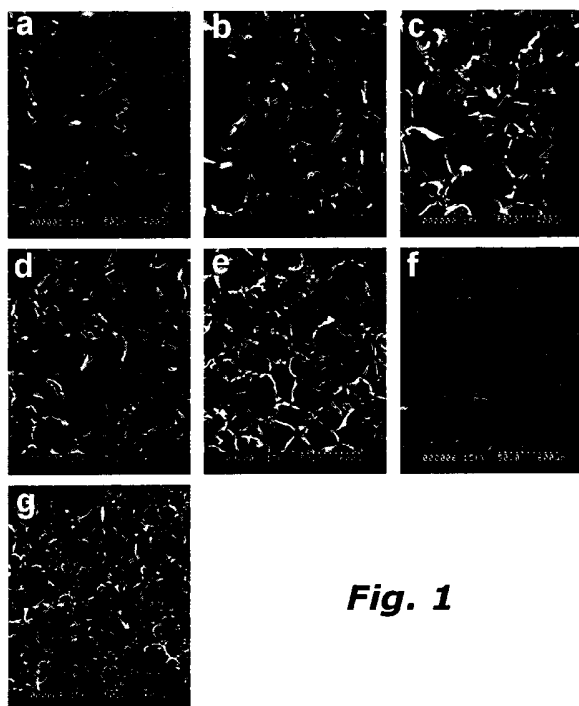

Fig. 1

(57) **Abstract:** A composition for manufacturing a foam material based on flavonoid tannins, includes a flavonoid tannin powder mainly of the prorobeneditinidin and/or the profisetinidin type, according to an amount in weight in the range between 40% and 45% of the composition, furfuryl alcohol, a blowing agent, and a catalyst. The composition is totally formaldehyde-free, and contains an amount of furfuryl alcohol greater than 20% in weight of the composition. The composition makes possible to obtain foam materials of high characteristics and low cost, that can typically be used in the fields of building and in the automotive industry and in the vehicles in general.

GM, KE, LR, LS, MW, MZ, NA, RW, SD, SL, SZ, TZ, UG, ZM, ZW), Eurasian (AM, AZ, BY, KG, KZ, RU, TJ, TM), European (AL, AT, BE, BG, CH, CY, CZ, DE, DK, EE, ES, FI, FR, GB, GR, HR, HU, IE, IS, IT, LT, LU, LV, MC, MK, MT, NL, NO, PL, PT, RO, RS, SE, SI, SK, SM, TR), OAPI (BF, BJ, CF, CG, CI, CM, GA, GN, GQ, GW, ML, MR, NE, SN, TD, TG).

— *as to applicant's entitlement to apply for and be granted a patent (Rule 4.17(ii))*

— *of inventorship (Rule 4.17(iv))*

Published:

— *with international search report (Art. 21(3))*

Declarations under Rule 4.17:

— *as to the identity of the inventor (Rule 4.17(i))*

Composition for manufacturing a tannin-based foam material, foam material obtainable from it, and manufacturing process thereof

The present invention generally refers to foam materials adapted to be used in a wide range of applications and, typically, in the fields of building and in the automotive industry and in the vehicles in general.

Organic foam materials are known, used for a long time as insulating materials.

For example, polystyrene foam, polyurethane foam, mineral wool, cellulose wadding, wood-wool, hemp, and phenolic resin based foam materials are part of this category of materials.

However, polystyrene and polyurethane based foam materials, in spite of the fact that they have high thermal insulation properties, are very sensitive to fire and easily flammable, and they release very toxic gases during their combustion. However, phenolic foam materials, having better fire resistance properties, are more brittle and expensive.

Moreover, all these known foam materials have synthetic origin and contain chemical products deriving from petrochemical industry, and therefore are not renewable substances since their availability in nature is limited. Between these, wood-phenolic and tannin-resorcinol based foam materials are very brittle and comprise remarkable amounts of petrochemical compounds, therefore are not renewable and, after all, they are little eco-

compatible.

In particular, the invention relates to a composition for manufacturing a tannin-based foam material, of the type defined in the preamble of claim 1.

Flavonoid tannin based foam materials are already known, which flavonoid tannins consist of small polyphenolic molecules, mainly water-soluble, extracted from several plant species.

In particular, the invention refers to compositions based on tannins of the prorobineditinidin and profisetinidin type, typically obtained from barks of mimosa (*Acacia mearnsii*) or acacia (*Acacia mangium*) trees, or from quebracho (*Schinopsis lorenzii* and/or *Schinopsis balansae*) wood, through a not polluting extraction process carried out by means of warm water with or without additives, or by organic solvents. In particular, flavonoids of tannins are natural occurring products so that they are renewable, available in nature in great amounts, and they are not petrochemical derivatives.

Formulations used up to now in order to obtain foam materials containing tannins, potentially contain also relatively meaningful formaldehyde amounts, that is a polluting, toxic and carcinogenic product.

In particular, a composition is already known, used for manufacturing tannin based foam materials, that comprises 44,2% in weight of tannin, 15,5% in weight of furfuryl alcohol (FA),

10,9% in weight of formaldehyde (Fo), 4,4% in weight of diethyl ether (DEE), and 16,2% in weight of p-toluenesulfonic acid (p-TSA). This known composition is reported in the following as standard (STD).

However, it has been confirmed that formaldehyde releases into the air substances that can cause irritations and inflammations of the skin, of the eyes and of respiratory tracts, as well as adverse neurological effects such as headache, vertigos and fatigue, and that can also promote development of allergies and childhood asthma. Therefore, formaldehyde has been classified as a "suspicious carcinogenic" element in the UE, and as "surely carcinogenic" for the CIRC (Center of International Research on the Cancer, under the authority of the OMS).

As a result of standards that will be in force in short term (PNSE2), it will be compulsory to identify emissions from products containing formaldehyde, used for example for thermal insulation.

It would be therefore advisable to obtain a foam material by a composition comprising as much as possible resources available in nature, therefore of the renewable type, in particular without any need to use petrochemical based substances, having moreover low thermal conductivity properties, high fire resistance, low cost, easy preparation, low friability and good water resistance, and at the same time lacking in formaldehyde.

In particular, the object of the invention is to provide a composition for manufacturing a tannin based foam material, having the above mentioned desired features.

This object is reached by a composition as defined in appended claims 1 to 10.

By virtue of the composition subject of the invention, in view of the fact that the composition according to the invention comprises essentially tannin, furfuryl alcohol, a blowing agent and a catalyst, and by virtue of the fact that the composition contains an amount of furfuryl alcohol of 20% in weight and lacks completely in formaldehyde, it is possible to obtain a foam material of ecological origin, non toxic and the 90% of which is based on resources available in a great amount in nature, non petrochemical based.

In fact, furfuryl alcohol is a naturally occurring product deriving from catalytic reduction of furfural, that is obtained as a residual from hydrolysis of sugars of agricultural harvests.

Moreover, the foam materials obtainable from this composition are extremely light, little expensive, easy to produce, and have characteristics of good mechanical strength, high fire resistance, high degree of infusibility, absolute non flammability, reduced thermal conductivity, and therefore good properties of thermal insulation, as well as of water

resistance, compressive strength, and a better flexibility than that of the foam materials known up to now.

These characteristics makes extremely interesting for its use the foam material obtainable from the composition of the invention, in particular in the field of building materials, in the automotive industry and in the industry of vehicles in general.

Moreover, the subject of the invention is a foam material obtainable from said composition, such as defined in claim 11, as well as a process for manufacturing such foam material, as defined in claims 12 to 15.

Further characteristics and advantages of the invention will be clarified by the following detailed description, provided as a non limitative example and referred to the appended drawings in which:

- figure 1 comprises a series of electron microscope images a) to f) the for sections of samples of foam materials obtained starting from a composition according to the invention, as well as an image g) of a sample of a foam material obtained starting from a standard formulation according to the prior art,

- figure 2 is a diagram showing the bulk density of a series of foam materials according to the invention comprising 30g of tannin, as a function of the respective amount of furfuryl alcohol,

- figure 3 is a diagram showing the thermal conductivity of

a series of samples of foam material obtained from the composition of the invention, and of several foam materials known in the art, as a function of the respective bulk density, and

- figure 4 is a diagram showing the characteristic stress/strain curves obtained for a series of samples of foam materials according to the invention, and for a foam material obtained starting from a standard formulation of the prior art.

GENERAL DESCRIPTION OF THE COMPOSITION

A foam material according to the invention is obtained starting from a composition that mainly includes flavonoid tannin of the prorobineditinidin and/or profisetinidin type in the form of a powder, furfuryl alcohol (2-furylmethanol or 2-furancarbinol), a blowing agent, and a catalyst.

The tannin powder is used according to an amount in weight in the range between 40% and 45%.

The furfuryl alcohol is used according to an amount in weight greater than 20%, with the aim of replacing formaldehyde used in the known compositions, in order to avoid at all any use of formaldehyde in the composition of the invention and in the respective foam material.

As the blowing agent a liquid is used, the boiling point of which is between 30°C and 100°C, ideally between about 40°C and 60°C, conveniently based on ethyl ether, pentane, and/or a

mixture of isomers of pentane, and preferably consisting, in the following non limitative example, of diethyl ether.

The catalyst is of the acid, organic or inorganic, based type, and preferably consists of p-toluenesulfonic acid (p-TSA) or, as an alternative, trichloroacetic acid.

Water can also be used according to an amount in weight between 0% and 15% of the composition, for example between 8% and 9%.

Moreover, an isocyanate can be added to the composition, such as PMDI (polymeric diphenylmethane diisocyanate) with the aim of increasing mechanical strength of the foam material to be obtained.

In particular, the amount of blowing agent (for example diethyl ether) in the composition is greater than 5% in weight, and the catalyst amount (for example p-toluenesulfonic acid - p-TSA) is smaller than 16% in weight.

The aforesaid composition allows a foam material with high characteristics to be obtained, such as explained in more detail in the following, as a result of a process for manufacturing the foam material in a mould the shape of which corresponds to that of the material to be obtained.

EXAMPLES

Hereinafter, examples are described, for merely illustrative and non limitative purposes, of compositions that can be used for

manufacturing a tannin based foam material according to the invention, as well as the relevant manufacturing process, with particular reference to the following tables 1 and 2.

In table 1, the amounts in weight in grams of the components usable to prepare a series of samples of the new foam material, are shown.

These samples are indicated in general as Fx-y, where x and y are the amounts of the catalyst (p-TSA) and of the furfuryl alcohol (FA), respectively. Fo and DEE indicate the amounts of formaldehyde and diethyl ether, respectively. In the Table 1, for comparison, the standard composition (STD) of the known foam material is also mentioned.

SAMPLE	F9-18	F9-20	F9-22	F11-18	F11-20	F11-22	STD
p-TSA (g)	9	9	9	11	11	11	11
FA (g)	18	20	22	18	20	22	10.5
Fo (g)	0	0	0	0	0	0	7.4
DEE (g)	5	5	5	5	5	5	3
Water (g)	6	6	6	6	6	6	6
Tannin (g)	30	30	30	30	30	30	30

Table 1

The tannin based foam material lacking in formaldehyde according to the invention has been prepared as follows.

Initially, furfuryl alcohol (FA: from 18 to 22g), diethyl ether (DEE - blowing agent: 5g) and preferably water (6g), are stirred together. Then, 30g of tannin powder are progressively incorporated, by strongly stirring the mass during about 15s, for example using a helical stirrer of a type known per se.

Finally, 9 to 11g of catalyst, for example an organic acid, typically consisting of p-toluenesulfonic (p-TSA), is added by stirring during about 20s, and the mixture is poured in a mould the shape of which corresponds to that of the foam material intended to be obtained.

After a variable waiting time, of the order of some minutes, the catalyst starts auto-polymerization of the furfuryl alcohol with the tannin. This reaction, which is exothermic, generates heat and causes the blowing agent (DEE) to boil, which causes the beginning of the expansion step of the mixture in the mould. As an alternative, the heat necessary to the expansion of the composition can be supplied, also just in part, from an outer heat source.

Expansion takes place after a waiting time of some minutes, and it allows the mould to be filled in the best manner, until the foam material takes a shape corresponding to that defined by the mould. In this manner, it is possible to obtain a shape of the foam material of any geometry and volume.

In the following Table 2, the compositions of the same samples

mentioned in the Table 1, including the standard composition comprising formaldehyde, are provided, that are referred to the percentages in weight of their components.

SAMPLE	F9-18	F9-20	F9-22	F11-18	F11-20	F11-22	STD
p-TSA (%)	13.2	12.9	12.5	15.7	15.3	14.9	16.2
FA (%)	26.5	28.6	30.6	25.7	27.8	29.7	15.5
Fo (%)	-	-	-	-	-	-	10.9
DEE (%)	7.4	7.1	6.9	7.1	6.9	6.8	4.4
Water (%)	8.8	8.6	8.3	8.6	8.3	8.1	8.8
Tannin (%)	44.1	42.9	41.7	42.9	41.7	40.5	44.2
TOTAL	100%	100%	100%	100%	100%	100%	100%

Table 2

With reference to the amounts of Table 2, in a first step of the manufacturing process of the foam material, the furfuryl alcohol, according to an amount in weight greater than 20%, and the blowing agent, typically diethyl ether according to an amount in weight greater than 5%, are stirred together.

Preferably, water according to an amount in weight between about 8% and 9% of the final composition, is added to the mixture so obtained.

The tannin powder is then incorporated in the mixture so obtained, according to an amount between 40% and 45% in weight, and the mixture is stirred again.

Then, an acid based catalyst, typically p-toluenesulfonic acid (p-TSA) or, as an alternative, trichloroacetic acid, is added according to an amount in weight smaller than 16%, and stirred with the mixture.

An isocyanate can also be added to the mixture, such as PMDI, for example according to an amount variable between 5% and 20% in weight of the composition.

The mixture so obtained is poured into the mould, where the expansion thereof takes place, such as like previously described.

In particular, the formulation of the composition is optimized in order to prevent a too fast hardening of the foam material, and in order to avoid or minimize formation of porosities in the material, and also so that the material can not endure any sag or collapse as a result of a too long hardening step. In particular, by virtue of the appropriate balance between expansion and hardening of the foam material, it neither collapse nor breaks.

The same process was used to prepare the standard tannin based foam material (STD) containing formaldehyde, in order to compare the materials according to the invention and the material of the standard composition, as reported in the following.

EXAMINATION OF THE SAMPLES OBTAINED

All the samples of the foam materials obtained as described above, were cut in the shape of parallelepipeds, and were weighted in order to measure their bulk density.

All the samples proven to be homogenous and lacking in defects.

The small samples obtained were then metalized with gold, and examined by a Hitachi S 520 scanning electron microscope (SEM).

Their thermal conductivity was measured at room temperature with the TPS (transient plane source - Hot Disk TPS 2500) method, and also the measure of their compressive strength was carried out, by an Instron 4206 universal test machine having a load ratio of 2.0 mm/min.

Figure 1 shows the images obtained by the SEM with 50x magnification, for sections of the samples mentioned above, particularly in connection with the compositions F9-18 (a), F9-20 (b), F9-22 (c), F11-18 (d), F11-20 (e) and F11-22 (f) as mentioned in Tables 1 and 2, as well as for a section of the sample with the standard formulation containing formaldehyde (g) according to the prior art.

STRUCTURE OF THE SAMPLES OBTAINED

As it can be noticed from the images of figure 1, the structure of the most of the foam materials obtained shows closed and opened cells, spaced by thin membranes from the near cells. In

some zones, the membranes are broken, particularly in the case of higher amount of furfuryl alcohol, such as in the case of the samples (b), (c), (d) and (f).

As a result of a greater amount of p-TSA in the formulation (samples (d), (e), (f)) the structure of the foam material has relatively smaller cells, even if such effect is of small entity.

On the other hand, high amounts of furfuryl alcohol (FA) does not involve a clear effect on the average dimension of the cells, but they cause a meaningfully reduction in the bulk density of the relevant material. At any rate, it is preferable to use amounts of furfuryl alcohol only within a narrow range (from 18 to 22g, with reference to Table 1), otherwise the foam material is little stable and little homogenous.

Figure 2 shows the bulk density (g/cm^3) of the samples of the foam material according to the invention, that is in connection with the compositions F9-18, F9-20, F9-22, F11-18, F11-20 and F11-22, as a function of the amount in weight of furfuryl alcohol used in the relevant compositions, and referred to samples of foam material containing 30g of tannin.

As it can be noticed from figure 2, by increasing the amount of furfuryl alcohol, the bulk density of the respective foam material is reduced, and therefore, in other words, the material is "more expanded". In fact, a higher amount of

furfuryl alcohol causes a more exothermic reaction, which serves as the basis for the growth of the relevant foam material. Therefore, less catalyst can be used (9g rather than 11g) without appreciably modifying the structure of the foam material. The tannin absorbs a part of the heat, which makes the foam material homogenous and causes a rather slow growth of it.

PROPERTIES OF THE FOAM MATERIALS OF THE INVENTION

In general, it has been found that, with the composition of the present invention and in comparison with the standard composition of the prior art, the substitution of formaldehyde by greater amounts both of furfuryl alcohol or the blowing agent, allows a foam material to be obtained the characteristics of which are generally better than those obtainable by the standard compositions, and that, at any rate, allows any use of formaldehyde to be avoided.

In figure 3, thermal conductivities (W/m/°K) of the tannin based foam materials according to the invention are shown, as a function of the relative bulk density (g/cm³), in comparison with thermal conductivities of other foam materials known in the art, in particular of phenolic (PF), urea-formaldehyde-furfuryl (UFF) alcohol based, polyurethane (PU) based, phenolic wood (LPF) based and polyethylene (PE) based foam materials.

It can be noticed that the materials of the present invention

have a lower thermal conductivity in view of a low bulk density, and therefore their thermal insulation characteristics are fully comparable with those of the polyurethane (PU) based foam materials, and are better than those of the phenolic (PF), or alcohol urea-formaldehyde-furfuryl (UFF) based foam materials. It must be taken into account that, however, PU based foam materials are more fire sensitive and they release highly toxic compounds during their combustion.

In the case of the materials according to the invention, their non flammability characteristic, owing to the presence of furfuryl alcohol and tannin, makes them more favourable with respect to PU based materials.

In particular, between the tannin based foam materials, the thermal conductivity of those according to the present invention is lower than that of the standard (STD) composition containing formaldehyde, and therefore they are proven to be better from a thermal insulation point of view.

In Figure 4, the stress/compressive strain characteristics of the tannin based materials according to the invention are shown, in particular obtained for the foam material samples of the compositions F9-18, F9-20, F9-22, F11-18, F11-20 and F11-22, in comparison with the characteristics of the sample of the standard (STD) foam material containing formaldehyde.

The curves of figure 4 show the typical shape expected from

solids provided with a cellular structure, similar to that obtainable for the standard formulation containing formaldehyde. In particular, the stress/strain curves have three clearly recognizable zones: an initial zone of linear elastic response, a substantially flat intermediate zone or "plateau", and a final "densification" zone. The most of the foam materials according to the invention have a good elastic behavior, and therefore a smaller rigidity, with respect to the standard (STD) material, except for the composition F11-18. Consequently, foam materials obtained from compositions F9-18, F9-20, F9-22, F11-20 and F11-22, are less brittle than the standard (STD) material containing formaldehyde, and therefore they do not break easily. Moreover, their module of elasticity is meaningfully smaller. This involves a meaningful improvement with respect to the previously known tannin and formaldehyde based formulation.

This behavior is owed to the fact that formaldehyde easily immobilizes tannin molecules during cross-linking, and therefore it strongly reduces mobility of such molecules, which causes an incomplete polymerization and the formation of a brittle polymeric lattice of the vitreous type. Therefore, absence of formaldehyde in the compositions of the present invention allows a much higher flexibility to be obtained in the polymer chains of the relevant foam materials.

Usually, foam materials are classified as rigid, partially

rigid or flexible, on the basis of their compressive strength: > 0.08 MPa, $0.015 \div 0.08$ MPa and < 0.015 MPa, respectively.

The foam materials of the F9-18, F9-20, F9-22, F11-18 and F11-20 type according to the invention are essentially rigid, while the material of the F11-22 type, having the lower bulk density (figure 2), is actually soft. Since the material F11-22 is also that showing the smallest thermal conductivity, of about 0.038 W/m/°K (figure 3), it is particularly interesting because it combines a relevant lightness and very good insulation qualities besides its natural origin, with fire-proof and low cost properties.

Moreover, the foam materials of the invention are considerably less hydrophilic than the similar materials containing formaldehyde, and they have a very low wettability. In fact, a water drop placed on their surface requires a very long time, in the order of $5 \div 10$ minutes, to be slowly soaked since, owing to porosity of the material, water is gradually dispersed in it.

Instead, in the previously known standard formulation, water is soaked in a very fast manner, and the water amount that can be soaked by the dry foam material, may reach up to seven times its initial weight.

In conclusion, a tannin based foam material according to the invention can be obtained as a result of a "more ecological"

preparation, without any use of formaldehyde.

The materials according to the invention, compared with the first generation of tannin based foam materials containing formaldehyde, have in general a lower bulk density, a lower reduced thermal conductivity that makes them adapted to be used as thermal insulating materials, and a lower hydrophily. Also, they are much less brittle than the similar materials containing formaldehyde, and they have a higher flexibility and a low friability, as well as good characteristics of mechanical strength. Moreover they do not burn and are auto-extinguishing and, if subject to a high amount of heat, consumes slowly.

CLAIMS

1. Composition for manufacturing a foam material based on flavonoid tannins, mainly of the prorobineditinidin and/or the profisetinidin type, according to an amount in weight usually in the range between 40% and 45% of the composition, furfuryl alcohol, a blowing agent, and a catalyst,

characterized in that it contains an amount of furfuryl alcohol greater than 20% in weight of the composition, and in that it is totally formaldehyde-free.

2. Composition according to claim 1, characterized in that said blowing agent has a boiling point between 30°C and 100°C, preferably between 40°C and 60°C.

3. Composition according to claim 2, characterized in that said blowing agent is based on ethylether, pentane, and/or a mixture of pentane isomers.

4. Composition according to claim 3, characterized in that said blowing agent is diethyl ether.

5. Composition according to any one of claims 1 to 4, characterized in that said catalyst is based on an acid, of the organic or of the inorganic type.

6. Composition according to claim 5, characterized in that said catalyst is p-toluensulfonic acid (p-TSA).

7. Composition according to claim 5, characterized in that

said catalyst is trichloroacetic acid.

8. Composition according to any one of claims 1 to 7, characterized in that it contains an amount of blowing agent greater than 5% in weight, and an amount of catalyst smaller than 16% in weight of the composition.

9. Composition according to any one of claims 1 to 8, characterized in that it contains an amount of water between 0% and 15% in weight of the composition.

10. Composition according to claim 8 or 9, characterized in that it contains furthermore an isocyanate, such as PMDI.

11. Tannin-based organic foam material, characterized in that it is obtainable from a composition according to any one of claims 1 to 10.

12. Process for manufacturing a product of organic foam material usable as a thermal insulator, characterized in that it comprises the steps of:

- preparing a mould the shape of which corresponds to that of the product to be obtained,
- preparing furfuryl alcohol and a blowing agent the boiling point of which is comprised in the range between 30°C and 100°C, preferably in the range between 40°C and 60°C, such as diethyl ether, and mixing together such components,
- preparing a flavonoid tannin powder, mainly of the prorobineditinidin and/or the profisetinidin type, and

incorporating it in the mixture including the furfuryl alcohol and the blowing agent, and mixing the mixture so obtained,

- preparing an acid-based catalyst, such as p-toluensulfonic acid (p-TSA) or trichloroacetic acid, adding it to the mixture obtained, and submitting the whole mixture to mixing,
- pouring the composition obtained in said mould, allowing reaction of the components to continue, until the composition is completely foamed in the mould.

13. Process according to claim 12, characterized in that it comprises furthermore the step of joining a predetermined amount of water to the mixture of furfuryl alcohol and blowing agent.

14. Process according to claim 12 or 13, characterized in that the furfuryl alcohol is prepared according to an amount greater than 20% in weight of the composition, the blowing agent according to an amount greater than 5% in weight of the composition, the water according to an amount between about 0% and 15% in weight of the composition, the catalyst according to an amount less than 16% in weight of the composition, and the tannin according to an amount between 40% and 45% in weight of the composition.

15. Process according to claim 14, characterized in that it comprises also the step of preparing an isocyanate, such as PMDI, and of adding it to the aforesaid mixture of components.

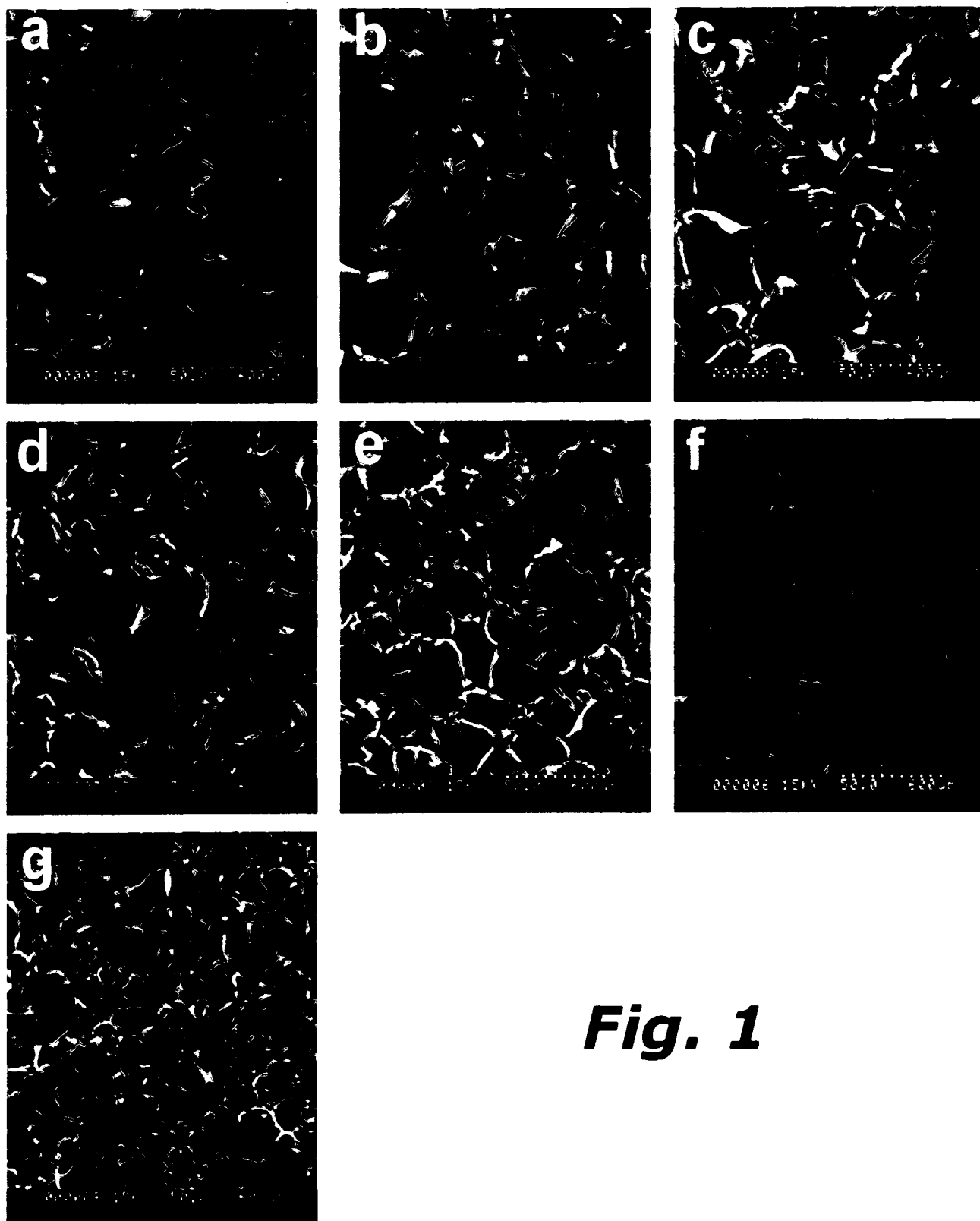

Fig. 1

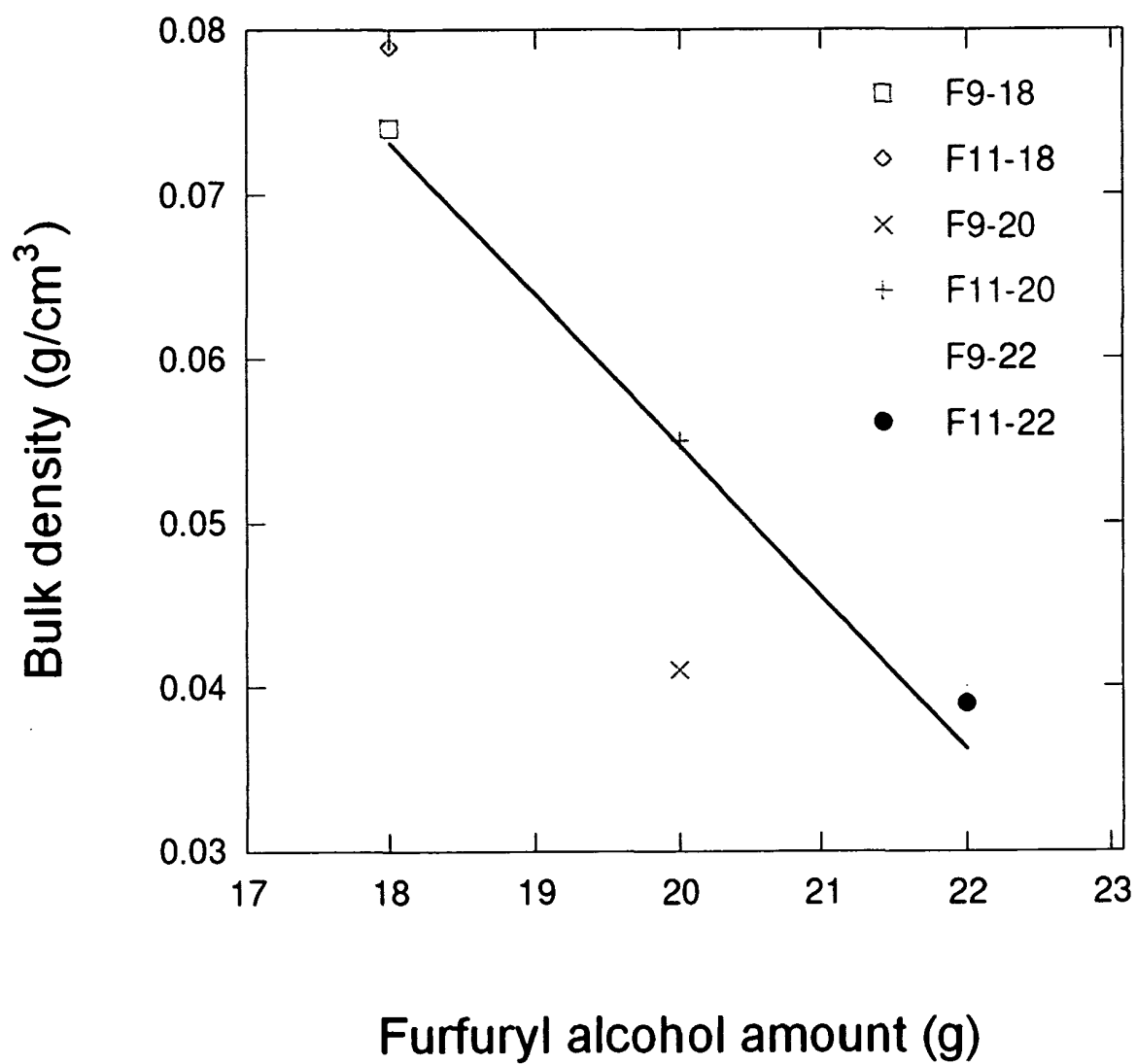

Fig. 2

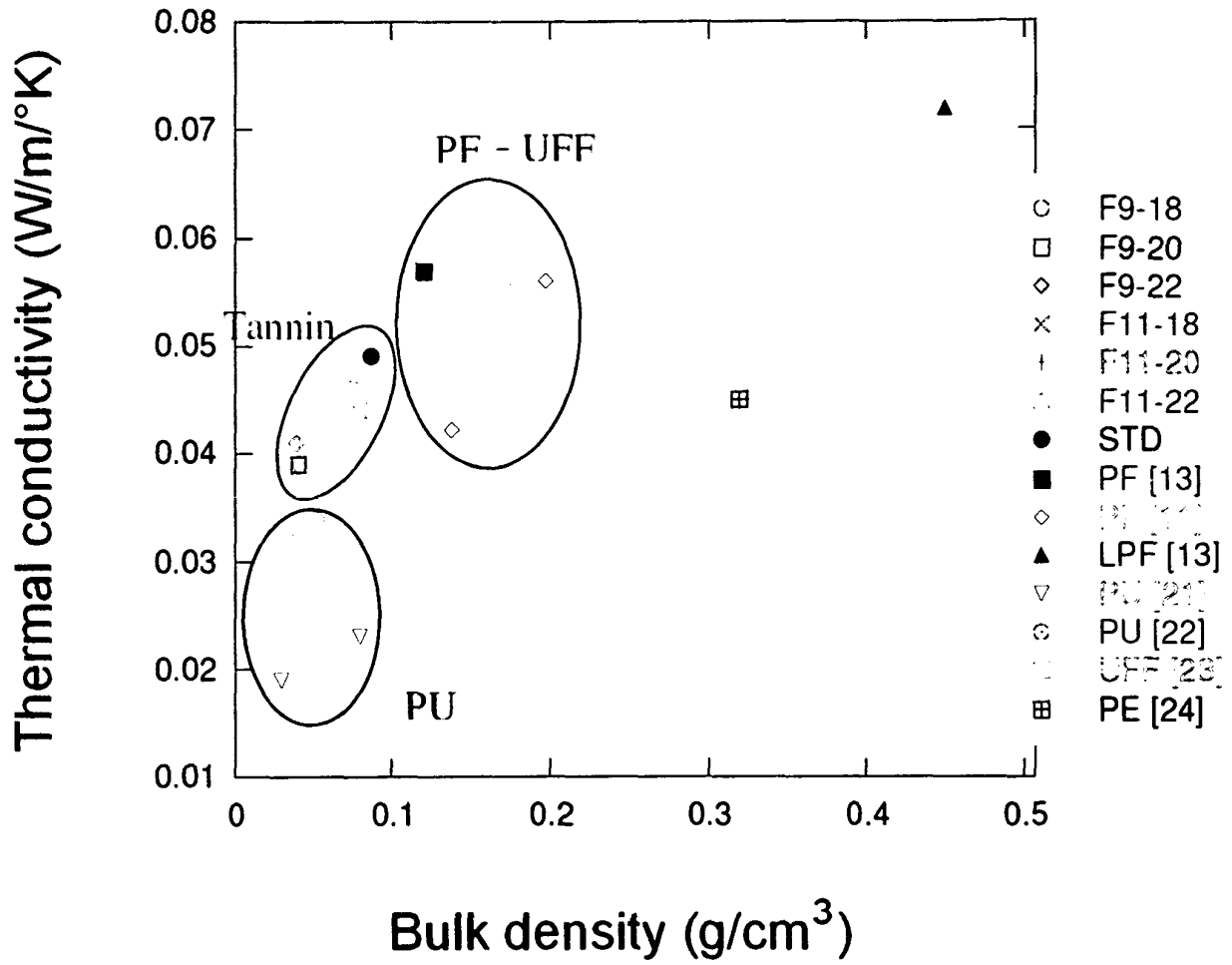

Fig. 3

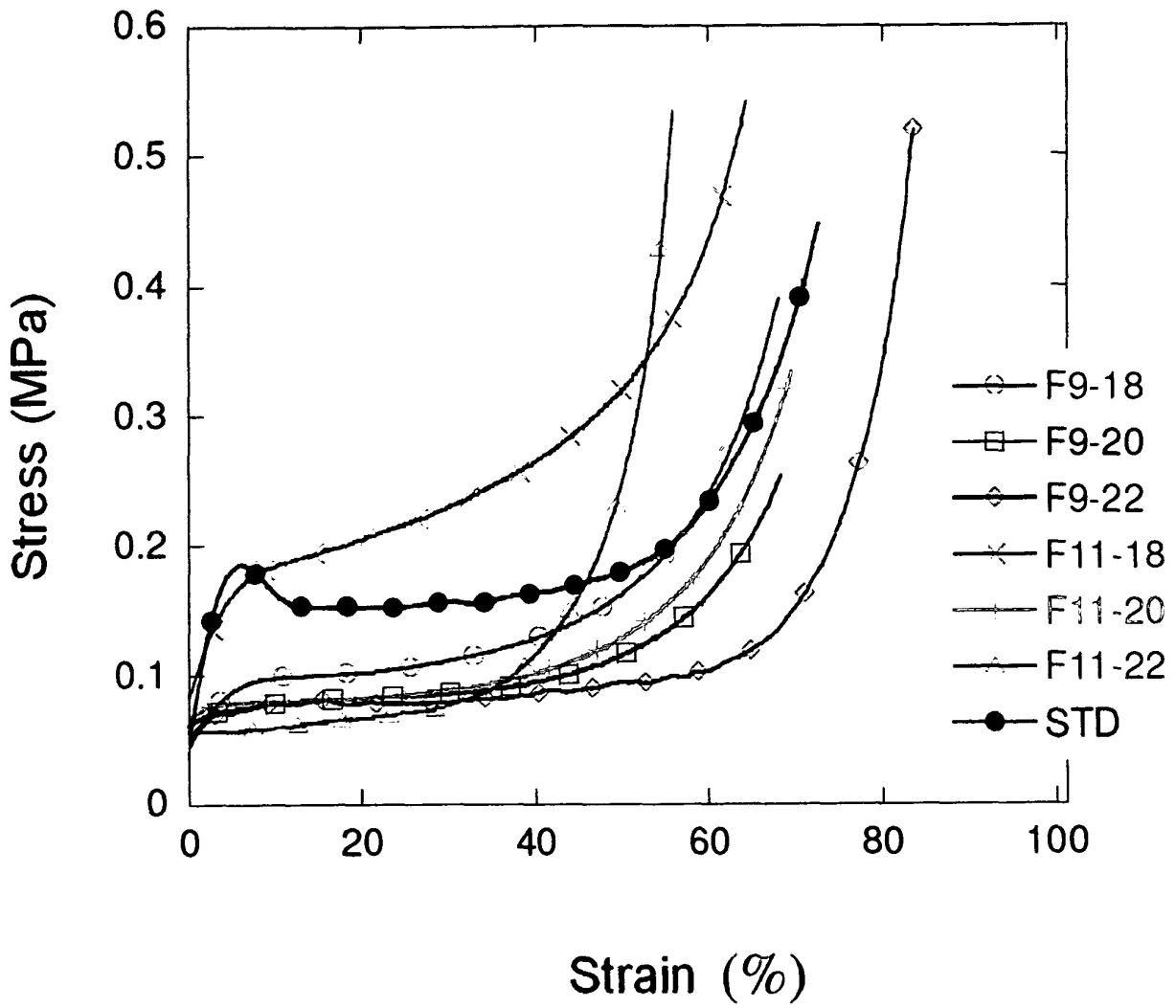

Fig. 4

INTERNATIONAL SEARCH REPORT

International application No
PCT/EP2012/003031

<p>A. CLASSIFICATION OF SUBJECT MATTER INV. C08G8/34 C08J9/00 C08J9/14 ADD.</p>		
<p>According to International Patent Classification (IPC) or to both national classification and IPC</p>		
<p>B. FIELDS SEARCHED</p>		
<p>Minimum documentation searched (classification system followed by classification symbols) C08J C08G</p>		
<p>Documentation searched other than minimum documentation to the extent that such documents are included in the fields searched</p>		
<p>Electronic data base consulted during the international search (name of data base and, where practicable, search terms used) EPO-Internal</p>		
<p>C. DOCUMENTS CONSIDERED TO BE RELEVANT</p>		
Category*	Citation of document, with indication, where appropriate, of the relevant passages	Relevant to claim No.
A	US 2006/084718 A1 (STANCLIFFE MARK R [GB] ET AL) 20 April 2006 (2006-04-20) paragraphs [0008] - [0012], [0017] - [0021]; claims 1-26 -----	1-15
A	TROSA ET AL: "INDUSTRIAL HARDBOARD AND OTHER PANELS BINDER FROM TANNIN/FURFURYL ALCOHOL IN ABSENCE OF FORMALDEHYDE", HOLZ ALS ROH- UND WERKSTOFF, SPRINGER-VERLAG. BERLIN, DE, vol. 56, no. 3, 1 January 1998 (1998-01-01), pages 213-214, XP008078348, ISSN: 0018-3768, DOI: 10.1007/S001070050301 the whole document ----- -/--	1-15
<p><input checked="" type="checkbox"/> Further documents are listed in the continuation of Box C. <input checked="" type="checkbox"/> See patent family annex.</p>		
<p>* Special categories of cited documents :</p>		
<p>"A" document defining the general state of the art which is not considered to be of particular relevance</p> <p>"E" earlier application or patent but published on or after the international filing date</p> <p>"L" document which may throw doubts on priority claim(s) or which is cited to establish the publication date of another citation or other special reason (as specified)</p> <p>"O" document referring to an oral disclosure, use, exhibition or other means</p> <p>"P" document published prior to the international filing date but later than the priority date claimed</p>		<p>"T" later document published after the international filing date or priority date and not in conflict with the application but cited to understand the principle or theory underlying the invention</p> <p>"X" document of particular relevance; the claimed invention cannot be considered novel or cannot be considered to involve an inventive step when the document is taken alone</p> <p>"Y" document of particular relevance; the claimed invention cannot be considered to involve an inventive step when the document is combined with one or more other such documents, such combination being obvious to a person skilled in the art</p> <p>"&" document member of the same patent family</p>
<p>Date of the actual completion of the international search 22 October 2012</p>		<p>Date of mailing of the international search report 02/11/2012</p>
<p>Name and mailing address of the ISA/ European Patent Office, P.B. 5818 Patentlaan 2 NL - 2280 HV Rijswijk Tel. (+31-70) 340-2040, Fax: (+31-70) 340-3016</p>		<p>Authorized officer Clement, Silvia</p>

INTERNATIONAL SEARCH REPORT

International application No

PCT/EP2012/003031

C(Continuation). DOCUMENTS CONSIDERED TO BE RELEVANT

Category*	Citation of document, with indication, where appropriate, of the relevant passages	Relevant to claim No.
A	DE 26 25 811 A1 (AFRICAN TERRITORIES WATTLE IND) 16 December 1976 (1976-12-16) page 4, paragraph 2; claims 1-30; examples 1-7 -----	1-15
A	ZHAO W ET AL: "Effect of composition and processing parameters on the characteristics of tannin-based rigid foams. Part I: Cell structure", MATERIALS CHEMISTRY AND PHYSICS, ELSEVIER SA, SWITZERLAND, TAIWAN, REPUBLIC OF CHINA, vol. 122, no. 1, 1 July 2010 (2010-07-01), pages 175-182, XP026996542, ISSN: 0254-0584 [retrieved on 2010-04-10] abstract -----	1-15
A	US 2007/299167 A1 (CHEN GANG-FUNG [US] ET AL) 27 December 2007 (2007-12-27) claims 1-4; table 2 -----	1-15

INTERNATIONAL SEARCH REPORT

Information on patent family members

International application No

PCT/EP2012/003031

Patent document cited in search report	Publication date	Patent family member(s)	Publication date
US 2006084718	A1	20-04-2006	
		AU 2005295837 A1	27-04-2006
		BR PI0516587 A	16-09-2008
		CA 2581167 A1	27-04-2006
		CN 101039884 A	19-09-2007
		EP 1799625 A2	27-06-2007
		JP 4937918 B2	23-05-2012
		JP 2008516774 A	22-05-2008
		KR 20070057244 A	04-06-2007
		RU 2353597 C2	27-04-2009
		US 2006084718 A1	20-04-2006
		US 2007149644 A1	28-06-2007
		WO 2006044431 A2	27-04-2006

DE 2625811	A1	16-12-1976	NONE

US 2007299167	A1	27-12-2007	
		AR 061639 A1	10-09-2008
		CL 18582007 A1	13-06-2008
		TW 200815557 A	01-04-2008
		US 2007299167 A1	27-12-2007
		WO 2007149589 A2	27-12-2007

Mousses vertes, sans formaldéhyde, pour l'isolation thermique.

Auteurs: M.C.BASSO, X.LI, S.GIOVANDO, V.FIERRO, A.PIZZI, A.CELZARD
Advanced Materials Letters, 2(6): 378-382 (2011)

Dans cette étude, nous avons décrit de nouvelles mousses rigides, « vertes » et peu coûteuses qui présentent des performances exceptionnelles pour l'isolation thermique. De tels matériaux cellulaires ultralégers, principalement composés de produits chimiques renouvelables (tanins et alcool furfurylique) sont très faciles à produire et ont une conductivité thermique de l'ordre de 38 mW/m/K. Par rapport aux mousses à base de tanins précédemment rapportées, ces nouveaux matériaux sont beaucoup plus «verts» et présentent une meilleure résistance à la compression et à l'eau. En particulier, le formaldéhyde, autrefois utilisé comme agent de réticulation des tanins, mais connu comme une substance chimique volatile et dangereuse, peut être éliminé avec succès de la formulation. Ces mousses de tanins de 2^{ème} génération sont totalement stables et ont un intérêt attendu pour l'isolation thermique des bâtiments.

M.C.BASSO, X.LI, S.GIOVANDO, V.FIERRO, A.PIZZI, A.CELZARD, Green, formaldehyde-free, foams for thermal insulation, *Advanced Materials Letters*, 2(6): 378-382 (2011)

Green, formaldehyde-free, foams for thermal insulation

Maria C. Basso¹, Xinjun Li^{1,2}, Vanessa Fierro¹, Antonio Pizzi², Samuele Giovando³, Alain Celzard^{1*}

¹Institut Jean Lamour - UMR CNRS 7198, CNRS Nancy-Université UPV Metz, Département Chimie et Physique des Solides et des Surfaces. ENSTIB, 27 rue Philippe Séguin, BP 1041, 88051 Épinal cedex 9, France

²ENSTIB-LERMAB, Nancy Université, 27 rue Philippe Séguin, BP1041, 88051 Epinal cedex 9, France

³SILVA Chimica, Via Torre, S.Michele Mondovo (CN), Italy

*Corresponding author. Tel: (+33) 329 296114; Fax: (+33) 329 296138; E-mail: Alain.Celzard@enstib.uhp-nancy.fr

Received: 16 April 2011, Revised: 22 July 2011 and Accepted: 26 July 2011

ABSTRACT

New, green and cheap rigid foams presenting outstanding performances for thermal insulation are described. Such ultra-lightweight cellular materials are mainly based on renewable chemicals: tannin and furfuryl alcohol, are very easy to produce and have thermal conductivity as low as 38 mW/m/K. Compared to previously reported tannin-based foams, these new materials are much “greener” and present improved resistance to compression and to water. Especially the formaldehyde, formerly used as cross-linking agent of tannins but known as a volatile and harmful chemical, could be successfully removed from the formulation. The as-obtained, 2nd generation, tannin-based foams are totally stable and have an expected interest for thermal insulation of buildings. Copyright © 2011 VBRI press.

Keywords: Rigid foam; formaldehyde; thermal conductivity; bulk density

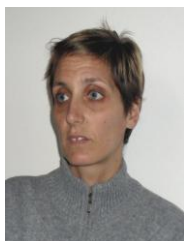

M.C. Basso obtained her PhD from the University of Buenos Aires (Chemistry). She worked for years in the industry as head of R&D in Argentina. At present, she is pursuing post-doctoral studies in the field of “tannin-based-foams” at Université Henri Poincaré, France.



A. Celzard graduated in Chemical Physics in 1992 and received his PhD in Materials Science in 1995 at the University Henri Poincaré (Nancy, France). His scientific interests deal with disordered, porous, and related materials, ranging from composites and nanoporous adsorbents to macroporous solid foams, with applications in catalysis, depollution, energy and gas storage.



A. Pizzi holds a Dr.Chem. from the University of Rome, Italy, a Ph.D. in organic chemistry from the University of the Orange Free State, South Africa, and a D.Sc. in Wood Chemistry from the University of Stellenbosch, South Africa. His specialities are polycondensation resins and adhesives, resins derived from renewable resources, polymers and composites. He is the holder of several international prizes in his fields of specialization.

Introduction

Organic foams have been suggested and used for long as insulating materials [1]. Low density, mechanical resistance, and narrow and closed porosity are the main criteria. However, infusibility, fire retardance, “green” origin, and low cost are highly sought after additional features. No presently commercialised foam is able to combine simultaneously all these benefits. For instance, expanded or extruded polystyrene and polyurethane foams are very sensitive to fires [2, 3], whereas phenolic foams are thermally resistant [4-7] but are more fragile and expensive [8-12]. Moreover, all these materials are synthetic and based on chemicals derived from the petrochemical industry. Lignophenolic foams [13] and tannin-resorcinol foams [14-16] are much greener but remain brittle and are still based on various amounts of non renewable compounds.

In the present communication, foams based on natural resources at the 90% level are presented for the first time. Their composition is mainly based on flavonoid tannins, being small polyphenolic molecules extracted from some tree species [17], and on furfuryl alcohol, a residue from the hydrolysis of the sugars from several agricultural crops [18]. The main present advance, compared to materials from the same authors already described in former works

[19, 20], is the complete absence of formaldehyde. The latter was indeed used so far as the cross-linking agent in the formulation, allowing a fast and strong hardening of the material after foaming. However, it is known for its volatility and for its toxicity. On 10 June 2011, the US National Toxicology Program has even described formaldehyde as “known to be a human carcinogen” [21]. The major obstacle that could be overcome here is producing more ecologic foams with even improved properties despite the lack of formaldehyde.

The interest for biosourced materials for various purposes is quickly increasing [22-25]. Moreover, biosourced materials are much more acceptable from the societal point of view than synthetic ones, especially for in-house applications. However, this statement is true provided that these new materials don't comprise potentially hazardous chemicals which might be slowly released in the atmosphere. This is the reason why new formaldehyde-free formulations were looked for and motivated the present work. After describing their preparation, characterizations in terms of structure, thermal conductivity and mechanical resistance are carried out. We show that such foams are both greener and present higher performances than previously reported tannin-based foams containing formaldehyde.

Experimental

Foam preparation

Formaldehyde-free tannin-based foams were prepared as follows. Furfuryl alcohol (16 to 22 g), water (6 g) and diethylether (blowing agent: 3 to 5 g) were first mixed together. Then, 30 g of tannin were progressively incorporated, strongly stirring the bulk during 15 s. Finally, p-toluenesulfonic acid (catalyst: 9 to 11 g) was added under stirring during 20 s, and the mixture was poured into a mould. After a several-minutes long induction period, after which heat was generated by the auto-polymerisation of furfuryl alcohol and its reaction with tannin under acid conditions, boiling of diethyl ether occurred and therefore foaming started. Due to a subtle balance between growing and hardening, the foams neither collapsed nor cracked. The same procedure was used for preparing one “standard” tannin-based foam according to the composition optimized in our past works [14, 26, 27]. All the compositions tested are reported in **Table 1**. Absence of formaldehyde in the new foams was compensated by higher amounts of furfuryl alcohol, which had an impact on the amounts of catalyst and blowing agent. Hardening, and hence stabilisation of the material after foaming, indeed strongly depends on temperature: the higher the temperature, the easier the hardening. Adding more furfuryl alcohol, polymerizing in the presence of acid, generated more heat, thus allowed decreasing the amount of catalyst in the formulation. Doing this, more blowing agent was thus needed for reaching the same low densities as in the absence of formaldehyde. However, these effects are not so significant, and different formulations could also be prepared and successfully foamed, except 2 samples (see below).

Foam characterization

All the foams were cut into parallelepipeds and weighed in order to measure their bulk density. All were homogeneous and flawless, except samples F9-16 and F11-16 who did not rise, and were thus not characterized. Small sample pieces were metallised with gold and examined in a Hitachi S 520 scanning electron microscope. Thermal conductivity was measured by the transient plane source method (Hot Disk TPS 2500) at room temperature, and the resistance to compression was obtained with an Instron 4206 universal testing machine at a load rate of 2.0 mm min⁻¹.

Table 1. Composition of new foams, termed Fx-y, where x and y are the amounts of catalyst (p-TSA) and furfuryl alcohol (FA), respectively, compared to the standard (STD) composition. Fo and DEE stand for formaldehyde and diethylether, respectively.

Sample name	F9-16	F9-18	F9-20	F9-22	F11-16	F11-18	F11-20	F11-22	STD
p-TSA (g)	9	9	9	9	11	11	11	11	11
FA (g)	16	18	20	22	16	18	20	22	10.5
Fo (g)	0	0	0	0	0	0	0	0	7.4
(g)	5	5	5	5	5	5	5	5	3

Results and discussion

Foam structure

SEM pictures of formaldehyde-free foams are presented in **Fig. 1** and compared to the standard formulation with formaldehyde. Most cells are closed and separated from their neighbours by thin membranes. In some places, the membranes were crazed, especially at higher amounts of furfuryl alcohol. Adding more pTSA in the formulation led to smaller cells but the effect was low. In contrast, higher amounts of furfuryl alcohol had no clear impact on the average pore size but decreased significantly the bulk density, as seen in **Fig. 2**. Such an effect has been already observed in the past [15] but, in the present case, only a limited range of FA amounts (18 – 22 g) could be used, otherwise the foam was neither stable nor homogeneous.

The higher amount of furfuryl alcohol, compared to that of the standard formulation, produced a strongly exothermal reaction, allowing the rising of the foam. Because of this, less catalyst (9g instead of 11) could be used without noticeably changing the structure. Tannin absorbed part of the heat, making the foaming homogeneous and rather slow.

Foams properties

Thermal conductivities of new foams are presented in **Fig. 3**, and compared to other values taken from the literature for phenolic (PF) [11, 13], lignophenolic (LPF) [13], polyurethane (PU) [28, 29], urea-formaldehyde-furfuryl alcohol (UFF) [30] and polyethylene (PE) [31] foams. Though the thermal conductivity is not so low as that of PU foams, the latter are highly sensitive to fires, and release highly toxic compounds when burnt [2]. In the present case, the outstanding fire retardance of foams based on tannin and furfuryl alcohol has already been demonstrated [32] and is fully maintained here. Moreover, tannin – furfuryl alcohol mixtures are presently commercialised as binder for consolidating foundry sands [33].

Compression curves have the typical shape expected for cellular solids, already observed with standard formulations

comprising formaldehyde [14, 16, 27]. Stress-strain curves indeed presented three well identified regimes: linear elastic, plateau stress, and densification, as shown in Fig. 4. However, whereas standard tannin-based foams were brittle, formaldehyde-free materials are elastic and do not crack so easily. Their elastic modulus is also significantly lower. This is a significant improvement compared to the former formulation. Formaldehyde is known to immobilise easily tannin molecules during cross-linking, giving them an extremely low mobility. This feature leads to incomplete polymerization and to a brittle, vitreous polymer network [34]. Absence of formaldehyde consequently allowed a much higher flexibility of the polymer chains.

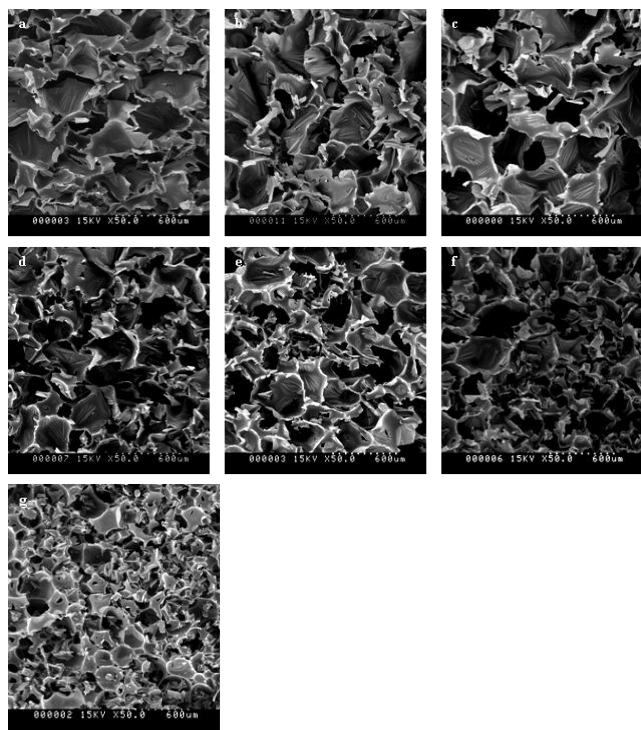

Fig. 1. SEM pictures (magnification 50 ×) of new foams (see Table 1) compared to the standard (STD) formulation. (a) F9-18; (b) F9-20; (c) F9-22; (d) F11-18; (e) F11-20; (f) F11-22; (g) STD.

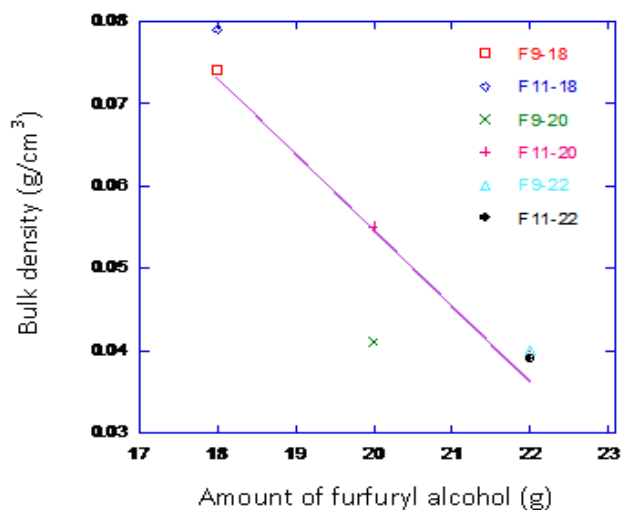

Fig. 2. Bulk densities of foams made from 30 g of tannins as a function of the additional amounts of furfuryl alcohol.

Foams are usually classified as stiff, partly stiff or flexible, according to their compression strength: > 0.08 MPa, 0.015 – 0.08 MPa, and < 0.015 MPa, respectively [35]. The new foams are mainly stiff, except the one having the lowest density, F11-22, which is really soft. Given that it is also the material having the lowest thermal conductivity, 0.038 W/m/K, F11-22 is the most interesting material of the series, combining lightness, insulating character, green origin, fire retardance and low cost.

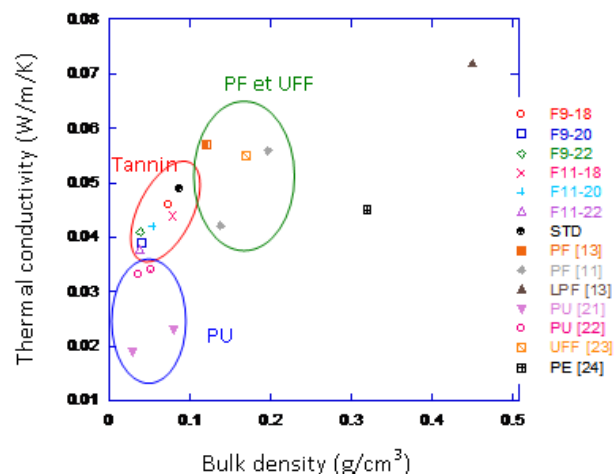

Fig. 3. Thermal conductivities of tannin-based foams as a function of their bulk densities. Several data from the literature were added for comparison (see text).

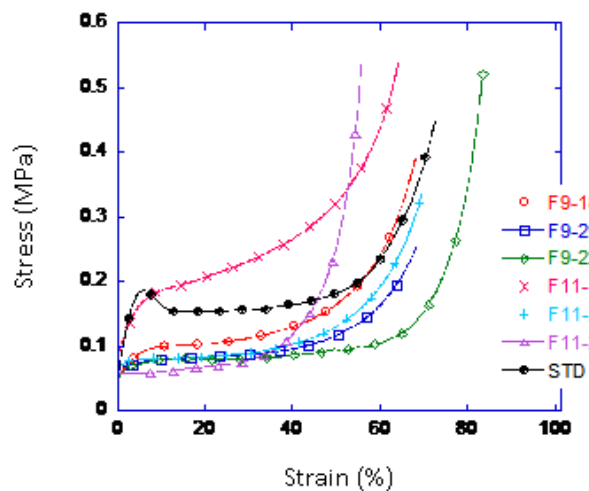

Fig. 4. Strain – stress characteristics of tannin-based foams submitted to compression.

Finally, though not yet investigated in detail, the new foams are considerably less hydrophilic than their formaldehyde-bearing counterparts. One water drop put onto the surface of the new materials require a very long time, between 5 and 10 min, for being slowly absorbed. Given the very low wettability, absorption probably occurs because of the porosity of the material, water gradually spreading onto itself. In contrast, water absorption of the former formulation was fast and significant, up to 7 times the initial weight of the dry foam [16]. Water absorption experiments are presently in progress, but much lower hydrophilicity was already clearly evidenced.

Conclusion

We clearly showed the possibility of preparing “greener”, formaldehyde-free, rigid foams for thermal insulation. The new materials have, compared to the first generation of tannin-based foams, lower density, lower thermal conductivity, and lower hydrophilicity but are also much less brittle due to a much higher flexibility. Such significantly improved characteristics could be obtained through the replacement of formaldehyde with furfuryl alcohol, a renewable chemical, and a higher amount of blowing agent.

Acknowledgement

The authors gratefully acknowledge the financial support of the CPER 2007-2013 “Structuration du Pôle de Compétitivité Fibres Grand’Est” (Competitiveness Fibre Cluster), through local (Conseil Général des Vosges), regional (Région Lorraine), national (DRRT and FNADT) and European (FEDER) funds.

Reference

- Iwasaki, K. In *Handbook of Plastic Foams*; Landrock, A.H.; Noyes Publications: Park Ridge, NJ, **1995**, 183-220.
- Stec, A.; Hull, T. *Energ. Buildings*. **2011**, *43*, 498.
DOI: [10.1016/j.enbuild.2010.10.015](https://doi.org/10.1016/j.enbuild.2010.10.015)
- Lefebvre, J.; Bastinm, B.; Le Bras, M.; Duquesne, S.; Paleja, R.; Delobel, R. *Polym. Degrad. Stab.* **2005**, *88*, 28.
DOI: [10.1016/j.polyimdegradstab.2004.01.025](https://doi.org/10.1016/j.polyimdegradstab.2004.01.025)
- De Carvalho, G.; Frollini, E. *J. Macromol. Sci. - Pure Appl. Chem. A*. **2002**, *39*, 643.
DOI: [10.1081/MA-120004509](https://doi.org/10.1081/MA-120004509)
- Tyberg, C.; Bergeron, K.; Sankarapandiann, M.; Shih, P.; Loos, A.; Dillard, D.; et al. *Constr. Build. Mater.* **1999**, *13*, 343.
DOI: [10.1016/S0950-0618\(99\)00022-7](https://doi.org/10.1016/S0950-0618(99)00022-7)
- Tessier, N. Proceedings 46th International SAMPE Symposium, **2001**, 2593.
- Auad, M.; Zhao, L.; Shen, H.; Nutt, S.; Sorathia, U. *J. Appl. Polym. Sci.* **2007**, *104*, 1399.
DOI: [10.1002/app.24405](https://doi.org/10.1002/app.24405)
- Okzul, M.; Mark, E. *Polym. Eng. Sci.* **1994**, *34*, 794.
DOI: [10.1002/pen.760341003](https://doi.org/10.1002/pen.760341003)
- Riahi, F.; Doufroune, R.; Bouremel, C. *Int. J. Polym. Mater.* **2007**, *56*, 929.
DOI: [10.1080/00914030601139076](https://doi.org/10.1080/00914030601139076)
- Shen, H.; Nutt, S. *Composites A*. **2003**, *34*, 899.
DOI: [10.1016/S1359-835X\(03\)00136-2](https://doi.org/10.1016/S1359-835X(03)00136-2)
- Shutov, F. *Cell. Polym.* **1984**, *3*, 95.
- Rangari, V.; Hassan, T.; Zhou, Y.; Mahfuz, H.; Jeelani, S.; Prorok, B. *J. Appl. Polym. Sci.* **2007**, *103*, 308.
DOI: [10.1002/app.25287](https://doi.org/10.1002/app.25287)
- De Carvalho, G.; Pimenta, J.; dos Santos, W.; Frollini, E. *Polym. Plast. Tech. Eng.* **2003**, *42*, 605.
DOI: [10.1081/PPT-120023098](https://doi.org/10.1081/PPT-120023098)
- Tondi, G.; Zhao, W.; Pizzi, A.; Du, G.; Fierro, V.; Celzard, A. *Biores. Technol.* **2009**, *100*, 5162.
DOI: [10.1016/j.biortech.2009.05.055](https://doi.org/10.1016/j.biortech.2009.05.055)
- Zhao, W.; Pizzi, A.; Fierro, V.; Du, G.; Celzard, A. *Mater. Chem. Phys.* **2010**, *122*, 175.
DOI: [10.1016/j.matchemphys.2010.02.062](https://doi.org/10.1016/j.matchemphys.2010.02.062)
- Zhao, W.; Fierro, V.; Pizzi, A.; Du, G.; Celzard, A. *Mater. Chem. Phys.* **2010**, *123*, 210.
DOI: [10.1016/j.matchemphys.2010.03.084](https://doi.org/10.1016/j.matchemphys.2010.03.084)
- Pizzi, A. *Advanced wood adhesives technology*; Marcel Dekker Inc: New York, **1994**.
DOI: [10.1002/pi.1996.210390117](https://doi.org/10.1002/pi.1996.210390117)
- Aguilar, R.; Ramirez, J.; Garrote, G.; Vazquez, M. *J. Food Eng.* **2002**, *55*, 309.
DOI: [10.1016/S0260-8774\(02\)00106-1](https://doi.org/10.1016/S0260-8774(02)00106-1)
- Meikleham, N.; Pizzi, A. *J. Appl. Polym. Sci.* **1994**, *53*, 1547.
DOI: [10.1002/app.1994.070531117](https://doi.org/10.1002/app.1994.070531117)
- Tondi, G.; Pizzi, A. *Ind. Crops Prod.* **2008**, *29*, 356.
DOI: [10.1016/j.indcrop.2008.07.003](https://doi.org/10.1016/j.indcrop.2008.07.003)
- U.S. Department of Health and Human Services, Public Health Service, National Toxicology Program. Report on Carcinogens, Twelfth Edition, 10 June **2011**.
- Mourya, V.K.; Inamdar, N.N.; Tiwari, A. *Adv. Mater. Lett.* **2010**, *1*, 11.
DOI: [10.5185/amlett.2010.3108](https://doi.org/10.5185/amlett.2010.3108)
- Singha, A.S.; Rana, R.K. *Adv. Mater. Lett.* **2010**, *1*, 156.
DOI: [10.5185/amlett.2010.6134](https://doi.org/10.5185/amlett.2010.6134)
- Kumar, S.; Negi, Y.S.; Upadhyaya, J.S. *Adv. Mater. Lett.* **2010**, *1*, 246.
DOI: [10.5185/amlett.2010.9164](https://doi.org/10.5185/amlett.2010.9164)
- Kalia, S.; Kumar, A.; Kaith, B.S. *Adv. Mater. Lett.* **2010**, *2*, 17.
DOI: [10.5185/amlett.2010.6130](https://doi.org/10.5185/amlett.2010.6130)
- Tondi, G.; Blacher, S.; Léonard, A.; Pizzi, A.; Fierro, V.; Leban J.; Celzard, A. *Microsc. Microanal.* **2009**, *15*, 384.
DOI: [10.1017/S1431927609990444](https://doi.org/10.1017/S1431927609990444)
- Celzard, A.; Zhao, W.; Pizzi, A.; Fierro, V. *Mat. Sci. Eng. A*. **2010**, *527*, 4438.
DOI: [10.1016/j.msea.2010.03.091](https://doi.org/10.1016/j.msea.2010.03.091)
- Jarfelt, U.; Ramnäs, O. 10th International Symposium on District Heating and Cooling. Nanover, Germany, **2006**.
- Wu, J.; Sung, W.; Chu, H. *Int. J. Heat and Mass Transfer*. **1999**, *42*, 2211.
DOI: [10.1016/S0017-9310\(98\)00315-9](https://doi.org/10.1016/S0017-9310(98)00315-9)
- Ramos Salabarría, I.; Galego, N.; Galante, M.; Vazquez, A. *Cell. Polym.* **1991**, *10*, 227.
- Rodriguez-Perez, M.; Alonso, O.; Souto, J.; de Saja, J. *Polym. Test.* **1997**, *16*, 287.
DOI: [10.1016/S0142-9418\(96\)00050-5](https://doi.org/10.1016/S0142-9418(96)00050-5)
- Celzard, A.; Fierro, V.; Amaral-Labat, G.; Pizzi, A.; Torero, J. *Polym. Degrad. Stab.* **2011**, *96*, 477.
DOI: [10.1016/j.polyimdegradstab.2011.01.014](https://doi.org/10.1016/j.polyimdegradstab.2011.01.014)
- Patent WO/2006/044431 (Ashland licensing and intellectual property LLC), International Application No.: PCT/US2005/036611
- Roux, D.; Ferreira, D.; Hundt, H.; Malan, E. *Appl. Polym. Symp.* **28**. Proc. Cellul. Conf. 8th, Vol. 1, **1975**.
- Weber H. In *Ullmann's Encyclopedia of Industrial Chemistry*; VHC: Wiesbaden, **1985**; Vol. A 11, 435-463.
DOI: [10.1002/14356007.a11_435](https://doi.org/10.1002/14356007.a11_435)

ADVANCED *MATERIALS Letters*

Publish your article in this journal

[ADVANCED MATERIALS Letters](#) is an international journal published quarterly. The journal is intended to provide top-quality peer-reviewed research papers in the fascinating field of materials science particularly in the area of structure, synthesis and processing, characterization, advanced-state properties, and applications of materials. All articles are indexed on various databases including [DOAJ](#) and are available for download for free. The manuscript management system is completely electronic and has fast and fair peer-review process. The journal includes review articles, research articles, notes, letter to editor and short communications.

Submit your manuscript: <http://amlett.com/submitanarticle.php>

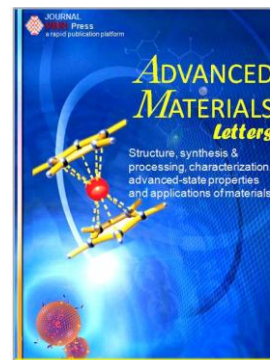

Mousses à base de tanins, sans formaldéhyde et sans solvant à bas point d'ébullition.

Auteurs: S.GIOVANDO, M.C.BASSO, A.PIZZI, A.CELZARD

Patent application number (Italy): TO2012A000860 (déposé le 2-10-2012)

Cette invention se réfère aux matériaux expansés à structure rigide ou solide à base de tanins condensés. Cette demande de brevet qui décrit la production de mousses qui ont la particularité d'être sans formaldéhyde et sans solvant a été déposée pendant la thèse.

Dans notre brevet antérieur, les mousses aux tanins sans formaldéhyde étaient décrites mais elles nécessitaient l'utilisation de solvants à bas point d'ébullition, comme l'éther éthylique ou le pentane, pour gonfler le matériau pendant la phase de polymérisation. Dans cette demande, nous décrivons la possibilité de gonfler les mousses aux tanins par l'addition d'une petite quantité d'isocyanate. L'isocyanate réagit avec les groupes -OH des tanins et aussi avec l'eau pour donner une molécule de CO₂.

Cette caractéristique est très intéressante car elle permet d'obtenir des mousses sans utilisation de solvants qui dans certains cas sont interdits ou compliquent la production des mousses par les compagnies. En effet, les mousses tanniques classiques, comme les mousses phénoliques, nécessitent une quantité d'environ 2 ou 3% de solvant. Même si ces pourcentages apparaissent relativement faibles, rapportés au tonnage global des mousses produites, ils sont loin de représenter des quantités négligeables. Les solvants libérés jusqu'après le moussage, pendant la production de ces matériaux peuvent réellement être préjudiciables pour l'environnement. Ainsi pour chaque tonne de mousses produites, 20 à 30 kg de solvant sont à gérer dans l'industrie, avec des coûts non négligeables.

S.GIOVANDO, M.C.BASSO, A.PIZZI, A.CELZARD, « Composizione a base di tanini vegetali, priva di formaldeide e di solventi organici bassobollenti, per la produzione di un materiale espanso, e relativo procedimento», Patent application number (Italy): TO2012A000860 (2-10-2012)

DESCRIZIONE dell'invenzione industriale dal titolo:

"Composizione a base di tannini vegetali, priva di formaldeide e di solventi organici bassobollenti, per la produzione di un materiale espanso, e relativo procedimento"

di: - UNIVERSITE' DE LORRAINE - INSTITUT ENSTIB -
LERMAB, nazionalità francese, 27 Rue Philippe
Séguin, BP 1041 88051 EPINAL cedex 9, FRANCIA;
- SILVACHIMICA S.r.l., nazionalità italiana,
Via Torre 7 - 12080 - San Michele Mondovì
(CN), ITALIA;

Inventori designati: Maria Cecilia BASSO, Samuele
GIOVANDO, Antonio PIZZI, Alain CELZARD;

Depositata il:

* * *

TESTO DELLA DESCRIZIONE

La presente invenzione si riferisce in generale ai materiali espansi, schiumosi o alveolari, altrimenti detti schiume, con struttura solida.

Questi materiali sono largamente utilizzati in una varietà di applicazioni, come nei settori del trasporto e dell'imballaggio, tipicamente per proteggere oggetti e merci, nei settori

dell'edilizia, dell'industria automobilistica, nautica o aeronautica come materiali di costruzione e per l'isolamento.

Sono noti materiali espansi utilizzabili per gli usi qui sopra menzionati, come le schiume poliuretatiche o fenoliche.

Le schiume fenoliche sono materiali molto versatili le cui proprietà sono modulabili per variare a piacimento le caratteristiche di maggiore o minore isolamento, di assorbimento dell'acqua, di bassa densità, ecc. Inoltre, le schiume fenoliche presentano generalmente una notevole resistenza al fuoco, ed hanno un costo relativamente basso che ne rende conveniente l'applicazione in molti settori.

Le schiume poliuretatiche o di polistirene, sebbene siano molto poco resistenti al fuoco, sono ampiamente utilizzate per impieghi simili, soprattutto per le loro proprietà di isolamento termico.

In ogni caso, questi materiali noti, grazie alla loro morfologia, sono in grado di dissipare energia meccanica a seguito della deformazione o della rottura della loro struttura, e risultano quindi adatti all'applicazione nel settore degli

imballaggi, e per l'impiego come materiali di protezione contro gli urti.

Nelle composizioni utilizzate per la produzione delle schiume fenoliche o poliuretatiche sono spesso impiegati solventi organici bassobollenti, ovvero con basso punto d'ebollizione (tipicamente compreso fra 30 e 80°C), i quali solventi evaporano a causa del calore che può essere fornito dall'esterno per raggiungere l'energia d'attivazione della reazione di polimerizzazione, oppure che proviene dall'esotermia stessa della reazione. L'evaporazione di questi solventi bassobollenti dà luogo alla formazione della struttura alveolare della schiuma. I solventi comunemente impiegati possono ad esempio consistere nelle seguenti sostanze, in forma pura o di miscela: etil-etero, pentano o isopentano. Molti di questi solventi sono ritenuti pericolosi essendo altamente infiammabili, e sarebbe conveniente eliminarli per rimuovere un fattore di pericolo del relativo procedimento.

In alternativa alla tecnologia che impiega solventi bassobollenti, sono descritti nella letteratura materiali espansi ottenuti da resine

fenoliche, che utilizzano sostanze che si possono decomporre a causa del calore o a causa dell'ambiente di reazione acido.

La presente invenzione riguarda una composizione a base di tannini vegetali, quindi a base di sostanze di origine naturale, per la produzione di un materiale espanso.

Sono già noti materiali espansi o schiumosi derivati da prodotti naturali, quali le schiume a base di tannini vegetali (flavonoidi) che consistono in piccole molecole poli-fenoliche estratte da varie specie vegetali, principalmente idrosolubili. Questi materiali espansi a base di tannini possono sostituire le schiume fenolo-formaldeide nella maggior parte delle applicazioni, perchè presentano proprietà e prestazioni analoghe.

Queste schiume di origine naturale presentano anche il vantaggio di essere eco-compatibili, poiché i tannini vegetali combinano alta reattività e basso costo con un carattere di rinnovabilità.

Le schiume solide a base di tannini vegetali finora note vengono preparate ad esempio mediante una tecnologia che prevede l'uso di una composizione di tannini condensati, alcol

furfurilico, formaldeide e dietiletere in un mezzo acquoso, e il loro indurimento si ottiene con l'aggiunta di un catalizzatore acido, ad esempio acido para-toluen-solfonico (p-TSA).

L'aggiunta di p-TSA, dà luogo a varie reazioni fra i componenti della composizione, come l'auto-condensazione dell'alcol furfurilico, la condensazione dell'alcol furfurilico con i flavonoidi, e la condensazione dei flavonoidi che hanno già reagito con la formaldeide. Queste reazioni, tutte esotermiche, avvengono simultaneamente e provocano l'ebollizione del dietiletere che, evaporando, causa l'espansione della schiuma contemporaneamente al verificarsi del processo di reticolazione (G. Tondi et A. Pizzi, *Industrial Crops and Products*, 29, 2009, 356-363).

Questa composizione nota e il relativo procedimento per ottenere schiume solide, comportano tuttavia la presenza di due aspetti che possono essere fonte di problemi.

Da una parte, l'uso di formaldeide in qualità di agente di reticolazione, è ritenuto critico in quanto sono noti i suoi effetti nocivi sulla salute umana, tanto che essa è classificata come agente

sospetto cancerogenico dalla UE e come agente cancerogenico dal IARC (International Agency for Research on Cancer, ente dell'OMS - World Health Organization). Inoltre, la presenza di residui di formaldeide nel materiale schiumoso sono particolarmente sgraditi nel caso del suo impiego come materiale isolante, tenuto conto del fatto che le normative nazionali e internazionali sui materiali di costruzione tendono ad essere sempre più restrittive nei confronti della presenza e delle emissioni di formaldeide.

L'impiego di dietiletere come agente espandente, che è un solvente altamente volatile e combustibile, costituisce un ulteriore problema.

In particolare, l'invenzione riguarda una composizione per la fabbricazione di un materiale espanso, o schiuma, a base di tannini vegetali, del tipo definito nel preambolo della rivendicazione 1.

Una tale composizione, nota dalla domanda di brevetto italiana T02011A000656 a nome delle stesse Richiedenti, è utilizzabile in un procedimento per ottenere una schiuma solida a base di tannini flavonoidi. Questa composizione nota consiste in una miscela di tannini con alcol furfurilico, un

agente espandente costituito da un solvente organico altamente volatile, e da un catalizzatore, ed è totalmente esente da formaldeide o da altre aldeidi, per cui non possono esservi emissioni di tali sostanze dal prodotto finito. La composizione e il relativo procedimento implicano tuttavia l'impiego di composti come il pentano, l'esano e/o relativi isomeri, eteri derivati dal petrolio come il dietilere, che sono solventi con basso punto di ebollizione (30-60°C), che diventano volatili nel corso delle reazioni esotermiche di polimerizzazione, provocando così la formazione della schiuma. Questi composti possono determinare effetti nocivi sulla salute degli operatori e per l'ambiente.

In vista degli inconvenienti della tecnica nota qui sopra menzionata, l'invenzione si prefigge lo scopo di proporre una nuova composizione a base di tannini che non comporti l'impiego di formaldeide né di solventi organici bassobollenti, e che permetta di ottenere un materiale alveolare o schiumoso di basso costo, alte prestazioni e di carattere ecologico, utilizzabile per molteplici applicazioni.

Questo scopo viene raggiunto secondo l'invenzione, da una composizione come definita nelle rivendicazioni 1 a 10.

Grazie al fatto che fatto che la composizione dell'invenzione contiene una quantità di acqua non maggiore del 15% in peso della composizione, e dal fatto che include una sostanza atta a sviluppare un gas con funzione di agente espandente, tale sostanza essendo utilizzata secondo una quantità non maggiore del 10% in peso della composizione, la composizione essendo totalmente priva di formaldeide e di solventi organici bassobollenti, è possibile ottenere un materiale espanso solido insolubile e non-fondibile che deriva da risorse naturali. Poiché la composizione e il materiale espanso da essa ottenibile sono totalmente privi sia di formaldeide, sia di solventi organici a basso punto di ebollizione, essi non comportano gli inconvenienti della tecnica nota.

Secondo una caratteristica preferita dell'invenzione, la sostanza atta a sviluppare un gas con funzione di agente espandente è un isocianato, utilizzato secondo una quantità minore dell'1% in peso della composizione.

Grazie a tale caratteristica, l'isocianato reagisce con l'acqua della composizione e con il tannino liberando diossido di carbonio (CO₂) che costituisce l'agente espandente, ed inoltre favorisce l'ottenimento di una schiuma con elevate proprietà di resistenza meccanica.

L'invenzione ha anche per oggetto un materiale espanso ottenibile dalla suddetta composizione, come definito nella rivendicazione 11.

In particolare, il materiale espanso dell'invenzione risulta leggero, poco costoso, facile da produrre, con caratteristiche di buona resistenza meccanica, di alta resistenza al fuoco e di ridotta conducibilità termica. In particolare, il materiale espanso secondo l'invenzione presenta le caratteristiche richieste per la sua applicazione in diversi settori industriali, nei trasporti e nelle costruzioni.

Forma inoltre oggetto dell'invenzione un procedimento di produzione di un materiale espanso a base di tannini vegetali, a partire dalla suddetta composizione.

Ulteriori caratteristiche e vantaggi dell'invenzione risulteranno più chiari dalla

descrizione dettagliata che segue, fornita a titolo d'esempio non limitativo e riferita alle figure annesse in cui:

- la figura 1 è un grafico che rappresenta curve dei valori di resistenza alla compressione ottenuti sperimentalmente per due campioni di materiali espansi secondo la tecnica nota (STD e SF) e di un campione di materiale espanso secondo l'invenzione (M1),

- la figura 2 è un grafico che rappresenta curve dei valori ottenuti sperimentalmente per l'evoluzione nel tempo della temperatura, durante la preparazione dei materiali espansi STD, SF e M1,

- la figura 3 è un grafico che rappresenta curve dei valori ottenuti sperimentalmente per l'evoluzione nel tempo della pressione, durante la preparazione delle schiume STD, SF e M1,

- la figura 4 è un grafico che rappresenta curve caratteristiche dei valori ottenuti sperimentalmente per la velocità di espansione e per la polarizzazione dielettrica in funzione del tempo, durante la preparazione del materiale espanso STD,

- la figura 5 è un grafico che rappresenta

curve caratteristiche dei valori ottenuti sperimentalmente per la velocità di espansione e per la polarizzazione dielettrica in funzione del tempo, durante la preparazione del materiale espanso SF, e

- la figura 6 è un grafico che rappresenta curve caratteristiche dei valori ottenuti sperimentalmente per la velocità di espansione e per la polarizzazione dielettrica in funzione del tempo, durante la preparazione del materiale espanso M1.

Un materiale espanso secondo la presente invenzione viene preparato a partire da tannini condensati poliflavonoidici, alcol furfurilico, acqua, un catalizzatore, una sostanza atta a sviluppare un gas con funzione di agente espandente, convenientemente un isocianato in piccole quantità, ed eventualmente uno o più additivi.

I tannini vegetali utilizzati sono tannini condensati poliflavonoidici, ad esempio tannini estratti dalla corteccia di Mimosa, (Acacia mearnsii, Acacia mollissima, Acacia mangium), dal legno di Quebracho (Schinopsis lorenzii, Schinopsis

balansae), dalla corteccia di pino (Pinus pinaster), di Abete (Picea abies), di Pecan (Carya illinoensis), nonché da legno e corteccia di Catechu (Acacia catechu).

I tannini vengono impiegati sotto forma di polvere, secondo una quantità compresa tra il 40 e il 50% in peso della composizione.

L'alcol furfurilico è un prodotto di origine naturale ottenuto mediante riduzione catalitica con idrogeno del furfurale, che si ottiene dall'idrolisi acida di zuccheri e di scarti delle lavorazioni agricole. L'alcol furfurilico è utilizzato nella composizione dell'invenzione in una proporzione tale da permettere di ottenere un materiale espanso che sia totalmente esente da formaldeide. In particolare, viene utilizzata una quantità di alcol furfurilico maggiore del 15% in peso della composizione.

La composizione comprende anche una sostanza atta a sviluppare un gas con funzione di agente espandente, tipicamente utilizzata in una quantità relativamente piccola, e comunque non maggiore del 10% in peso della composizione. Preferibilmente tale sostanza consiste in un isocianato. In

alternativa, esso potrebbe essere sostituito almeno parzialmente da altre sostanze in grado di sviluppare gas a seguito della temperatura della reazione o dell'acidità richiesta per catalizzare la reazione, quali il nitrito di ammonio o il bicarbonato di sodio, come noto dalla letteratura relativa ad altri materiali espansi.

Nel caso preferito dell'impiego di isocianato, questo è utilizzato sotto forma di isocianato monomero, polimerico o modificato, ad esempio metilen-difenil-diisocianato (MDI) o difenilmetan-diisocianato-polimerico (PMDI), oppure di una loro combinazione, secondo una quantità generalmente inferiore all'1% in peso della composizione.

L'impiego di isocianato in piccole dosi ha vari effetti sulla formazione del materiale espanso e sulle caratteristiche del prodotto ottenuto. In primo luogo, permette di liberare diossido di carbonio (CO_2) nel corso della fase di polimerizzazione del materiale espanso, che funge da agente espandente a seguito della sua reazione con l'acqua e con il tannino della composizione, e rende quindi possibile evitare l'uso di solventi bassobollenti.

Inoltre, l'isocianato accresce la capacità della reazione di liberare calore, ovvero di essere esotermica, ottimizzando la fase di polimerizzazione.

Grazie alla presenza dell'isocianato, le proprietà meccaniche del materiale espanso ottenuto risultano migliorate. Infatti, l'isocianato reagisce con i gruppi $-CH_2OH$ e $=CHOH$ formati nei tannini per reazione con l'alcol furfurilico, e con i gruppi $-CH_2OH$ residui dell'alcol furfurilico e dei suoi oligomeri, per cui i gruppi uretani che si formano durante la costituzione della resina espansa sono più elastici, il che permette di ottenere una distribuzione migliore delle tensioni meccaniche nel volume del materiale polimerico espanso ottenuto.

Come catalizzatore viene utilizzato un acido, allo scopo d'innescare reazioni chimiche di policondensazione. L'acido può essere, ad esempio, acido para-toluensolfonico (p-TSA), acido fosforico oppure acido tricloroacetico. Convenientemente, il catalizzatore è una soluzione acquosa al 65% in peso di p-TSA, utilizzata secondo una quantità inferiore al 20% in peso della composizione. In

alternativa o in aggiunta all'acqua, il catalizzatore può essere disciolto in glicerina o altri alcoli o polialcoli.

Alla composizione viene aggiunta acqua secondo una proporzione in peso fino al 15% della composizione, oltre alle piccole percentuali d'acqua già presenti nel tannino e negli altri reattivi.

La composizione così definita che, come detto sopra, comprende principalmente tannini, alcol furfurilico, acqua, un catalizzatore e piccole quantità di una sostanza atta a sviluppare un gas con funzione di agente espandente, convenientemente un isocianato, consente di ottenere una schiuma solida che deriva per circa il 90% da risorse naturali disponibili e rinnovabili, diversamente da quanto avviene nei materiali espansi comunemente utilizzati, nei quali vengono ampiamente utilizzati prodotti derivati dall'industria petrolchimica, quindi di origine non naturale.

Possono essere aggiunti alla composizione uno o più additivi, secondo una proporzione variabile fino al 10% in peso.

Questi additivi possono comprendere, a titolo

di esempio non limitativo:

- agenti emulsionanti, disperdenti, surfattanti, ad esempio olio di ricino etossilato, polietilenglicoli, allo scopo di migliorare l'omogeneità della composizione, che agiscono come stabilizzanti durante il processo di formazione del materiale espanso, migliorandone anche la bagnabilità in acqua;
 - agenti plastificanti, allo scopo di diminuire la friabilità del materiale espanso ottenuto;
 - agenti d'accrescimento della resistenza al fuoco e di riduzione del tempo di auto-estinzione, quali acido borico, acido fosforico, o loro miscele e derivati;
 - nanoparticelle con funzione di filler per aumentare la resistenza meccanica del materiale espanso,
- o una loro qualunque combinazione.

Inoltre, possono essere impiegati altri agenti di polimerizzazione (curing agents) come, ad esempio, gliossale, esamina, acetaldeide, propionaldeide, butirraldeide, furaldeide.

Il gas liberato durante la reazione, che costituisce l'agente espandente, è tipicamente

diossido di carbonio generato dalla reazione dell'isocianato con l'acqua e con il tannino presenti nella composizione, per cui non è richiesto l'uso di composti altamente volatili in qualità di agenti espandenti, come era invece necessario per i materiali espansi della tecnica nota.

Il procedimento di preparazione del materiale espanso comprende, a titolo d'esempio, la preparazione iniziale di una miscela omogeneizzata che, come esposto in maggiore dettaglio nell'esempio che segue, include i tannini, l'alcol furfurilico, l'acqua e gli eventuali additivi. Successivamente, si aggiunge alla miscela la sostanza atta a sviluppare un gas con funzione di agente espandente, ad esempio un isocianato, e si esegue una nuova fase di omogeneizzazione, dopo di che viene aggiunto alla miscela ottenuta il catalizzatore.

Il procedimento può essere automatizzato in modo da controllare la dosatura dei singoli componenti della composizione, nonché i tempi e le temperature delle varie fasi.

L'invenzione viene illustrata in maggiore

dettaglio con riferimento all'esempio seguente, di una composizione e di un procedimento per l'ottenimento di un materiale espanso a base di tannini.

Esempio 1

Nella seguente Tabella 1 sono indicate le composizioni di alcuni materiali espansi a base di tannini, allo scopo di eseguire un loro confronto. In particolare, i materiali espansi denominati STD e SF sono stati ottenuti da una composizione e per mezzo di un procedimento tradizionali che impiegano solventi altamente volatili, mentre i materiali espansi denominati M1, M2 e M3 sono stati ottenuti a partire da composizioni e mediante un procedimento secondo l'invenzione. Ai fini dell'esempio, come catalizzatore, nelle varie composizioni, è stato utilizzato acido para-toluen-solfonico (p-TSA) secondo una quantità fissa di una soluzione acquosa, tipicamente del 65% in peso, nonostante possano essere utilizzati anche gli altri catalizzatori acidi sopra riferiti, e tutti i materiali ottenuti comprendono la medesima quantità di tannino e di acqua.

Mentre i materiali espansi M1, M2 e M3 sono

totalmente esenti da formaldeide e da solventi volatili, entrambi i materiali STD e SF comprendono dietiletere, e il solo materiale STD comprende sia dietiletere sia formaldeide.

Tabella 1 - *Composizione di materiali espansi a base di tannini*

Formulazione	STD	SF	M1	M2	M3
Tannino (g)	30	30	30	30	30
p-TSA (65%) (g)	11	11	11	11	11
Alcol furfurilico (g)	10.5	21	21	21	21
Formaldeide (g)	7.4	-	-	-	-
Dietiletere (g)	3	3	-	-	-
Acqua (g)	6	6	6	6	6
pMDI (g)	-	-	0.4	0.4	0.4
PEG400 (g)	-	-	-	0.6	-
Propilenglicole-metiletere	-	-	-	-	0.6

L'ottenimento dei materiali M1, M2 e M3, avviene secondo il procedimento esposto di seguito.

La quantità di tannino dosata viene aggiunta gradualmente, sotto agitazione meccanica, ad una miscela di alcol furfurilico, acqua ed eventuali additivi. Dopo aver agitato energicamente la

miscela fino a ottenere la sua completa omogeneità, la quale risulta poi stabile nel tempo a varie condizioni ambientali, il che ne permette il trasporto come intermedio. A questa miscela poi, al momento dell'uso, l'isocianato, e si agita nuovamente fino alla completa omogeneità. Viene quindi aggiunto il catalizzatore p-TSA, e si mantiene l'agitazione per un tempo necessario ad omogeneizzarlo alla massa, dopo di che la miscela ottenuta viene trasferita in un recipiente con funzione di stampo, allo scopo di ottenere una forma desiderata del materiale espanso.

Dopo un tempo d'induzione, che alla temperatura ambiente è di circa 110-120 secondi, in funzione della composizione utilizzata, inizia l'espansione della composizione.

Nella preparazione delle schiume SF e STD è stato utilizzato un procedimento simile, in cui è stato aggiunto dietiletere subito prima del catalizzatore. La formaldeide, nel caso della formulazione STD, è stata aggiunta insieme all'alcol furfurilico.

Analisi dei campioni dei materiali ottenuti

I materiali espansi ottenuti sono stati

tagliati in pezzi di dimensioni note in modo da ottenere campioni adatti ad essere esaminati e confrontati, nonché per determinare la loro densità apparente.

Dall'esame dei campioni ottenuti, si può notare che tutti presentano una struttura di aspetto omogeneo, esente da difetti apparenti. L'aggiunta di piccole quantità di PEG400 o di altri glicoli eteri come emulsionanti o disperdenti, migliora la miscelazione dei componenti della composizione dell'invenzione, poiché ne riduce la viscosità (materiali M2 e M3). Le proporzioni del resto dei reattivi è regolata finemente così da ottenere una composizione equilibrata.

La conducibilità termica dei campioni è stata determinata a temperatura ambiente mediante il metodo transitorio denominato Transient Plane Source (TPS, Hot Disk TPS 2500). La resistenza alla compressione è stata valutata attraverso uno strumento di valutazione universale INSTRON 5944 applicando una velocità di traslazione o di spostamento di 2 mm/min.

L'evoluzione dei parametri fisici nel corso della formazione delle schiume è stata studiata

preparando le stesse composizioni della Tabella 1 in un sistema FOAMAT modello 281, allo scopo di valutare contemporaneamente la velocità d'espansione, la velocità di polimerizzazione, la pressione, e la temperatura, durante tutto il processo.

Risultati sperimentali

I risultati ottenuti dai campioni di materiali espansi aventi le composizioni indicate nella Tabella 1, sono riportati nella seguente Tabella 2.

Tabella 2 - Caratterizzazione dei campioni STD, SF, M1, M2 e M3

	STD	SF	M1	M2	M3
Densità apparente (g/cm ³)	0.062	0.055	0.070	0.075	0.068
Conducibilità termica (W/mK)	0.049	0.043	0.044	0.044	0.042

Tutte le schiume ottenute sono leggere, poiché la loro densità apparente è inferiore a 1 g/cm³. Le composizioni M1, M2, M3 secondo l'invenzione presentano una conducibilità termica simile a quella della schiuma SF (senza formaldeide, e includente il dietilene), e inferiore a quella determinata per il campione STD (con formaldeide e

dietiletere).

Si può quindi concludere che le nuove composizioni dell'invenzione, prive di formaldeide e di agenti schiumanti bassobollenti, permettono di ottenere un materiale con buone proprietà di isolamento termico.

Qui di seguito sono riportati alcuni commenti sulle caratteristiche del solo campione M1, i campioni M2 e M3 essendo molto simili ad esso.

Le caratteristiche ottenute dalle prove di compressione eseguite sui campioni delle schiume STD, SF e M1, sono rappresentate nella Figura 1.

Il materiale STD (con formaldeide e dietiletere) risulta fragile e rigido, mentre le schiume SF e M1 (prive di formaldeide) presentano un modulo elastico significativamente inferiore e sono pertanto più elastiche, e non si fratturano facilmente. Infatti, è noto che la formaldeide tende ad immobilizzare le molecole di tannino durante le reazioni di cross-linking, il che determina una polimerizzazione incompleta e la formazione di un reticolo polimerico fragile. Quindi, l'assenza di formaldeide permette di ottenere catene polimeriche molto più flessibili.

Confrontando le curve di resistenza alla compressione della Figura 1, si nota che la schiuma M1 (senza formaldeide e senza etere) è più elastica e resistente della schiuma SF (senza formaldeide e con dietiletere), il che rappresenta un notevole miglioramento rispetto alle schiume al tannino senza formaldeide finora note. Il comportamento della schiuma M1 sottoposta a compressione è conseguenza dalla reazione dell'isocianato aggiunto alla composizione dell'invenzione, con i gruppi -CH₂OH dell'alcol furfurilico e con quelli generati dal tannino. Gli uretani formati a seguito della reazione migliorano le proprietà meccaniche della schiuma, che risulta più elastica, e consentono una migliore distribuzione delle tensioni meccaniche nel materiale espanso.

Le figure 2 e 3 riportano rispettivamente le curve della temperatura e della pressione misurate durante la formazione delle schiume STD, SF e M1, mentre le figure 4 a 6 illustrano la velocità di espansione e la polarizzazione dielettrica misurate per i campioni STD, SF e M1, rispettivamente.

In generale, le curve delle figure 2 a 6 evidenziano che i parametri fisici della schiuma M1

dell'invenzione evolvono diversamente da quelli delle schiume note STD e SF che contengono formaldeide e/o solventi volatili.

Si nota infatti (figura 2) che la temperatura massima (102°C) raggiunta dalla composizione M1 dell'invenzione, è superiore alla temperatura massima ottenuta per le composizioni SF e STD (minore di 90°C). Ciò consegue dall'impiego dell'isocianato nel campione M1, grazie a cui la reazione esotermica consente di aumentare la temperatura del sistema, ottimizzando il processo di reticolazione. Inoltre, come già detto, l'impiego dell'isocianato consente di produrre la CO₂ necessaria alla formazione del materiale espanso.

Nel caso della composizione M1 dell'invenzione si ottiene un picco di pressione, a circa 190 secondi (figura 3), che è significativamente inferiore di quello che si registra per il campione STD (a circa 80 secondi). L'uso di formaldeide e di solventi volatili nel campione STD comporta un aumento considerevole della pressione, a seguito della quale la sua struttura risulta più fragile. L'aumento di pressione nella composizione SF è

simile a quella che si verifica per la composizione del materiale M1. La composizione M1, priva di solventi bassobollenti, presenta un aumento graduale della pressione a partire da circa 340 secondi, corrispondente alla fase di polimerizzazione della schiuma (vedere anche il profilo della polarizzazione dielettrica della figura 6). L'aumento progressivo della pressione della composizione del campione M1 è conseguenza della presenza di CO₂ che si libera durante la reazione dell'isocianato con l'acqua della composizione durante la reticolazione, e che permette uno sviluppo di una maggiore porosità nel materiale, senza comportare né un collasso né una rottura della sua struttura.

I profili della velocità di espansione (calcolata in funzione dell'aumento dell'altezza della schiuma) e della polarizzazione dielettrica, misurati durante la preparazione dei campioni STD, SF e M1, rispettivamente, sono riportati nelle figure 4, 5 e 6. L'entità della polarizzazione dielettrica fornisce un'informazione sullo stato di polimerizzazione della relativa composizione. Questo parametro diminuisce drasticamente quando

inizia la reticolazione, e progredisce fino allo stato d'immobilizzazione delle molecole.

Nel caso dei campioni STD e SF, la reticolazione avviene più lentamente rispetto all'espansione, mentre per la composizione M1 i due processi avvengono in modo praticamente simultaneo. Ciò costituisce un aspetto vantaggioso dal punto di vista delle proprietà meccaniche del materiale ottenuto con il procedimento.

In conclusione, la composizione e il procedimento di produzione di materiali espansi o alveolari a base di tannini secondo la presente invenzione sono vantaggiosi rispetto a quelli finora noti. Essi, infatti, sono di carattere ecologico perchè non comportano l'impiego né di formaldeide né di solventi bassobollenti, e sono derivati da materie prime rinnovabili ampiamente disponibili. I materiali espansi ottenuti dalla composizione e dal procedimento dell'invenzione presentano buone proprietà isolanti e un'ottima resistenza meccanica, insieme a caratteristiche di non infiammabilità, di basso impatto ambientale, e possono essere prodotti con un basso costo.

RIVENDICAZIONI

1. Composizione per la fabbricazione di un materiale espanso comprende tannini flavonoidici, principalmente del tipo prorobineditinidinico e/o profisetinidinico, secondo una quantità in peso compresa generalmente fra il 40% e il 50% in peso della composizione, alcol furfurilico secondo una quantità maggiore del 15% in peso della composizione e un catalizzatore acido,

caratterizzata dal fatto che contiene una quantità di acqua non maggiore del 15% in peso della composizione, e dal fatto che include una sostanza atta a sviluppare un gas con funzione di agente espandente, tale sostanza essendo utilizzata secondo una quantità non maggiore del 10% in peso della composizione, la composizione essendo totalmente priva di formaldeide e di solventi organici bassobollenti.

2. Composizione secondo la rivendicazione 1, caratterizzata dal fatto che detta sostanza atta a sviluppare un gas con funzione di agente espandente è un isocianato, utilizzato secondo una quantità minore dell'1% in peso della composizione.

3. Composizione secondo la rivendicazione 2,

caratterizzata dal fatto che detto isocianato consiste in metilen-difenil-diisocianato (MDI) o in difenilmetan-diisocianato-polimerico (PMDI), o in una loro combinazione, e dal fatto che permette di liberare diossido di carbonio (CO₂) con funzione di agente espandente nel corso della fase di polimerizzazione del materiale espanso.

4. Composizione secondo una qualsiasi delle rivendicazioni 1 a 3, caratterizzata dal fatto che detto catalizzatore è un acido quale acido p-toluensolfonico, acido fosforico, o acido tricloroacetico.

5. Composizione secondo la rivendicazione 4, caratterizzata dal fatto che detto catalizzatore acido è utilizzato in una soluzione che corrisponde ad una quantità minore del 20% in peso della composizione.

6. Composizione secondo la rivendicazione 5, caratterizzata dal fatto che detta soluzione è una soluzione acquosa in cui il catalizzatore acido corrisponde a circa il 65% in peso della soluzione.

7. Composizione secondo la rivendicazione 5, caratterizzata dal fatto che il catalizzatore acido di detta soluzione è disciolto in glicerina oppure

in alcoli o polialcoli.

8. Composizione secondo una qualsiasi delle rivendicazioni 1 a 7, caratterizzata dal fatto che contiene additivi quali agenti emulsionanti, disperdenti, surfattanti, e/o agenti d'accrescimento della resistenza al fuoco e di riduzione dell'auto-estinzione e/o nanoparticelle con funzione di filler, e/o agenti di polimerizzazione, secondo una quantità complessiva non maggiore del 10% in peso della composizione.

9. Composizione secondo la rivendicazione 8, caratterizzata dal fatto che detti agenti d'accrescimento della resistenza al fuoco e di riduzione dell'auto-estinzione consistono in acido borico e/o acido fosforico o in loro derivati, o in una loro combinazione.

10. Composizione secondo la rivendicazione 8, caratterizzata dal fatto che detti agenti di polimerizzazione consistono in gliossale, esamina, acetaldeide, propionaldeide, butirraldeide e/o furaldeide, o in una loro combinazione.

11. Materiale espanso organico a base di tannini, caratterizzato dal fatto che è ottenuto da una composizione secondo una qualsiasi delle

rivendicazioni 1 a 10.

12. Procedimento per la fabbricazione di un materiale espanso, caratterizzato dal fatto che comprende le fasi di:

- predisporre uno stampo di forma corrispondente a quella del prodotto da ottenere,
- preparare una miscela contenente quantità dosate di alcol furfurilico, acqua e tannini,
- eseguire una prima fase di omogeneizzazione,
- aggiungere alla miscela così ottenuta una sostanza atta a sviluppare un gas con funzione di agente espandente,
- eseguire una seconda fase di omogeneizzazione,
- aggiungere alla miscela un catalizzatore acido,
- eseguire una terza fase di omogeneizzazione,
- trasferire la miscela in detto stampo.

13. Procedimento secondo la rivendicazione 12, caratterizzato dal fatto che detta sostanza atta a sviluppare un gas con funzione di agente espandente è un isocianato, e dal fatto che detto isocianato viene aggiunto secondo una quantità non maggiore dell'1% in peso della miscela finale.

14. Procedimento secondo la rivendicazione 13,

caratterizzato dal fatto che detto isocianato consiste in metilen-difenil-diisocianato (MDI) o in difenilmetan-diisocianato-polimerico (PMDI), o in una loro combinazione.

15. Procedimento secondo una qualsiasi delle rivendicazioni 12 a 14, caratterizzato dal fatto che detti tannini sono tannini flavonoidici, principalmente del tipo prorobineditinidinico e/o profisetinidinico, sotto forma di una polvere secondo una quantità in peso compresa generalmente fra il 40% e il 50% in peso della miscela finale.

16. Procedimento secondo una qualsiasi delle rivendicazioni 12 a 15, caratterizzato dal fatto che include la fase di aggiungere alla miscela contenente l'alcol furfurilico e l'acqua, prima dell'aggiunta dei tannini alla miscela, quantità dosate di additivi, quali agenti emulsionanti, disperdenti, surfattanti, e/o agenti d'accrescimento della resistenza al fuoco e di riduzione dell'auto-estinzione, e/o nanoparticelle con funzione di filler, e/o agenti di polimerizzazione.

17. Procedimento secondo una qualsiasi delle rivendicazioni 12 a 16, caratterizzato dal fatto

che la quantità di alcol furfurilico è maggiore del 15% in peso della miscela finale, dal fatto che la quantità di acqua è non maggiore del 15% in peso della miscela finale.

18. Procedimento secondo una qualsiasi delle rivendicazioni 12 a 17, caratterizzato dal fatto che il catalizzatore acido consiste in acido p-toluensolfonico (p-TSA), acido fosforico acido tricloroacetico o una loro combinazione, preferibilmente in soluzione acquosa, di glicerina, di alcoli oppure di polialcoli.

RIASSUNTO

Una composizione per la fabbricazione di un materiale espanso comprende tannini flavonoidici, principalmente del tipo prorobineditinidinico e/o profisetinidinico, secondo una quantità in peso compresa generalmente fra il 40% e il 50% in peso della composizione, alcol furfurilico secondo una quantità maggiore del 15% in peso della composizione, ed un catalizzatore acido. La composizione contiene una quantità di acqua non maggiore del 15% in peso della composizione, ed include una sostanza atta a sviluppare un gas con funzione di agente espandente, quale un isocianato, secondo una quantità non maggiore del 10% in peso della composizione, preferibilmente minore dell'1% in peso, la composizione essendo totalmente priva di formaldeide e di solventi organici bassobollenti.

(Figura 1)

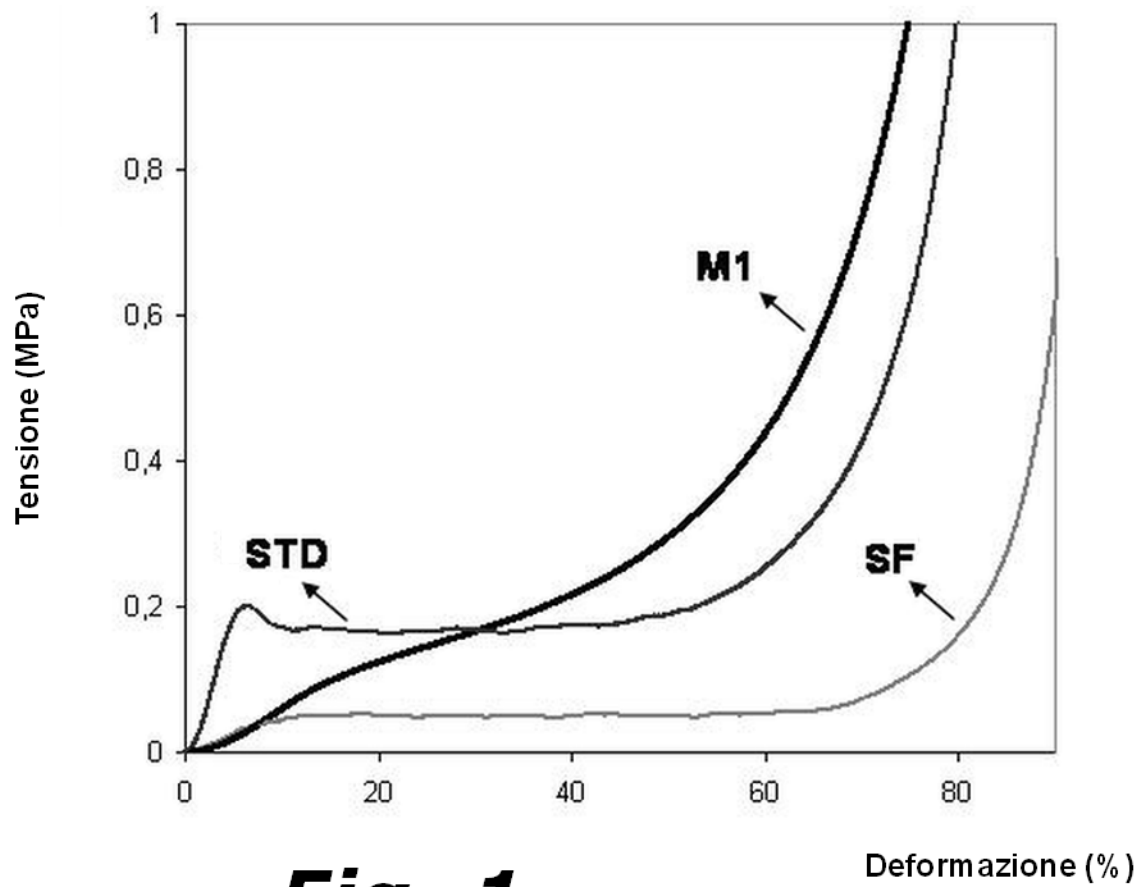
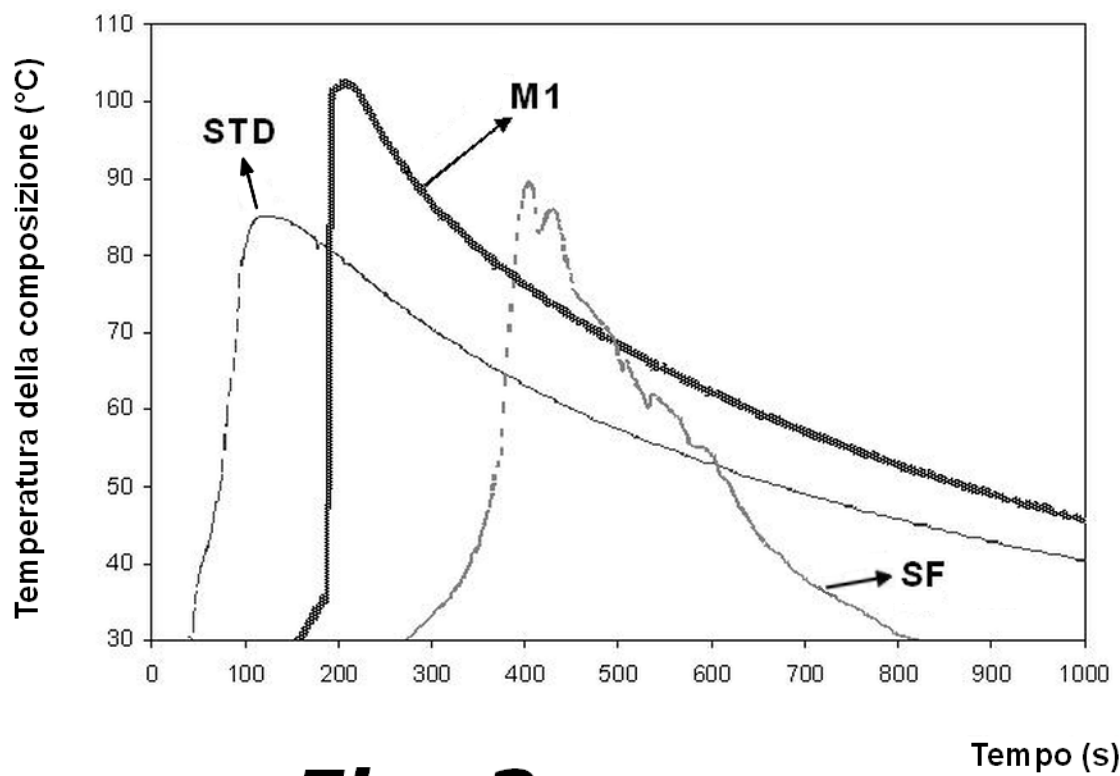
**Fig. 1****Fig. 2**

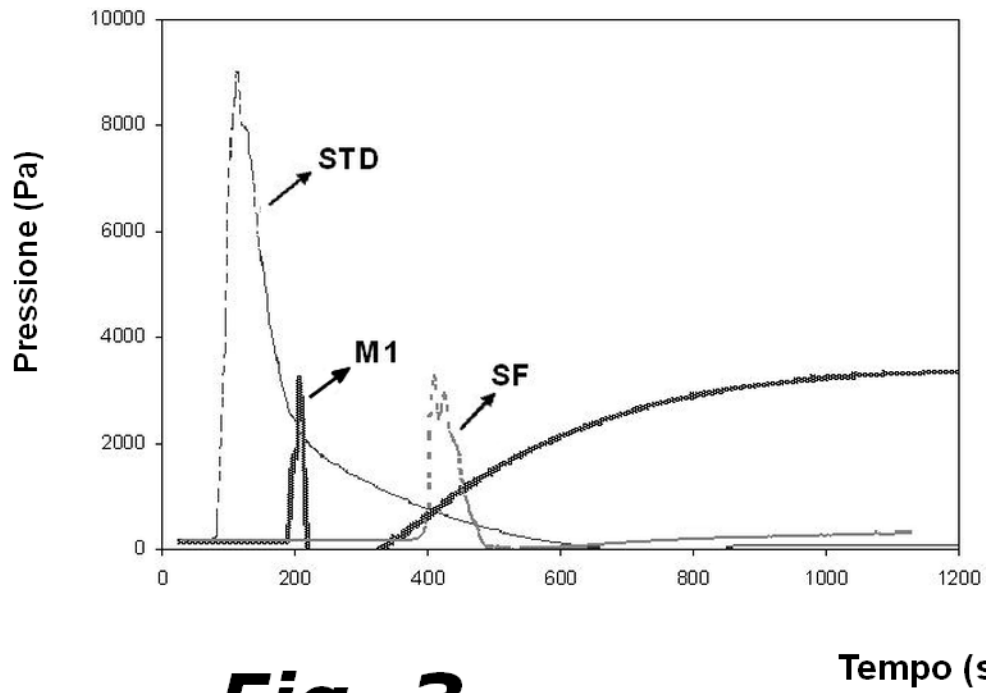
**Fig. 3**

Tempo (s)

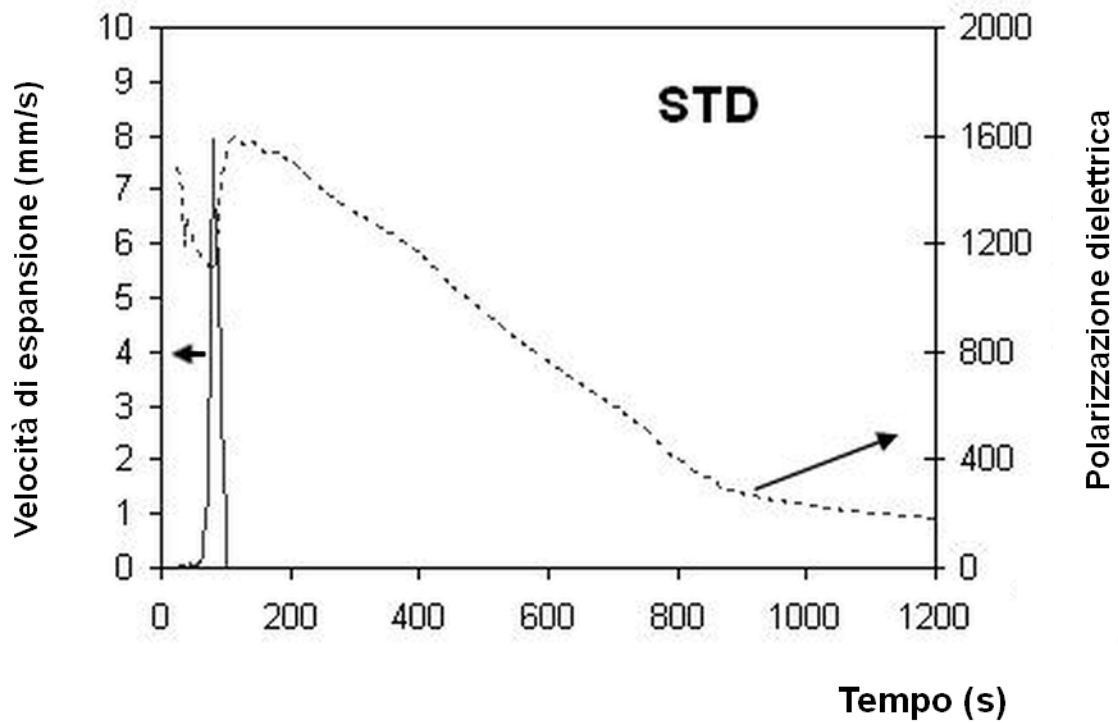
**Fig. 4**

Tempo (s)

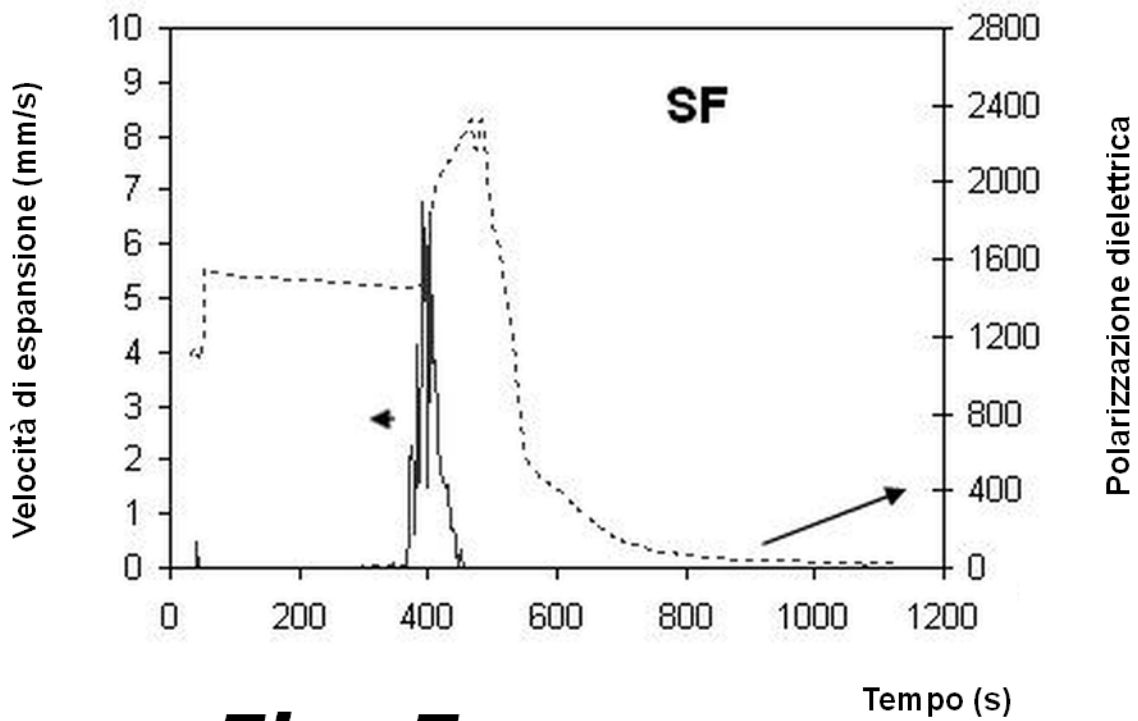
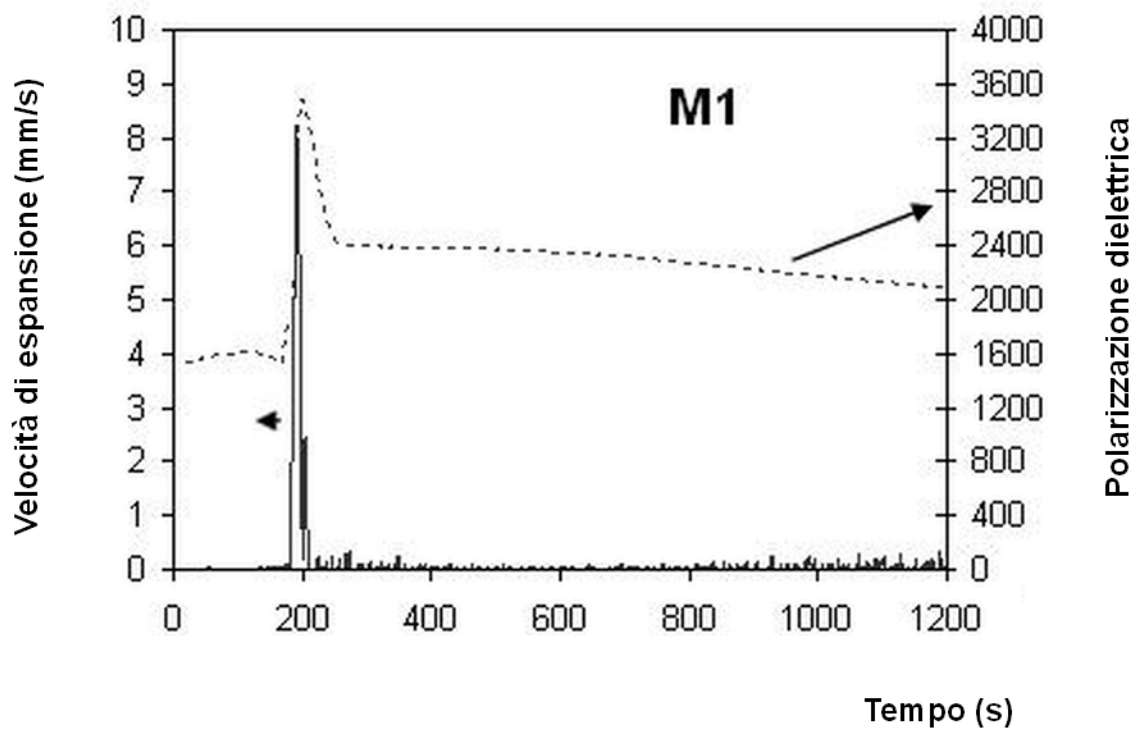
**Fig. 5****Fig. 6**

Mousses aux tanins et alcool furfurylique sans solvants organiques volatils et sans formaldéhyde.

Auteurs: M.C.Basso, S.Giovando, A.Pizzi, A.Celzard

Ind.Crops&Prods, 49 (2013) 17- 22

Les tanins de type prorobinétidine et profisétidine ont été utilisés pour préparer des mousses rigides aux tanins avec de l'alcool furfurylique auto-gonflant. Cette préparation ne nécessite ni l'utilisation d'agents gonflants organiques volatils, ni celle de formaldéhyde. Les mousses ainsi produites sont faites avec 98% de matériaux renouvelables et sont encore plus respectueuses de l'environnement. Elles présentent une isolation thermique et une résistance au feu comparables à celles de mousses classiques contenant des agents gonflants organiques et du formaldéhyde et de meilleures caractéristiques de déformation. La comparaison des courbes décrivant simultanément l'expansion, le durcissement, la température et la variation de pression en fonction du temps, a permis de montrer des différences dans les processus et dégager les paramètres importants selon les différentes formulations. Ce travail a conduit à l'optimisation des paramètres de durcissement impliqués et donc à l'optimisation de la formation des mousses. L'analyse par tomographie des mousses produites a permis de comprendre leurs comportements différents tels observés lors des essais mécaniques (Cf. courbes de contrainte-déformation en compression).

En résumé, les formulations de mousses dans lesquelles le formaldéhyde et les agents gonflants organiques très volatils ont été exclus, donnent des matériaux qui sont nettement plus respectueux de l'environnement. Ces nouvelles mousses ont également de bonnes propriétés d'isolation thermique et une meilleure résistance mécanique. Elles sont aussi non-inflammables, de faible coût et obtenues à partir de matières premières renouvelables comme les formulations antérieures.

M.C.BASSO, S.GIOVANDO, A.PIZZI, A.CELZARD, Tanin/furanic foams without blowing agents and formaldehyde, *Ind.Crops&Prods*, 49 (2013) 17- 22

Provided for non-commercial research and education use.
Not for reproduction, distribution or commercial use.

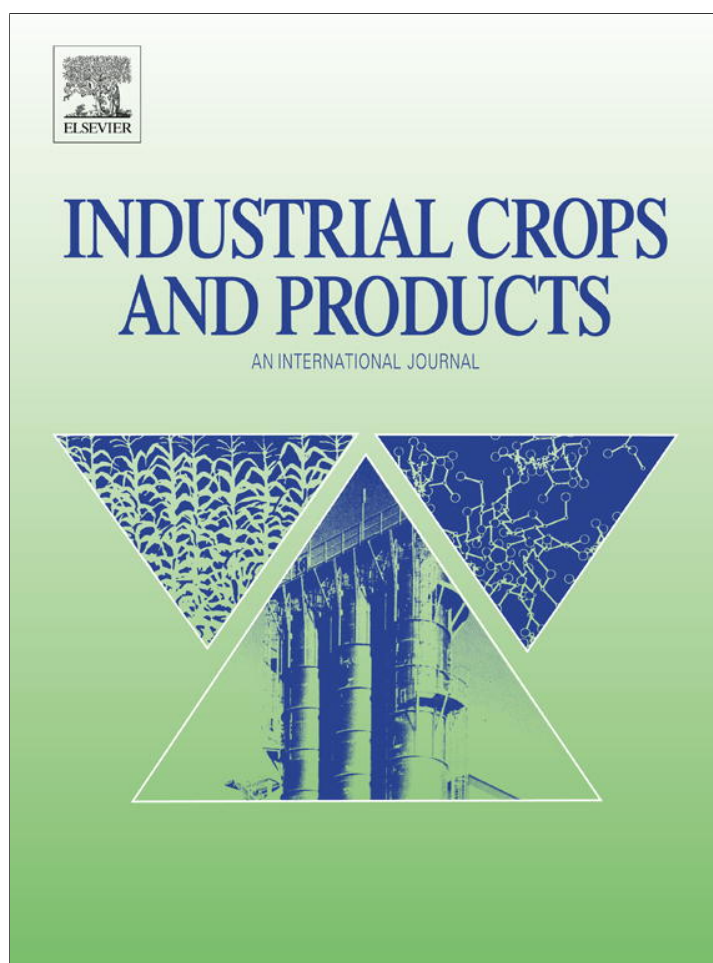

This article appeared in a journal published by Elsevier. The attached copy is furnished to the author for internal non-commercial research and education use, including for instruction at the authors institution and sharing with colleagues.

Other uses, including reproduction and distribution, or selling or licensing copies, or posting to personal, institutional or third party websites are prohibited.

In most cases authors are permitted to post their version of the article (e.g. in Word or Tex form) to their personal website or institutional repository. Authors requiring further information regarding Elsevier's archiving and manuscript policies are encouraged to visit:

<http://www.elsevier.com/authorsrights>

Contents lists available at [SciVerse ScienceDirect](http://www.sciencedirect.com)

Industrial Crops and Products

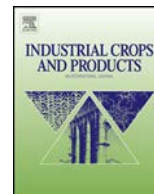
journal homepage: www.elsevier.com/locate/indcrop

Tannin/furanic foams without blowing agents and formaldehyde

M.C. Basso^{a,b}, S. Giovando^a, A. Pizzi^{c,d,*}, A. Celzard^e, V. Fierro^e^a Indunor, Cerrito 1066, Buenos Aires, Argentina^b Silva-Ledoga, S.Michele Mondovi, Italy^c LERMAB, University of Lorraine, Epinal, France^d King Abdulaziz University, Jeddah, Saudi Arabia^e IJL, University of Lorraine, Epinal, France

ARTICLE INFO

Article history:

Received 5 February 2013

Received in revised form 22 April 2013

Accepted 30 April 2013

Keywords:

Tannin

Foams

Without blowing agents

Without formaldehyde

Insulation foams

Floral foams

ABSTRACT

Prorobinetinidin/profisetinidin type tannins have been used to prepare self-blowing tannin/furfuryl alcohol foams that do not need either formaldehyde or volatile organic blowing agents to prepare rigid foams. The 98% renewable materials foams so produced were even more environment-friendly, they presented equal thermal insulation and fire resistance and presented better stress–strain characteristics than tannin/furanic foams containing formaldehyde and organic blowing agents. Comparison of curves describing the simultaneously-measured foams expansion, hardening, temperature and pressure variation as a function of time allowed to show the differences in process and foaming parameters engendered by the differences in formulation of the experimental and control foams and optimisation of the foaming and hardening parameters involved. Tomography of the foams and foam controls produced supported the different characteristics observed for these foams obtained by stress–strain curves in compression.

© 2013 Elsevier B.V. All rights reserved.

1. Introduction

Mimosa (*Acacia mearnsii* formerly *mollissima*, De Wildt) bark and quebracho (*Schinopsis lorentzii* and *Schinopsis balansae*) wood condensed tannins are commercial mixtures of predominantly prorobinetinidin and profisetinidin oligomers used mainly for leather tannins and for wood adhesives and resins (Pizzi, 1983).

Rigid foams based on the coreaction of this type of tannins with furfuryl alcohol, both opened cells and closed cells, have been known since 1994 (Meikleham and Pizzi, 1994). Considerable interest has been recently generated in these foams, their use and their characterisation due to their composition based predominantly (up to 98%) on renewable, environment-friendly raw materials, their great thermal and fire resistance, their lower cost and ease of preparation (Pizzi et al., 2008; Tondi and Pizzi, 2009; Tondi et al., 2009; Li et al., 2012a,b, 2013; Lacoste et al., 2013). Polyflavonoid tannins, which represents more than 55% of the foam, are vegetal products obtained by water extraction from the wood and bark of trees.

Around 20% of the final weight of the foam is constituted by furfuryl alcohol which is obtained throughout catalytic reduction of furfural (Nagaraja et al., 2003). Furfural is a natural derivative obtained by hydrolysis of the sugars from several agricultural crops (Aguilar et al., 2002).

These foams are prepared from a highly viscous liquid phase composed of a tannin-formaldehyde resin mixed with furfuryl alcohol, the latter used as a heat generating agent for both his self-polymerization reaction and for its reaction with the tannin under acid conditions. Expansion of this liquid mixture to a low density foam is obtained by simultaneous cross-linking of the resins mix and evaporation of a physical blowing agent of low boiling point.

Polymerisation is possible because tannins undergo rapidly reaction with aldehydes. In prorobinetinidin and profisetinidin dominated tannin extracts, the flavan-3-ols repeating units are linked mostly C4–C6 and sometime C4–C8. Such flavonoid units are repeated 2–11 times to produce a tannin of number average degree of polymerisation of 4–5 (Pasch et al., 2001). The C6 and C8 nucleophilic sites on the A-rings of the flavonoid repeating units are considerably more reactive toward aldehydes than those on the B-rings. For these tannins, the reactivity of the flavonoid A-rings is comparable, although slightly lower than that of resorcinol

* Corresponding author at: LERMAB, University of Lorraine, Epinal, France.

Tel.: +33 329296117.

E-mail address: antonio.pizzi@univ-lorraine.fr (A. Pizzi).

(Pizzi, 1983, 1994).

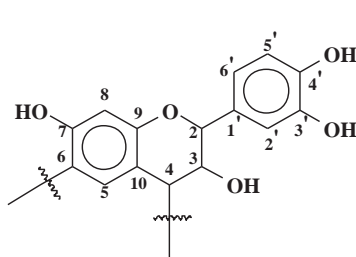

profisetinidin

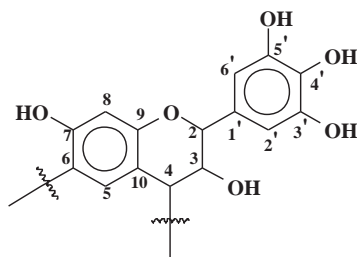

prorobinetindin

The chemical structure of these tannin–furanic foams has been investigated by MALDI-ToF and it has been seen that the network is constituted by several different copolymer chains of furans and formulated flavan-3-ols (Pizzi et al., 2008).

Recent work done on tannin-based rigid foams has given interesting information about properties such as water absorption, compression strength, fire resistance and chemical structure (Tondi and Pizzi, 2009).

As formaldehyde is now considered potentially carcinogenic tannin–furanic foam formulations without formaldehyde have been developed (Basso et al., 2011). These respond already to this potential health and environmental threat. The second environment and health threat is the presence in the formulation of the organic solvent/blowing agent considered essential to obtain such foams. To eliminate completely such health and environmental threat is not easy, the aldehyde giving higher cross-linking strength to the foam, and the blowing agents allowing foaming of the resin.

This paper then describes (i) the development of self-blowing tannin–furanic foams without any aldehyde and without any blowing agent being used, (ii) the characterisation of these materials as regards their mechanical and thermal properties and lastly (iii) the comparison of the properties of these foams to those of tannin–furanic foams with formaldehyde and organic solvent blowing agents.

2. Experimental

2.1. Tannin

Commercial tannin powder, sold under the name Mimosa OP and supplied by the company SilvaChimica (St. Michele Mondovi, Italy) has been used. Tannin was extracted industrially in Tanzania from the whole, dried, bark of 10-years old Mimosa trees (*Acacia mearnsii*, formerly *mollissima*, de Wild). Tannin contains more than 80% phenolic (flavonoid) materials, represented in Fig. 1, the remainder being water, amino and imino acid fractions (iminoacids being molecules containing both a >C=NH and a –COOH group), hydrocolloid gums and carbohydrates, in general broken pieces of hemicelluloses (Pizzi, 1983). In Mimosa tannin, prorobinetindin represents about 70% of the phenolic component. More details about degree of polymerization and average molecular weight of the oligomers have been given elsewhere (Pizzi, 1983; Pasch et al., 2001).

2.2. Foams preparation

Two experimental foam formulations containing neither formaldehyde nor volatile organic blowing agents were prepared according to the following procedure: an initial mixture of 21 g furfuryl alcohol, 6 g water and 30 g tannin extract powder was prepared under mechanical stirring for 20 s. A small proportion of polymeric 4,4'-diphenylmethane diisocyanate was then added (Table 1) and strongly stirred for approximately 15 s to ensure

homogeneous distribution in the mixture. Lastly 11 g of a water solution at 65% concentration of para-toluen sulphonic acid catalyst was added while continuing stirring for 20 s after its addition to the mixture. In the case of the M2 foam the initial mixture contained also 0.6 g of polyethylene glycol (PEG 400) to decrease the mix viscosity. The mixtures so prepared were then poured in containers to give to the finished foams the desired shape.

To compare these two foams two control foams were prepared according to the same procedure: (i) a foam formaldehyde-free but still containing 3 g diethyl ether as blowing agent (SF) and (ii) a control foam containing both formaldehyde and diethyl ether blowing agent (STD, Table 1) (Tondi et al., 2009). In the case of this latter control the formaldehyde was added together with the furfuryl alcohol. After an induction time varying in accordance with the composition between approximately 110 ad 120 s, the mixtures foamed and hardened. The foams so prepared were allowed to stabilise at

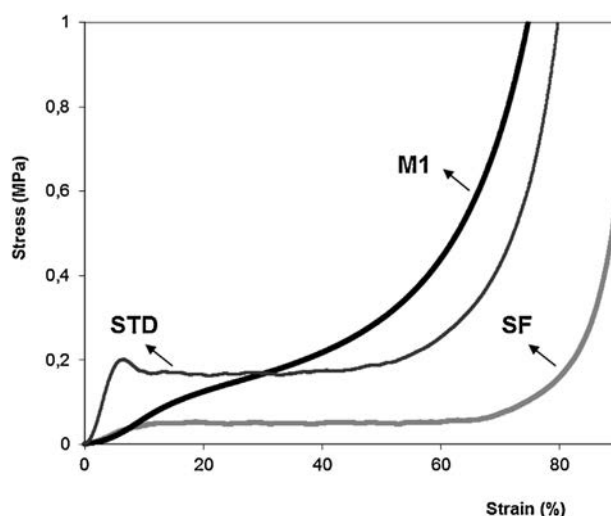

Fig. 1. Comparative mechanical resistance as illustrated by stress–strain curves of a standard foams (with formaldehyde and a blowing agent), of the SF foam (without formaldehyde but with a blowing agent) and of the experimental foam M1 without formaldehyde and without a blowing agent.

Table 1
Comparative composition of tannin foams.

Formulation	STD	SF	M1	M2
Tannin (g)	30	30	30	30
p-TSA (65%) (g)	11	11	11	11
Furfuryl alcohol (g)	10.5	21	21	21
Formaldehyde (g)	7.4	–	–	–
Diethyl ether (g)	3	3	–	–
Water (g)	6	6	6	6
pMDI (g)	–	–	0.4	0.4
PEG400 (g)	–	–	–	0.6

Table 2

Apparent density and thermal conductivity of STD, SF, M1 and M2 tannin foams.

	STD	SF	M1	M2
Apparent density (g/cm ³)	0.062 ± 0.006	0.055 ± 0.005	0.070 ± 0.005	0.075 ± 0.004
Thermal conductivity (W/mK)	0.049 ± 0.02	0.043 ± 0.02	0.044 ± 0.02	0.043 ± 0.02

ambient temperature for 72 h and then cut in specimens for testing. Each foam was prepared in eight replicates.

2.3. Foams characterization

All the foams were cut into parallelepipeds and weighed in order to measure their bulk density. All were homogeneous and flawless. Thermal conductivity was measured on three specimens of each of the eight replicates of each foam for a total of 24 measurements for each type of foam.

Thermal conductivity was measured at 20 °C by the transient plane source method (TPS, Hot Disk TPS 2500). The method is based on a transiently heated plane sensor, used both as a heat source and as a dynamic temperature sensor. It consists of an electrically conducting pattern in the shape of a double spiral, which has been etched out of a thin nickel foil and sandwiched between two thin sheets of Kapton. For one measurement, the plane sensor was fitted between two samples, each with a plane surface facing the sensor. The dimensions of the sample, compared to that of the sensor, were adequate for considering the sample as a semi-infinite medium: 3 × 3 × 1.5 cm³. The thermal conductivity was then calculated with the Hot Disk 6.1 software.

The resistance to compression was obtained with an Instron 4206 universal testing machine equipped with a 1 kN head. The compression was carried out at a constant load rate of 2.0 mm/min during which deformation and load were continuously recorded.

2.4. Foaming process characterization

The curves describing the expansion, hardening, temperature and pressure variation as a function of time for the STD, SF and M1 foams have been determined simultaneously with a FOAMAT apparatus Model 281 (Foamat Messtechnik GmbH, Karlsruhe, Germany). The different measuring sensors were controlled by the program MOUSSE version 3. For each foaming after mixture preparation, the mixture was poured in a suitable foaming chamber, namely a carton cylinder for each case, supplied with the equipment and placed on the metal plate with manometer of the equipment. The pressure generated by the expansion of the material on foaming was measured then by the force applied onto the metal plate. The temperature was measured simultaneously by a thermocouple immersed into the mixture. The hardening rate profile of the foams was measured simultaneously by a dielectric polarisation sensor composed of two comb-shaped electrodes disposed on a printed circuit in such a manner as to form a type of flat condenser. This was integrated to the pressure measuring device located on the metal plate at the bottom of the material under test. The blowing pressure ensured the contact between the foaming sample and the polarisation sensor, and consequently ensured the direct penetration of the electrical field.

The foam height during its expansion was constantly monitored by an ultrasound sensor placed over the carton cylinder opening. This functions according to the “pulse-echo” method. This means that foam height is determined at every instant by the time needed for the acoustic pulse to strike the surface of the expanding foam and to return to the sensor. The ultrasonic sensor is a membrane-type converter used as both acoustic transmitter and receptor.

2.5. Tomography

In this study, standard scaffold analysis was applied the following scaffold modules were used: SCAF, R-10, Version V1.0

The scaffolds were scanned by micro-computed tomography (microCT) using the following parameters: Energy 45 kVp; Intensity 88 μA; Integration time 200 ms; Frame averaging 2×; Nominal resolution 7.4 μm (isotropic). For image processing the measured data was filtered using a constrained Gaussian filter with finite filter support (1 voxel) and filter width (λ = 0.8). The images were then binarized to separate the object from the background using a global thresholding procedure. A component labeling algorithm was subsequently applied to remove all unconnected parts which typically arise from image noise. These final images were then analyzed with standard morphometric algorithms (Hildebrand and Ruegsegger, 1996; Odgaard, 1997; Odgaard and Gundersen, 1993). A centered volume of interest (VOI) was digitally extracted from the measured data. The VOI was selected to be a cuboid of 5 × 5 × 4.5 mm³ edge length (i.e. 672 × 672 × 606 voxels). Selecting a digital sub-volume reduces boundary artifacts that may occur from sample preparation. A three-dimensional representation of each scaffold was created.

3. Results and discussion

In Table 1 are shown the formulations of the different foams tested: a tannin foam control containing both formaldehyde and a very volatile organic solvent as blowing agent (STD) (Meikleham and Pizzi, 1994; Tondi and Pizzi, 2009), a tannin foam without formaldehyde but still containing a very volatile organic solvent as blowing agent (SF) (Basso et al., 2011) and two experimental tannin foams, M1 and M2, containing neither formaldehyde nor any blowing agent. The formulation of the foams presented was optimized until an equilibrium between the rates of expansion and of hardening was obtained. This was done to avoid either an excessively rapid or an excessively slow hardening rate, these in both cases leading respectively to either insufficient foam blowing or to collapse of the foam.

All the foam samples obtained presented homogeneous appearance, without defects. The addition of small doses of polyethylene glycol 400 (PEG400) or of other glycols or glycol ethers as emulsifier/dispersion agents eases the mixing of the other components of the formulation by reducing the viscosity of the initial mixture (M2). The experimental foams that were tried by using lower proportions of either water or isocyanate (MDI), which are not presented in Table 1, suffered either structural collapse due to lack of dissipation of the heat generated by the reaction exotherm or insufficient porosity development. When the proportions of these components are varied, the proportion of the rest of the reagents must be carefully adjusted to obtain well developed, equilibrated foams.

Table 2 shows that all the foams prepared are lightweight, with densities lower than 1 g/cm³. The experimental foams M1 and M2 present a thermal conductivity comparable to that of the SF foam and lower than that determined for the control STD foam. Thus, the new foams without either formaldehyde or blowing agent give a material more apt as thermal insulation and for performance as well as being much more environment-friendly.

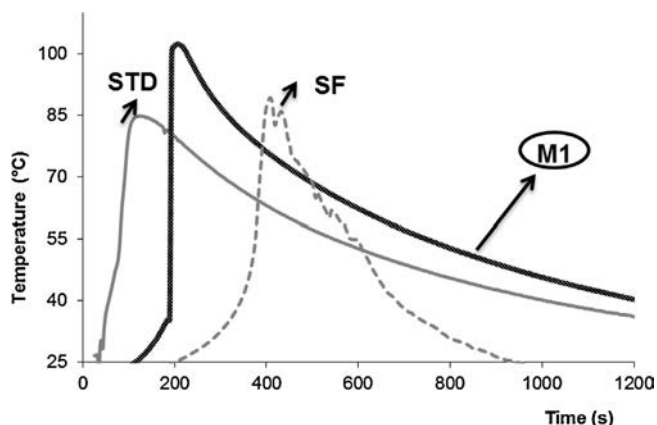

Fig. 2. Variation during foaming of the temperature as a function of time of STD, SF and M1 foams.

Fig. 1 shows the stress–strain curves obtained by compression for the STD, SF and M1 foams. These show that the STD foam is fragile and rigid, while the SF and M1 foams without formaldehyde are more elastic and do not break or crack easily. The elastic modulus of these latter ones is lower. This is to be expected as formaldehyde is known to immobilize early on during cross-linking the tannin oligomers during hardening (Pizzi, 1977, 1978, 1983; Pizzi and Scharfetter, 1978). Equally, the more rapid cross-linking of the network, here due to the presence of the formaldehyde, leads to weaker hardened networks (Lu and Pizzi, 1998). These effects may lead to incomplete cross-linking and a rather brittle hardened network. Thus, the absence of formaldehyde tends to give more flexible chains. Comparing the stress–strain curves in Fig. 1 of the two foams SF and M1, both without formaldehyde, it is evident that the foam M1 is more elastic and more resistant to compression than the SF foam, this being an improvement on all the types of tannin foams reported up to now (Meikleham and Pizzi, 1994; Tondi and Pizzi, 2009; Tondi et al., 2009). The good behavior in compression of the M1 foam is mainly due to the reaction of the small proportion of isocyanate with the $-\text{CH}_2\text{OH}$ groups (Pizzi and Walton, 1992; Pizzi, 1994) of furfuryl alcohol. The small proportion of urethane bridges generated improve the foam mechanical performance, yielding a more elastic material and consequently a better distribution of stress.

Figs. 2 and 4 show the temperature, pressure, expansion rate and dielectric polarisation variation as a function of time during foam preparation. In both Figs. 2 and 4 the variation of these physical parameters during M1 foaming are quite different from what observed for the foams obtained with presence of very volatile organic blowing agents. Fig. 2 shows that the highest temperature reached by the M1 foam (102°C) it is higher than for the STD and SF foams, which for these latter is not higher than 90°C . This difference is due to the inclusion of the isocyanate in the M1 formulation which causes additional exothermal reactions increasing the temperature of the mix and improving the level of cross-linking of the system.

Fig. 3 shows that the peak of pressure reached during foaming by M1 is later, at approximately 205 s and is significantly lower to that of the STD formulation reached at 80 s. The pressure peak occurs at the same time as the peak of temperature for all the three types of foam. This is likely to correspond to the evaporation of the water present in the system. For the STD and SF this is also the case, likely corresponding to the evaporation of water + solvent. The use of formaldehyde and solvent in the STD formulation leads to a marked and abrupt pressure increase which in itself weakens the structure, coupled by lower cross-linking due to early immobilisation of

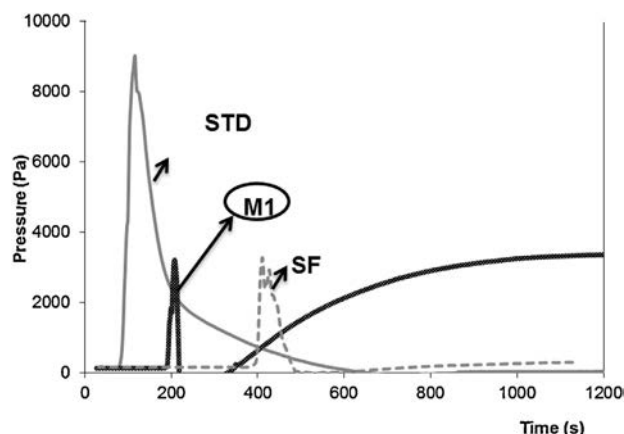

Fig. 3. Variation during foaming of internal pressure as a function of time of STD, SF and M1 foams.

the cured network (Pizzi, 1977, 1978, 1983; Pizzi and Scharfetter, 1978). The pressure increase for SF is only slightly higher to that of M1. However, the M1 formulation without solvent shows a gradual pressure increase starting at 340 s, which corresponds to the cure of the foam as shown by its dielectric polarisation curve in Fig. 4c where hardening starts slightly before than expected. The curves of dielectric polarisation are used to determine resin curing (Sernek and Kamke, 2007). This progressive pressure increase is due to the CO_2 generated by the reaction of the isocyanate with both the $-\text{CH}_2\text{OH}$ groups of furfuryl alcohol and the water present (Frisch et al., 1983; Pizzi and Walton, 1992; Tondi and Pizzi, 2009; Li et al., 2012a,b). As it still occurs during the cross-linking phase it increases the porosity of the foam structure without leading to the collapse or degradation of the foam structure.

Fig. 4a–c shows the STD, SF and M1 foams expansion rate curves, calculated as a function of their height increase, compared with the curves of their dielectric polarisation. The dielectric polarisation of a resin system indicates the curing level of a resin system. Dielectric polarisation is the polarised condition of a dielectric, a polymer chain for example, resulting from an applied electrical field in which these molecules can take a definite orientation. As cross-linking begins and proceeds to the formation of a progressively less mobile, more rigid network the capability of the molecules to be oriented by the applied electrical field progressively decreases. Thus, the dielectric polarisation value decreases markedly when cross-linking begins and continues decreasing to the final immobilisation of the molecules in the network. It can be noticed that for STD and SF foams cross-linking progresses slower than foam growing/blowing, while for the M1 foam both processes occur practically simultaneously. This favors the better mechanical properties observed for the M1 foam and explains also the slightly higher apparent density of this foam (Table 2).

Fig. 5a–c shows the tomography images of the 3 foams tested. From these figures it appears that the STD foam control (Fig. 5a) presents the more regular and compact structure of the three as expected by the presence of an extra cross-linking agent, namely the formaldehyde. The foam SF (Fig. 5b) without formaldehyde but still using a volatile organic blowing agent instead presents a rather open structure with struts relatively spaced out that corresponds to the increased flexibility but accrued weakness and the characteristic stress–strain curve it presents in Fig. 1. Thus, networks produced with blowing agents but with lack of a hardener will show elasticity but relatively lower mechanical resistance. To obtain a suitable foam thus, the elimination of both formaldehyde and blowing agent appears necessary. Thus, the experimental foam M1 without formaldehyde and without volatile organic solvent

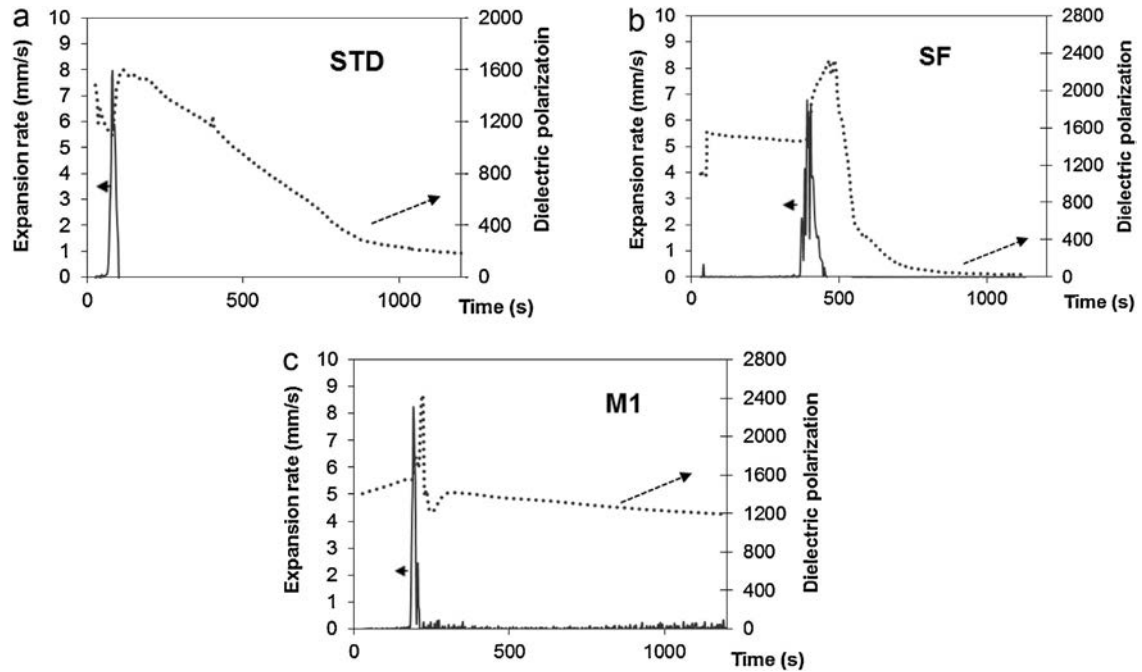

Fig. 4. Profiles of expansion rate and dielectric polarisation as a function of time during foaming of (a) the STD foam, (b) the SF foam and (c) the experimental M1 foam.

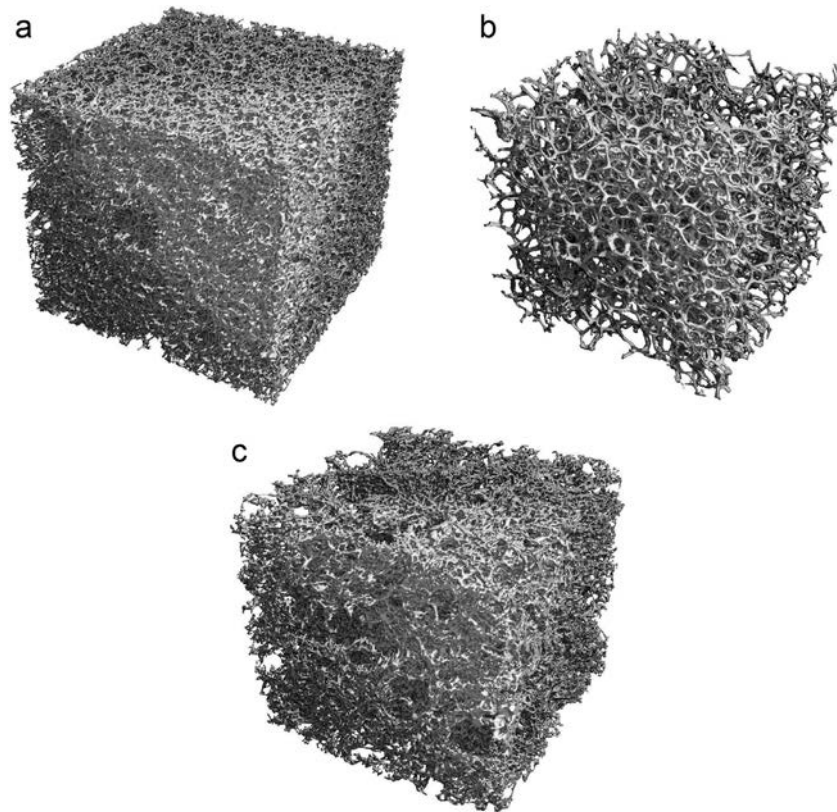

Fig. 5. Foams morphology by tomography. (a) STD foam with formaldehyde and volatile organic solvent, (b) SF foam without formaldehyde and with volatile organic blowing agent, and (c) experimental M1 foam without formaldehyde and without volatile organic blowing agent.

presents a relatively compact structure similar to the STD foam but with a slightly less ordered appearance. Moreover, the ramification of the struts, hence the solid network (Fig. 5c), appears far more hyperbranched than for the STD foam, in line with the different stress–strain behavior of this foams observed in Fig. 1.

4. Conclusions

In conclusion, the composition of foam formulations in which both formaldehyde and very volatile organic blowing agents have been excluded yields foams that are markedly more environment

friendly. These new foams have equally good thermal insulation properties and a better mechanical resistance. Furthermore, they are equally non-flammable, lower cost and obtained from renewable raw materials as the older formulations.

References

- Aguilar, R., Ramirez, J.A., Garrote, G., Vazquez, M., 2002. Kinetic study of the acid hydrolysis of sugar cane bagasse. *J. Food Eng.* 55, 309–318.
- Basso, M.C., Li, X., Giovando, S., Fierro, V., Pizzi, A., Celzard, A., 2011. Green, formaldehyde-free, foams for thermal insulation. *Adv. Mater. Lett.* 2, 378–382.
- Frisch, K.C., Ruma, L.P., Pizzi, A., 1983. Diisocyanate wood adhesives. In: Pizzi, A. (Ed.), *Wood Adhesives Chemistry and Technology*, vol. 1. Marcel Dekker, New York.
- Hildebrand, T., Rueggsegger, P., 1996. A new method for the model-independent assessment of thickness in three-dimensional images. *J. Microsc.* 185, 57–75.
- Lacoste, C., Basso, M.C., Pizzi, A., Laborie, M.-P., Celzard, A., 2013. Pine tannin-based rigid foams: mechanical and thermal properties. *Ind. Crops Prod.* 43, 245–250.
- Li, X., Basso, M.C., Fierro, V., Pizzi, A., Celzard, A., 2012a. Chemical modification of tannin/furanic rigid foams by isocyanates and polyurethanes. *Maderas Cienc. Technol.* 14, 257–265.
- Li, X., Pizzi, A., Cangemi, M., Fierro, V., Celzard, A., 2012b. Flexible natural tannin-based and protein-based biosourced foams. *Ind. Crops Prod.* 37, 389–393.
- Li, X., Srivastava, V.K., Pizzi, A., Celzard, A., Leban, J.M., 2013. Nanotube-reinforced tannin/furanic rigid foams. *Ind. Crops Prod.* 43, 636–639.
- Lu, X., Pizzi, A., 1998. Curing conditions effects on the characteristics of thermosetting adhesives-bonded wood joints – Part 1: substrate influence on TTT and CHT curing diagrams of wood adhesives. *Holz Roh Werkst.* 56, 339–346.
- Meikleham, N.E., Pizzi, A., 1994. Acid- and alkali-catalyzed tannin-based rigid foams. *J. Appl. Polym. Sci.* 53, 1547–1556.
- Nagaraja, B.M., Siva Kumar, V., Shasikala, V., Padmasri, A.H., Sreedhar, B., David Raju, B., Rama Rao, K.S., 2003. A highly efficient Cu/MgO catalyst for vapour phase hydrogenation of furfural to furfuryl alcohol. *Catal. Commun.* 4, 287–293.
- Odgaard, A., 1997. Three-dimensional methods for quantification of cancerous bone architecture. *Bone* 20, 315–328.
- Odgaard, A., Gundersen, H.J., 1993. Quantification of connectivity in cancerous bone, with special emphasis on 3-D reconstructions. *Bone* 14, 173–182.
- Pasch, H., Pizzi, A., Rode, K., 2001. MALDI-TOF mass spectrometry of polyflavonoid tannins. *Polymer* 42, 7531–7539.
- Pizzi, A., 1977. Hot-setting tannin-urea-formaldehyde exterior wood adhesives. *Adhes. Age* 20 (12), 27–32.
- Pizzi, A., 1978. Wattle-based adhesives for exterior grade particleboard. *Forest Products J.* 28 (12), 42–47.
- Pizzi, A., 1983. In: Pizzi, A. (Ed.), *Tannin-based Wood Adhesives in Wood Adhesives Chemistry and Technology*, vol. 1. Marcel Dekker Inc, New York.
- Pizzi, A., 1994. *Advanced Wood Adhesives Technology*. Dekker, New York.
- Pizzi, A., Scharfetter, H., 1978. The chemistry and development of tannin-based wood adhesives for exterior plywood. *J. Appl. Polym. Sci.* 22, 1745–1761.
- Pizzi, A., Tondi, G., Pasch, H., Celzard, A., 2008. Maldi-ToF structure determination of complex thermoset network-polyflavonoid tannin-furanic rigid foams. *J. Appl. Polym. Sci.* 110, 1451–1456.
- Pizzi, A., Walton, T., 1992. Non-emulsifiable, water-based diisocyanate adhesives for exterior plywood, Part 1. *Holzforschung* 46, 541–547.
- Sernek, M., Kamke, F.A., 2007. Application of dielectric analysis for monitoring the cure process of phenol formaldehyde adhesive. *Int. J. Adhes. Adhes.* 27, 567–572.
- Tondi, G., Pizzi, A., 2009. Tannin-based rigid foams: characterization and modification. *Ind. Crops Prod.* 29, 356–363.
- Tondi, G., Zhao, W., Pizzi, A., Fierro, V., Celzard, A., 2009. Tannin-based rigid foams: a survey of chemical and physical properties. *Bioresour. Technol.* 100, 5162–5169.

Conclusions

Conclusions générales

Dans ce mémoire, plusieurs expériences sont rapportées. Elles concernent la caractérisation de la composition des tanins, la chimie de polycondensation des tanins avec l'alcool furfurylique pour faire des mousses sans formaldéhyde, des mousses sans solvant, et des mousses avec catalyse alcaline.

Aussi, nous proposons de faire le bilan des cinq points listés ci-dessous :

1. analyses des tanins, condensés, hydrolysables et synthétiques;
2. mousses aux tanins, sans utilisation de formaldéhyde;
3. mousses aux tanins, sans solvant;
4. mousses aux tanins, rigides ou élastiques;
5. mousses aux tanins, sans acides, mais avec catalyse alcaline.

Analyses des tanins, condensés, hydrolysables et synthétiques

Le travail de caractérisation des tanins avec la spectrométrie MALDI-TOF a été très utile car il a permis de déterminer de manière approfondie la structure et la composition quantitative des différents tanins industriellement disponibles. Cette étude innovante est importante en ce sens qu'il n'y avait pas d'études cohérentes de caractérisation quantitative des substances polyphénoliques contenues dans les tanins synthétiques et végétaux jusqu'à présent.

Nous avons analysé le tanin condensé de quebracho, les tanins hydrolysables du châtaignier, du chêne, du tara, du sumac, de la galle chinoise et de la galle turque et aussi les tanins synthétiques les plus courants : phénoliques, disulfoniques et naphthaléniques.

De plus, nous avons utilisé une nouvelle technique analytique, le MALDI-TOF-CID, pour déterminer le plus précisément possible la structure moléculaire des tanins de tara, de châtaigner et de la galle turque.

Cette caractérisation a permis d'envisager l'utilisation de ces tanins dans des domaines où leur capacité à polymériser est recherchée. Les tanins ont ainsi été utilisés pour formuler des résines phénoliques innovantes notamment celles avec le tanin de châtaignier en remplacement du phénol qui n'avaient encore jamais été étudiées.

Ce travail a donné lieu à six publications.

Mousses aux tanins, sans utilisation de formaldéhyde

Pendant cette thèse, nous avons optimisé des formulations basées sur la réactivité de l'alcool furfurylique avec les tanins pour produire des mousses aux tanins sans formaldéhyde. Ces formulations comportent, à l'exclusion du catalyseur qui est simplement un acide comme l'acide paratoluènesulfonique, 90% de produits d'origine naturelle et renouvelable.

De plus, les caractéristiques mécaniques et les propriétés physiques des mousses produites sont équivalentes voire supérieures à celles des matériaux synthétiques à base de résines phénoliques. C'est par exemple le cas si on les compare aux mousses de polyuréthanes dont les caractéristiques au feu sont très mauvaises. Les propriétés des mousses aux tanins sont modulables dans le sens qu'il est possible d'ajouter des petites quantités d'additifs qui vont modifier par exemple leur hydrophobicité ou au contraire leur capacité à retenir l'eau ou permettre d'avoir des structures à cellules ouvertes ou fermées. Nous pouvons ainsi envisager leur application dans l'agriculture ou le bâtiment.

Les mousses aux tanins sans formaldéhyde que nous définirons de 2^{ème} génération, ont des potentialités de développement très intéressantes au sein des matériaux verts et peu coûteux.

Cette étude innovante a été valorisée par le biais d'une demande de brevet et d'une publication.

Mousses aux tanins, sans solvants

Les solvants sont normalement utilisés pour obtenir l'expansion des mousses polymères. La polymérisation de la résine, à base de tanins dans nos cas, qui se déroule après l'ajout d'un catalyseur, s'accompagne d'un dégagement de chaleur. Cette chaleur fait monter la température dans la masse du polymère si bien que le solvant ajouté à la formulation s'évapore. L'évaporation du solvant et la polymérisation sont donc deux phénomènes qui doivent être synchronisés pour obtenir un matériau expansé.

Néanmoins l'utilisation de solvants pose problème car ils sont dangereux pour l'environnement et pour la santé des opérateurs qui travaillent sur les lignes industrielles de productions des mousses.

Dans le travail de cette thèse, nous avons mis au point des mousses qui se développent grâce à des substances alternatives, comme des sels ou des isocyanates. Celles-ci se décomposent pendant la réaction de polymérisation, sous l'action de la température ou de l'eau du catalyseur, pour donner du dioxyde de carbone CO₂. Le CO₂ permet d'obtenir un matériau expansé beaucoup moins impactant sur l'environnement et sur la santé humaine.

Cette étude innovante a débouché sur une demande de brevet et une publication.

Mousses aux tanins, rigides ou élastiques

Les mousses aux tanins étudiées jusqu'à présent, étaient des matériaux presque toujours rigides et indéformables.

Le travail mené dans cette thèse a permis d'obtenir des matériaux expansés flexibles et élastiques ce qui élargit considérablement leur champ d'applications (par exemple pour l'emballage afin d'absorber les chocs mécaniques).

Cela est rendu possible par le fait que l'on peut exploiter une réaction entre les tanins, un isocyanate et une amine grasse éthoxylée. L'isocyanate permet de faire une liaison entre les différents groupes -OH présents sur les molécules de tanins, et aussi sur la chaîne éthoxylée de l'amine grasse. En plus, du fait de son

caractère basique, l'amine grasse éthoxylée permet de catalyser les réactions de l'isocyanate.

La caractéristique intéressante et nouvelle de ces mousses aux tanins est qu'elles sont flexibles et élastiques et peuvent donc concurrencer les mousses élastiques de polyuréthane, de loin les plus diffusées sur les marchés. En outre et contrairement aux mousses de polyuréthane, ces nouvelles mousses faites avec une grande quantité de produits naturels présentent une certaine résistance au feu et une faible inflammabilité. Par rapport à cette propriété, il faut souligner le problème important d'inflammabilité des mousses de PU. Ces matériaux brûlent très bien car les gouttes de polymère fondu s'enflamment ce qui permet aux incendies de se développer très vite et ça malgré l'ajout de composés pour retarder ou limiter la diffusion des flammes. Notons également que la combustion des mousses PU s'accompagne de la libération de fumées toxiques. Cela permettrait aussi de remplacer avantageusement les mousses de polyuréthanes car les mousses aux tannins développées présentent de bien meilleures caractéristiques de comportement au feu. Les matériaux obtenus brûlent également mais sans la production de gouttes enflammées ce qui constitue un réel avantage de ces mousses d'origine naturelle par rapport à celles de PU.

Une publication sera éventuellement écrite sur ce travail ici.

Mousses aux tanins polymérisables avec un catalyseur acide ou alcalin

Les mousses aux tanins étudiées jusqu'à présent, sont produites par une réaction de polymérisation des tanins avec l'alcool furfurylique, catalysée par un acide, normalement un acide organique comme l'acide paratoluènesulfonique ou l'acide phénolsulfonique. En conséquence, les mousses obtenues ont toutes un caractère acide qui les rend incompatibles avec certains matériaux sensibles comme par exemple le bois, l'acier ou le fer.

Sur le marché des matériaux expansés, le même problème se pose avec les mousses phénoliques qui sont polymérisables uniquement par une catalyse

acide. Aussi notre objectif était de produire des mousses aux tanins par voie alcaline.

Compte tenu que les tanins condensés ont la capacité de polymériser en milieu alcalin, nous avons utilisé cette propriété pour élaborer un matériau expansé dont les applications pourraient être élargies à plusieurs domaines.

Cette composition est totalement libre de formaldéhyde. Le caractère innovant dans cet étude repose sur l'utilisation possible d'un catalyseur alcalin ou acide.

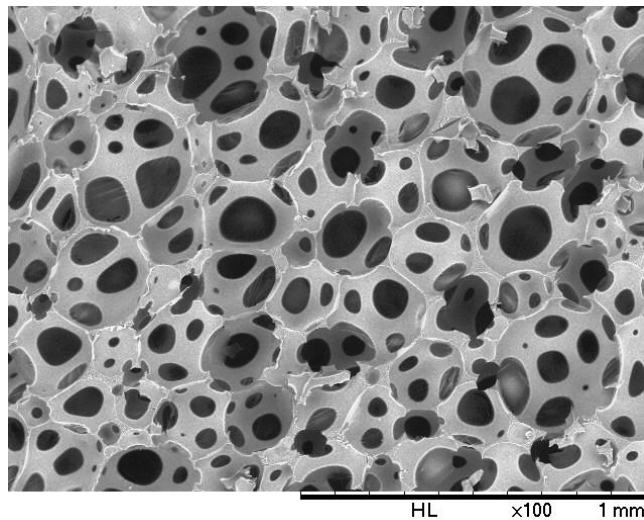

La Figure correspond à une image au microscope électronique à balayage (MEB) d'un matériau expansé obtenu par catalyse alcaline (grossissement 100x). On peut noter une structure bien régulière et alvéolaire.

Une publication sera éventuellement écrite sur ce travail ici.

Recommandations

L'étude commencée dans ce travail de thèse doit sans conteste être continuée du fait des retours positifs de l'industrie des tanins, de l'industrie chimique, et notamment des matériaux expansés pour diverses applications (transport des fleurs et hydroponique, agriculture, bâtiment, architecture...).

Pour produire des produits vraiment innovants et durables sur le marché, on a besoin de comprendre le rôle des différents additifs et de connaître leurs caractéristiques physicochimiques. Chaque industrie a besoin de savoir les spécifications demandées pour leur propre secteur d'application.

Par exemple, l'industrie des mousses pour l'agriculture a besoin d'avoir des informations sur la biodégradabilité car en fin de vie, ces nouveaux matériaux expansés doivent être éliminés le plus simplement et le plus proprement possible, et de préférence ne pas être traités comme des déchets spéciaux (comme c'est le cas des mousses phénoliques aujourd'hui ; cela constituerait d'ailleurs un grand avantage par rapport à ces dernières).

Par ailleurs, l'industrie des bâtiments doit connaître le pouvoir d'isolation thermique ou acoustique ou la capacité de résister au feu des mousses utilisées, car ces caractéristiques seront déterminantes pour envisager le remplacement des panneaux phénoliques ou de polyuréthane expansés mis en œuvre actuellement.

Les évolutions auxquelles on doit s'attendre portent surtout sur les tanins, en particulier sur leur origine car les tanins peuvent être extraits de plusieurs sources. Par exemple, les tanins extraits des écorces dans l'industrie du bois, pourraient se trouver valorisés. La France dispose de très grandes quantités d'écorces de pin maritime, provenant de l'industrie des panneaux en bois, qui ne sont valorisées que de façon énergétique (elles sont brûlées). Les pays scandinaves où l'industrie du bois est particulièrement développée disposent également de quantités impressionnantes d'écorces qui contiennent environ 15-20% de tanins par rapport à leur poids sec. Donc la quantité des tanins à disposition pour l'industrie est vraiment intéressante pour permettre la production de produits dérivés.

Par ailleurs, il est possible de modifier chimiquement les tanins avant de les utiliser avec les résines dans les recettes des mousses. Par exemple, les tanins

peuvent être rendus moins polaires et donc moins hydrophiles via des réactions d'estérification par addition d'un anhydride (acétique ou autre). Les tanins peuvent aussi être rendus plus polaires et donc plus hydrophiles via des réactions de sulfitation ou d'éthoxylation.

Les mousses étudiées dans cette thèse n'ont été élaborées qu'avec des tanins naturels et avec des additifs standards. Il serait souhaitable de continuer les études engagées pour tous les domaines pris en considération : mousses sans formaldéhyde, mousses élastiques, mousses sans solvants, mousses alcalines. Pour chacun de ces types, il faudrait trouver une formulation idéale qui satisfasse à la fois les producteurs de tanins, de résines et/ou de matériaux expansés.

Ainsi, l'industrie des tanins, au sens large du terme, pourrait vraiment contribuer largement au développement de ces matériaux dans un proche avenir.

Les programmes futurs de développement de ce projet sont cohérents avec les recherches actuelles sur les matériaux biosourcés et privilégiant une approche basée sur une chimie verte et écosoutenable. Aussi pour cette raison, le développement de ces matériaux doit être prolongé car il s'inscrit parfaitement dans l'évolution générale de la chimie des matériaux en Europe et dans le monde.

Perspectives

Différentes perspectives de recherches et d'applications industrielles ont été ouvertes pendant ce travail de thèse.

Il est maintenant nécessaire d'en dresser un bilan pour savoir quels peuvent être les développements dans un futur proche et à plus long terme.

Du point de vue de la synthèse des résines à base de tanins, des améliorations peuvent être apportées pour changer par exemple les caractéristiques de réactivité, de viscosité des résines et même d'hydrophilie/hydrophobicité des matériaux expansés.

Du point de vue de la caractérisation, des tests d'absorption acoustique ainsi que des mesures plus précises de conductivité thermique, ou de résistance au feu, pourraient être envisagés de façon à caractériser encore plus complètement les nouveaux matériaux. Ces deux caractéristiques représentent actuellement la clé pour positionner de façon compétitive ces matériaux sur le marché des mousses rigides et élastiques.

De plus, pour permettre un développement industriel durable et stable dans le futur, il est indispensable d'améliorer la qualité des mousses de tanin produites dans des moules de grandes dimensions. En effet, la distribution de la porosité dans de telles structures doit rester homogène comme celle qui a pu être obtenue lors des développements en laboratoire sur des structures plus petites.

Enfin on peut envisager de faciliter la production des mousses sur une ligne de production industrielle batch ou continue par l'étude puis l'intégration d'un système d'agitation mécanique, efficace et automatisé ou d'un système mixer statique continu.

Références

Allcock, H.R. et Lampe, F.W. : Contemporary polymer chemistry. Prentice-Hall, New Jersey, 1990.

Arisetty, S. , Prasad, A.K., Advani S.K. : Metal foams as flow field and gas diffusion layer in direct methanol fuel cells. J.Power.Sources, 165, 49-57, 2007.

Ballerini, A. , Despres, A., Pizzi, A. : Non-toxic, zero emission tanin-glyoxal adhesives for wood panels. Holz Roh Werkst., 63, 477-478, 2005

Becker, G.H.R : Protection of timber, an introduction into some problems. Biodeterioration Symp.1968.

Boudart, M, Leclercq, L.E. : Carburised or nitrided molybdenum oxy-carbide catalyst – of high surface area e.g. for hydrocarbon product of synthesis gas and coal liquefaction. US patent US4271041-A, 1981.

Cadahía, E. , Conde, E., García-Vallejo, M.C., De Simón, B.F. : Gel permeation chromatographic study of the molecular weight distribution of tanins in the wood, bark and leaves of Eucalytus spp. Chromatographia, Vol. 42, No 1/2, 95-100, 1996.

Calleri, L.: Le fabbriche italiane di estratti di castagno. Silva, Cuneo, 1989

Celzard, A., Mareche, J.F., Furdin, G. : Modelling of exfoliated graphite. Green Chem., 7, 784-792, 2005.

Chen, C., Kennel, E.B., Stiller,A.H., Stansberry, P.G., Zondlo, J.W. : Carbon foam derived from various precursors. Carbon, 44, 1535-1543, 2006.

Chen, X., Li, H., Luo,H.S., Qiaoet, M. : Liquid phase hydrogenation of furfural to furfuryl alcohol over Mo-doped Co-B amorphous alloy catalysts. Applied Catalysis, 233 (1-2),13-20, 2002

Cheyrier, V., Souquet, J.M.; Le Roux, E., Guyot, S.; Rigaud, J. : Size separation of condensed tanins by normal-phase-high-performance liquid chromatography. Methods in enzymology, 299, 178-184, 1999.

Choura, M., Belgacem, N.M., Gandini, A. : Acid catalysed polycondensation of Furfuryl alcohol : Mechanism of Chromophore formation and crosslinking. Macromolecules. 29, 3839-3850, 1996.

Donkin, M.J. et Pearce, J. : Tanin analysis by near infrared spectroscopy. J. Soc. Leather Technol. Chem., 79, 8-11, 1995.

Dresselhaus, M.S. : Carbon Nanotubes. Carbon, 33 (7), 871-872, 1995.

Drewes, E. et Roux, D.G. : Condensed tanins XV – Interrelations of flavonoid components in wattle-bark extract. *Biochem. J.*, 87(1), 167-172, 1963.

Dweib, M.A., Hu, B., O'Donnell, A., Shenton, H.W., Wool, R.P. : All natural composite sandwich beams for structural applications. *Comp. struct.*, 63, 147-157, 2004.

Findley, W.P.K. : Preservative substances. *Martinus-Junk Publ.*, 60-74, 1985.

Foo L.Y. et Hemingway, R.W. : Condensed tanins : Reactions of model compounds with furfuryl alcohol and furfuraldehyde. *J.Wood Chem.Techn.*, 5(1), 135-158 , 1985.

Gallego,N. et Klett, J.W. : Carbon foams for thermal management. *Carbon*, 41, 1461-1466, 2003.

Gandini, A. et Belgacem, N.M. :Furans in polymer chemistry.*Progr. Polym.Sci.*, 22, 1203-1379, 1997.

Garcia, R. Pizzi, A. et Merlin, A. : Ionic polycondensation effects on radical autocondensation of polyflavonoid tanins : an ESR study. *J. Appl. Polym. Sci*, vol 65, 2623–2633, 1997.

Garcia, R. et Pizzi, A. (1) : Polycondensation and autocondensation networks in polyflavonoid tanins. I. Final networks. *J. Appl. Polym. Sci*, vol 70, 1083-1091, 1998.

Garcia, R. et Pizzi, A. (2) : Polycondensation and autocondensation networks in polyflavonoid tanins. II. Polycondensation versus autocondensation. *J. Appl. Polym. Sci*, vol 70, 1093-1109, 1998.

Haslam, E. : Plant polyphenols: vegetable tanins revisited. Cambridge University Press, DEFRA, 1989

Hillis, W.E. et Urbach, G. : The reaction of catechin with polyphenols with formaldehyde *J.Appl.Chem.*,vol.9, 474 et 665, 1959

Hoadley, R.B : Understanding Wood.*Taunton.com*.1980

Hofmann, K. et Glasser, W.G. : Cure monitoring of an epoxy-amine system by dynamic mechanical thermal analysis (DMTA). *Thermochim. Acta*, 166, 169-184, 1990.

Iley, M., Marsh, H., Rodriguez-Reinoso, F. : The adsorptive properties of carbonised olive stones. *Carbon*, 11(6), 633-636, 1973.

Ji, N., Zhang, T., Zheng, M., Wang, A., Wang, H., Wang, X., Chen, J.G. : Direct Catalytic Conversion of Cellulose into Ethylene Glycol Using Nickel-Promoted Tungsten Carbide Catalysts. *Angew. Chem. Int.*, 47, 8510-8513, 2008.

Jurd, L. : The hydrolysable tanins. In : wood extractives and their significance to the pulp and paper industries. Hillis, W.E. Ed., Academic press, New York, London, 229-260, 1962.

Kamdem, D.P. , Pizzi, A., Jermannaud, A. : Durability of heat-treated wood. Holz Roh Werkst, 60(1), 1-6,2002.

Kirby, K.S., Knowles, E., White, T. : Tanins. V. The fractionation of quebracho extract. J. Soc. Leather Technol. Chem., 37, 283-294, 1953.

Kirkpatrick, J.W. et Barnes, H.M. : Copper naphthenate treatments for engineered wood composite panels. Biores.Techn., 97(15), 1959-1963, 2006.

Kratschmer, W., Lamb, L.D., Fostiropoulos, K., Huffman, D.R. :Solid C60 A new form of carbon. Nature. 347 (6291), 354-358, 1990.

Kulik, N., Goi, A., Trapido, M., Tuhkanen, T. : Degradation of polycyclic aromatic hydrocarbons by combined chemical pre-oxidation and bioremediation in creosote contaminated soil. J.Environ.Manag., 78(4), 382-391, 2006.

Kulvik, E. : Chestnut wood tanin extract in plywood adhesives. Adhesives Age, 19(3), 19-21, 1976.

Kulvik, E. : Chestnut wood tanin extract as a cure accelerator for phenol-formaldehyde wood adhesives. Adhesives Age, 20(3), 33-34, 1977.

Lamar, R.T., Davis, M.W., Dietrich, D.M., Glaser, J.A. : Treatment of a pentachlorophenoland creosote-contaminated soil using the lignin-degrading fungus *Phanerochaete sordida*: A field demonstration. Soil Biol. Biochem.,26(12), 1603-1611, 1994.

Larsson Brelid, P., Simonson, R., Bergman, O., Nilsson, T. : Resistance of acetylated wood to biological degradation. Holz Roh Werkst, 58(5),331-337.2000

Lee, K.S., Park, J.Y., Kim, W.J., Hong, G.W. : Effect of microstructure of SiC layer on the indentation properties of silicon carbide-graphite system fabricated by LPCVD method. J. Mat. Sci Let., 20, 1229-1231, 2001.

Legendre, A. : Le materiau carbone- Des ceramique moires aux fibres de carbone. Eyrolles Ed. 1992.

Masson, E., (1), Merlin, A., Pizzi, A.: Comparative kinetics of induced radical autocondensation of polyflavonoid tanins. I. Modified and nonmodified tanins. J. Appl. Polym. Sci, 60, 263-269, 1996.

Masson, E., (2), Merlin, A., Pizzi, A.: Comparative kinetics of induced radical autocondensation of polyflavonoid tanins. III. Micellar reactions vs. Cellulose surface catalysis. J. Appl. Polym. Sci, 60, 1655-1664, 1996.

Masson, E., (3), Merlin, A., Pizzi, A.:Comparative kinetics of induced radical autocondensation of polyflavonoid tanins. II. Flavonoid units effects. J. Appl. Polym. Sci, 64, 243-265, 1997.

McLean, H. et Gardner, J. : Bark extracts in adhesives. J.A.F. Pulp Paper Mag. Can.53, 9, 111-114,1952.

Meikleham, N., Pizzi, A., Stephanou, A. : Induced accelerated autocondensation of polyflavonoid tanins for phenolic polycondensates : ¹³C-NMR, ²⁹SI-NMR, X-Ray, et polarimetry studies and mechanism. J.Appl. Polym. Sci.,54, 1827-1845, 1994.

Merlin, A. et Pizzi, A. : An ESR study of the silica-induced autocondensation of polyflavonoid tanins. J. Appl. Polym. Sci, 59, 945-952, 1996.

Muralidharan, D. : Spectrophotometric analysis of catechins and condensed tanins using Ehrlich's reagent. J. Soc. Leather Technol. Chem., 81, 231-233, 1997.

Nagaraja, B.M., Siva Kumar, V., Shasikala, V., Padmasri, A.H., Sreedhar, B., David Raju, B., Rama Rao, K. S. : A highly efficient Cu/MgO catalyst for vapour phase hydrogenation of furfural to furfuryl alcohol. Catalyst communication, 4(6),287-293, 2003

Nakagawa, K. et Sugita, M. : Spectroscopic characterisation and molecular weight of vegetable tanins. J. Soc. Leather Technol. Chem., 83, 261-264, 1999.

Noferi, M., Masson, E., Merlin, A., Pizzi, A., Deglise, X. : Antioxidant characteristics of hydrolysable and polyflavonoid tanins : an ESR kinetics study. J. Appl. Polym. Sci., Vol. 63, 475-482, 1997.

Osman, Z. et Pizzi, A. : Comparison of gelling reaction effectiveness of procyanidin tanins for wood adhesives. Holz Roh Werkst. 200260 (5), 328, 2002.

Pasch, H., Pizzi, A., Rode, K. : MALDI-TOF mass spectrometry of polyflavonoid tanins. Polymer, vol.42, 18,7531-7539, 2001

Pessoa, A. , Mancilha, I.M., Sato, s. : Acid Hydrolysis of Hemicellulose from Sugarcane Bagasse. Braz. J. Chem. Engin., 14(3), 1997

Pizzi, A. : Chemistry and technology of cold and thermosetting wattle tanin based wood adhesives. Ph.D. Thesis, University of the Orange Free State, Orange, South Africa, 1977.

Pizzi, A. : The chemistry and development of tanin-based adhesives for exterior plywood J.Polym.Sci.,22(8), 2397-2399, 1978.

Pizzi, A. : Tanin-based Adhesives. J. Macromol. Sci.-Rev. Macromol. Chem. C 18, 247-315, 1980.

Pizzi, A. : Advanced wood technology. Marcel Dekker, New York, 1994.

Pizzi, A. et Baecker, A. : A New Boron Fixation Mechanism for Environment Friendly Wood Preservatives. Holzforschung, 50, 507-510. 1996

Pizzi, A. et Conradie, W.E. : A Chemical Balance/Microdistribution Theory- New CCA Formulations for Soft-rot Control ?.Wood Sci. Techn., 20, 71-81, 1986

Pizzi, A. et Meikleham, N. : Induced accelerated autocondensation of polyflavonoid tanins for phenolic polycondensates. III : CP-MAS ¹³C-NMR of different tanins and models. J. Appl. Polym. Sci, 55, 1265-1269, 1995.

Pizzi, A. et Roux D.G. : Resorcinol/wattle flavonoids condensates for cold-setting adhesives J.Appl.Polym.Sci., 22 (8), 1945-54, 1978

Pizzi, A. et Scharfetter H.O. : The chemistry and development of tanin-based adhesives for exterior plywood. J.Appl.Polym.Sci., 22 (6), 1745-6, 1978

Pizzi, A. et Stephanou, A. (1) : A ¹³C NMR study of polyflavonoid tanning adhesive intermediates. I : non colloidal performance rearrangements. J. Appl. Polym. Sci, 51, 2109-2124, 1994.

Pizzi, A. et Stephanou, A. (2) : A ¹³C NMR study of polyflavonoid tanning adhesive intermediates. II : colloidal state reactions. J. Appl. Polym. Sci, 51, 2125-2130, 1994.

Pizzi, A., (1), Meikleham, N., Stephanou, A.: Induced accelerated autocondensation of polyflavonoid tanins for phenolic polycondensates. II : cellulose effect et application. J. Appl. Polym. Sci., 55, 929-933, 1995.

Pizzi, A., (2), Meikleham, N., Dombo, B., Roll, W.: Autocondensation-based , zero-emission, tanin adhesives for particleboard. Holz Roh Werkstoff, 53, 201-204, 1995

Plomley, K.F. : Tanin-formaldehyde adhesives Australia, Commonwealth Sci. Ind. Res. Organ. Div. For. Prod. Techn. Paper, vol.46, 16-19, 1966.

Porter, L.J. : The flavonoids. J.B. Harborne, Ed., Chapman and Hall, London, 1988.

Radivojevic, S. et Cooper, P.A. : Effects of CCA-C preservative retention and wood species on fixation and leaching of Cr, Cu, and As. Wood Fiber Sci., 39(4), 591-602, 2007.

Riesen, R. et Sommeraurer, H. : Curing of reaction molding resins studied by thermoanalytical methods.Amer. Lab., 15, 30-32, 1983.

Robbins, C.T., Hanley, T.A., Hagerman, E.A., Hjeljord, O., Baker, D.L., Schwartz, C.C., Mautz, W.W. : Role of tanins in defending plants against ruminants: reduction in protein availability, Ecology, vol.68(1), 98-107, 1987

Rode , A.V., Gamaly, E.G., Christy, A.G., Fitz Gerald, J.G., Hyde, S.T., Elliman, R.G., Luther-Davies, B., Veinger, A.I., Androulakis, J., Giapintzakis, J. : Unconventional magnetism in all-carbon nanofoam. Physical Rev.B – Cond. Mat. & Mat. Phys., 70(5), 54407, 2004.

Rossouw, D. du T : Reaction kinetics of phenols and tanin with aldehydes. M.Sc.Thesis, University of South Africa, Pretoria, South Africa, 1979.

Rossouw, D. Du T., Pizzi, A., McGillivray, G. : The kinetics of condensation of phenolic polyflavonoid tanins with aldehydes..J.Polym.Sci.Polym.Chem.Ed.,vol. 18, 3323-3343, 1980.

Roux, D.G. : Recent advances in the chemistry and chemical utilization of the natural condensed tanins. *Phytochemistry*, 11(4), 1219-1230, 1972.

Roux, D.G. et Paulus, E. : Condensed tanins VIII : The isolation and distribution of interrelated heartwood components of *Schinopsis* species. *Biochem. J.*, 78, pp 758-759 ; 80 ; 62-63, 1961.

Roux, D.G., Ferreira, D, Hundt, H.K.L., Malan, E. : Structure stereochemistry and reactivity of natural condensed tanins as basis for their extended industrial application. *Appl. Polym. Symp. 28 (Proc. Cellul. Conf., 8th, 1974, Vol. 1)*, 335-353, 1975.

Roux, D.G., Ferreira, D., Botha, J.J., Garbutt, D.C.F. : Heartwood extracts of the black wattle (*Acacia mearnsii*) as a possible source of resorcinol.*Appl. Polym. Symp. 28*, 1365-1376, 1976.

Saayman, H.M. : *Res.Bull., Leather Industries Research Institute 466, Grahamstown, South Africa, 1971.*

Scalbert, A., Cahill, D., Dirol, D., Navarrete, M.A., De Troya, M.T., Van Leemput, M. : A Tanin/Copper preservation treatment for wood. *Holzforschung*, 52(2), 133-138, 1998.

Scharfetter, H., Pizzi, A., Rossouw, D. Du T. : IUFRO Conference on Wood Gluing, Merida, Venezuela, 1977

Sealy-Fisher, V.J. et Pizzi, A. : Increased pine tanins extraction and wood adhesives development by phlobaphenes minimization.*Holz Roh Werkst.* 50(5), 212-220, 1992.

Seymour, R.B. et Carraher, C.E. : *Polymer chemistry, an introduction.* Dekker, New Yourk, 1992.

Shim, V.P.W. et Yap, K.Y. : Static and impact crushing of layered foam-plate systems. *Int. Mech .Sci.* 39 (1), 69-86, 1997.

Sproull,R.D., Bienkowski, P.R., Tsao, G.T. : Production of furfural from corn stover hemicellulose. *Biotechn. Bioengeen. Symp.* 15, 561-577, 1986.

Tarascon, J.M. et Armand, M.: Issues and challenges facing rechargeable lithium batteries. *Nature*, 414, 359-367, 2001.

Thevenon, M.F.,(1), Pizzi, A., Haluk, J.P.: Protein borates as non-toxic, long-term, widespectrum, ground-contact wood preservatives. *Holzforschung* 52(3),241-248, 1998.

Thevenon, M.F.,(2), Pizzi, A., Haluk, J.P.: One-step tanin fixation of non-toxic protein borates wood preservatives. *Holz Roh Werkst.* 56 (1), 90, 1998.

Thompson, D. et Pizzi, A. : Simple ¹³C-NMR methods for quantitative determinations of polyflavonoid tanin characteristics. *J. Appl. Polym. Sci*, 55, 107-112, 1995.

Tondi, G., Fierro, V., Pizzi, A., Celzard, A. : Tanin-based carbon foams. *Carbon*, 47, 1470-1492, 2009.

Weaire, D et Phelan, R. : The Physics of Foam. *J.Phys.Cond.mat.*, 8, 9519-9524, 1996

Yamaguchi,H. et Okuda, K.I. : Chemically modified tanin and tanin-copper complexes as wood preservatives. *Holzforschung*, 52 (6), 596-602, 1998

Yin, S., Deglise, X., Masson, D. : . Thermomechanical analysis of wood / aminoplastic adhesives joints cross-linking - UF, MUF, PMUF. *Holzforschung*, 49, 575-580, 1995.

Zalacain, A., Carmona, M., Lorenzo, C., Blazquez, I., Alonso, G.L. : Antiradical efficiency of different vegetable tanin extracts. *J. Amer. Leather Chem. Ass.*, 97, 137-142, 2002.

Zucker, W.V. : Tanins : Does the structure determine function ? An ecological perspective. *The American Naturalist*, 121 (3), 335-365, 1983.